

User's Guide

Keysight DAQ970A/DAQ973A Data Acquisition System



Notices	6
Copyright Notice	6
Manual Part Number	6
Edition	6
Published by	6
Software Revision	6
Warranty	7
Technology Licenses	7
Restricted Rights Legend	7
Waste Electrical and Electronic Equipment (WEEE)	7
Declarations of Conformity	8
Safety and Regulatory Information	9
Safety Considerations	9
Safety Symbol and Regulatory Markings	10
South Korean Class A EMC Declaration	11
Safety and EMC Requirements	12
Environmental Conditions and General Characteristics	12
1 Introduction to the Instrument	13
Instrument at a Glance	14
Front Panel at a Glance	15
Instrument Annunciators	16
Rear Panel at a Glance	17
Plug-In Modules at a Glance	18
Dimension Diagram	19
Remote Interface Configuration	20
Keysight IO Libraries Suite	20
GPIB Settings (DAQ973A only)	20
LAN Settings	21
LAN Services	27
Set to Defaults	27
LAN Reset	27
Web Interface	28
More about IP Addresses and Dot Notation	28
USB Settings	29
Technical Connection Details	30
LAN Configuration Procedure	31
Firmware Update	33
Contacting Keysight Technologies	34
2 Quick Start	35
Prepare Instrument for Use	36
Module Wiring Connection and Installation	37
Installing the Module	37
Uninstalling the Module	39
Connect Power and I/O Cables	40
To turn on the instrument	40
Power-on self test	40
To turn off the instrument	40
Use the Built-In Help System	41
View the list of help topics	41
View the help information for a front panel key	42

View the instrument information	42
Adjust the Carrying Handle	43
Rack Mounting the Instrument	44
Keysight BenchVue Data Acquisition (DAQ) Software	46
BenchVue Data Acquisition (DAQ) Software Licensing	46
3 Features and Functions	47
System Overview	48
Data Acquisition System Overview	48
Signal Routing and Switching	52
Measurement Input	54
The Multifunction Module	58
Control Output	59
Front Panel Menu References	62
[Scan/Start] Key	64
[Monitor] Menu	65
Number	66
Bar Meter	67
Trend Chart	68
Histogram	69
[Home] Menu	71
Data acquisition mode	71
Strain offset	72
Alarm output	74
Help topics	74
User settings	75
[View] Menu	78
[View] Menu in Scan mode	78
[View] Menu in DMM Digitize or Digitizer mode	83
Power Analysis	91
[View] Menu Status	94
[Channel] Menu	95
Multiplexer modules: Measurements	95
Multiplexer modules: Switch mode	131
DAQM907A - Multifunction Module	134
DAQM909A - 4 Channel 24-Bit Digitizer Module	142
Computed Channel	147
Scanning with External Instruments	152
Channel Labeling	153
[Interval] Menu	154
[Interval] menu in Scan mode	154
[Interval] menu in DMM Digitize mode	157
[Interval] menu in Digitizer mode.	160
[Math] Menu	164
mX+b Scaling	164
% Scaling	165
dBm Scaling	165
dB Scaling	166
[Copy] Menu	167
Copy/paste from a single channel to a single channel (one-to-one)	167
Copy/paste from a single channel to multiple channels (one-to-many)	168
Copy/paste from multiple channels to multiple channels (many-to-many)	169

[Alarm] Menu	170
Configuring alarms limits on multiplexer modules	170
Configuring alarm limits with the multifunction module	171
Alarm limit indications	172
[Utility] Menu	174
Self Test	174
Autocal	174
Calibrate	175
Security	176
Admin	176
[Module] Menu	177
Scan List	177
Card Reset	178
Module Label	178
Relay Cycle	179
[Save Recall] Menu	180
Manage Files	180
Save	181
Recall	182
Set to Defaults	182
Log to USB	183
Save to USB	186
Web Interface	188
Control Instrument page	189
Configure LAN page	189
Help page	190
Module Overview	191
DAQM900A 20-Channel FET Multiplexer Module	192
DAQM901A 20-Channel Armature Multiplexer Module	193
DAQM902A 16-Channel Reed Multiplexer Module	194
DAQM903A 20-Channel Actuator/General-Purpose Switch Module	195
DAQM904A 4x8 Two-Wire Matrix Switch	196
DAQM905A Dual 1:4 RF Multiplexer (50 Ω) Module	197
DAQM907A Multifunction Module	198
DAQM908A 40-channel Single-ended Multiplexer	200
DAQM909A 4-Channel 24-Bit Digitizer Module	201
4 Measurement Tutorials	203
System Cabling and Connections	204
Cable specifications	204
Grounding techniques	206
Shielding techniques	207
Separation of high-level and low-level signals	207
Source of system cabling errors	207
Measurement Fundamentals	211
The internal DMM	211
Temperature measurements	212
DC voltage measurements	220
AC voltage measurements	224
Current measurements	230
Resistance measurement	232
Strain gage measurements	235

Frequency and period measurements	238
Capacitance measurements	240
Digitizing measurements	241
Level triggering	243
Low-Level Signal Multiplexing and Switching	244
One-wire (single-ended) multiplexers	244
Two-wire multiplexers	245
Four-wire multiplexers	245
Signal routing and multiplexing	246
Sources of error in multiplexing and switching	246
Actuators and General-Purpose Switching	248
Matrix Switching	251
RF Signal Multiplexing	253
Multifunction Module	255
Digital Input	255
Digital Output	256
Using external pull-up	257
Driving external switches	257
Totalizer	258
Totalizer errors	259
Analog Output (DAC)	259
Relay Life and Preventive Maintenance	261

Notices

Copyright Notice

© Keysight Technologies, 2019–2020

No part of this manual may be reproduced in any form or by any means (including electronic storage and retrieval or translation into a foreign language) without prior agreement and written consent from Keysight Technologies as governed by United States and international copyright laws.

Manual Part Number

DAQ97-90000

Edition

Edition 3, June 3, 2020

Published by

Keysight Technologies
Bayan Lepas Free Industrial Zone
11900 Bayan Lepas, Penang
Malaysia

Software Revision

Periodically, Keysight releases software updates to fix known defects and incorporate product enhancements. To search for software updates and the latest documentation for your product, go to the product page at:

- www.keysight.com/find/DAQ970A
- www.keysight.com/find/DAQ973A

A portion of the software in this product is licensed under terms of the General Public License Version 2 (GPLv2). The text of the license and source code can be found at www.keysight.com/find/GPLV2.

This product uses Microsoft Windows CE. Keysight highly recommends that all Windows-based computers connected to Windows CE instruments use current anti-virus software. For more information, go to the respective product page at:

- www.keysight.com/find/DAQ970A
- www.keysight.com/find/DAQ973A

Warranty

THE MATERIAL CONTAINED IN THIS DOCUMENT IS PROVIDED "AS IS", AND IS SUBJECT TO BEING CHANGED, WITHOUT NOTICE, IN FUTURE EDITIONS. FURTHER, TO THE MAXIMUM EXTENT PERMITTED BY APPLICABLE LAW, KEYSIGHT DISCLAIMS ALL WARRANTIES, EITHER EXPRESS OR IMPLIED, WITH REGARD TO THIS MANUAL AND ANY INFORMATION CONTAINED HEREIN, INCLUDING BUT NOT LIMITED TO THE IMPLIED WARRANTIES OF MERCHANTABILITY AND FITNESS FOR A PARTICULAR PURPOSE. KEYSIGHT SHALL NOT BE LIABLE FOR ERRORS OR FOR INCIDENTAL OR CONSEQUENTIAL DAMAGES IN CONNECTION WITH THE FURNISHING, USE, OR PERFORMANCE OF THIS DOCUMENT OR OF ANY INFORMATION CONTAINED HEREIN. SHOULD KEYSIGHT AND THE USER HAVE A SEPARATE WRITTEN AGREEMENT WITH WARRANTY TERMS COVERING THE MATERIAL IN THIS DOCUMENT THAT CONFLICT WITH THESE TERMS, THE WARRANTY TERMS IN THE SEPARATE AGREEMENT SHALL CONTROL.

Technology Licenses

The hardware and/or software described in this document are furnished under a license and may be used or copied only in accordance with the terms of such license.

Restricted Rights Legend

If software is for use in the performance of a U.S. Government prime contract or subcontract, Software is delivered and licensed as "Commercial computer software" as defined in DFAR 252.227-7014 (June 1995), or as a "commercial item" as defined in FAR 2.101(a) or as "Restricted computer software" as defined in FAR 52.227-19 (June 1987) or any equivalent agency regulation or contract clause. Use, duplication or disclosure of Software is subject to Keysight Technologies' standard commercial license terms, and non-DOD Departments and Agencies of the U.S. Government will receive no greater than Restricted Rights as defined in FAR 52.227-19(c) (1-2) (June 1987). U.S. Government users will receive no greater than Limited Rights as defined in FAR 52.227-14 (June 1987) or DFAR 252.227-7015 (b)(2) (November 1995), as applicable in any technical data.

Waste Electrical and Electronic Equipment (WEEE)

This product complies with the European WEEE directive marketing requirement. The affixed product label (see below) indicates that you must not discard this electrical/electronic product in domestic household waste.

Product Category: With reference to the equipment types in the European WEEE directive Annex 1, this product is classified as "Monitoring and Control instrumentation" product. Do not dispose in domestic household waste.

To return unwanted products, contact your local Keysight office, or see <http://about.keysight.com/en/companyinfo/environment/takeback.shtml> for more information.



Declarations of Conformity

Declarations of Conformity for this product and for other Keysight products may be downloaded from the Web. Go to <https://regulations.about.keysight.com/DoC/default.htm>, you can then search by product model number to find the latest Declaration of Conformity.

Safety and Regulatory Information

Safety Considerations

The following general safety precautions must be observed during all phases of operation, service, and repair of this instrument. Failure to comply with these precautions or with specific warnings elsewhere in this manual violates safety standards of design, manufacture, intended use of the instrument, and could result in electrical shock or injury. Keysight Technologies assumes no liability for the customer's failure to comply with these requirements.

WARNING

BEFORE APPLYING POWER

Verify that all safety precautions are taken. Make all connections to the unit before applying power.

GROUND THE INSTRUMENT

This product is provided with protective earth terminals. To minimize shock hazard, the instrument must be connected to the ac power mains through a grounded power cable, with the ground wire family connected to an electrical ground (safety ground) at the protective (grounding) conductor. Disconnection of the protective earth terminal will cause a potential shock hazard that could result in personal injury.

BEFORE POWER ON AND OFF

Before powering on the instrument, make sure all signal sources connected to modules are turned off. Turn on signal sources after the instrument is powered on. Turn off signal sources before the instrument is powered off.

DO NOT REMOVE THE INSTRUMENT COVER

Only qualified, service-trained personnel who are aware of the hazards involved should remove the instrument covers. Always disconnect the power cable and any external circuits before removing the instrument cover.

MODULE COVERS

Always replace module covers after terminal wiring and before inserting into mainframe.

DO NOT OPERATE IN AN EXPLOSIVE ATMOSPHERE

Do not operate the instrument in the presence of flammable gases or fumes.

DO NOT MODIFY THE INSTRUMENT

Do not install substitute parts or perform any unauthorized modification to the product. Return the product to a Keysight Sales and Service Office for service and repair to ensure that safety features are maintained.

DO NOT MEASURE MORE THAN THE RATED VOLTAGE

Maximum voltage as marked on each module is as below:

- a) DAQM900A: 120 Vrms
 - b) DAQM901A, DAQM902A, DAQM903A, DAQM904A, DAQM908A: 300 Vrms
 - c) DAQM905A, DAQM907A: 42 Vpk
 - d) DAQM909A: +/-18Vpk (single ended) for both HI and LO pins.
-

DO NOT CONNECT ANY MODULE CHANNELS TO MAINS

Measurement category of the instrument is rated as CAT 'Others', terminals should not be directly connected to the mains.

AC POWER CORD

Removal of the AC power cord is the disconnect method to remove power from the instrument. Be sure to allow for adequate access to the power cord to permit disconnection from AC power. Use only the Keysight specified power cord for the country of use or one with equivalent ratings.

SELF-TEST

Before measuring any hazardous voltage or current, run the *TST? query from the remote interface, and read the result to verify that the instrument is performing properly. The *TST? query is a self-test that returns +0 if the instrument passes and +1 if the instrument fails. You can also perform this query from the front panel by pressing [Utility] > Self Test > Quick Test. If this self-test fails, make sure that the instrument is repaired and passes the self-test before continuing.

CAUTION

This is a sensitive measurement apparatus by design and may have some performance loss when exposed to ambient continuous electromagnetic phenomenon. Measurement Considerations – use shielded or twisted cable, use common mode choke, ferrite clamp and damping resistor before the input to DAQ970A/DAQ973A.







CLEANING

To prevent electrical shock, disconnect the instrument from AC mains power before cleaning. Clean the outside of the instrument with a soft, lint-free, slightly dampened cloth. Do not use detergent, volatile liquids, or chemical solvents. Do not attempt to clean internally. If needed, contact a Keysight Technologies Sales and Service Office to arrange for proper cleaning to ensure that safety features and performance are maintained.

NOTE

Connect USB cable with ferrite core to the rear panel USB port of the instrument.

Safety Symbol and Regulatory Markings

Symbol	Description
	Alternating current (AC).
	Protective earth (ground) terminal.
	Earth (ground) terminal.
	Caution, risk of danger (refer to the manual for specific Warning or Caution information).
	Frame or chassis (ground) terminal.
	Instrument cable lock.
	This product is marked with the ACMA RCM mark for compliance in Australia/New Zealand. A copy of the Manufacturer's Australia Declaration of Conformity for this instrument can be obtained by contacting your local Keysight Technologies Sales Representative.



This symbol indicates the time period during which no hazardous or toxic substance elements are expected to leak or deteriorate during normal use. Forty years is the expected useful life of the product.



The CSA mark is a registered trademark of the Canadian Standards Association, with the 'C' and 'US' subscript indicates the instrument is certified to the applicable Canadian and United States of America standards respectively.



The CE mark is a registered trademark of the European Community. This CE mark shows that the product complies with all the relevant European Legal Directives.

ICES/NMB-001 - This ISM device complies with the Canadian ICES-001.

Cet appareil ISM est conforme a la norme NMB-001 du Canada.

ISM GRP 1-A - This is an Industrial Scientific and Medical (ISM) Group 1 Class A product.



This symbol is a South Korean Class A EMC Declaration, with the product identification code "R-REM-Kst-GM16412".

R - Identification of authorization prefix.

REM - Identification of basic certification information.

Kst - Identification of applicant's information

GM16412 - Product identification.

This is a Class A instrument suitable for professional use and in electromagnetic environment outside of the home.

WARNING

The WARNING sign denotes a hazard. It calls attention to a procedure, practice, or the like, which, if not correctly performed or adhered to, could result in personal injury. Do not proceed beyond a WARNING sign until the indicated conditions are fully understood and met.

CAUTION

The CAUTION sign denotes a hazard. It calls attention to an operating procedure, or the like, which, if not correctly performed or adhered to, could result in damage to or destruction of part or all of the product. Do not proceed beyond CAUTION sign until the indicated conditions are fully understood and met.

NOTE

The NOTE sign denotes important information. It calls attention to a procedure, practice, condition or the like, which is essential to highlight. Safety and Regulatory Information 12

South Korean Class A EMC Declaration

Information to the user:

This instrument has been conformity assessed for used in business environments. In a residential environment this equipment may caused radio interference.

This EMC statement applies to the equipment only for use in business environment.

사용자 안내문

이 기기는 업무용 환경에서 사용할 목적으로 적합성 평가를 받은 기기로서 가정용 환경에서 사용하는 경우 전파간섭의 우려가 있습니다.

사용자 안내문은 "업무용 방송통신기자재"에만 적용한다.

Safety and EMC Requirements

This instrument is designed to comply with the following safety and EMC requirements:

Safety compliance

- IEC 61010-1:2010/EN 61010-1:2010; IEC 61010-2-030:2010/EN61010-2-030:2010
- Canada: CAN/CSA-C22.2 No.61010-1-12; CAN/CSA-C22.2 No. 61010-2-030-12
- USA: ANSI/UL Std. No. 61010-1:2012; ANSI/UL Std No.61010-2-030:2012

EMC compliance

- IEC 61326-1:2012 / EN 61326-1:2013
- Canada: ICES/NMB-001:2006
- Australia/New Zealand: AS/NZS CISPR 11:2011
- South Korea RRA Notice 2016-24

NOTE

Maximum transients on all inputs are limited to 1500 Vpk referenced to earth except for DAQM900A, DAQM905A, DAQM907A and DAQM909A which are 0 Vpk. Measurement is rated for CAT 'none', and terminals are not to be connected directly to mains. Do not use this equipment to measure circuits where transient over-voltages could exceed this level.

Environmental Conditions and General Characteristics

Keysight DAQ970A/DAQ973A is designed for indoor use and in an area with low condensation. Tables below show the general environmental requirements and general characteristics for this instrument.

Environmental condition	Requirement
Temperature	Operating condition: 0 °C to 55 °C Storage condition: -40 °C to 70 °C
Humidity	Operating condition: Up to 80% RH at 40 °C (non-condensing), decreasing linearly to 50% RH at 55 °C (non-condensing) Storage condition: Up to 50% RH at 55 °C (non-condensing)
Altitude	Up to 3000m
Pollution degree	2

The electrical (power) requirements of the DAQ970A/DAQ973A are summarized as below.

General characteristics	Requirement
Power supply	100 – 240 VAC (Mains supply voltage fluctuation is not allowed to exceed $\pm 10\%$)
Power line frequency	50/60/400 Hz
Power consumption	45 watts

WARNING

DO NOT OPERATE IN AN EXPLOSIVE ATMOSPHERE OR WET ENVIRONMENTS

Do not operate the instrument around flammable gases or fumes, vapor, or wet environments.

1 Introduction to the Instrument

- Instrument at a Glance
- Front Panel at a Glance
- Instrument Annunciators
- Rear Panel at a Glance
- Plug-In Modules at a Glance
- Dimension Diagram
- Remote Interface Configuration
- LAN Configuration Procedure
- Firmware Update
- Contacting Keysight Technologies

This chapter introduces the overview and basic functionality of the DAQ970A/DAQ973A.

Instrument at a Glance

The DAQ970A/DAQ973A combines precision measurement capability with flexible signal connections for your production and development test systems. Three module slots are built into the rear of the instrument to accept any combination of data acquisition or switching modules. The combination of USB data logging and data acquisition features make this instrument a versatile solution for your testing requirements now and in the future.

Easily display, save, and document your measurement results

- High usability with an intuitive, menu driven user interface.
- Histogram, trend chart, meter and numeric views on a high-resolution color display.
- Supported on both LAN and USB interfaces.
- Drag and drop, driverless USB connectivity.

Convenient data logging features

- Direct measurement of temperature (thermocouples, RTDs, and thermistors), strain, DC voltage, AC voltage, 2-wire and 4-wire resistance, frequency, period, diode, capacitance, DC current, and AC current.
- Patented, metrology-level performance that serves as the foundation for all measurements.
- Interval scanning with storage of up to 1,000,000 time-stamped readings.
- Independent channel configuration with function, measurement scaling, and alarm limits available on a per-channel basis.
- Intuitive user interface with knob cursor navigation keypad, data entry from both softkeys (menu keys inside the screen view) and hardkeys (menu keys in front of the instrument).
- Portable, rugged case with non-skid feet.
- BenchVue Data Acquisition (DAQ) software for Microsoft® Windows® available for download from www.keysight.com/find/benchvue.

Flexible data acquisition/ switching features

- Up to 60 channels per instrument (120 single-ended channels).
- Reading rates are more than 5,000 readings per second on a single channel and scan rates up to 450 channels per second.
- Choice of multiplexing, matrix, general-purpose Form C switching, RF switching, digital I/O, totalize, DAC output, and DAC readback functions.
- Built-in Web Interface for monitoring and controlling the instrument via a Web browser.

Programming language

- Compatible with SCPI (Standard Commands for Programmable Instruments) programming language.



Front Panel at a Glance



Label	Description
1	USB Port
2	On/Standby switch with LED indicator
3	Display
4	Softkeys
5	Measurement operation menu (to control the initiation of the measurements)
6	Measurement configuration menu (to set parameters for measurements)
7	Knob
8	Cursor navigation keypad









Front panel key

NOTE

Press the  key to return the instrument into local control when the instrument is in remote (indicated by the  annunciator).

Instrument Annunciators

The table below shows the various annunciators that are available on the DAQ970A/DAQ973A. The annunciators will be shown on the top of the display when the corresponding conditions are met.

Annunciator	Description
	Monitor mode enabled.
	Digitizing is in progress.
	Scanning/DMM digitizing is in progress.
	A – Alarms are present in the alarm queue. H1234L – A High or Low alarm condition has occurred.
	Internal DMM is disabled. Instrument configured for an external scan interval when DMM is Off.
	Reading memory overflowed at 1,000,000 readings. New readings will overwrite the oldest readings.
	A USB drive is inserted in the front panel USB host port.
	Instrument is in remote (remote interface)
	Errors are present in the error queue. Press [View] > Errors to view the list of errors.

Rear Panel at a Glance



Label	Description
1	Slot identifier (100, 200, 300)
2	GPIB interface (Available on the DAQ973A only)
3	AC mains input
4	LAN interface connector
5	USB interface connector
6	External trigger input, alarm outputs, channel advance input, and channel close output
7	Chassis ground screw

Plug-In Modules at a Glance

The DAQ970A/DAQ973A offers a complete selection of plug-in modules to provide a high quality measurement, switching, and control capabilities. For more details, see [Module Overview](#).

Supported modules on the DAQ970A/DAQ973A:

- DAQM900A 20-Channel FET Multiplexer Module
- DAQM901A 20-Channel Armature Multiplexer Module
- DAQM902A 16-Channel Reed Multiplexer Module
- DAQM903A 20-Channel Actuator/General-Purpose Switch Module
- DAQM904A 4x8 Two-Wire Matrix Switch Module
- DAQM905A Dual 1:4 RF Multiplexer (50 Ω) Module
- DAQM907A Multifunction Module
- DAQM908A 40-Channel Single-Ended Multiplexer Module
- DAQM909A 4-Channel 24-Bit Digitizer Module

NOTE

Refer to the product data sheet at <http://literature.cdn.keysight.com/litweb/pdf/5992-3168EN.pdf> for a complete specifications on all the supported modules.

Dimension Diagram

Bench dimension:

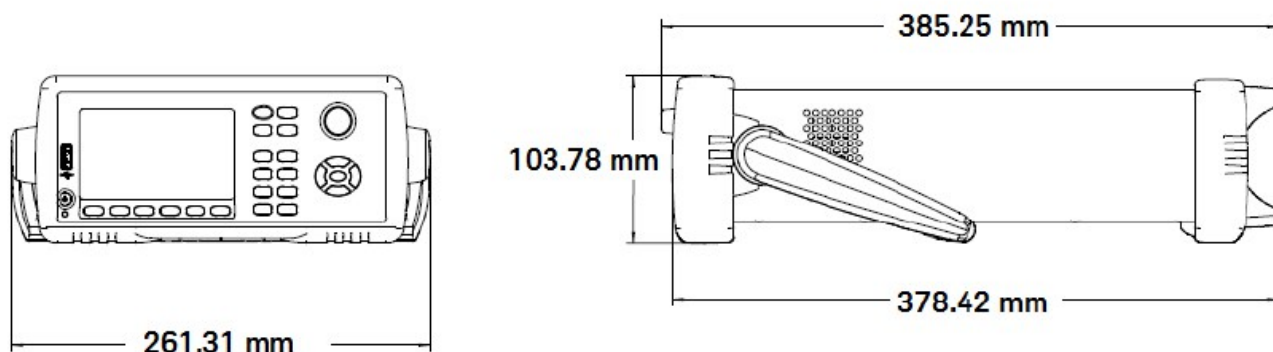

Rack dimension:

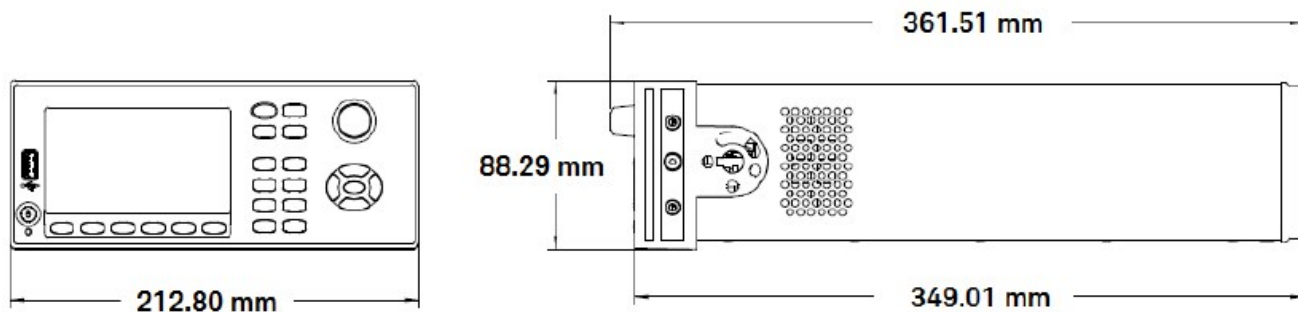

Module dimension:

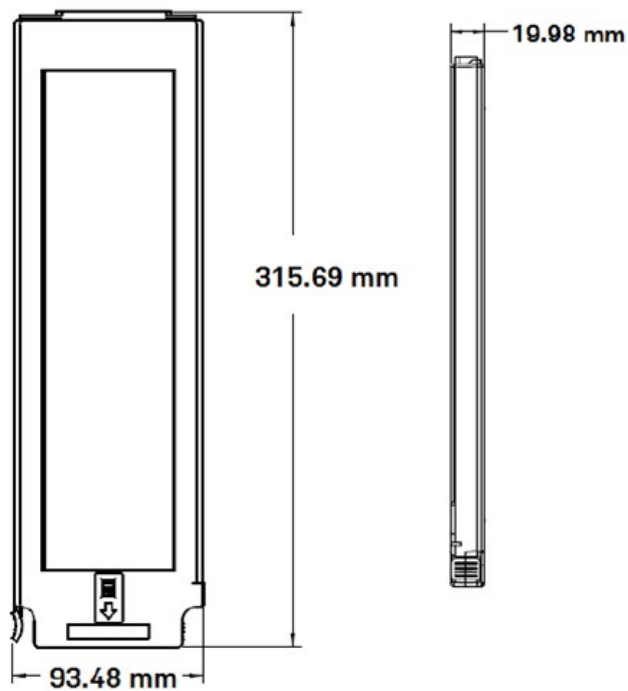

Remote Interface Configuration

WARNING

REMOTE OPERATION

When any channel is connected to a hazardous voltage source, the instrument and the device under test should be supervised, following local EHS practices to restrict access.

NOTE

If Secure mode is enabled, the instrument must be unlocked with the correct security code to perform many of these actions. See **Security** for more information.

The DAQ970A supports remote interface communication over LAN and USB interfaces. The DAQ973A however supports an additional GPIB interface on top of LAN and USB interface. All the interfaces are "live" at power up when the instrument ships from the factory.

- **LAN Interface:** By default, the DHCP (Dynamic Host Configuration Protocol) is on, a protocol for assigning dynamic IP addresses to network devices, which may enable communication over LAN. With dynamic addressing, a device can have a different IP address every time it connects to the network. See **LAN Settings** for more information.
- **USB Interface:** Use the rear panel USB interface connector to communicate with the instrument using your PC. See **USB Settings** for more information.
- **GPIB Interface (DAQ973A only):** Set the instrument's GPIB address and connect to your PC using a GPIB cable.

Keysight IO Libraries Suite

NOTE

Ensure that the Keysight IO Libraries Suite is installed before you proceed for the remote interface configuration.

Keysight IO Libraries Suite is a collection of free instrument control software that automatically discovers instruments and allows you to control instruments over LAN and USB interfaces. For more information, or to download the IO Libraries, go to www.keysight.com/find/iosuite.

GPIB Settings (DAQ973A only)

Each device on the GPIB (IEEE-488) interface must have a unique whole number address between 0 and 30. The instrument ships with a default address of 9, and the GPIB address is displayed at power-on.

This setting is non-volatile; it will not be changed by power cycling or *RST or SYSTem:PRESet. Your computer's GPIB interface card address must not conflict with any instrument on the interface bus.

Front panel	Remote interface
Press [Home] > User Settings > I/O > GPIB .	SYSTem:COMMunicate:GPIB:ADDRes <address>
From this menu, you can set the GPIB address and turn GPIB on or off. After making changes, you must cycle power on the instrument for the change to take effect.	SYSTem:COMMunicate:ENABLE {ON 1 OFF 0},GPIB

LAN Settings

The following sections describe the primary front panel LAN configuration functions, including SCPI commands where applicable. In the *DAQ970A/DAQ973A Programming Guide*, see "SYSTEM Subsystem - Remote Interface Configuration Commands" for all LAN configuration commands.

NOTE

Some LAN settings require you to cycle power to activate them. The instrument briefly displays a message when this is the case. Observe the display closely as you change the LAN settings.

Enable or disable LAN interface

Front panel	Remote interface
Press [Home] > User Settings > I/O > LAN Set the softkey to On or Off	SYSTem:COMMunicate:ENABle {OFF ON}, LAN

View the LAN status, MAC status, and current LAN configuration settings

Once the LAN interface is enabled, you can view the LAN status, MAC address, and current LAN configuration settings from the front panel. The LAN status may be different from the front panel configuration menu settings, which depends on the network configuration. If the settings are different, it is because the network has automatically assigned its own settings. If the instrument goes into remote, all LAN changes will be disabled and the display will go into a different screen. Re-selecting with LAN Settings page will display the new settings if a LAN restart took place.

Front panel	Remote interface
Press [Home] > User Settings > I/O > LAN Settings	(none)

Modify Settings

As shipped from the factory, the instrument pre-configured settings (DHCP is on) should work in most LAN environments. However, if you wish to manually set an IP address, Subnet Mask, or Default Gateway, turn DHCP off, then change the IP setup as described below.

Manual/DHCP

The DHCP can automatically assign a dynamic IP address to a LAN device. This is typically the easiest way to configure the instrument for LAN. This setting is non-volatile, it will not be changed by cycling power, factory reset (*RST command), or instrument preset (SYSTem:PRESet command).

Disabling DHCP will enable the Manual setting, and vice versa.

Front panel	Remote interface
Press [Home] > User Settings > I/O > LAN Settings > Modify Settings.	SYSTem:COMMunicate:LAN:DHCP {OFF ON}

To enable DHCP:

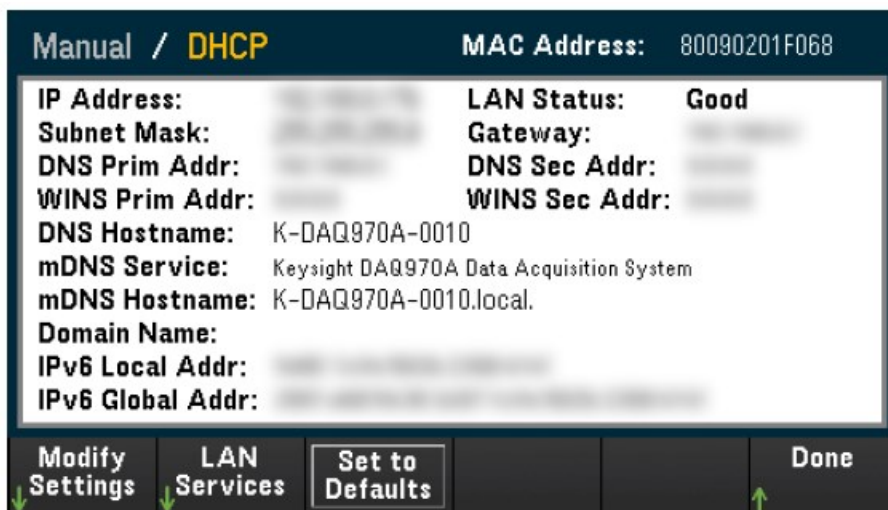

Step	Front panel	Remote interface
1	Press [Home] > User Settings > I/O > LAN Settings > Modify Settings. Set the first softkey to DHCP.	SYSTem:COMMunicate:LAN:DHCP ON
2	If you change this parameter, you must press [Done] > [Apply Changes] for the change to take effect.	SYSTem:COMMunicate:LAN:UPDate

To disable DHCP:

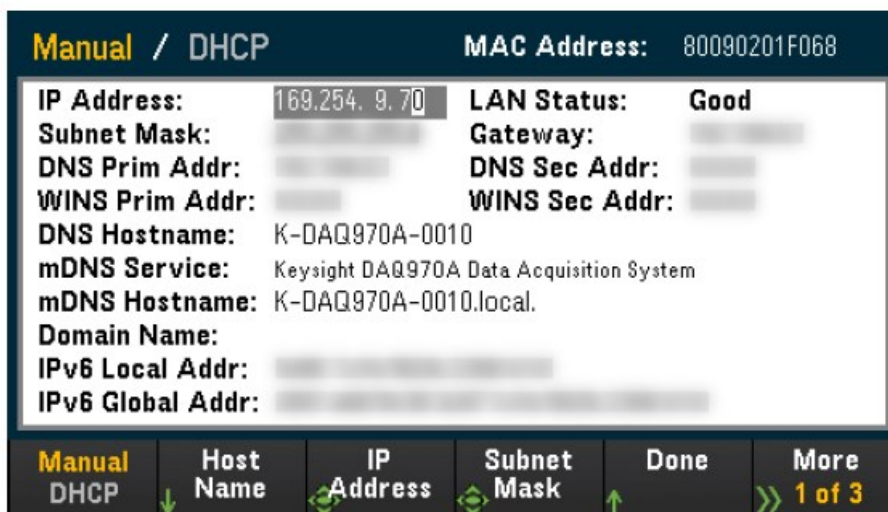

Step	Front panel	Remote interface
1	Press [Home] > User Settings > I/O > LAN Settings > Modify Settings. Set the first softkey to Manual.	SYSTem:COMMunicate:LAN:DHCP OFF
2	If you change this parameter, you must press [Done] > [Apply Changes] for the change to take effect.	SYSTem:COMMunicate:LAN:UPDate

Once DHCP is disabled, the following parameters will be available for manual setup:

- Host Name
- IP Address
- Subnet Mask
- Gateway
- Primary and Secondary DNS
- Primary and Secondary WINS
- Service mDNS

Host Name

A hostname is the host portion of the domain name, which is translated into an IP address.

Step	Front panel	Remote interface
1	Press [Home] > User Settings > I/O > LAN Settings > Modify Settings . Set the first softkey to Manual and press Host Name to enter the host name.	SYSTem:COMMunicate:LAN:HOSTname
2	If you change this parameter, you must press [Done] > [Done] > [Apply Changes] for the change to take effect.	SYSTem:COMMunicate:LAN:UPDate

Each instrument is shipped with a default host name with the format: K-modelnumber-serialnumber, where modelnumber is the instrument's 7-character model number (e.g. DAQ970A), and serialnumber is the last five characters of the 10-character instrument serial number located on the label on the top of the unit (e.g. 45678 if the serial number is MY12345678).

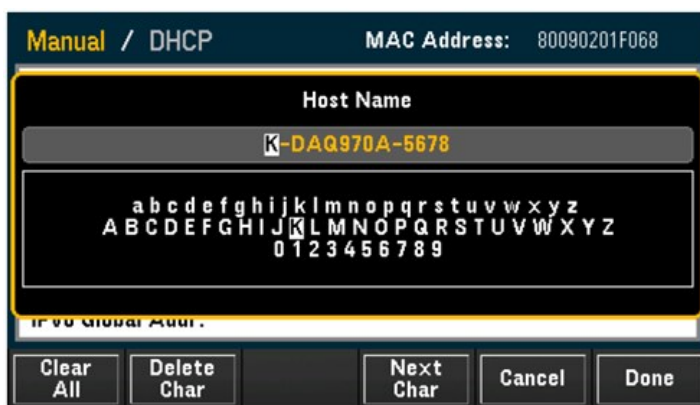

- The instrument receives a unique hostname at the factory, but you may change it. The hostname must be unique on the LAN.
- The name must start with letter, other characters can be an upper or lower case letters, numeric digits, or dashes "-".
- This setting is non-volatile, it will not be changed by cycling power, factory reset (*RST command), or instrument present (SYSTem:PRESet command).

IP Address

You can enter a static IP address for the instrument as a four-byte integer expressed in dot notation. Each byte is a decimal value, with no leading zeros (for example, 169.254.2.20). Refer to [More about IP Addresses and Dot Notation](#) for further details.

Step	Front panel	Remote interface
1	Press [Home] > User Settings > I/O > LAN Settings > Modify Settings . Set the first softkey to Manual and press IP Address to set the desired IP address.	SYSTem:COMMunicate:LAN:IPAdDress
2	If you change this parameter, you must press [Done] > [Apply Changes] for the change to take effect.	SYSTem:COMMunicate:LAN:UPDate

- If DHCP is on, it attempts to assign an IP address to the instrument. If it fails, Auto-IP attempts to assign an IP address to the instrument.
- Contact your LAN administrator to obtain an IP address.
- This setting is non-volatile, it will not be changed by cycling power, factory reset (*RST command), or instrument present (SYSTem:PRESet command).

Subnet Mask

Subnetting allows the LAN administrator to subdivide a network to simplify administration and minimize network traffic. The subnet mask indicates the portion of the host address used to indicate the subnet.

Step	Front panel	Remote interface
1	Press [Home] > User Settings > I/O > LAN Settings > Modify Settings . Set the first softkey to Manual and press Subnet Mask to set the desired subnet mask address.	SYSTem:COMMunicate:LAN:SMASK
2	If you change this parameter, you must press [Done] > [Apply Changes] for the change to take effect.	SYSTem:COMMunicate:LAN:UPDate

- Contact your LAN administrator to obtain an IP address.
- This setting is non-volatile, it will not be changed by cycling power, factory reset (*RST command), or instrument present (SYSTem:PRESet command).

Gateway

A gateway is a network device that connects networks. The default gateway setting is the IP address of the instrument.

Step	Front panel	Remote interface
1	Press [Home] > User Settings > I/O > LAN Settings > Modify Settings . Set the first softkey to Manual and press Gateway to set the desired gateway address.	SYSTem:COMMunicate:LAN:GATEway
2	If you change this parameter, you must press [Done] > [Apply Changes] for the change to take effect.	SYSTem:COMMunicate:LAN:UPDate

- **Do not set a gateway address when DHCP is enabled (factory default).**
- Contact your LAN administrator to obtain an IP address.
- This setting is non-volatile, it will not be changed by cycling power, factory reset (*RST command), or instrument present (SYSTem:PRESet command).

Primary and Secondary DNS

A DNS (Domain Name Service) is an Internet service that translates domain names into IP addresses. The DNS server address is the IP address of a server that performs this service.

Step	Front panel	Remote interface
1	Press [Home] > User Settings > I/O > LAN Settings > Modify Settings . Set the first softkey to Manual and press Primary DNS or Second DNS to set the desired DNS address.	SYSTem:COMMunicate:LAN:DNS[{{1 2}}] Note: The [{{1 2}}] syntax indicates the type of primary (1) or secondary (2) DNS server address.
2	If you change this parameter, you must press [Done] > [Apply Changes] for the change to take effect.	SYSTem:COMMunicate:LAN:UPDate

- **Normally, DHCP discovers the DNS address information; you only need to change this if DHCP is unused or non-functional.**
- Contact your LAN administrator to obtain an IP address.
- This setting is non-volatile, it will not be changed by cycling power, factory reset (*RST command), or instrument present (SYSTem:PRESet command).

Primary and Secondary WINS

A WINS (Windows Internet Name System) is a system that enables Windows to identify NetBIOS systems on a TCP/IP network.

Step	Front panel	Remote interface
1	Press [Home] > User Settings > I/O > LAN Settings > Modify Settings . Set the first softkey to Manual and press Primary WINS or Second WINS to set the desired WINS address.	SYSTem:COMMunicate:LAN:WINS[{{1 2}}] Note: The [{{1 2}}] syntax indicates the type of primary (1) and secondary (2) WINS server address.
2	If you change this parameter, you must press [Done] > [Apply Changes] for the change to take effect.	SYSTem:COMMunicate:LAN:UPDate

- Normally, DHCP discovers the WINS address information; you only need to change this if DHCP is unused or nonfunctional.
- Contact your LAN administrator to obtain an IP address.
- This setting is non-volatile, it will not be changed by cycling power, factory reset (*RST command), or instrument present (SYSTem:PRESet command).

Service mDNS

A mDNS (multicast Domain Name Service) is an Internet service that is registered with the selected naming service.

Step	Front panel	Remote interface
1	Press [Home] > User Settings > I/O > LAN Settings > Modify Settings . Set the first softkey to Manual and press Service mDNS on the third page of the menu to set the desired mDNS service name.	LXI:MDNS:SNAME:DESired
2	If you change this parameter, you must press [Done] > [Apply Changes] for the change to take effect.	SYSTem:COMMunicate:LAN:UPDate

Each instrument is shipped with a default service name with the format:

Keysight Technologies_<modelNumber>_ - serial

Number where modelNumber is the instrument 7-character model number (DAQ970A) and product name (Data Acquisition System), and serialNumber is the last five characters of the 10-character instrument serial number located on the label on top of the unit (e.g. 45678 if the serial number is MY12345678).

- The instrument receives a unique mDNS service name at the factory, but you may change it. The mDNS service name must be unique on the LAN.
- The name must start with letter, other characters can be an upper or lower case letters, numeric digits, or dashes "-".
- This setting is non-volatile, it will not be changed by cycling power, factory reset (*RST command), or instrument present (SYSTem:PRESet command).

LAN Restart

Any modification on the LAN settings described above will restart the LAN after pressing Apply Changes. This feature restarts the networking using ALL current LAN settings. LAN restart does not clear the Web Interface password.

Remote interface

LXI:REStart

LAN Services

Enables (On) or disables (Off) LAN services on the instrument.

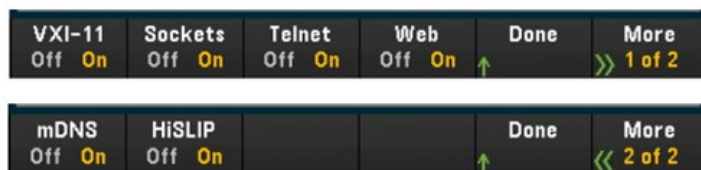

Step	Front panel	Remote interface
1	Press [Home] > User Settings > I/O > LAN Settings > LAN Services Press On to enable or Off to disable each setting.	(none)
2	If you change this parameter, you must press [Done] > [Apply Changes] for the change to take effect.	SYSTem:COMMunicate:LAN:UPDate

- Refer to the Keysight IO Libraries help for information on the VXI-11, Sockets, and HiSLIP protocols.
- Telnet - The instrument telnet port is 5024. Open SCPI sessions on the Telnet connection by entering: telnet IP address 5024
- Web - Enable or disable instrument programming from the instrument's Web Interface.
- mDNS - mDNS service is for use in networks where no conventional DNS server is installed. Cycling power or resetting the LAN always enables mDNS.

Set to Defaults

This feature resets the LAN settings to the respective factory default values.

Front panel	Remote interface
Press [Home] > User Settings > I/O > LAN Settings > Set to Defaults	(None)

LAN Reset

Resets the LAN using its current settings and enables DHCP mode and mDNS service. The LAN reset also clears any user-defined Web user interface (Web UI) password.

Front panel	Remote interface
Press [Home] > User Settings > I/O > LAN Reset	LXI:RESet

Web Interface

The DAQ970A/DAQ973A includes a built-in Web Interface for remote instrument access and control over LAN via a Web browser. Further details, refer to [Web Interface](#).

More about IP Addresses and Dot Notation

Dot-notation addresses ("nnn.nnn.nnn.nnn" where "nnn" is a byte value from 0 to 255) must be expressed with care, as most PC web software interprets byte values with leading zeros as octal (base 8) numbers. For example, "192.168.020.011" is actually equivalent to decimal "192.168.16.9" due to ".020" is interpreted as "16" expressed in octal, and ".011" as "9". To avoid confusion, use only decimal values from 0 to 255, with no leading zeros.

USB Settings

USB Settings configures the front panel USB (storage) and rear panel USB (connectivity) connectors



Front panel	Remote interface
Press [Home] > User Settings > I/O > USB Settings	SYSTEM:COMMunicate:ENABLE {OFF ON}, USB

USB SCPI

USB SCPI enables (On) or disables (Off) the instrument's USB control port on the rear panel. Once the interface state is changed, you must cycle the instrument power for the change to take effect. When disabled, the interface cannot be configured in the Keysight IO Libraries Connection Expert utility.

Easy File Access (File Access Softkey)

Easy File Access allows you to easily transfer files between the instrument and your PC. Simply connect the rear panel USB control port on the instrument to a USB port on your PC and then use the window that appears on your PC to copy files from the instrument to your PC.

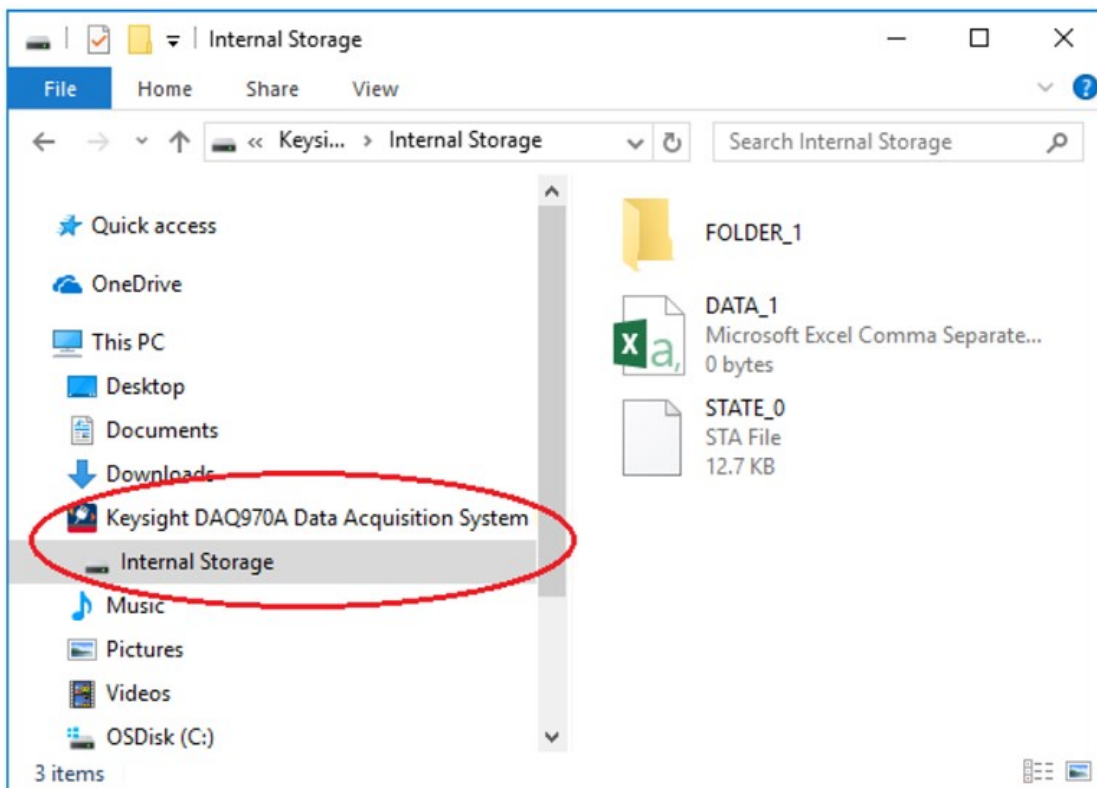

You can use your PC's standard file management features to copy files from the instrument to your PC.

NOTE

To use Easy File Access at the same time that you are remotely programming the instrument with SCPI over the USB interface (USB SCPI), you must have Keysight IO Libraries Suite 16.3 or later installed on your PC. You may download the latest version at www.keysight.com/find/iosuite.

To use Easy File Access on a PC running the Windows XP operating system, make sure you have Microsoft Windows Media Player 11 for Windows XP SP1, or are using a Microsoft Windows XP SP2, SP3, or a newer version of Windows. You may download this software at www.microsoft.com/en-us/-download/details.aspx?id=8163.

Show USB ID

Displays the USB address string as used in VISA programming applications

Technical Connection Details

In most cases, you can easily connect to the instrument with the IO Libraries Suite or Web interface. In certain circumstances, it may be helpful to know the following information.

Interface	Details
LAN	VISA String: TCPIP0::<IP Address>::inst0::INSTR Example: TCPIP0::192.168.10.2::inst0::INSTR
Web Interface	Port number 80, URL <a href="http://<IP address>">http://<IP address>
USB	USB ID is in the form of USB0::<Vendor ID>::<Prod ID>::<Serial Number>::0::INSTR Example: USB0::0x2A8D::0x0902::MY55160003::0::INSTR

LAN Configuration Procedure

There are several parameters that you might need to set to establish network communication using the LAN interface. Primarily, you will need to establish an IP address. You might need to contact your network administrator for help in establishing communication with the LAN interface.

NOTE

If Secure mode is enabled, the instrument must be unlocked with the correct security code to perform many of these actions. See [Security](#) for more information.

1. Press [Home] > User Settings > I/O > LAN Settings.
2. You can select **Modify Settings** to change the LAN settings, select **LAN Services** to enable (On) or disable (Off) LAN services on the instrument, or select **Set to Defaults** to restore the LAN settings to its factory default settings.

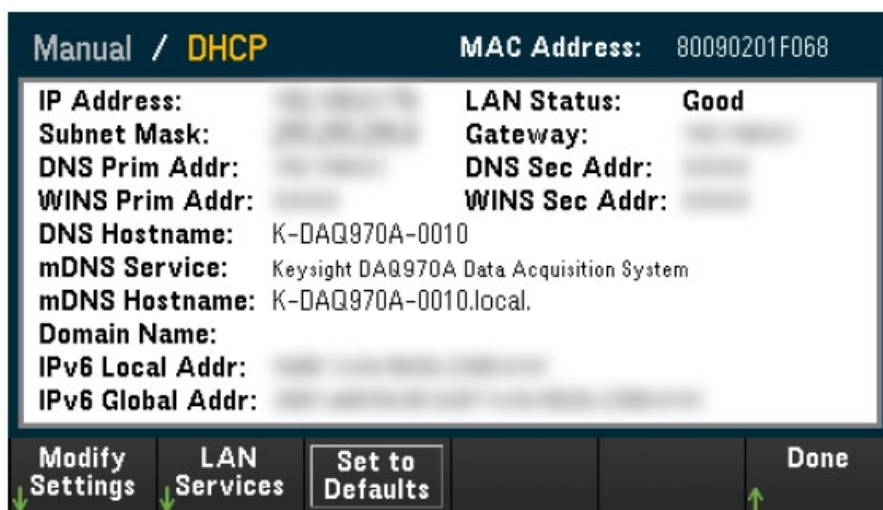

3. To change settings, press **Modify Settings**. To access most items on this screen, use the first softkey to switch from **DHCP** to **Manual**. With DHCP on, an IP address will automatically be set by the DHCP (Dynamic Host Configuration Protocol) when you connect the instrument to the network; provided that the DHCP server is found and is able to do so. The DHCP also automatically deals with the subnet mask, gateway address, DNS, WINS, and domain name, if required. This is typically the easiest way to establish LAN communication for your instrument; all you need to do is leave the DHCP on. Contact your LAN administrator for details.
4. **Establish an "IP Setup"**
If you are not using DHCP (the first softkey is set to Manual), you must establish an IP setup, including an IP address, and possibly a subnet mask and gateway address. The IP Address and Subnet Mask softkeys are on the main screen. Press More to configure other settings.

Contact your network administrator for the IP address, subnet mask, and gateway to use. All IP addresses take the dot-notation form "nnn.nnn.nnn.nnn" where "nnn" in each case is a byte value in the range 0 through 255. You can enter a new IP address using the knob or the front panel arrow keys. **Do not enter leading zeros.**

5. **Configure the "DNS Setup" (optional)**

The DNS (Domain Name Service) is an Internet service that translates domain names into IP addresses. Ask your network administrator whether the DNS is in use, and if it is, for the host name, domain name, and DNS server address to use.

- a. Set the "hostname". Press **Host Name** and enter the hostname. A hostname is the host portion of the domain name, which is translated into an IP address. The hostname is entered as a string using the front panel arrow keys to select and change characters. The hostname may include letters, numbers, and dashes ("-").
- b. Set the "DNS Server" addresses. From the LAN configuration screen, press **More** to go to the second of three sets of softkeys.

Enter the **Primary DNS** and **Second DNS**. See your network administrator for details.

Firmware Update

CAUTION

Do not turn off the instrument during the update.

1. Press **[Home]** > **Help** > **About** to determine the firmware revision that is currently installed.
2. Go to www.keysight.com/find/DAQ970Afirmware to find the latest firmware revision. If this matches the revision installed on your instrument, there is no need to continue with this procedure. Otherwise, download the firmware update utility and a ZIP file of the firmware. Detailed firmware instructions are in the Firmware Update Utility Instructions located on the download page.
3. Unzip the ZIP file and use the firmware update utility to prepare a USB drive with the updated firmware.
4. Attach the USB drive to the instrument front panel and press **[Utility]** > **Admin** > **Firmware Update** to update the firmware. If Secure mode is enabled, unlock the instrument with the security code before installing firmware.

Important: In order to update the instrument firmware from remote, the model number in the *IDN? response must match the actual instrument model number. If you have changed the instrument's *IDN? response to another instrument, when attempting to update the firmware from remote, you will see this error: "The instrument is not supported by this firmware file". To update the firmware, either update using the front panel procedure or, from remote, use SYSTem:PERSonA:MODeL to set the *IDN? to match the actual model number, update the firmware, and then use SYSTem:PERSonA:MODeL again to set the *IDN? response to the other model number.

Contacting Keysight Technologies



You can contact Keysight Technologies for warranty, service, or technical support.

In the United States: (800) 829-4444

In Europe: 31 20 547 2111

In Japan: 0120-421-345

Use www.keysight.com/find/assist to contact Keysight worldwide, or contact your Keysight Technologies representative.

2 Quick Start

Prepare Instrument for Use

Module Wiring Connection and Installation

Connect Power and I/O Cables

Use the Built-In Help System

Adjust the Carrying Handle

Rack Mounting the Instrument

Keysight BenchVue Data Acquisition (DAQ) Software

Prepare Instrument for Use

Verify that you received the following items. If anything is missing, please contact your nearest Keysight sales office or Keysight authorized reseller.

- Power cord (for country of destination)
- Certificate of calibration (optional)
- Supplemental documentation packet
- USB 2.0 cable
- One J-type thermocouple and a flat blade screwdriver

The Keysight BenchVue Data Acquisition (DAQ) Software can be downloaded from www.keysight.com/find/benchvue.

Any plug-in modules that you ordered are delivered in a separate shipping container.

An additional cable kit (50 Ω) is also included when you order the DAQM905A Dual 1:4 RF Multiplexer (50 Ω) Module.

The latest product documentation is available at:

- www.keysight.com/find/DAQ970A
- www.keysight.com/find/DAQ973A

Module Wiring Connection and Installation

WARNING

To prevent electrical shock, use only wires that are rated for the maximum voltage applied to any channel.

Before removing a module cover, turn off all power to external devices that are connected to the module.

When any channel is connected to a hazardous voltage source, all channels in the module should be treated as hazardous.

When any channel is connected to a hazardous voltage source, all channel wiring in the module should be rated for the maximum voltage applied.

When any channel is connected to a hazardous voltage source, thermocouples attached to any other channel on the module shall have insulation rated for the maximum voltage, or have additional insulation added rated for the maximum voltage, and will be isolated from conductive parts using a thermal compound or tape rated for the maximum voltage applied.

Do not mount, move or remove any thermocouples when the device under test is connected to a signal source.

When any channel is connected to a hazardous voltage source, the instrument and the device under test should be supervised, following local EHS practices to restrict access.

CAUTION

During power on, any action to install or uninstall the modules from the rear panel will reboot the instrument.

Installing the Module

To connect wiring to a module and install to the rear panel of the instrument, follow the five steps shown below:

1. Using a flat head screwdriver, push the tab forward and lift up the cover to detach it from the module.

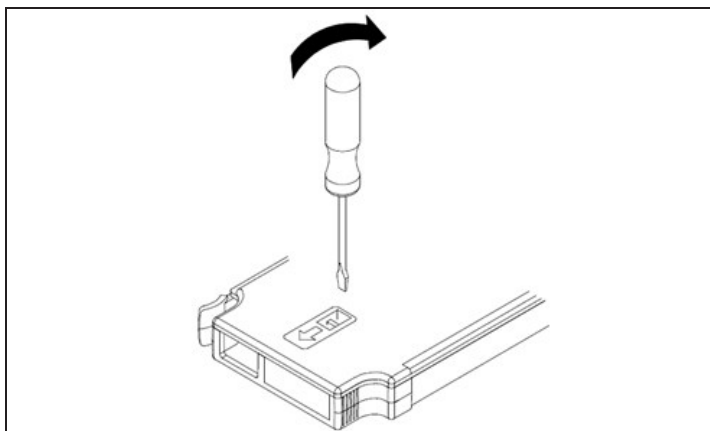

2. Connect the wiring to the screw terminals

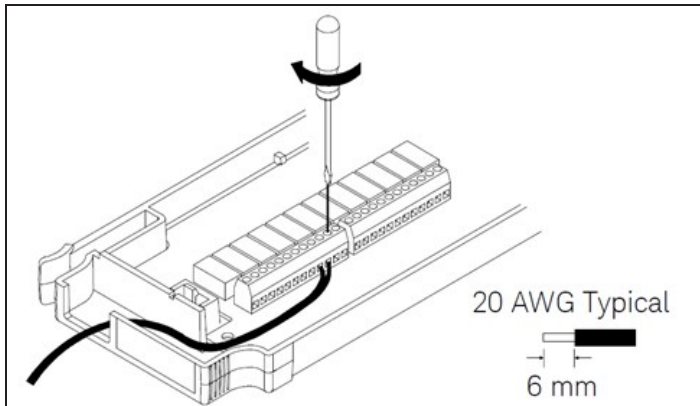

3. Route the wiring through the strain relief.

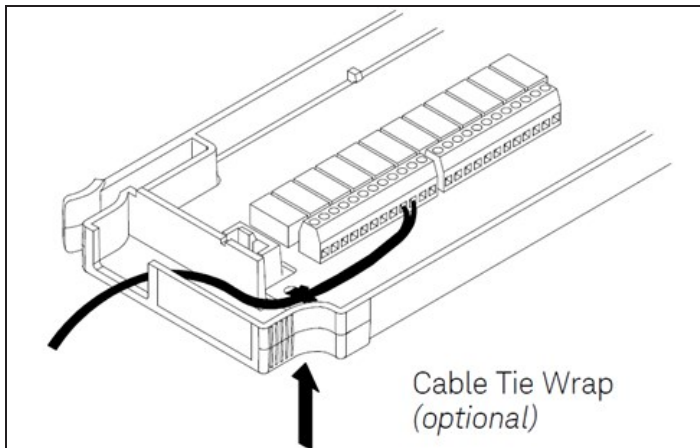

4. Replace the module cover.

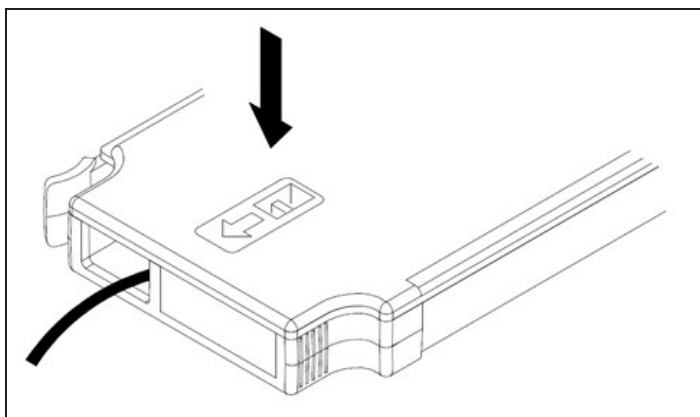

5. Install the module in to the instrument (at the rear panel)

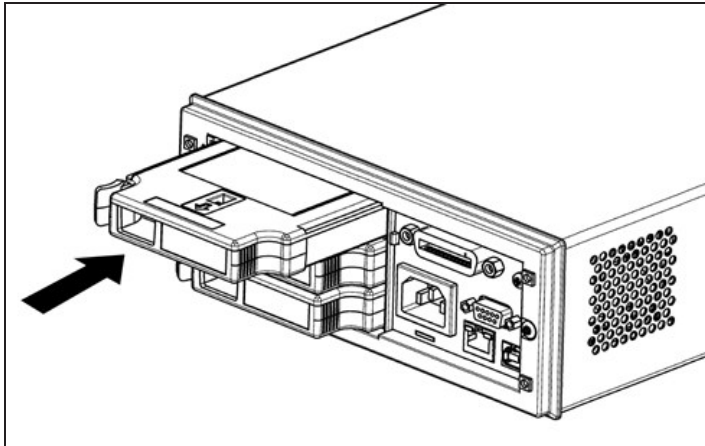

Uninstalling the Module

To unplug or replace any modules, push the clip located at the rear left side of the module inwards, and then pull it out from rear panel.

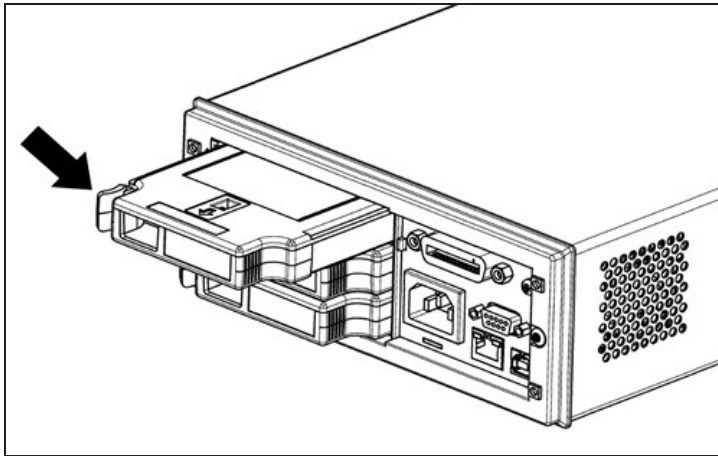

Connect Power and I/O Cables

To turn on the instrument

Before powering on the instrument, make sure all signal sources are turned off. Turn on signal sources after the instrument is powered on. Turn off signal sources before the instrument is powered off. Connect the power cord and LAN or USB cable as desired. Press the On/Standby switch on the front panel. Note that this switch is for standby purpose only. To disconnect the mains from the instrument, remove the power cord. If the instrument does not turn on, verify that the power cord is firmly connected.

The table below shows the statuses of the LED color displayed while the instrument is powered-on:

LED color	Instrument Status
LED off	No AC mains power connected.
LED is amber	Instrument is in standby mode with AC mains power still connected
LED is green	Instrument is turned on.

Power-on self test

After turning on, the instrument runs a power-on self test and displays a message on how to obtain help, along with the current IP address.

The front-panel display will light up briefly while the instrument perform its power-on self test, with all measurement channels turned off. If the power-on self test fails, the error annunciator, **ERR** is displayed on the screen. See "SCPI Error Messages" in the *DAQ970A/DAQ973A Programming Guide* for more information on SCPI error codes and error messages.

NOTE

A complete self-test performs a more extensive set of tests than those performed at power-on. See the *DAQ970A/DAQ973A Service Guide* for more information on the instrument complete self-test procedure.

The instrument's default measurement function is DC voltage (DCV), with autoranging enabled.

To turn off the instrument

Press and hold the On/Standby switch for about half a second. This prevents you from accidentally turning off the instrument by brushing against the power switch.

NOTE

If you turn off the instrument by disconnecting the power source (this is not recommended), the instrument turns on as soon as the power is reconnected. You do need to press the **On/Standby** switch again.

Use the Built-In Help System

The built-in help system provides context-sensitive help on any front panel key or menu softkey. A list of help topics is also available to help you learn about the instrument. All messages, context-sensitive help, and help topics appear in the selected language. The menu softkey labels are not translated.

View the list of help topics

Press [Home] > Help > Help Topics to view the list of help topics. Use the knob or the front panel arrow keys to highlight the desired topic, and press [Select] to view the help contents.

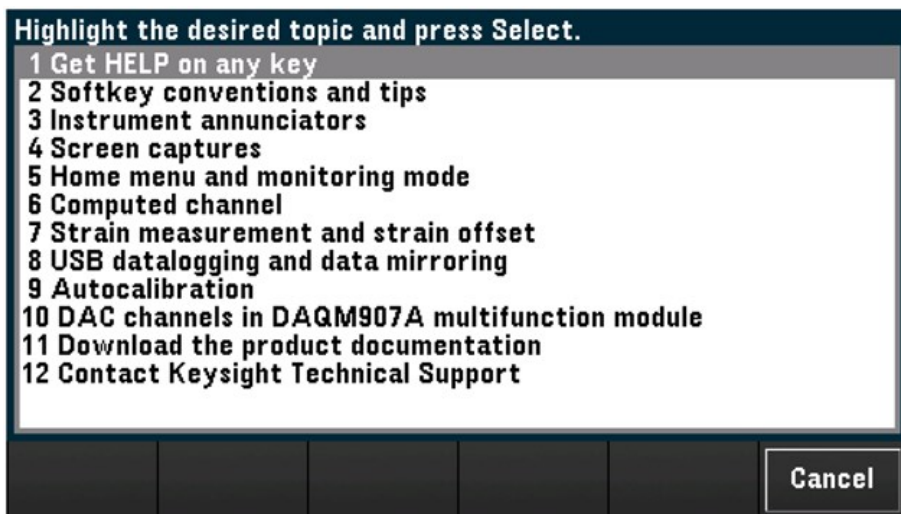

In this example, 1 Get HELP on any key was selected. The following help topic appears on the display:

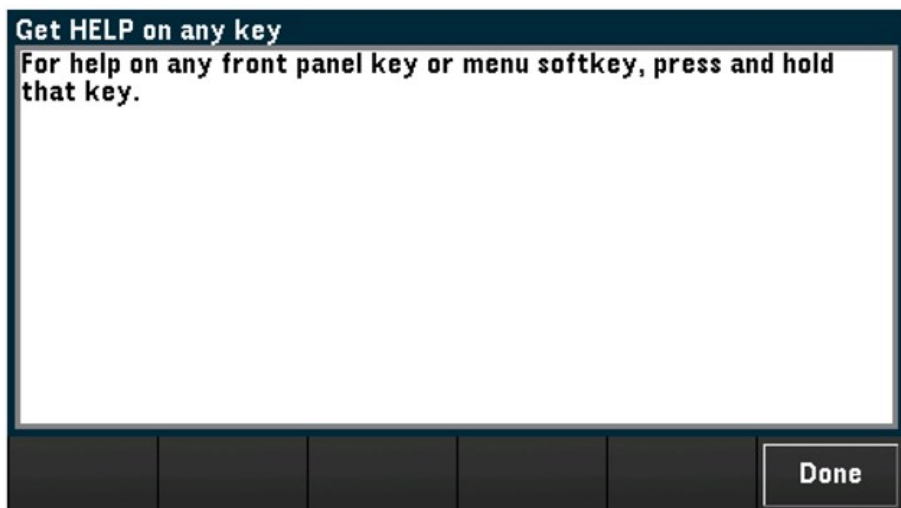

Press Done to exit the help.

View the help information for a front panel key

Press and hold any front panel key or softkey to get context-sensitive help, such as **[Scan]**. If the message contains more information than will fit on the display, use the knob or the front panel arrow keys to load in previous/next page.

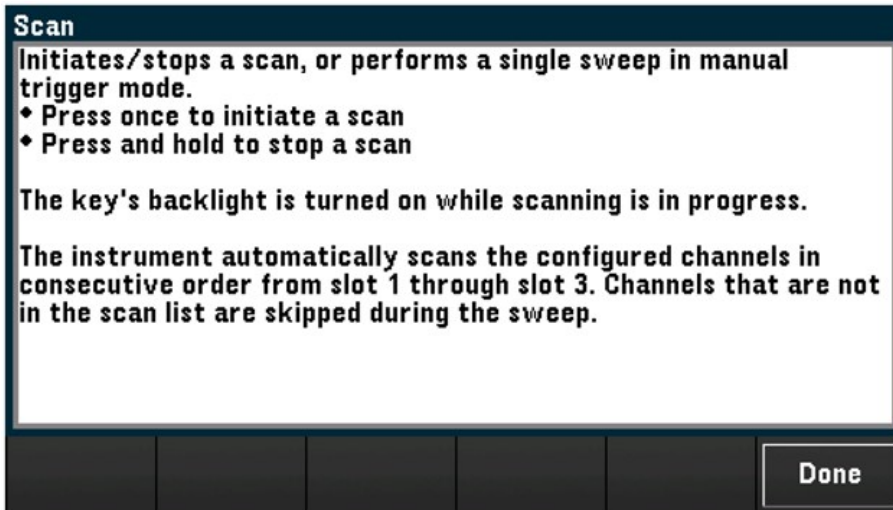

Press **Done** to exit the help.

View the instrument information

Press **[Home]** > **Help** > **About** to view the instrument information such as product serial number, IP address (when connected to LAN interface), and currently installed firmware revision. Press **Done** to exit.

Adjust the Carrying Handle

The carrying handle has three positions (as shown below). To adjust the handle position, grasp the sides of the handle, pull outward, and rotate the handle.

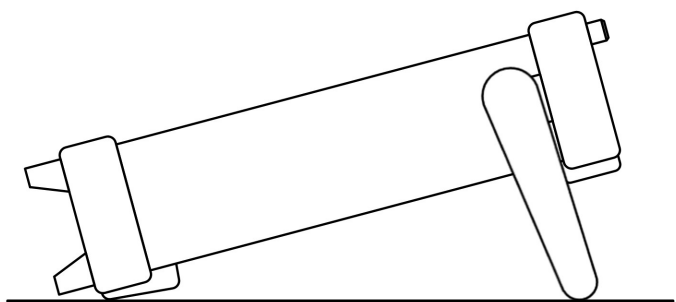
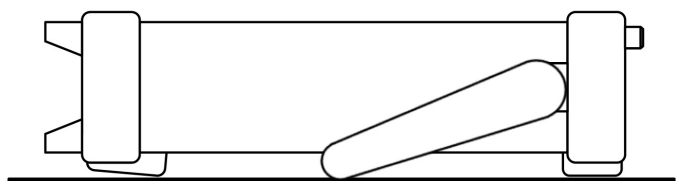

Bench-top viewing positions

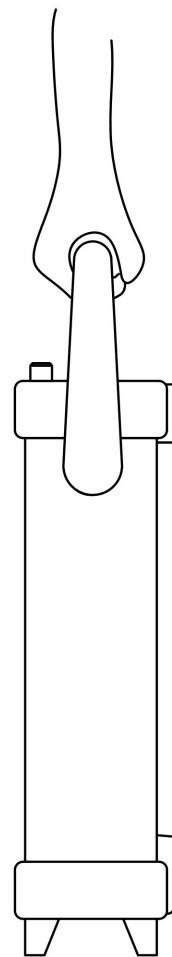

Carrying position

Rack Mounting the Instrument

You can mount the instrument in a standard 19-inch rack cabinet by ordering the rack mount kit with the part number provided as below. Instructions and mounting hardware are included with each rack-mounting kit. Any Keysight System II instrument of the same size can be rack-mounted beside the DAQ970A/DAQ973A.

CAUTION

To prevent overheating, do not block air flow to or from the instrument. Allow enough clearance at the rear, sides, and bottom of the instrument to permit adequate internal air flow.

NOTE

Remove the carrying handle, and the front and rear rubber bumpers, before rack-mounting the instrument.

Removing the handle and bumpers

To remove the handle, rotate it to the vertical position and pull the ends outward.

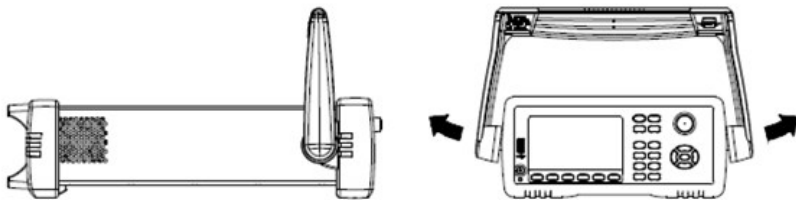

To remove the front and rear rubber bumpers, stretch a corner and then slide it off.

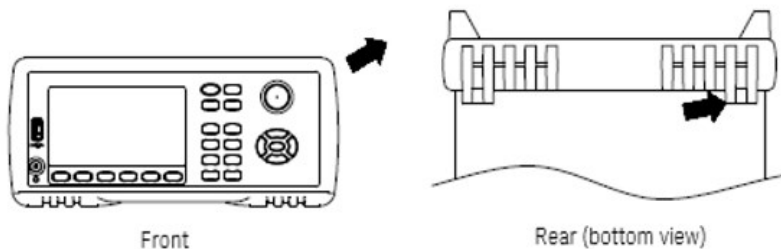

Rack mounting a single instrument

To rack mount a single instrument, order the adapter kit (part number: DAQA190A-FG or 1CM124A).

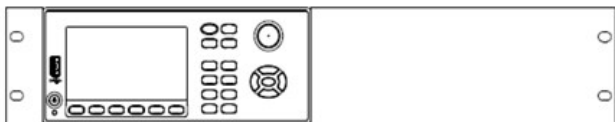

Rack mounting instruments side-by-side

To rack mount two instruments side-by-side, order the lock-link kit (part number: DAQA194A-FG or 34194A) and flange kit (part number: DAQA191A-FG or 1CM107A). Be sure to use the support rails inside the rack cabinet.

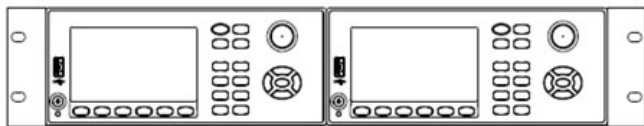

Keysight BenchVue Data Acquisition (DAQ) Software

The Keysight BenchVue Data Acquisition (DAQ) Software is a Windows-based application that makes it easy to use the instrument with your PC for gathering and analyzing measurements. Use this software to set up your test, acquire and archive measurement data, and perform real-time display and analysis results of your measurements.

The Keysight BenchVue Data Acquisition (DAQ) Software can be downloaded from

www.keysight.com/find/benchvue.

Application main screen:

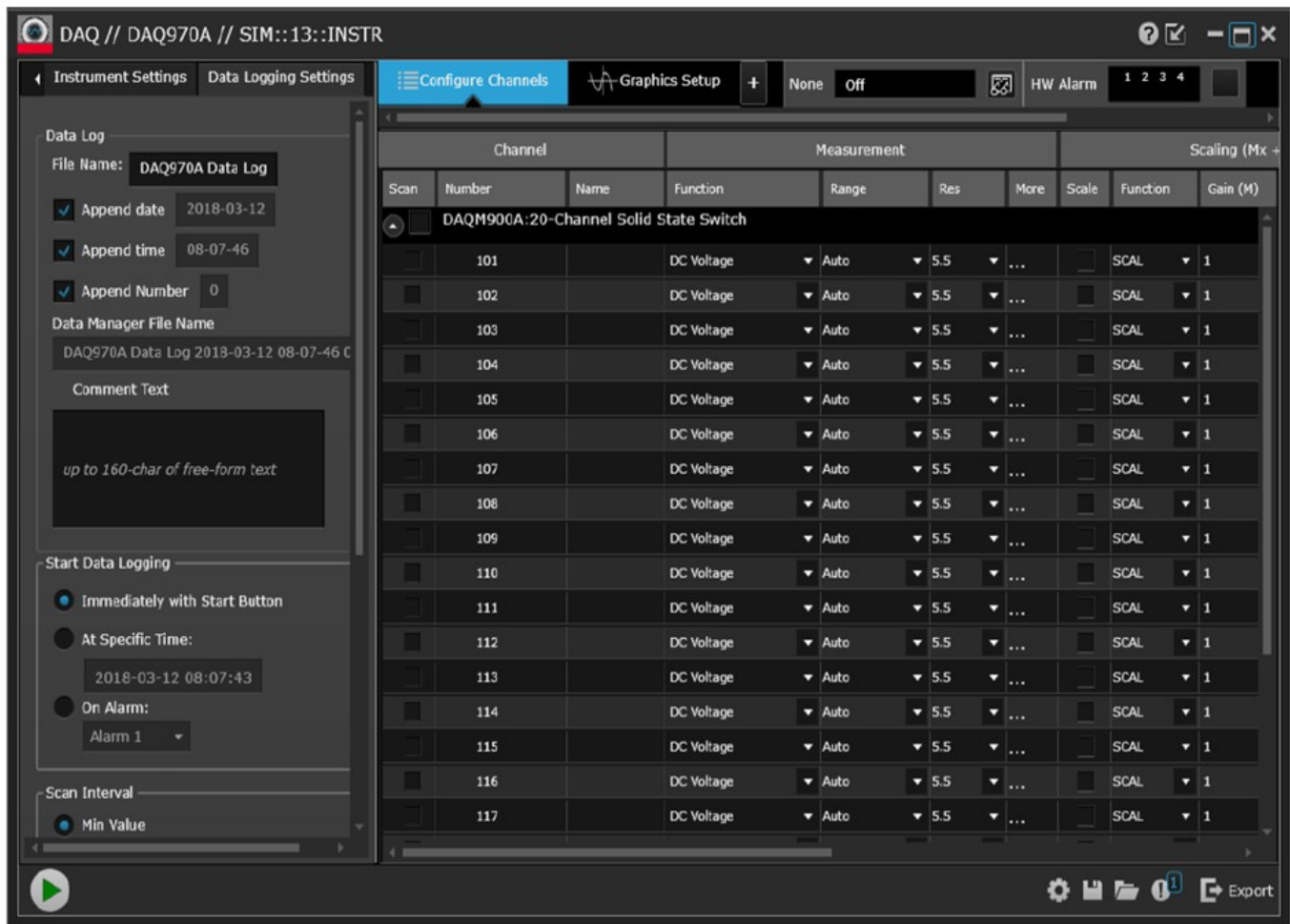

BenchVue Data Acquisition (DAQ) Software Licensing

To evaluate a BenchVue application for a free 30-day trial period, go to the BenchVue Application view, click once on the desired application, and then click on the "Start Trial" button – the trial period is based on the number of calendar days remaining. After the trial period expires, you will be required to purchase a software license for that application. Keysight's flexible licensing options allow you to select the license type and license terms that best fit your software needs. For more information on purchasing and installing a software license, see BenchVue Software Licensing Options in the Keysight BenchVue Data Acquisition (DAQ) Software Help .

3 Features and Functions

System Overview

Front Panel Menu References

[Scan/Start] Key

[Monitor] Menu

[Home] Menu

[View] Menu

[Channel] Menu

[Interval] Menu

[Math] Menu

[Copy] Menu

[Alarm] Menu

[Utility] Menu

[Module] Menu

[Save Recall] Menu

Web Interface

Module Overview

System Overview

This section provides an overview of a computer-based system and describes the parts of a data acquisition system.

- [Data Acquisition System Overview](#)
- [Signal Routing and Switching](#)
- [Measurement Input](#)
- [Control Output](#)

Data Acquisition System Overview

You can use the Keysight DAQ970A/DAQ973A as a stand-alone instrument, but there are many applications where you will want to take advantage of the built-in PC connectivity features. A typical data acquisition system is shown below:

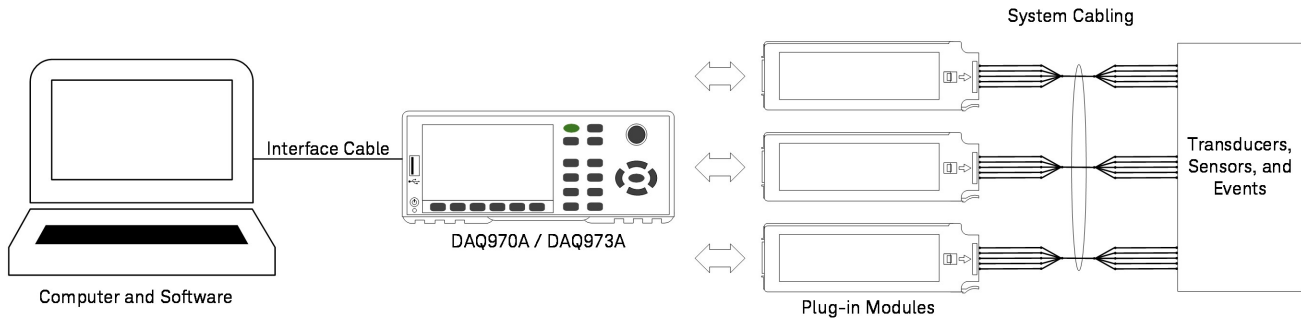

The configuration offers the following advantages:

- You can use the DAQ970A/DAQ973A to perform data storage, data reduction, mathematical calculations, and conversion to engineering units. You can use the PC to provide easy configuration and data presentation.
- You can remove the analog signals and measurement sensors from the noisy PC environment and electrically isolate them from both the PC and earth ground.
- You can get a single PC to monitor multiple instruments and measurement points while performing other PC-based tasks.

DAQ970A/DAQ973A logic circuitry

As shown below the logic circuitry for the DAQ970A/DAQ973A is divided into two sections: earth-referenced and floating. These two sections are isolated from each other in order to maintain measurement accuracy and repeatability. See [Noise caused by ground loops](#) for further details on ground loops.

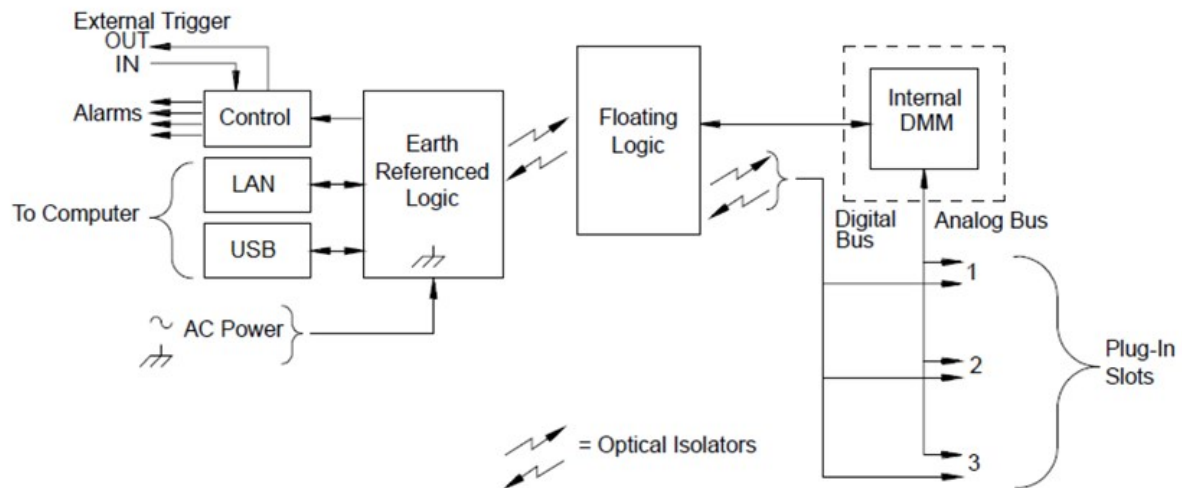

The earth-referenced and floating circuitry communicate with each other via an optically-isolated data link. The earth-referenced section communicates with the floating section to provide PC connectivity. The DAQ970A/DAQ973A is shipped with LAN and USB interfaces connectivity.

The earth-referenced section also provides four hardware alarm outputs and external trigger lines. You can use the alarm output lines to trigger external alarm lights, sirens, or send a TTL-compatible pulse to your control system.

The floating section contains the main system processor and controls all of the basic functionality of the instrument. This is where the instrument communicates with the plug-in modules, scans the keyboard, controls the front-panel display, and controls the internal DMM. The floating sections also performs measurement scaling, monitors alarm conditions, converts transducer measurements to engineering units, time stamps scanned measurements, and saves data in non-volatile memory.

Plug-in modules

The DAQ970A/DAQ973A offers a complete selection of plug-in modules to give you high-quality measurement, switching, and control capabilities. The plug-in modules communicate with the floating logic via the internal isolated digital bus. The multiplexer modules also connect to the internal DMM via the internal analog bus. Each module has its own microprocessor to offload the mainframe processor and minimize backplane communications for faster throughput. See [Module Overview](#) for more information.

Module number	Common uses
Measurement input	
DAQM900A	Scanning and direct measurement of temperature, voltage, resistance, frequency, and current (DAQM901A only) by using the internal DMM.
DAQM901A	
DAQM902A	
DAQM907A	Digital Input, Event Counting.
DAQM908A	Scanning and direct measurement of temperature, voltage, and resistance by using the internal DMM.
DAQM909A	Digitizing measurement of voltage and strain by using the on board digitizers.
Signal routing	
DAQM900A	N/A
DAQM901A	Multiplexing of signals to or from external instruments.
DAQM902A	N/A
DAQM904A	32 Crosspoint Matrix Switching.
DAQM905A	50 Ω high-frequency applications (<2 GHz).
DAQM908A	N/A
Control output	
DAQM903A	General-purpose switching and control using Form C (SPDT) switches.
DAQM907A	Digital Output, Voltage (DAC) Outputs.

System cabling

The plug-in modules have screw-terminal connectors to make it easy to connect your system cabling. The type of cabling that you use to connect your signals, transducers, and sensors to the module is critical to measurement success. Some types of transducers, such as thermocouples, have very specific requirements for the type of cable that can be used to make connections. Be sure to consider the usage environment when choosing wire gauge and insulation qualities. Wire insulation typically consists of materials such as PVC or PTFE. Table below lists several common cable types and describes their typical uses.

NOTE

Wiring insulation and usage is described in more detail in [System Cabling and Connections](#).

Cable type	Common uses	Comments
Thermocouple Extension Wire	Thermocouple measurements.	Available in specific thermocouple types. Also available in shielded cable for added noise immunity.
Twisted Pair, Shielded Twisted Pair	Measurement inputs, voltage outputs, switching, counting.	Most common cable for low-frequency measurement inputs. Twisted pair reduces common mode noise. Shielded-twisted pair provides additional noise immunity.
Shielded Coaxial, Double-Shielded Coaxial	VHF signal switching.	Most common cable for high-frequency signal routing. Available in specific impedance values (50 Ω or 75 Ω). Provides excellent noise immunity. Double-shielded cable improves isolation between channels. Requires special connectors.
Flat Ribbon, Twisted pair Ribbon	Digital Input/Output	Often used with mass termination connectors. These cables provide little noise immunity.

Transducers and sensors

Transducers and sensors convert a physical quantity into an electrical quantity. The electrical quantity is measured and the result is then converted to engineering units. For example, when measuring a thermocouple, the instrument measures a DC voltage and mathematically converts it to a corresponding temperature in $^{\circ}\text{C}$, $^{\circ}\text{F}$, or K.

Measurement	Typical transducer types	Typical transducer output
Temperature	Thermocouple	0 mV to 80 mV
	RTD	2-wire or 4-wire resistance from 5 Ω to 500 Ω
	Thermistor	2-wire resistance from 10 Ω to 1M Ω
Pressure	Solid State	± 10 DVC
Flow	Rotary Type Thermal Type	4 mA to 20 mA
Strain	Resistive Elements	4-wire resistance from 10 Ω to 10 k Ω
Events	Limit Switches Optical Counters Rotary Encoder	0 V or 5 V Pulse Train
Digital	System Status	TTL-compatible Levels

Alarm limits

The DAQ970A/DAQ973A has four alarm outputs which you can configure to alert you when a reading exceeds specified limits on a channel during a scan. You can assign a high limit, low limit, or both to any configured channel in the scan list. You can assign multiple channels to any of the four available alarms (numbered 1 through 4). For example, you can configure the instrument to generate an alarm on Alarm 1 when a limit is exceeded on any of the channels 103, 205, or 320.

You can also assign alarms to channels on the multifunction module. For example, generate an alarm when a specific bit pattern or bit pattern change is detected on a digital input channel or when a specific count is reached on a totalizer channel. With the multifunction module, the channels do not have to be part of the scan list to generate an alarm.

Signal Routing and Switching

The switching capabilities of the plug-in modules available with the DAQ970A/DAQ973A provide test system flexibility and expandability. You can use the switching plug-in modules to route signals to and from your test system or multiplex signals to the internal DMM or external instruments.

Relays are electromechanical devices which are subject to wear-out failure modes. The life of a relay, or the number of actual operations before failure, is dependent upon how it is used - applied load, switching frequency, and environment. The DAQ970A/DAQ973A relay maintenance system automatically counts the cycles of each relay in the instrument and stores the total count in non-volatile memory on each switch module. Use this feature to track relay failures and to predict system maintenance requirements.

Switching topologies

Several switching plug-in modules are available with different topologies for various applications:

Switching topologies	Plug-in modules
Multiplexer	DAQM900A, DAQM901A, DAQM902A, DAQM905A, DAQM908A
Matrix	DAQM904A
Form C (single pole, double throw)	DAQM903A

The following sections describe each of these switching topologies.

Multiplexer switching

Multiplexers allow you to connect one of multiple channels to a common channel, one at a time. A simple 4-to-1 multiplexer is shown below. When you combine a multiplexer with a measurement device, like the internal DMM, you create a scanner. For more information on scanning, see [Scanning](#).

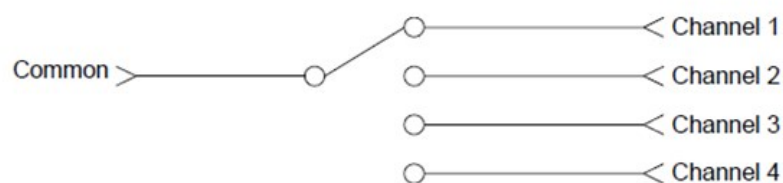

Multiplexers are available in several types:

Multiplexer type	Common use
One-wire (single-ended)	For common LO measurements. For more information, see One-wire (single-ended) multiplexers .
Two-wire	For floating measurements. For more information, see Two-wire multiplexers .
Four-wire	For resistance and RTD measurements. For more information, see Four-wire multiplexers .
RF Signal	Very High Frequency (VHF) for switching frequencies up to 2.8 GHz. For more information, see RF Signal Multiplexing .

Matrix switching

A matrix switch connects multiple inputs to multiple outputs and therefore offers more switching flexibility than a multiplexer. Use a matrix for switching low-frequency (less than 10 MHz) signals only. A matrix is arranged in rows and columns. For example, a simple 3×3 matrix could be used to connect three sources to three test points as shown below:

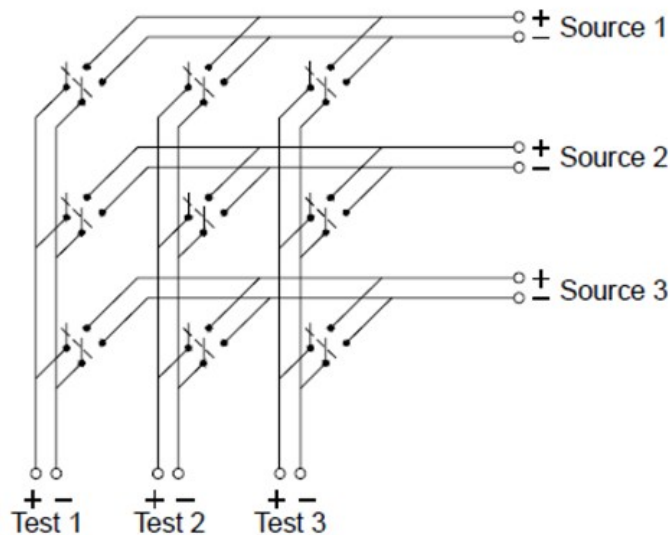

Any one of the signal sources can be connected to any one of the test inputs. Be aware that with a matrix, it is possible to make sure that dangerous or unwanted conditions are not created by these connections.

Form C (SPDT) switching

The DAQM903A contains 20 Form C switches (also called single-pole, double-throw). You can use Form C switches to route signals but they are typically used to control external devices.

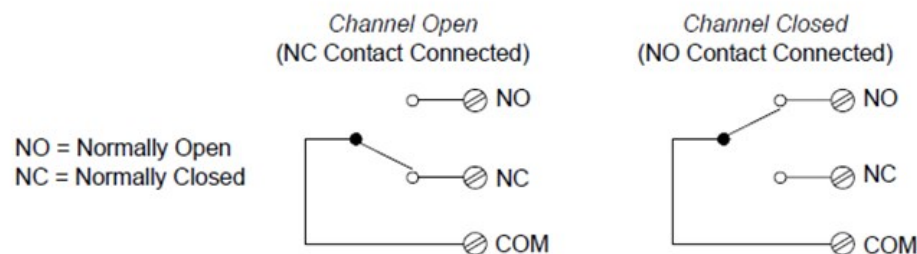

Measurement Input

The DAQ970A/DAQ973A allows you to combine a DMM (either internal or external) with multiplexer channels to create a scan. During a scan, the instrument connects the DMM to the configured multiplexer channels one at a time and makes a measurement on each channel.

Any channel that can be "read" by the instrument can also be included in a scan. This includes any combination of temperature, voltage, resistance, current, frequency, or period measurements on multiplexer channels. A scan can also include a read of a digital port, a read via the sense channel, or a read of the totalizer count on the multifunction module.

The internal DMM

A transducer or sensor converts a physical quantity being measured into an electrical signal which can be measured by the internal DMM. To make these measurements, the internal DMM incorporates the following functions:

- Temperature (thermocouple, RTD, and thermistor)
- Voltage (DC and AC up to 300 V)
- Resistance (2-wire and 4-wire up to 1G Ω)
- Current (DC and AC up to 1 A)
- Frequency and Period (up to 300 kHz)

The internal DMM provides a universal input front-end for measuring a variety of transducer types without the need for additional external signal conditioning. The internal DMM includes signal conditioning, amplification (or attenuation), and a high resolution (up to 22 bits) analog-to-digital converter. A simplified diagram of the internal DMM is shown below:

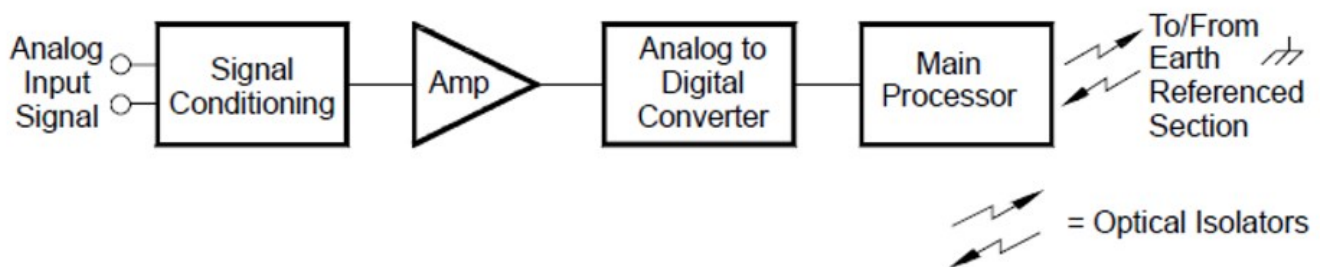

Signal conditioning, ranging, and amplification

Analog input signals are multiplexed into the internal DMM's signal-conditioning section – typically comprising switching, ranging, and amplification circuitry. If the input signal is a DC voltage, the signal conditioner is composed of an attenuator for the higher input voltages and a DC amplifier for the lower input voltages. If the input signal is an AC voltage, a converter is used to convert the AC signal to its equivalent DC value (true RMS value). Resistance measurements are performed by supplying a known DC current to an unknown resistance and measuring the DC voltage drop across the resistor. The input signal switching and ranging circuitry, together with the amplifier circuitry, convert the input to a DC voltage which is within the measuring range of the internal DMM's analog-to-digital converter (ADC).

You can allow the instrument to automatically select the measurement range using autoranging or you can select a fixed measurement range using manual ranging. Autoranging is convenient because the instrument automatically selects the range to use for each measurement based on the input signal. For fastest scanning operation, use manual ranging for each measurement (some additional time is required for autoranging since the instrument has to make a range selection).

Analog-to-digital conversion (ADC)

The ADC takes a prescaled DC voltage from the signal-conditioning circuitry and converts it to digital data for output and display on the front panel. The ADC governs some of the most basic measurement characteristics. These include measurement resolution, reading speed, and the ability to reject spurious noise. There are several analog-to-digital conversion techniques but they can be divided into two types: integrating and non-integrating. The integrating techniques measure the average input value over a defined time interval, thus rejecting many noise sources. The non-integrating techniques sample the instantaneous value of the input, plus noise, during a very short interval. The internal DMM uses an integrating ADC technique.

Main processor

The main processor, located in the floating logic section, controls the input signal conditioning, ranging, and the ADC. The main processor accepts commands from, and sends measurement results to, the earth referenced logic section. The main processor synchronizes measurements during scanning and control operations. The main processor uses a multi-tasking operation system to manage the various system resources and demands.

The main processor also calibrates measurement results, performs $Mx+B$ scaling, monitors alarm conditions, converts transducer measurements to engineering units, time stamps scanned measurements, and stores data in non-volatile memory.

Scanning

The instrument allows you to combine a DMM (either internal or external) with multiplexer channels to create a scan. During a scan, the instrument connects the DMM to the configured multiplexer channels one at a time and makes a measurement on each channel.

Before you can initiate a scan, you must set up a scan list to include all desired multiplexer or digital channels. Channels which are not in the scan list are skipped from the scan. The instrument automatically scans the list of channels in ascending order from slot 1 through slot 3. Measurements are taken only during a scan and only on those channels which are included in the scan list.

You can store up to 1,000,000 readings in non-volatile memory during a scan. Readings are stored only during a scan and all readings are automatically time stamped. Each time you start a new scan, the instrument clears all readings stored in memory from the previous scan. Therefore, all readings currently stored in memory are from the most recent scan.

You can configure the event or action that controls the onset of each sweep through the scan list (a sweep is one pass through the scan list):

- You can set the instrument's internal timer to automatically scan at a specific interval as shown below. You can also program a time delay between channels in the scan list.

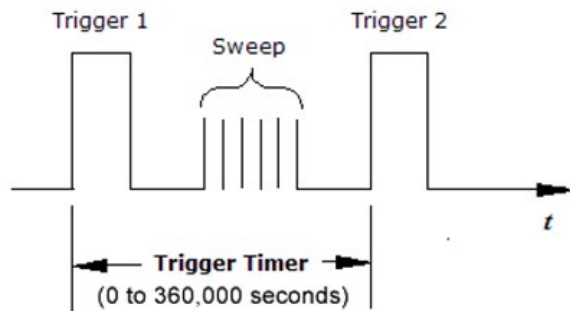

- You can manually control a scan by repeatedly pressing [**Scan/Start**] key from the front panel.
- You can start a scan by sending a software command from the remote interface.
- You can start a scan when an external TTL-compatible trigger pulse is received.
- You can start a scan when an alarm condition is logged on the channel being monitored.

Scanning with External Instruments

You can use the DAQ970A/DAQ973A for signal routing or control applications. If you install a multiplexer plug-in module, you can use the DAQ970A/DAQ973A for scanning with an external instrument. You can connect an external instrument (such as a DMM) to the multiplexer COM terminal.

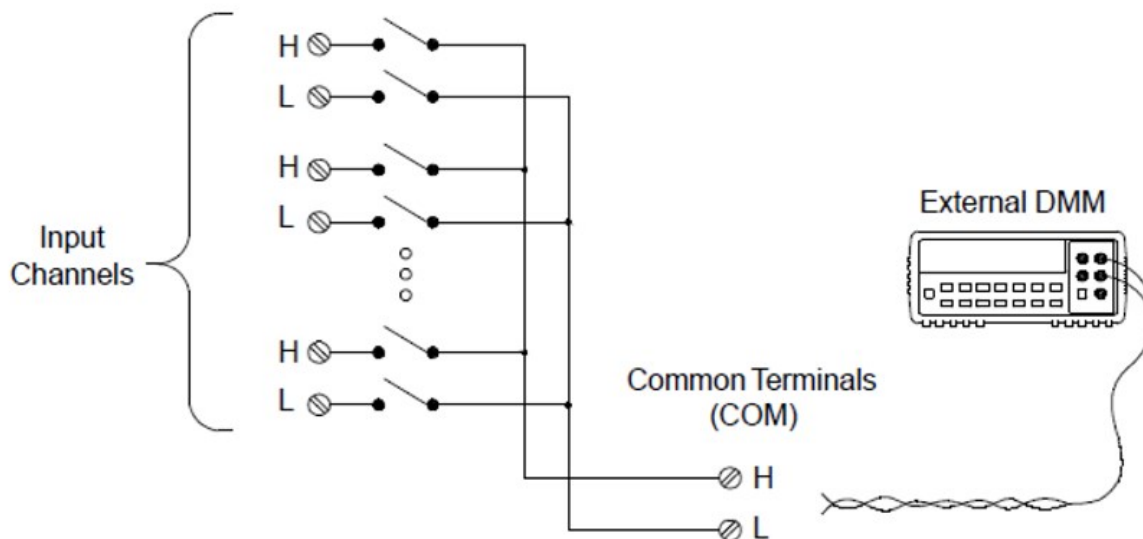

To control scanning with an external instrument, two control lines are provided. When the DAQ970A/DAQ973A and the external instrument are properly configured, you can synchronize a scan sequence between the two.

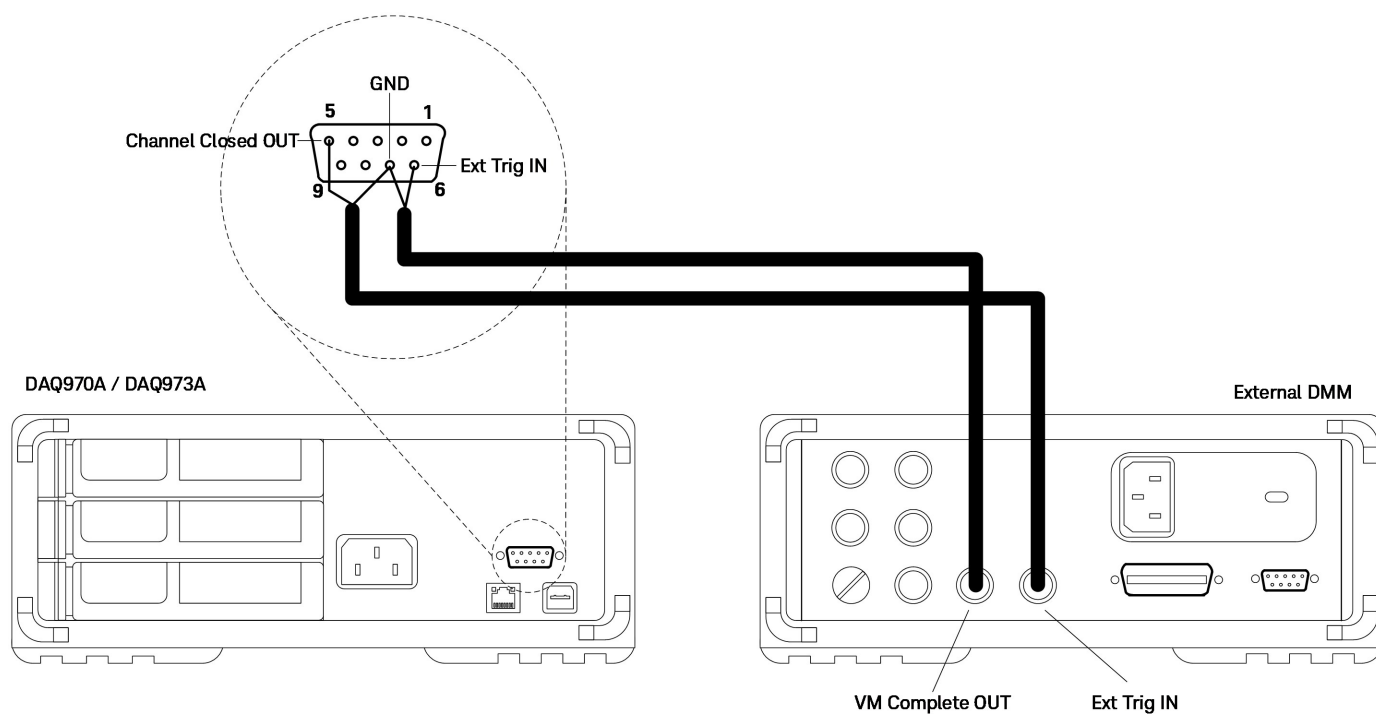

The Multifunction Module

The multifunction module (DAQM907A) adds two additional measurement input capabilities to the system: digital input and event totalize.

The multifunction module also contains a dual voltage output (DAC). For more details, see [Transducers and sensors](#).

Digital input

The multifunction module has two non-isolated 8-bit input/output ports which you can use for reading digital patterns. You can read the live status of the bits on the port or you can configure a scan to include a digital read. Each port has a separate channel number on the module and contains 8-bits. You can combine the two ports to read a 16-bit word.

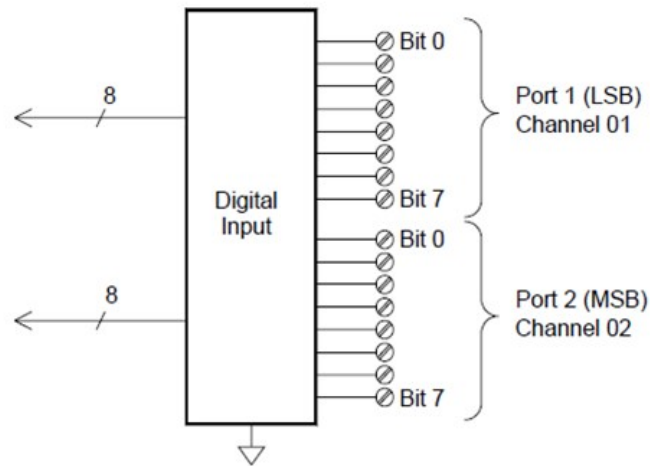

Totalizer

The multifunction module has a 26-bit totalizer which can count pulses at a 100 kHz rate. You can manually read the totalizer count or you can configure a scan to read the count.

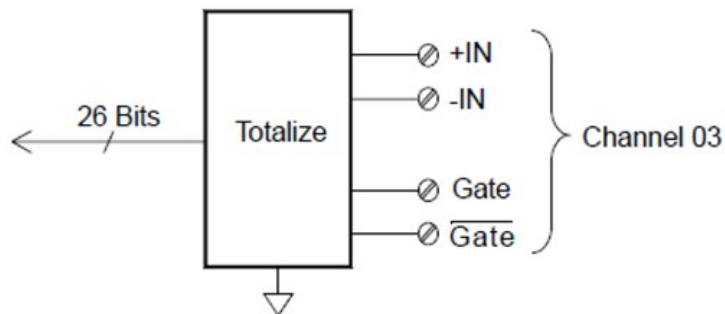

You can configure the totalizer to count on the rising edge or falling edge of the input signal. The maximum count is 67,108,863 ($2^{26}-1$). The count rolls over to "0" after reaching the maximum allowed value. You can configure the totalizer to read without affecting the count or reset the count to zero without losing any counts.

Control Output

In addition to signal routing and measurement, you can also use the DAQ970A/DAQ973A to provide simple control outputs. For example, you can control external high-power relays using the actuator module or a digital output channel.

The multifunction module

The multifunction module (DAQM907A) adds two additional control output capabilities to the system: digital output and voltage (DAC) output.

The multifunction module also contains digital input and event totalizer capabilities. For more details, see [The Multifunction Module](#).

Digital output

The multifunction module has two non-isolated 8-bit input / output ports which you can use to output digital patterns. Each port has a separate channel number on the module and contains 8-bits. You can combine the two ports to output a 16-bit word.

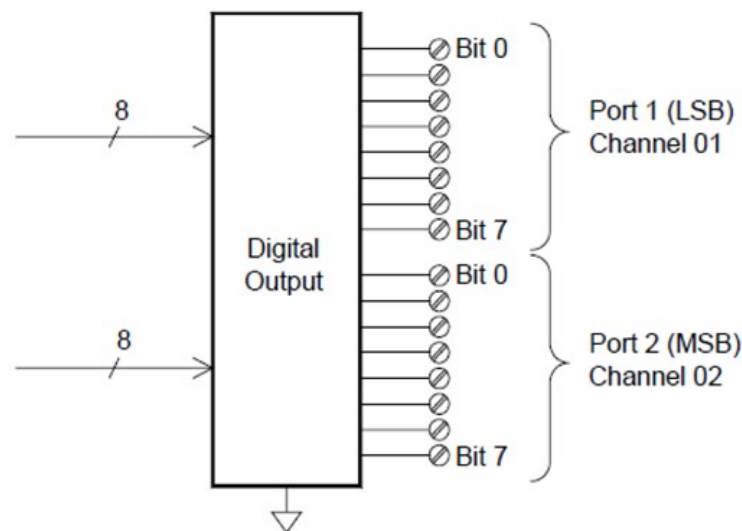

Voltage (DAC) output

The multifunction module has two analog outputs capable of outputting calibrated voltages between ± 12 V with 18 bits of resolution. Each DAC (Digital-to-Analog Converter) channel can be used as a programmable voltage source for analog input control of other devices. A simplified diagram is shown below:

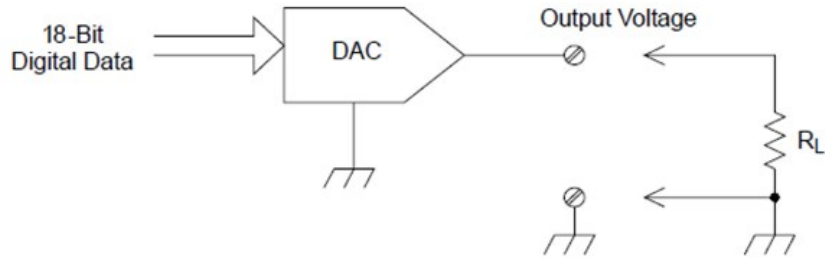

You can set the output voltage to any value between ± 12 VDC, in $100 \mu\text{V}$ steps. Each DAC is earth referenced, it cannot float. Each DAC channel is capable of supplying 15 mA maximum current during output voltage mode. Or you can set the DAC to constant current mode, to output any current between ± 24 mA, in $0.2 \mu\text{A}$ steps.

Each DAC channel is capable of supplying 24 mA maximum current.

NOTE You must limit the output current to 40 mA for each slot (two DAC channels).

The actuator/general purpose switch

You can think of the DAQM903A Actuator as a control output because it is often used to control external power devices. The actuator provides 20 independent, isolated Form C (SPDT) switches.

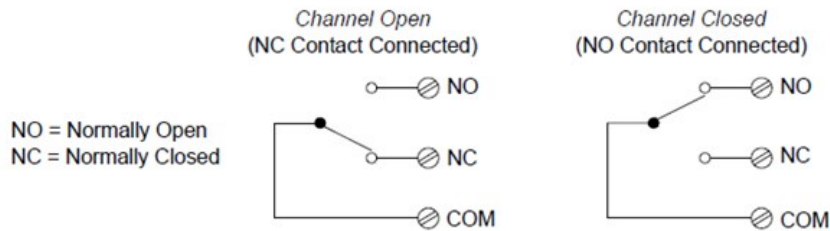

Each channel can switch up to 300 V DC or AC rms. Each switch can also switch up to 1 A DC or AC rms up to maximum 50 W. For example, the maximum current that you can switch at 120 V is 0.45 A as shown below:

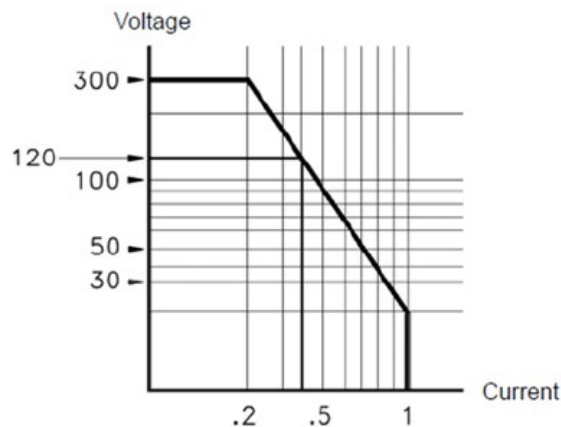

For control applications, the actuator has the following advantages:





Higher voltage and power rating than the digital output channels. The actuator switches can also be used to control power devices.

When used with high-power devices, however, it is critical that you provide protection to the switch from capacitive and inductive loads to ensure maximum relay life.

For more information on attenuators, see [Using Attenuators](#).

Front Panel Menu References

Table below summarizes the front panel keys and the menu structure.

Key	Description
	<ul style="list-style-type: none"> – Initiates/stops a scan/digitize process, or performs a single sweep in manual trigger mode. – Press once to initiate a scan/digitize; press and hold to stop the operation. – The key's backlight is turned on while scanning/digitizing is in progress. – In DMM Digitize, and Digitizer data acquisition mode, the key's backlight is also turned on while auto save is in progress – In Scan data acquisition mode, the instrument automatically scans the configured channels in consecutive order from slot 1 through slot 3. Channels that are not configured are skipped. – In DMM Digitize data acquisition mode, the instrument automatically starts the DMM digitizing operation on a single configured channel. – In Digitizer data acquisition mode (only supported on the DAQM909A plug-in module), the instrument automatically starts the digitizing operation for all the configured channels simultaneously.
	<ul style="list-style-type: none"> – Monitors a channel's measurement data that is useful for troubleshooting the instrument and observing an important signal. – You can select to view the monitor measurements in number, bar meter, trend chart, and histogram format. – The key's backlight is turned on while monitoring is enabled. The monitor annunciator will also be displayed, and the sample annunciator will flash when monitoring is made. In the event the Digitizer data acquisition mode is enabled, the key's backlight will be turned off but the annunciator will continue to be displayed on screen indicating that the monitor operation is still running in the background. – To stop the monitoring mode and return to Home menu page, press this key again on the Monitor menu page.
	<ul style="list-style-type: none"> – Brings up the Home page that displays the instrument information and a list of help topics the in selected local language. – Selects the data acquisition mode to be used (Scan, DMM Digitize, or Digitizer). – Measures the offset on strain channels. – Configures the four alarm output hardware lines. – Configures various user preferences.
	<ul style="list-style-type: none"> – Views scanned memory readings. – View digitized readings. – Views alarm queue. – Views error queue. – Performs and views power analysis.

-
- Channel labeling.
 - Closes or opens switches on switching channels.
 - Selects measurement function.
 - Selects measurement range or autorange.
 - Selects the integration time.
 - Configures advanced measurement features.
-

- Configures what starts each sweep, or the interval between sweeps, and the number of sweeps during the scan.
 - Configures the sample timer, sample count and trigger settings for the digitizer.
-

Math

- Configures the measurement scaling ($mX+b$, %, dBm, or dB) on the current channel.
-

Copy

- Copies the measurement configuration from the selected channel(s) to other channel(s).
-

Alarm

- Configures alarm on the selected channel. There are four configurable alarms in this instrument.
-

Utility

- Self-test.
 - Calibration.
 - Autocalibration. Instrument security (NISPOM).
 - Firmware update.
-

- Overview of the scan list for the module.
 - Performs a module reset.
 - Module labeling.
 - Views information on the internal DMM.
 - Views information on modules' relay cycle.
-

- Saves and recalls instrument state files (.sta extension) and preference files (.prf extension).
 - File management.
 - Saves the readings from trend chart or histogram.
 - Captures and saves the screen image.
 - Instrument factory reset and system preset.
 - Data logging to a USB drive on the front panel.
 - Auto save digitizer data to a USB drive on the front panel.
 - Returns the instrument into local control when the instrument is in remote.
-

[Scan/Start] Key

Press the **[Scan/Start]** key on the front panel to initiate any scanning or digitizing operations, or to perform a single sweep/record when operating in manual trigger mode. See the **[Interval] Menu** for more information on how the **[Scan/Start]** key is used when the manual trigger mode is selected.

The **[Scan/Start]** key's backlight is turned on while scanning/digitizing is in progress. To stop the scan or digitizer operation, press and hold the **[Scan/Start]** key for more than 2 seconds. In Scan data acquisition mode, "Scan stopped" is shown when the operation is terminated. Likewise, in DMM Digitize and Digitizer data acquisition mode, "DMM Digitize stopped" and "Digitizer stopped" will be shown respectively when the operation is terminated.

NOTE

When the Auto Save feature in the **[Save Recall]** menu is turned on for DMM Digitize/Digitizer data acquisition mode, the digitizing operation will not begin unless the instrument detects a USB drive connected to the USB port at the front panel.

[Monitor] Menu

NOTE

The [Monitor] menu features are not available for **Digitizer** data acquisition mode.

In **Scan/DMM Digitize** mode, you can monitor the measurement data on a selected channel by pressing the **[Monitor]** key. The key's backlight is turned on while monitoring is enabled. The monitor annunciator will also be displayed, and the sample annunciator will flash when monitor measurements are made.

In **Scan** mode, you can view the monitor data for all channels, except for computed channels (channels 401 through 420). Monitoring of computed channels is only available while scanning and will only display the reading from the most recent sweep. You can also view monitor data on the DAQM907A digital I/O and totalizer channels even if they are not in the scan list.

Monitor measurements are made repetitively when scanning is idle or between sweeps of a scan. To stop the monitoring mode and return to the Home menu page, press the **[Monitor]** key again on the Monitor menu page.

In **DMM Digitize** mode, you can only view the monitoring data of the single channel that is configured for **DMM Digitize**. The data will only be displayed as a number and its related Minimum, Maximum, and Peak to Peak data if the **Peak On/Off** softkey is toggled to **On**.

However in **Scan** mode, you may choose to display the monitoring data in the following formats: **Number**, **Bar Meter**, **Trend Chart**, or **Histogram**. To configure, press **Display** softkey to select your desired display mode. The example of the softkeys is shown below.

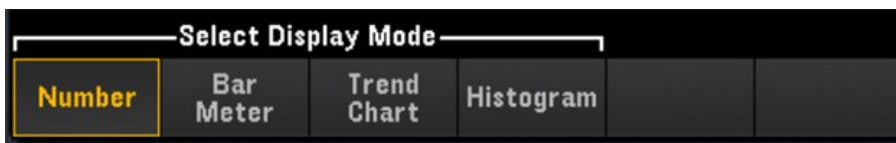

Number

Displays readings as a number



Softkey	Description
Peak On/Off	Press the Peak softkey to toggle between enabling (On) or disabling (Off) the measurement of the Minimum, Maximum, and Peak to Peak values acquired within the measurement aperture.
Clear Peaks	Press the Clear Peaks softkey to reset the reading of peak values. This is done by clearing the accumulated history of peak-to-peak function.
	NOTE The Clear Peaks softkey will only be displayed when Peak is set to On.
Clear Mon Data	Press the Clear Mon Data softkey to clear the statistics, trend chart, and histogram on the monitor channel.
	NOTE The Clear Mon Data softkey will only be displayed when Statistics is set to Show.
Statistics Hide/Show	Press the Statistics softkey to toggle between Hide or Show the measurement statistics for the monitor channel. Monitor channel statistics are cleared when monitor mode is turned on, when the monitor channel changes, or when the monitor channel's configuration is changed.

Bar Meter

The bar meter adds a moving bar below the standard Number display.

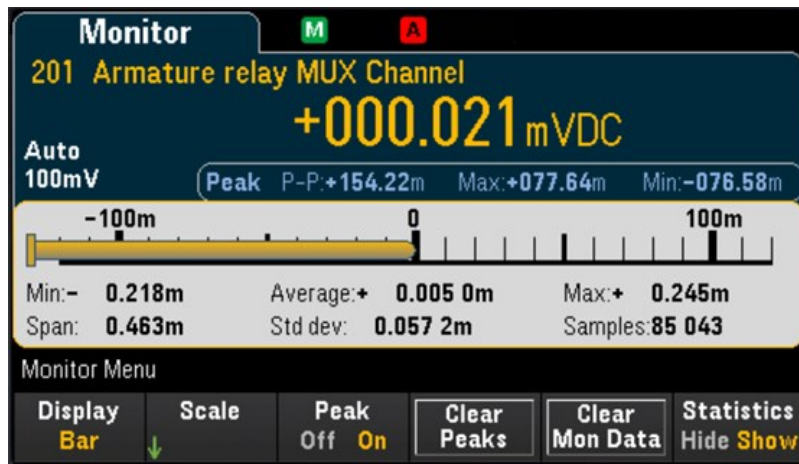

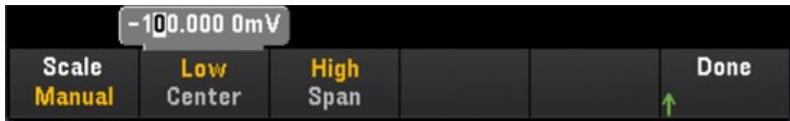
Softkey	Description
Scale	<p>Default sets the scale to the measurement range.</p>
	<p>Manual</p>  <p>Manual allows you to configure the scale either as High and Low values or as a Span around a Center value. For example, a scale that goes from a Low of $-500\ \Omega$ to a High of $1000\ \Omega$ could also be specified as a Center of $250\ \Omega$ with a Span of $1500\ \Omega$.</p>
	<p>Limits set the scale to the alarm limits.</p> <p>NOTE This softkey is only available when you configure alarm on the selected channel by pressing the [Alarm] key on the front panel.</p>
Peak On/Off	<p>Press the Peak softkey to toggle between enabling (On) or disabling (Off) the measurement of the Minimum, Maximum, and Peak to Peak values acquired within the measurement aperture.</p>
Clear Peaks	<p>Press the Clear Peaks softkey to reset the reading of peak values. This is done by clearing the accumulated history of peak-to-peak function.</p> <p>NOTE The Clear Peaks softkey will only be displayed when Peak is set to On.</p>
Clear Mon Data	<p>Press the Clear Mon Data softkey to clear the statistics, trend chart, and histogram on the monitor channel.</p> <p>NOTE The Clear Mon Data softkey will only be displayed when Statistics is set to Show.</p>
Statistics Hide/Show	<p>Press the Statistics softkey to toggle between Hide or Show the measurement statistics for the monitor channel. Monitor channel statistics are cleared when monitor mode is turned on, when the monitor channel changes, or when the monitor channel's configuration is changed.</p>

Trend Chart

In the Continuous measurement mode, the trend chart shows data trends over time. Data is collected and displayed in pixel columns as described below:

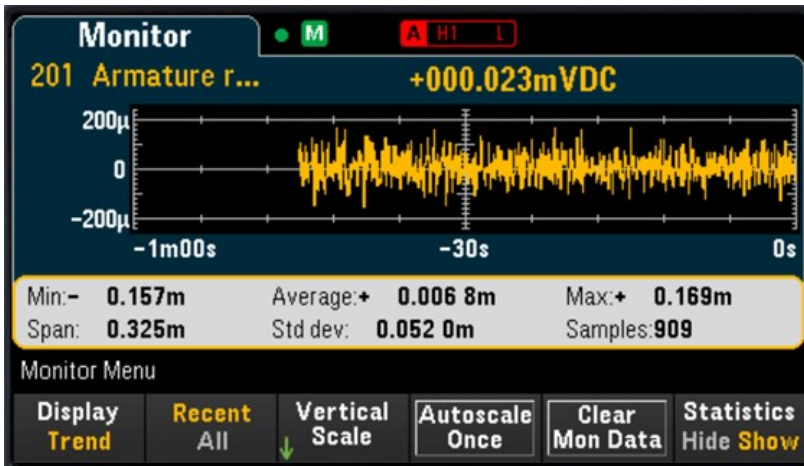

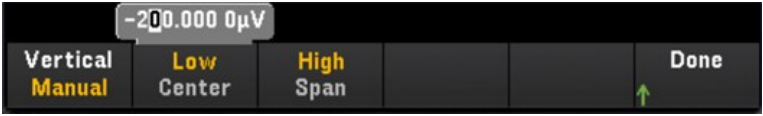
Softkey		Description
Recent/All		The Recent/All softkey specifies whether all measurements (All) or only the most recent measurements (Recent) are shown on the trend chart. Neither selection clears reading memory. In All mode, the trend chart displays all readings being taken and builds from left to right. After the display is filled, the data becomes compressed on the left side of the display as new data is added on the right side of the display. In Recent mode, the trend chart displays data taken during a specified amount of time.
Vertical Scale	Default	Default sets the scale to the measurement range.
	Auto	Auto automatically adjusts the scale to appropriately fit the line currently shown on the screen.
	Manual	 <p>Manual allows you to configure the scale either as High and Low values or as a Span around a Center value. For example, a scale from a Low of 0 V to a High of 5 V is equivalent to a Center of 2.5 V and a Span of 5 V.</p>
Limits	Limits set the scale to the alarm limits.	
		<div style="border: 1px solid black; padding: 5px; display: inline-block;">NOTE</div> This softkey is only available when you configure alarm on the selected channel by pressing the [Alarm] key on the front panel.
Autoscale Once		Press Autoscale Once softkey to automatically scale the trend chart's vertical axis one time based on the scanned memory readings shown on the screen. This also sets the Vertical Scale mode to Manual .
Clear Mon Data		Press the Clear Mon Data softkey to clear the statistics, trend chart, and histogram on the monitor channel.
		<div style="border: 1px solid black; padding: 5px; display: inline-block;">NOTE</div> The Clear Mon Data softkey will only be displayed when Statistics is set to Show .
Statistics Hide/Show		Press the Statistics softkey to toggle between Hide or Show the measurement statistics for the monitor channel. Monitor channel statistics are cleared when monitor mode is turned on, when the monitor channel changes, or when the monitor channel's configuration is changed.

Histogram

The histogram shows measurement data as a graphical representation of the distribution of measurement data. Data is grouped in bins represented by vertical bars in the histogram display.

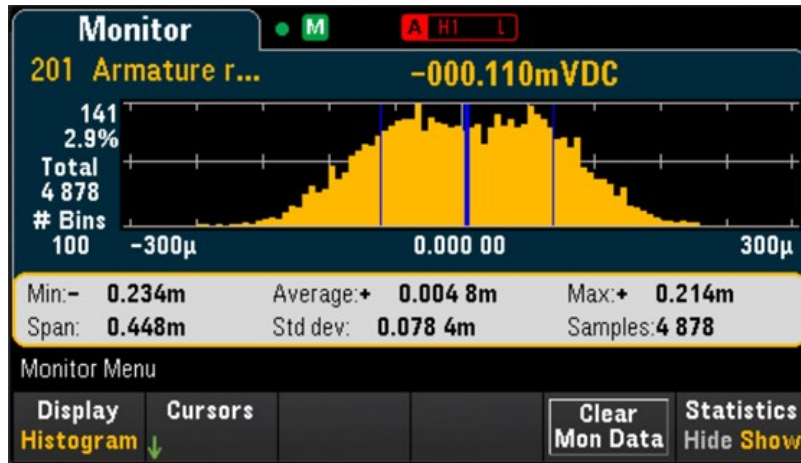

Softkey	Description
Cursors	Press the Cursors softkey to toggle between enabling (On) or disabling (Off) the histogram's cursors
B1	Use the knob or arrow keys to adjust the position of cursor B1 (Violet dotted vertical line).
B2	Use the knob or arrow keys to adjust the position of cursor B2 (Green dotted vertical line).
Clear Mon Data	Press the Clear Mon Data softkey to clear the statistics, trend chart, and histogram on the monitor channel.
<div style="background-color: #cccccc; padding: 5px; display: inline-block;">NOTE</div> The Clear Mon Data softkey will only be displayed when Statistics is set to Show.	
Statistics Hide/Show	Press the Statistics softkey to toggle between Hide or Show the measurement statistics for the monitor channel. Monitor channel statistics are cleared when monitor mode is turned on, when the monitor channel changes, or when the monitor channel's configuration is changed.

Cursors in the histogram are specified as bin numbers and display the range of values covered by those bins, the count and the percentage of the total. The total count and percentage of total, as well as the measurement range covered, between the cursor bins, are also displayed.

In the example below, cursor B1 (violet vertical lines) is positioned on bin number 30 and cursor B2 (green vertical lines) is positioned on bin number 50 (bin number shown above the B2 softkey). The bin information for cursor B1 is shown in the violet box and the bin information for cursor B2 is shown in the green box.

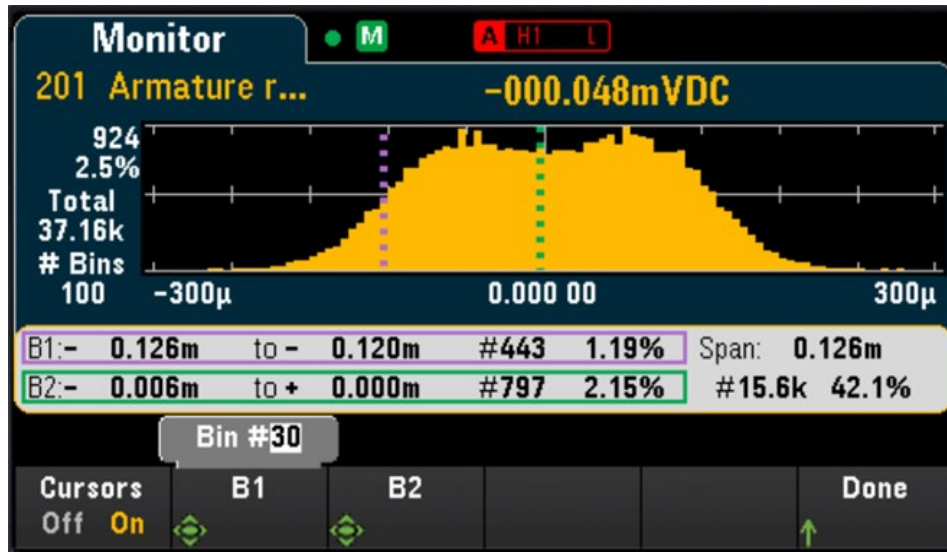

Based on the example above, the information for cursor B1 can be interpreted as follows:

- 0.126m to 0.120m - Range of DCV measurement values for this bin.
- #443 - Number of samples in this bin.
- 1.19% - Percentage of the total number of samples in this bin.

The data between the B1 and B2 cursors, including the data in the B1 and B2 bins, is shown to the right of the violet and green boxes. In the graphic above:

- Span: 0.126m - The measurement range covered from B1 to B2.
- #15.6k - The number of samples from B1 to B2.
- 42.1% - The percentage of the total number of samples from B1 to B2.

[Home] Menu

Press the **[Home]** key to access the instrument's **Home** page. On the **Home** page, an overview of the instrument's current status and operation will be displayed on the main screen. In the **Home** menu, you will also be able to access the instrument's help topics here and configure various settings such as the instrument's acquire mode, strain offset, alarm output hardware lines, and user's preferences.

NOTE

The instrument will return to the Home menu page when monitoring mode is stopped.



Data acquisition mode

Press the **Acquire** softkey to select a data acquisition mode.

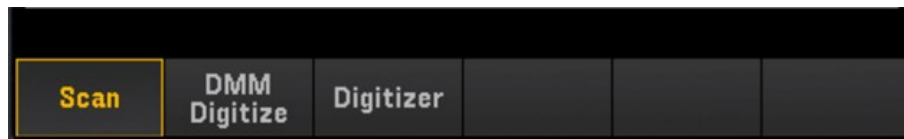

Softkey	Description	
Acquire	Scan	The instrument continuously scans through all configured channels and performs measurements.
	DMM Digitize	The instrument digitizes the signals of a single configured channel using the internal DMM.
	Digitizer	The instrument digitizes up to 4 configured digitizer channels simultaneously for each DAQM909A plug-in module inserted in the instrument using the DAQM909A's onboard digitizers. In other words, a maximum of 12 configured channels can be digitize simultaneously when the DAQ970A/DAQ973A is installed with 3 DAQM909A plug-in modules. It can also operate in parallel to a Scan or DMM Digitize data acquisition operation as it utilizes the DAQM909A's onboard digitizers instead of the instrument's internal DMM.

NOTE

The **Digitizer** softkey will only be available when the DAQM909A module is inserted into the mainframe.

Strain offset

NOTE

This softkey is only available after you configured the channel for strain measurements by pressing **[Channel]** > **Measure**, and select **STRAIN** with DAQM900A, DAQM901A, DAQM902A, DAQM908A, and DAQM909A modules. See **Strain** for details.



Strain offset is also known as the unstrained value. You can select one or more channels on which you want to measure the offset value. The strain formula will automatically use this offset value when calculating the measurement result.



To configure the strain offset:

1. Use the knob or the front panel arrow keys to navigate across the list and press the **Select** softkey to enable the strain offset measurement on the highlighted channel. The selected channel is marked with an "X". Press the **Select** softkey again to disable the offset measurement on the highlighted channel. Note that upon pressing this softkey will also enable the **Measure Now** and **Clear Offsets** softkeys.

Unstrained			
Check	Channel	Offset	Units
[x]	101 Armature relay MUX Channel	+0.0000	mVDC
	102 Armature relay MUX Channel	+0.0000	mVDC
[x]	103 Armature relay MUX Channel	+0.0000	mVDC
	104 Armature relay MUX Channel	+0.0000	mVDC

2. Press **Select All** to enable the offset measurement on all listed channels. Press this softkey again to disable the offset measurement on all listed channels.

Unstrained			
Check	Channel	Offset	Units
[x]	101 Armature relay MUX Channel	+0.0000	mVDC
[x]	102 Armature relay MUX Channel	+0.0000	mVDC
[x]	103 Armature relay MUX Channel	+0.0000	mVDC
[x]	104 Armature relay MUX Channel	+0.0000	mVDC

3. Press **Measure Now** to immediately measures the offset value on the selected channel(s). Offset readings will display on the screen as shown below:

Unstrained			
Check	Channel	Offset	Units
[x]	101 Armature relay MUX Channel	+827.0444	mVDC
[x]	102 Armature relay MUX Channel	+826.7458	mVDC
[x]	103 Armature relay MUX Channel	+825.8469	mVDC
[x]	104 Armature relay MUX Channel	+822.6777	mVDC

4. Press **Clear Offsets** softkey if you would like to immediately clear the strain offset value to 0 on the selected channel(s).

Alarm output

Configures the four alarm output hardware lines. Four TTL-compatible alarm outputs are available on the rear panel Ext Trig/Alarms connector. You can use these hardware outputs to trigger external alarm lights, sirens, or send a TTL-compatible pulse to your control system. You can assign an alarm to any configured channel and multiple channels can be assigned to the same alarm number. Each alarm output line represents the logical "OR" of all channels assigned to that alarm number (an alarm on any of the associated channels will pulse the line).

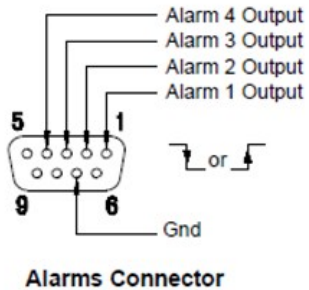

Press the **Alarm Out** softkey to configure the output alarm.

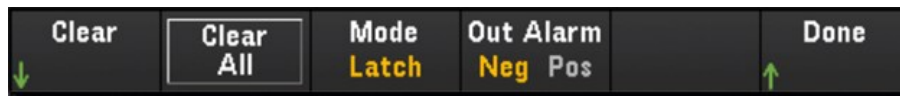

Softkey		Description
Clear	Alarm 1	Clears the state of a specified alarm output line (Alarms 1 through 4).
	Alarm 2	
	Alarm 3	
	Alarm 4	
Clear All		Clears the state of all four alarm output lines.
Mode	Latch	The alarm output is asserted when a channel's reading crosses a limit, and remains asserted until you clear it manually, start a new scan, or cycle power.
	Track	The alarm output is asserted when a channel's reading crosses a limit, and remains asserted only while subsequent readings remain outside the limit. When a reading returns within the limits, the output is automatically cleared.
Out Alarm	Neg	Configures the level for all four alarm output lines to indicate an alarm at 0 V (TTL-compatible low).
	Pos	Configures the level for all four alarm output lines to indicate an alarm at 3.3 V (TTL-compatible high).

Help topics

Displays the instrument information and a list of help topics in the selected local language. See [Use the Built-In Help System](#) for details.

User settings

Configures user preferences that control how the user interacts with the instrument. These settings are saved in non-volatile memory and can be saved in a preferences (.prf) file.

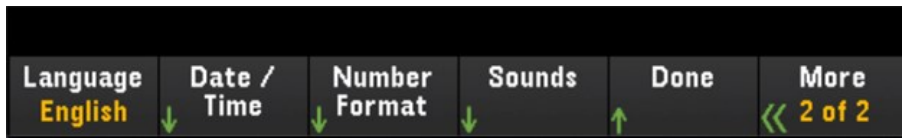
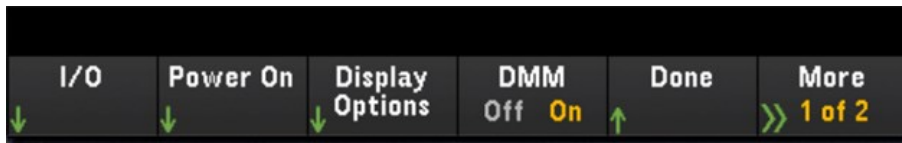

I/O

Configures the I/O parameters for remote operations over the LAN and USB interfaces.

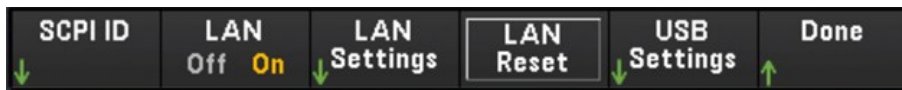

Softkey	Description
SCPI ID	<p>SCPI ID determines the manufacturer and model number returned by identification query (*IDN? command). The serial number and version information are unaffected. Use this setting to avoid changing existing test system code where the manufacturer or model number are verified and to maximize backwards compatibility with the Keysight 34970A and 34972A. The default settings return "Keysight Technologies" followed by the model number "DAQ970A". For more information, see the *IDN? and SYSTem:PERSonA Subsystem commands in the <i>Keysight DAQ970A/DAQ973A Programming Guide</i>.</p> <p>Important: In order to update the instrument firmware from remote, the model number in the *IDN? response must match the actual instrument model number. If you have changed the instrument's *IDN? response to another instrument, when attempting to update the firmware from remote, you will see this error: The instrument is not supported by this firmware file. To update the firmware, either update using the front panel procedure or, from remote, use SYSTem:PERSonA:MODEL to set the *IDN? to match the actual model number, update the firmware, and then use SYSTem:PERSonA:MODEL again to set the *IDN? response to the other model number.</p>
LAN On/Off	Refer to Enable or disable LAN interface
LAN Setting	Refer to LAN Settings
LAN Reset	Refer to LAN Reset
USB Setting	Refer to USB Settings

Power On

Configures the instrument's power-on state and power-on message.

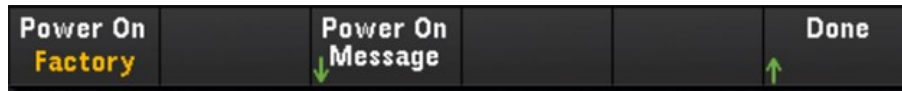

Softkey	Description						
Power On	<table border="1"> <tr> <td>Last</td> <td>At power up, the instrument loads the previous state it was in during power down.</td> </tr> <tr> <td>User Defined</td> <td>At power up, the instrument loads up a user-selected state file.</td> </tr> <tr> <td>Factory Defaults</td> <td>At power up, the instrument loads up the factory default state.</td> </tr> </table>	Last	At power up, the instrument loads the previous state it was in during power down.	User Defined	At power up, the instrument loads up a user-selected state file.	Factory Defaults	At power up, the instrument loads up the factory default state.
Last	At power up, the instrument loads the previous state it was in during power down.						
User Defined	At power up, the instrument loads up a user-selected state file.						
Factory Defaults	At power up, the instrument loads up the factory default state.						
Power On Message	Power On Message sets a message that is displayed when the instrument powers up and when you press [Home] > Help > About. Use the knob or the front panel arrow keys and [Select] key to select the letters. Then press Done to exit and save the message. The message will appear as shown below when you turn the instrument on or press [Home] > Help > About.						

Display Options

Configures the instrument's display.

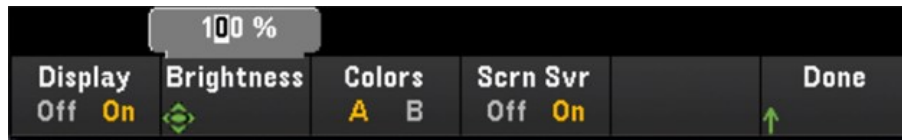

You can enable or disable the display, adjust the brightness (10 to 100%), pick a color scheme, and enable or disable the screen saver. If you turn off the display, press any front panel key to turn it on again. By default, the screen saver increases display life by dimming the display during long periods of inactivity. You may disable this screen saver from the front panel only. The display is enabled when power is cycled, after an instrument reset (*RST), or when you return to local (front panel) operation. Press the [Local] key ([Save Recall] key) to return to the local state.

DMM On/Off

Enables or disables the internal DMM. The **DMM OFF** annunciator will display when internal DMM is disabled. Once disabled, the DMM Digitize option will not be available when selecting the data acquisition mode.

Language

Selects the local language for front panel use.

All messages, context-sensitive help, and help topics appear in the selected language. The menu softkey labels are not translated.

Date/Time

Sets the date and time of the real-time clock in 24-hour format. The real-time clock does not automatically adjust for time zone changes or daylight savings time. Be sure to set the date and time when you first receive your instrument. Use the knob or the front panel arrow keys to set the year, month, day, hour, and minute.

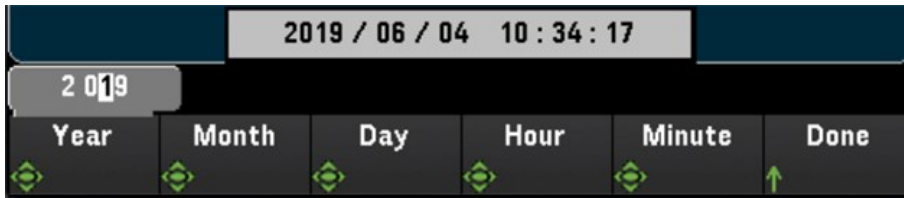

Number Format

Number Format specifies how numbers are displayed on the front panel: 12,345.6 or 12.345,6. Other possibilities also exist. For example, you can use the space as a separator.



Sounds

Enables or disables the tone heard associated when an error is generated from the front panel or remote interface (Beeper), or the click heard when keys are pressed (Key Click).



[View] Menu

Press **[View]** on the front panel to view the scanned memory readings, digitized readings, alarm queue, or error queue. In the View menu, you can also perform various post processing measurements as well as power analysis on the digitized readings.

NOTE

The options within the **[View]** menu will vary depending on the selected data acquisition mode in the **[Home]** menu (**[Home]** > **Acquire** > **Scan**, **DMM Digitize**, or **Digitizer**).

[View] Menu in Scan mode

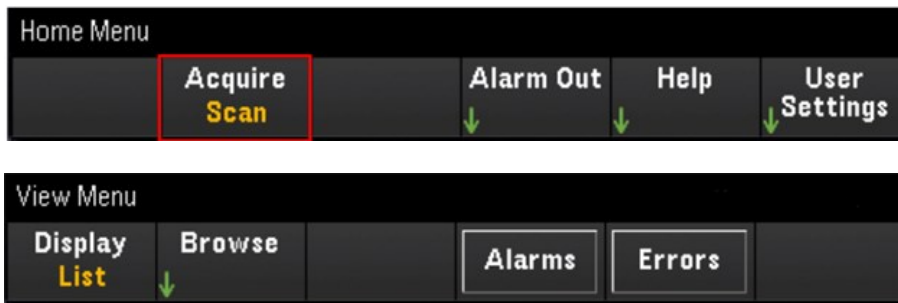

Selecting the display mode

Press the **Display** softkey to select a display mode.

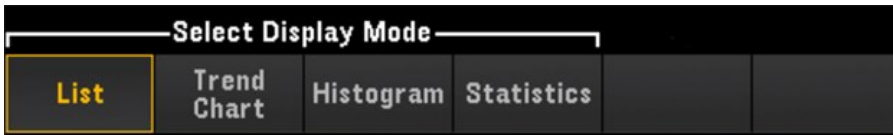

List

Displays the scanned memory readings in list format. Use the knob and arrow keys to scroll across the readings in different pages.

The image shows a screenshot of the 'Scan Memory' list display. The title 'Scan Memory' is at the top left. Below it is a table with four columns: 'Date', 'Time', 'Channel', and 'Reading'. The table contains eight rows of data. At the bottom of the screen, there is a 'View Menu' bar with buttons for 'Display List' (highlighted with a yellow box and a green downward arrow), 'Browse', 'Alarms', and 'Errors'. The text 'Current Page: 1/292' is displayed at the bottom right.

Date	Time	Channel	Reading
6/10/2019	16:07:11.557	101 Armature relay MU...	-9,409 mVDC
6/10/2019	16:07:11.598	101 Armature relay MU...	-180 μVDC
6/10/2019	16:07:11.639	101 Armature relay MU...	-102 μVDC
6/10/2019	16:07:11.680	101 Armature relay MU...	-109 μVDC
6/10/2019	16:07:11.721	101 Armature relay MU...	-160 μVDC
6/10/2019	16:07:11.762	101 Armature relay MU...	-294 μVDC
6/10/2019	16:07:11.803	101 Armature relay MU...	-234 μVDC
6/10/2019	16:07:11.844	101 Armature relay MU...	-249 μVDC

Softkey	Description	
Browse	First Page	Press the First Page softkey and the display will return the scan list back to Page 1.
	Last Sweep	Press the Last Sweep softkey and the readings from the most recent sweep.

Trend Chart

Displays the scanned memory readings in trend chart format. Use the knob and arrow keys to scroll across the readings

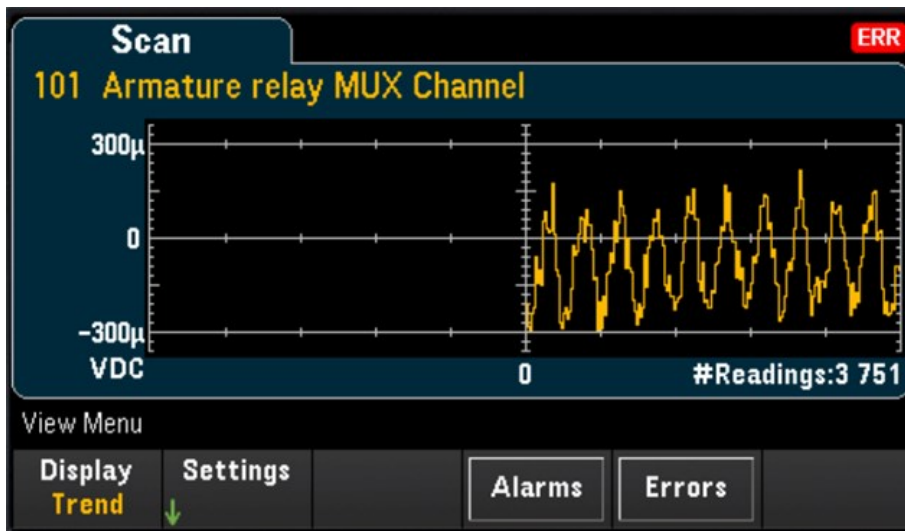

To configure the trend chart, press the **Settings** softkey to bring up the trend chart settings menu.

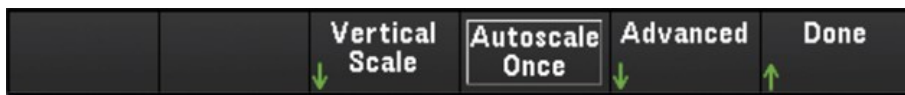

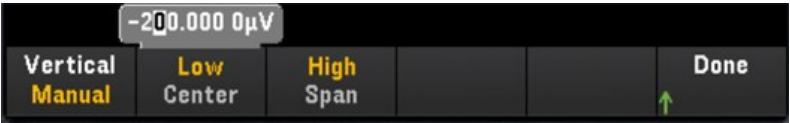
Softkey	Description	
Vertical Scale	Default	Default sets the scale to the measurement range.
	Auto	Auto automatically adjusts the scale to appropriately fit the line currently shown on the screen.
	Manual	 <p>Manual allows you to configure the scale either as High and Low values or as a Span around a Center value. For example, a scale from a Low of 0 V to a High of 5 V is equivalent to a Center of 2.5 V and a Span of 5 V.</p>
Autoscale Once	Press Autoscale Once softkey to automatically scale the trend chart's vertical axis one time based on the scanned memory readings shown on the screen. This also sets the Vertical Scale mode to Manual .	

Advanced Pan Press the **Pan** softkey to pan and select which reading in memory is displayed at the center of the screen. Press and release an arrow key to move the cursor by one display pixel. Hold down an arrow key to move the cursor in 20-display pixel increments.

NOTE

The number of data displayed pixel will vary depending on the zoom level.

Zoom Press the **Zoom** softkey and use the knob or the up/down arrow keys to select the amount of zoom, in percent. You can configure the zoom percentage of the trend chart at 0.02%, 0.05%, 0.1%, 0.2%, 0.5%, 1%, 2%, 5%, 10%, 20%, 50%, 100%, 200%, 500%, or 1000%.

NOTE

To pan one reading at a time, set the zoom level to 1000%. After selecting a reading of your interest, you can then decrease the zoom level, if necessary, to view the surrounding signal.

Cursors Display and control X1, X2, Y1, Y2, and tracking cursors (shown as lines) on the trend chart. X cursors are vertical lines along the sample or time axis and Y cursors are horizontal lines along the measurement (magnitude) axis in units of the selected measurement.

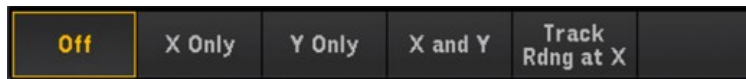

- Press the **Off** softkey to disable the cursors displayed.

- Press the **X Only** softkey to display the X1 and X2 cursors. Press the **X1**, or **X2** softkeys and use the knob or arrow keys to adjust the cursor position along the X axis (time). To keep X1 and X2 cursors at a fixed distance from each other, press the **ΔX Lock** softkey to toggle it to On. The values of each point and the delta between the two points are displayed below the trend chart.

- Press the **Y Only** softkey to display the Y1 and Y2 cursors. Press the **Y1**, or **Y2** softkeys and use the knob or arrow keys to adjust the cursor position along the Y axis (magnitude). To keep Y1 and Y2 cursors at a fixed distance from each other, press the **ΔY Lock** softkey to toggle it to On. To set the Y1 or Y2 cursor to a value that puts it into view on the trend chart, press the **Y1**, or **Y2** softkey followed by the **Place Yn on Screen** softkey. The values of each point and the delta between the two points are displayed below the trend chart.

- Press the **X and Y** softkey to display all the X and Y cursors on the trend chart. Press the **X1**, **X2**, **Y1**, or **Y2** softkeys and use the knob or arrow keys to adjust the cursor position along their respective axis. The values of each point and the delta between the two points are displayed below the trend chart.

- Press the **Track Rdn at X** to view the time and magnitude values of any two points in the trend chart. First, select two readings using the **X1** and **X2** softkeys to position cursors X1 and X2 on the point of interest along the time axis. The Y1 and Y2 cursors will automatically track the position of X1 and X2 cursors respectively and display the respective magnitude axis values of the X1 and X2 cursors. The values of each point and the delta between the two points are displayed below the trend chart. You may also fixed the distance of X1 and X2 cursors by toggling the **ΔX Lock** softkey.

- To record the X and Y data and the delta X and Y data as a screen shot, take a screen shot of the Web UI, not the front panel screen shot utility.

Reset Pan Press the **Reset Pan** softkey to set the center reading to "0".

Below is an example of a trend chart with **Track Rdn** at X function. The violet colored dotted lines are cursors X1,Y1 while the green colored dotted lines are cursors X2,Y2. The values of each point and the delta between the two points are displayed below the trend chart.

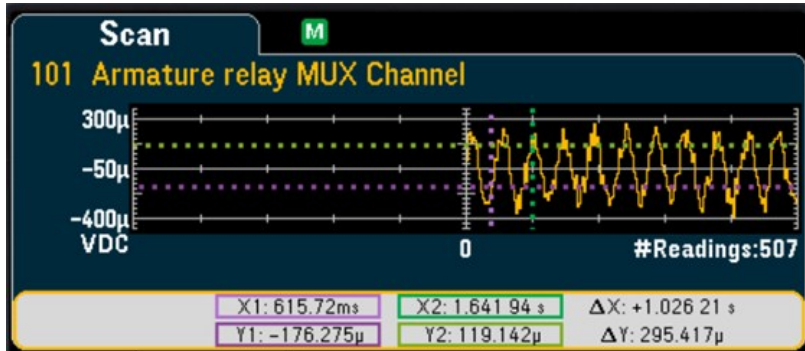

Histogram

Displays the scanned memory readings in histogram format.

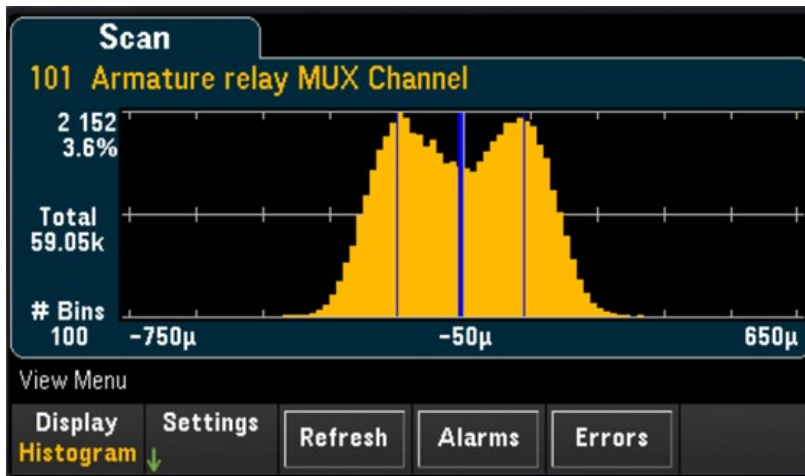

Press the **Settings** softkey to access the cursors menu.



Softkey	Description
Cursors	Press the Cursors softkey to toggle between enabling (On) or disabling (Off) the histogram's cursors
B1	Use the knob or arrow keys to adjust the position of cursor B1 (Violet dotted vertical line).
B2	Use the knob or arrow keys to adjust the position of cursor B2 (Green dotted vertical line).

Press the **Refresh** softkey to recalculate the histogram which will include new readings.

Statistics

Displays the scanned memory readings of a selected channel in statistics format (Maximum, Minimum, Peak to Peak, Average, and Standard Deviation). Toggle between **Statistics** to display the per-channel statistics and **Pk Times** to display the time of occurrence of the per-channel minimum and maximum peak readings.

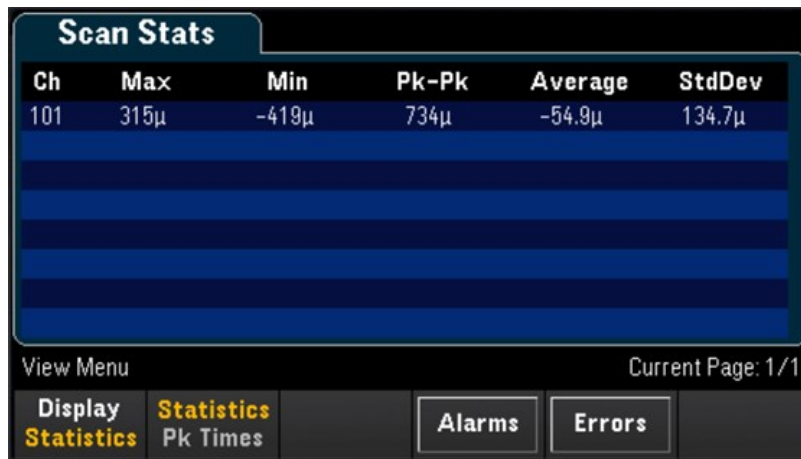

The screenshot shows the 'Scan Stats' menu with a table of statistics for channel 101. The table has six columns: Ch, Max, Min, Pk-Pk, Average, and StdDev. Below the table are navigation buttons: 'View Menu', 'Current Page: 1/1', 'Display Statistics', 'Statistics Pk Times', 'Alarms', and 'Errors'.

Ch	Max	Min	Pk-Pk	Average	StdDev
101	315 μ	-419 μ	734 μ	-54.9 μ	134.7 μ

View the alarm queue

In **View** menu page, press the **Alarms** softkey to display the first 20 alarms, including the reading and time stamp, in the alarm queue. You are only able to view this alarm queue when the alarm limit is configured on the selected channel by pressing **[Alarm]** key on the front panel. See **[Alarm] Menu** for more details.



The screenshot shows the 'Alarms' menu with a table of alarm events. The table has seven columns: Channel, Alarm, Limit, Reading, Unit, Date, and Time. Above the table are status indicators: a green 'S' and a red 'A HI'. Below the table is 'Current Page: 1/1'.

Channel	Alarm	Limit	Reading	Unit	Date	Time
101	1	High	30.63	°C	8/14/2019	14:47:06.137
101	1	High	25.55	°C	8/14/2019	14:47:06.383
101	1	High	25.86	°C	8/14/2019	14:47:06.465
101	1	High	26.56	°C	8/14/2019	14:47:06.547
101	1	High	27.04	°C	8/14/2019	14:47:07.368
101	1	High	25.16	°C	8/14/2019	14:47:08.107
101	1	High	25.82	°C	8/14/2019	14:47:08.928
101	1	High	28.94	°C	8/14/2019	14:47:09.010

View the error queue

In **View** menu page, press **Errors** to display up to the 20 errors in the error queue. Error annunciator, **ERR** is cleared as you read them. When the front panel Error annunciator (ERR) turns on, one or more command syntax, execution, or hardware errors have been detected. A record of up to 20 errors is saved in the instrument's error queue. Errors are retrieved in first-in-first-out (FIFO) order. The first error returned is the first error that was saved. Errors are cleared as you read them. When you have read all errors from the queue, the ERR annunciator turns off and the errors are cleared. The instrument beeps once each time an error is generated. If more than 20 errors have occurred, the last error saved in the queue (the most recent error) is replaced with "Error queue overflow". No additional errors are stored until you remove errors from the queue. If no errors have occurred when you read the error queue, the instrument responds with "No error".

[View] Menu in DMM Digitize or Digitizer mode

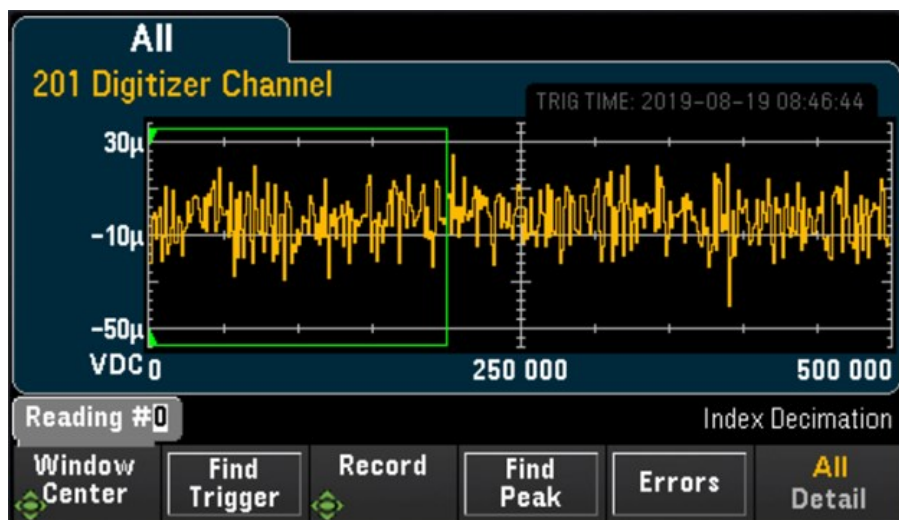
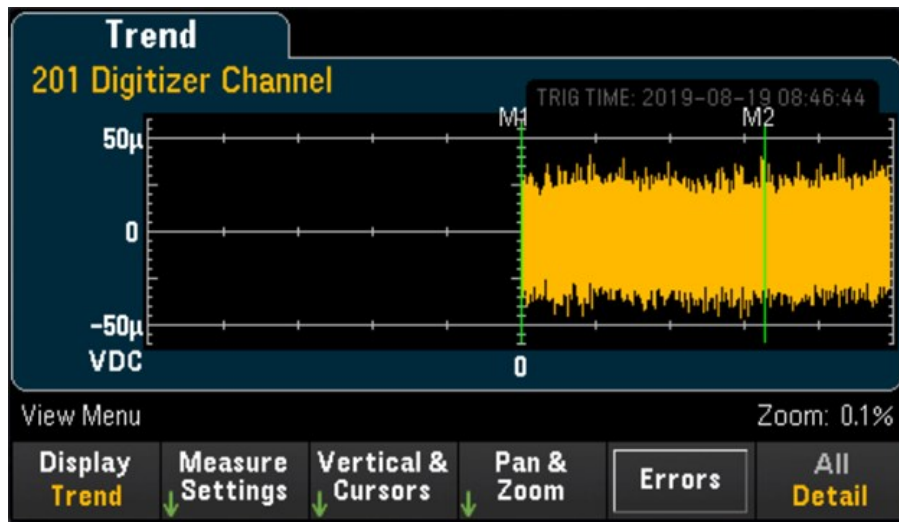

Selecting the display mode

Press the **Display** softkey to select either **Trend** or **Power** as the display mode.

NOTE

By default, only the **Trend** option will be shown. The **Power** option will only be available in the Display menu when the instrument's acquisition mode is set to **Digitizer** at the Home menu and the **Pwr. Alys** (Power Analysis) option is turned on in the Channel menu. See **Power Analysis** for more information.

All/Detail softkey

Press the **All/Detail** softkey to toggle between how the trend graph is shown on the display.

NOTE

In **DMM Digitize** data acquisition mode, the **All/Detail** softkey will only be available when there is a minimum of 401 digitized samples.

All view

When **All** is selected, the instrument will display all the digitized samples on the screen. This allows you to have an overview of the all the digitized samples. In the **All** view, there will also be a window which you can pan across the digitized samples to select a portion of the digitized samples, up to 400,000 samples (maximum window size), to be displayed on the screen in the **Detail** view.

In the image shown below is an example where 500,000 samples were digitized and in the **All** view, all 500,000 samples are shown on the screen. The window encloses 400,000 samples (Readings #50,000 to #450,000) where the center is at reading #250,000. When you switch to **Detail** view, only readings #50,000 to #450,000 will be shown on the screen.

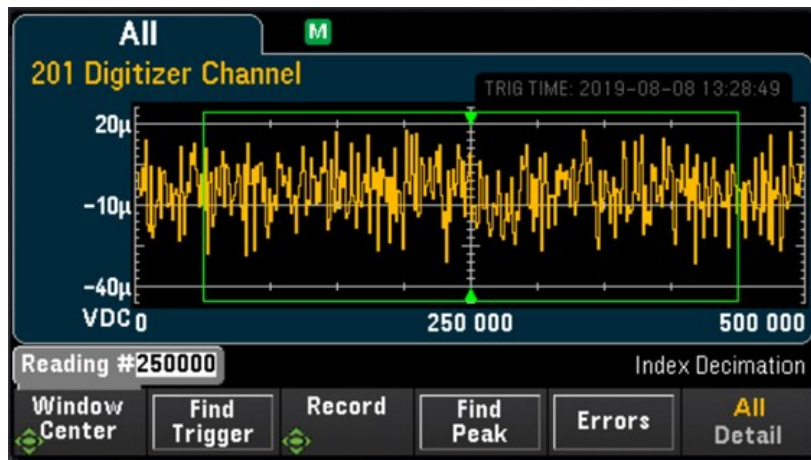

Detail view

The **Detail** view helps to isolate points of interest from the entire set of digitized samples to ease the post processing of the points of interest. When **Detail** view is selected, the instrument will display up to 400,000 samples on the screen based on the samples which are within the window in the **All** view.

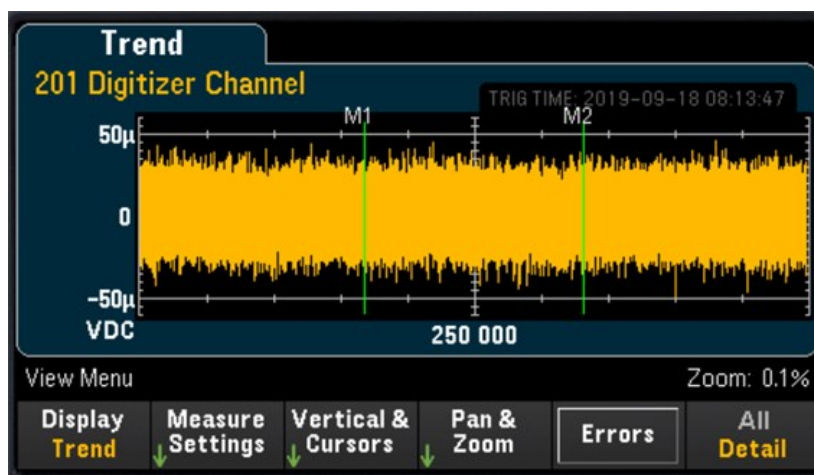

Settings in All view

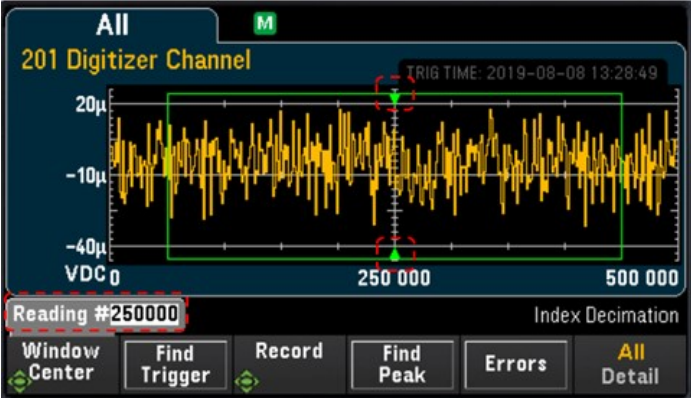

Softkey	Description
Window Center	<p>Press the Window Center softkey and use the knob or arrow keys to shift the position of the window along the screen. The reading at the center of the window is indicated by the pointers at the top and bottom of the window and the number will be displayed above the softkey.</p> 
Find Trigger	<p>Press the Find Trigger softkey and the instrument will locate the trigger points and position the window center on the point where the trigger occurs.</p>
Record	<p>Press the Record softkey and use the knob or arrow keys to scroll through the list of Arm events to view the set of data samples acquired from each respective Arm event number.</p> <p>Important: If a certain Record's data is incomplete, the data of the Record will not be retrievable.</p> <ul style="list-style-type: none"> – Example #1: The digitizer channel is configured as such - <i>Arm Count = 1, Sample Count = 1,000,000</i> and the digitizing operation is initiated. If you abort the operation before 1,000,000 samples have been acquired, all acquired data in the 1st Record prior to the abort cannot be retrieved. – Example #2: The digitizer channel is configured as such - <i>Arm Count = 3, Sample Count = 1,000,000</i> and the digitizing operation is initiated. If you abort the operation during the 3rd Record before 1,000,000 samples have been acquired, all acquired data in the 3rd Record prior to the abort cannot be retrieved. However the acquired data in the 1st and 2nd Record is still retrievable. <p>NOTE The Record softkey will only be available when Digitizer is selected as the data acquisition mode ([Home] > Acquire > Digitizer)</p>
Find Peak	<p>Press the Find Peak softkey to perform decimation on a large set of digitized data. You may pause the decimation process by pressing the Cancel softkey and resume the decimation process by pressing the Resume Find Pk. softkey. Do note that data points that has been decimated cannot be reverted back to its original value.</p> <p>The decimation feature is useful in improving the speed of data throughput. You may digitize a large amount of data per record at a high sampling rate to ensure thorough data capture, but do not need to return all the stored values. Therefore by applying decimation, the instrument returns only the minimum and maximum of actual digitized samples from each group of samples.</p>
Errors	<p>Press the Errors softkey to display up to the 20 errors in the error queue. The error annunciator is cleared as you read them.</p>

Settings in Detail view

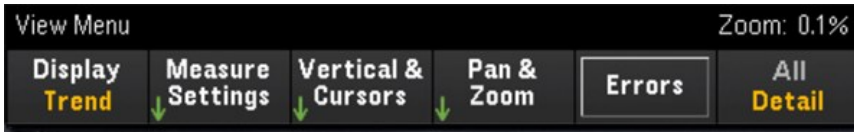

Measure Settings

Press the **Measure Settings** softkey to configure the position of markers and set the mode of data analysis.

NOTE

The **Measure Settings** softkey will only be available once a minimum of 256 samples have been digitized.

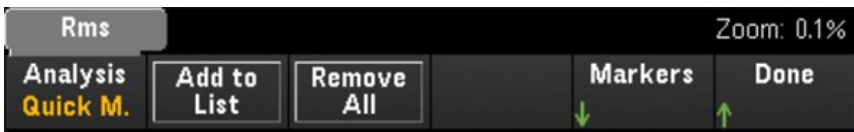

Softkey	Description
Analysis Quick M.	<p>The Quick M. (Quick Measurement) option allows you to add up to four quick measurement modes to be displayed on the screen.</p> <p>To select quick measurement modes for analysis, press Analysis > Quick M. Next, use the knob or the arrow keys to browse through the different options. Once you have selected your desired quick measurement option, press the Add to List softkey to add it into the list of quick measurement that will be displayed.</p> <p>The quick measurement options available are:</p> <ul style="list-style-type: none"> - Rms: Root mean square - DCycle: Duty cycle - PWidth: Positive width - NWidth: Negative width - RTime: Rising time - FTime: Falling time - Period - Freq: Frequency
Statistics	Press Analysis > Statistics to display statistics data such as Minimum, Maximum, Average and Standard Deviation) on the screen.
Add to List	Press the Add to List softkey to add the selected quick measurement mode to be displayed on the screen. You may add up to four quick measurement modes to be displayed. Do note that when you add more than four measurement modes, the most recent measurement mode will replace the first measurement mode which was added (First-in, first-out behavior).
Remove All	Press the Remove All softkey to remove all the quick measurement modes displayed on the screen.

Display Off/On Toggle the **Display Off/On** softkey to enable (**On**) or disable (**Off**) the display of the quick measurements data or statistics data. This setting will be reflected on all the other channels.

NOTE

The **Display Off/On** softkey will only appear when an analysis mode (**Statistics** or a **Quick M.** option) is selected .

Markers Please refer to **Markers softkey** in following section for more information.

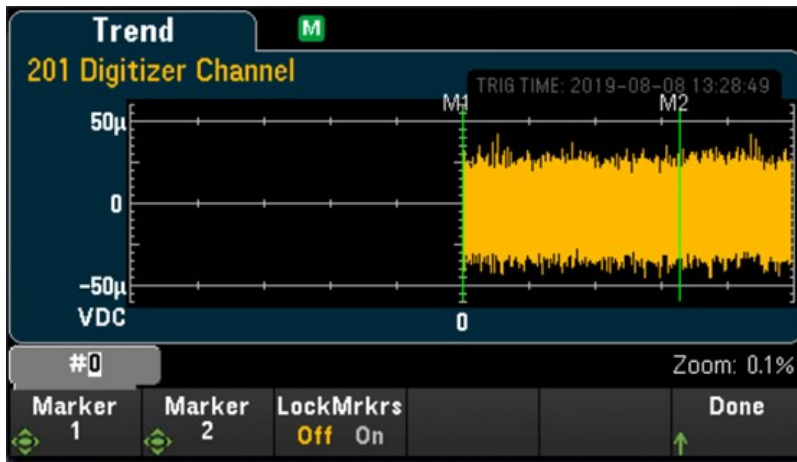
Markers softkey

Markers determine a range of data points which are used to compute the quick measurements and statistics. In the image above, the two markers which are represented by green vertical lines and labeled M1 and M2 respectively.

NOTE

Between Marker 1 and Marker 2, there will be a minimum of 256 data points.

Softkey	Description	
Markers	Marker 1	Press the Marker 1 softkey and use the knob or arrow keys to adjust the position of Marker 1 (M1).
	Marker 2	Press the Marker 2 softkey and use the knob or arrow keys to adjust the position of Marker 2 (M2).
	LockMrkrs On/Off	Press the LockMrkrs softkey to toggle between locking the positions of M1 and M2 in a fixed distance (On) or allowing the position of M1 or M2 to be adjusted independently of each other (Off).

Below are some examples of what you may observe on the screen when you adjust the position of the markers:

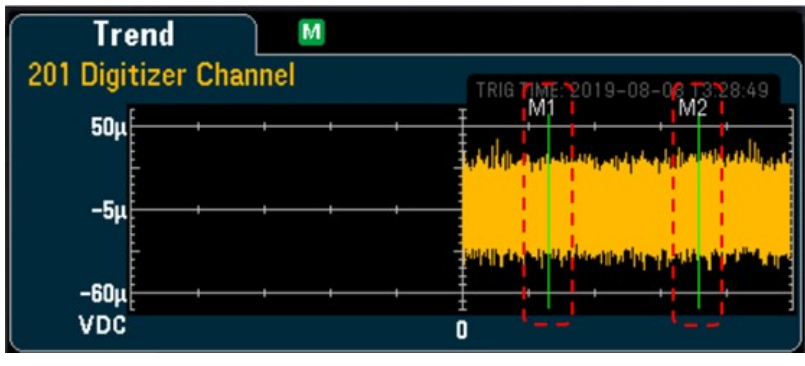
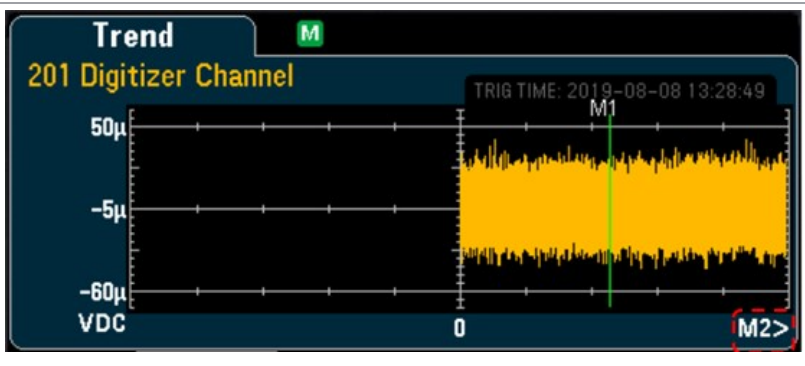
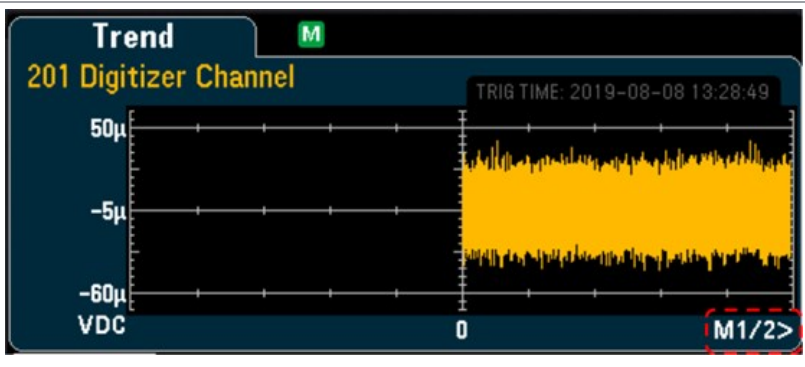
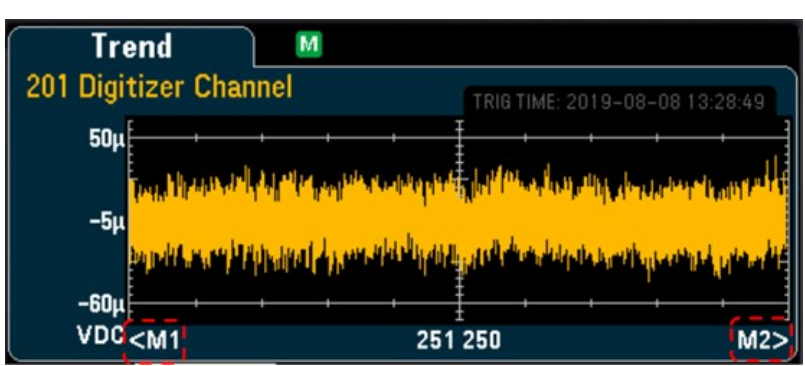
Example	Description
	<p>In the image, Markers 1 and 2 are positioned on data points that are viewable on the screen.</p>
	<p>In this image, Marker 1 is positioned on a data point that is viewable on the screen while Marker 2 is positioned on a data point that is not viewable on the screen.</p> <p>In such cases, an indicator, M2>, will appear at the bottom right of the screen to indicate that Marker 2 is located at a data point towards the right.</p>
	<p>In both images shown, both markers are positioned on data points that are not viewable on the screen.</p> <p>In the first image, an indicator, M1/2>, appears at the bottom right of the screen to indicate that both markers are located towards the right.</p> <p>To bring the markers back into view; First, press the M1 softkey and turn the knob counter-clockwise. This will bring marker M1 back into the edge of the screen. Next, press the M2 softkey and turn the knob counter-clockwise again and this will bring marker M2 to the edge of the screen. Do note that the distance between markers M1 and M2 is now 256 data points.</p>
	<p>In the second image, both markers are on opposite sides. In such cases, indicators <M1 and M2> will appear at the bottom of the screen indicating the direction of markers.</p> <p>To bring the markers back into view; First, press the M1 softkey and turn the knob clockwise. This will bring marker M1 back into the edge of the screen on the left. Next, press the M2 softkey and turn the knob counter-clockwise and this will bring marker M2 to the edge of the screen on the right.</p>

Vertical & Cursors

Press the **Vertical** softkey to configure the vertical scaling of the trend chart and also to access the cursors menu.

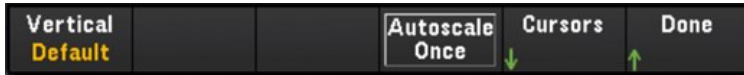

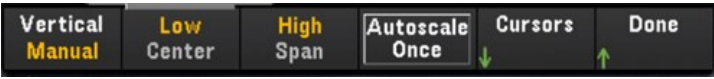
Softkey	Description	
Vertical	Default	Default sets the scale to the measurement range.
	Auto	Auto automatically adjusts the scale to appropriately fit the line currently shown on the screen.
	Manual	 <p>Manual allows you to configure the scale either as High and Low values or as a Span around a Center value. For example, a scale from a Low of 0 V to a High of 5 V is equivalent to a Center of 2.5 V and a Span of 5 V.</p>
Autoscale Once	Press Autoscale Once softkey to automatically scale the trend chart's vertical axis one time based on the digitized data points shown on the screen. This also sets the Vertical Scale mode to Manual .	

Press the **Cursors** softkey to access the Cursors menu.

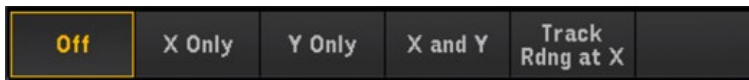

Softkey	Description	
Cursors	Off	Press the Off softkey to disable the cursors displayed.
	X only	Press the X Only softkey to display the X1 and X2 cursors. Press the X1 , or X2 softkeys and use the knob or arrow keys to adjust the cursor position along the X axis (time). To keep X1 and X2 cursors at a fixed distance from each other, press the ΔX Lock softkey to toggle it to On. The values of each point and the delta between the two points are displayed below the trend chart.
	Y only	Press the Y Only softkey to display the Y1 and Y2 cursors. Press the Y1 , or Y2 softkeys and use the knob or arrow keys to adjust the cursor position along the Y axis (magnitude). To keep Y1 and Y2 cursors at a fixed distance from each other, press the ΔY Lock softkey to toggle it to On. To set the Y1 or Y2 cursor to a value that puts it into view on the trend chart, press the Y1 , or Y2 softkey followed by the Place Yn on Screen softkey. The values of each point and the delta between the two points are displayed below the trend chart.
	X and Y	Press the X and Y softkey to display all the X and Y cursors on the trend chart. Press the X1 , X2 , Y1 , or Y2 softkeys and use the knob or arrow keys to adjust the cursor position along their respective axis. The values of each point and the delta between the two points are displayed below the trend chart.
	Track Rdng at X	Press the Track Rdng at X view the time and magnitude values of any two points in the trend chart. First, select two readings using the X1 and X2 softkeys to position cursors X1 and X2 on the point of interest along the time axis. The Y1 and Y2 cursors will automatically track the position of X1 and X2 cursors respectively and display the respective magnitude axis values of the X1 and X2 cursors. The values of each point and the delta between the two points are displayed below the trend chart. You may also fixed the distance of X1 and X2 cursors by toggling the ΔX Lock softkey. See the example shown for more details.

To record the X and Y data and the delta X and Y data as a screen shot, take a screen shot of the Web UI, not the front panel screen shot utility.

Pan & Zoom

Press the **Pan & Zoom** softkey to pan across the trend graph and also configure the zoom level.



Softkey	Description
Pan	Press the Pan softkey to pan and select which reading in memory is displayed at the center of the screen. Press and release the arrow key to move the cursor by one display pixel. Hold down the arrow key to move the cursor in 20-display pixel increments.
Zoom	Press the Zoom softkey and use the knob or the up/down arrow keys to select the amount of zoom, in percent. You can configure the zoom percentage of the trend chart at 0.1%, 0.2%, 0.5%, 1%, 2%, 5%, 10%, 20%, 50%, 100%, 200%, 500%, or 1000%.

The table below shows the list of zoom percentages with its corresponding number of data points per display pixel.

Zoom (%)	Number of data points per display pixel
0.1 %	1000
0.2 %	500
0.5 %	200
1 %	100
2 %	50
5 %	20
10 %	10
20 %	5
50 %	2
100 %	1
200%	0.5
500%	0.2
1000%	0.1

View the error queue

Press the **Errors** softkey to display up to the 20 errors in the error queue. Error annunciator, **ERR**, is cleared as you read them. When the front panel Error annunciator (ERR) turns on, one or more command syntax, execution, or hardware errors have been detected. A record of up to 20 errors is saved in the instrument's error queue.

Errors are retrieved in first-in-first-out (FIFO) order. The first error returned is the first error that was saved. Errors are cleared as you read them. When you have read all errors from the queue, the ERR annunciator turns off and the errors are cleared. The instrument beeps once each time an error is generated. If more than 20 errors have occurred, the last error saved in the queue (the most recent error) is replaced with "Error queue overflow". No additional errors are stored until you remove errors from the queue. If no errors have occurred when you read the error queue, the instrument responds with "No error".

Power Analysis

This section describes how to configure the DAQM909A digitizer channels to perform power analysis in View mode.

Enabling the Power Analysis function in the [Channel] menu

1. In the [Channel] menu, use the knob or arrow keys to select either **Channel 01** or **Channel 03**. DAQM909A's Channel 02 and Channel 04 are always assigned as Power Coupling channels which are coupled to Channel 01 and Channel 03 respectively when the power analysis function is enabled. Therefore, any settings on Channel 02 and Channel 04 will be omitted when power analysis is enabled.

Main Channel	Power Coupling Channel
Channel 01	Channel 02
Channel 03	Channel 04

2. Next, press the **Measure** softkey and select **DCV** and configure the voltage range and sampling rate parameters.



3. Press the **Advanced** softkey followed by the **Pwr. Alys** softkey to toggle between enabling (**On**) or disabling (**Off**) the power analysis function of the selected channel.

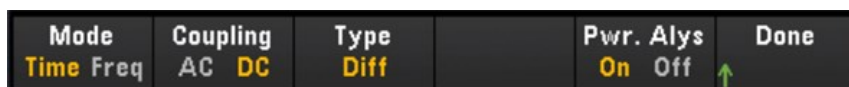

When you enable the power analysis function for the selected channel, the adjacent channel linked to it will be automatically configured as the **Power Coupling** channel. In the example below, **Pwr. Alys** is turned **On** for Channel 01, and Channel 02 is automatically configured as the **Power Coupling** channel.



4. Press the [Scan/Start] key to begin digitizing. Once complete, press the [View] key enter the View menu.

Viewing the Power Analysis results

Press the [View] key to access the View menu.

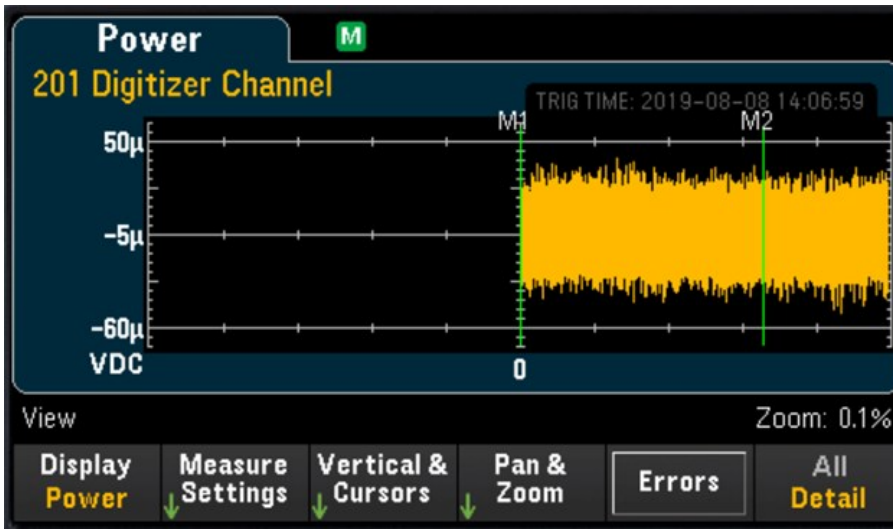

Display softkey

Press the **Display** softkey followed by the **Power** softkey in order to view the results of the power analysis.

NOTE

You may continue to view each channel's current power analysis data that stored in memory, as long as the specified channel did not begin a new digitizing operation as this will overwrite the old data.

Measure Settings softkey

Press the **Measure Settings** softkey to configure the power analysis parameters.

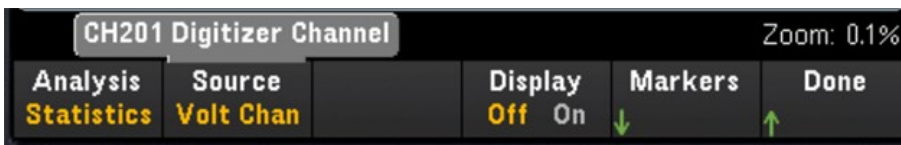

Softkey		Description
Analysis	Statistics	This softkey is static as this is the only analysis option for Power Analysis.
Source	Volt Chan	The selected source will determine the graph that is displayed on the screen. Volt Chan will display the data of the channel assigned to it as a function of voltage, Curr Chan will compute the data of the channel assigned to it and display as a function of current, and V* I computes the data of both Volt Chan and Curr Chan and display the data as a function of power. Press the Source softkey to toggle between voltage channel (Volt Chan), current channel (Curr Chan), or power channel (V* I). For Volt Chan and Curr Chan , use the knob or arrow keys to assign the channels.
	Curr Chan	
	V * I	
Gain		Press the Gain softkey and use the knob or arrow keys to specify the gain value for current value computation for Curr Chan.
Display Off/ On		Toggle the Display Off/On softkey to enable (On) or disable (Off) the display of data statistics on the screen.
Markers		Please refer to Markers softkey for more information.

Vertical & Cursors softkey

Please refer to [Vertical & Cursors](#) for more information.

Pan & Zoom softkey

Please refer to [Pan & Zoom](#) for more information.

View the error queue

Press the **Errors** softkey to display up to the 20 errors in the error queue. Error annunciator, **ERR** is cleared as you read them. When the front panel Error annunciator (ERR) turns on, one or more command syntax, execution, or hardware errors have been detected. A record of up to 20 errors is saved in the instrument's error queue.

Errors are retrieved in first-in-first-out (FIFO) order. The first error returned is the first error that was saved. Errors are cleared as you read them. When you have read all errors from the queue, the ERR annunciator turns off and the errors are cleared. The instrument beeps once each time an error is generated.

If more than 20 errors have occurred, the last error saved in the queue (the most recent error) is replaced with "Error queue overflow". No additional errors are stored until you remove errors from the queue. If no errors have occurred when you read the error queue, the instrument responds with "No error".

[View] Menu Status

In the event where there is no data available to be displayed, the [View] menu will display a status text on the bottom of the display. Below is a list of the status text and its respective description.

Status	Description
"The readings in memory were made with a different set of modules installed, and cannot be graphed"	The instrument is unable to plot the data of the last completed Scan data acquisition operation because the module card has been switched out.
"Pre-Storing"	The instrument is currently collecting PreTrigger samples before entering into Wait for Trigger state.
"No scan data in memory"	No data acquired in Scan mode.
"No digitize data in memory"	No data acquired in DMM Digitize and Digitizer mode.
"Scan in progress"	Scan data acquisition mode is in progress.
"Digitize in progress"	DMM Digitize/ Digitizer data acquisition mode is in progress.
"Wait for arm event"	The digitizer is waiting for arm event before initiating the digitizing process.
"Wait for external event"	The instrument is waiting for an external trigger before initiating data acquisition.
"Wait for internal event"	The instrument is waiting for an internal trigger before initiating data acquisition.
"Wait for alarm event"	The instrument is waiting for an alarm trigger before initiating data acquisition.
"Wait for manual event"	The instrument is waiting for a manual trigger before initiating data acquisition.
"Wait for channel event"	The instrument is waiting for a channel trigger before initiating data acquisition.

[Channel] Menu

Multiplexer modules: Measurements

The Keysight DAQ970A/DAQ973A supports many common measurement functions with the multiplexer module. You can configure the measurement function on the selected channel by pressing **[Channel] > Measure**.

In **Scan** data acquisition mode, selecting **Off** will disable the measurement function in current selected channel. No measurement function will be displayed in the scan list on the selected channel. The default measurement function will set to DCV (DC Voltage).

In **DMM Digitize** data acquisition mode, by default the first suitable channel will automatically configured for **DMM Digitize** and it will be assigned a measurement function (DCV by default). You may switch to another available channel on the plug-in module and configure it for DMM Digitize operation instead. In contrast to **Scan** mode, there is no Off function available because DMM Digitize can only utilize a single configured channel for its digitizing operation. Therefore, the selected channel's measurement function must always be enabled.

Table below shows the overview of each supported multiplexer module on the measurement function. Click on each link to see the details of each configuration step.

Measurement function	Multiplexer modules			
	DAQM900A	DAQM901A	DAQM902A	DAQM908A
Temperature - Thermocouple	√	√	√	
Temperature - RTD		√	√	√ ^[2]
Temperature - Thermistor		√	√	√ ^[2]
Strain - Bridge	√	√	√	√
Strain - Direct		√	√	√ ^[2]
DC Voltage	√	√	√	√
AC Voltage	√	√	√	√
DC Current		√ ^[1]		
AC Current		√ ^[1]		
Resistance	√	√	√	√ ^[2]
Frequency	√	√	√	√
Period	√	√	√	√
Diode		√	√	√
Capacitance		√	√	√

Notes:

[1] Channel 21 and 22 only.

[2] 2-wire measurements only. 4-wire measurements are not supported on DAQM908A multiplexer module.

Temperature

This section describes how to configure the selected channel for temperature measurements from the front panel. Temperature measurements require a temperature transducer probe and the supported probes are thermocouple, thermistor and resistance thermometer (RTD).

Thermocouple

1. Connect a thermocouple to the module's screw terminals.

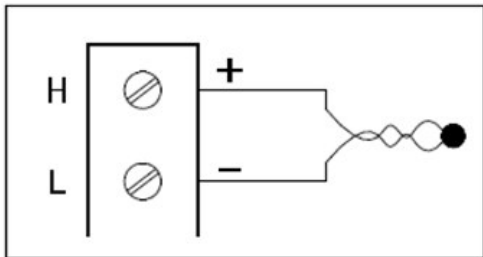

2. Press [Channel] > **Measure**, and select **TEMP** from the selection menu.

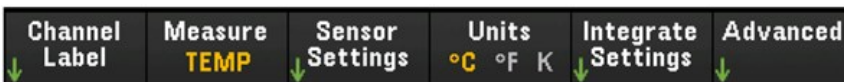

3. Press the **Units** softkey to specify the temperature measurement units as °C (Celsius), °F (Fahrenheit), or K (Kelvin). You can mix temperature units on different channels within the instrument and on the same module.
4. Press **Sensor Settings** > **Sensor**, specify the type of transducer probe used as **TCouple**, and press **Type** softkey to select the type of thermocouple. Supported types are J (default), K, E, T, N, R, B, and S.

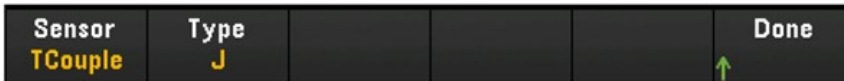

5. Press **Integrated Settings** softkey to select whether the measurement integration time will be specified in terms of Number of Power Line Cycles (**NPLC**) or directly in seconds (**Time**). Only 1, 2, 10, 20, 100, and 200 PLC provide normal mode (line frequency noise) rejection. Selecting 200 PLC provides the best noise rejection and resolution, but the slowest measurements.



Softkey		Description
Integrate	NPLC	Sets the integration time as 0.001, 0.002, 0.006, 0.02, 0.06, 0.2, 1, 2, 10, 20, 100, and 200 Power Line Cycles (PLC). Only 1 PLC and longer times provide normal mode (line frequency noise) rejection. Selecting 100 or 200 PLC provides the best noise rejection and resolution.
	Time	Directly sets the integration time in seconds.

Advance Settings

Press **Advanced** softkey to configure the advanced settings for the measurement.

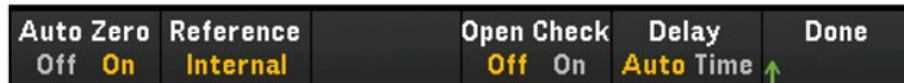

Softkey	Description
Auto Zero Off/ On	Auto Zero provides the most accurate measurements, but requires additional measurement time to perform the zero measurement. With auto zero enabled (On), the instrument internally measures the offset following each measurement. It then subtracts that measurement from the preceding reading. This prevents offset voltages present on the instrument's input circuitry from affecting measurement accuracy. With auto zero disabled (Off), the instrument measures the offset once and subtracts the offset from all subsequent measurements. The instrument takes a new offset measurement each time you change the function, range, or integration time.
Reference Internal External Fixed	<p>Thermocouple measurements require a reference junction temperature. You can input a known fixed reference junction temperature (typically used for external reference junctions), use the internally measured temperature on the module as the reference junction temperature, or use the external thermistor or RTD measurement. Selects the reference junction source as Internal, External, or Fixed.</p> <p>NOTE The External softkey option is not available when DMM Digitize is selected as the acquisition mode.</p>
Open Check Off/ On	<p>Enables (On) or disables (Off) the thermocouple check feature to verify that the thermocouples are properly connected for measurements. When enabled, the instrument performs a resistance measurement with each temperature to check for an open circuit. If one is detected, the result will be shown as +Overload. If this check is not performed, measurement of an open circuit can produce a voltage reading near zero resulting in an invalid temperature reading.</p> <p>NOTE This setting is only available when Scan is selected as the acquisition mode.</p>
Delay Auto/ Time	<p>Selects whether the delay between channels in the scan list will be automatically or manually selected. By selecting Auto, instrument will automatically determine the channel delay based on measurement function, range, integration time, and AC filter setting. By selecting Time, the specified delay (time in seconds) is inserted between the relay closure and the actual measurement on each channel, in addition to any delay that will implicitly occur due to relay settling time.</p> <p>NOTE This setting is only available when Scan is selected as the acquisition mode.</p>

2-wire and 4-wire Thermistor

NOTE This feature is only available when **Scan** is selected as the acquisition mode.

1. Connect a thermistor to the module's screw terminals.

2-wire thermistor:

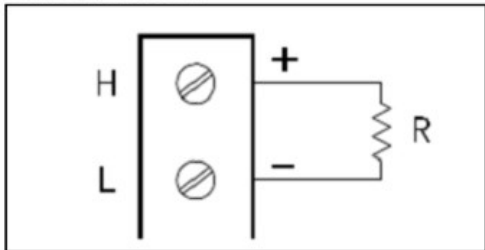

4-wire thermistor:

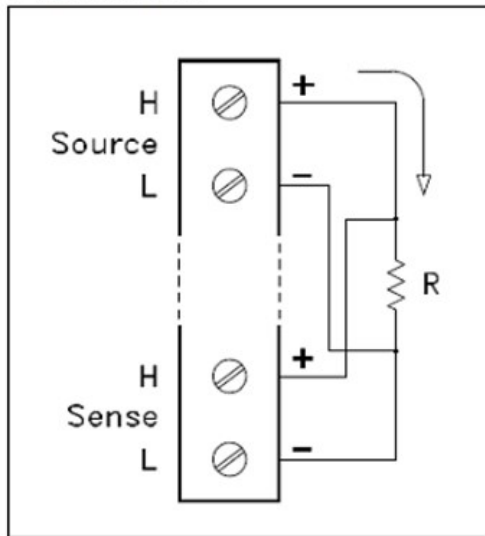

2. Press [Channel] > Measure, and select TEMP from the selection menu.

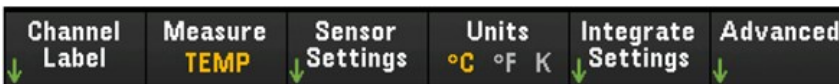

3. Press the Units softkey to specify the temperature measurement units as °C (Celsius), °F (Fahrenheit), or K (Kelvin). You can mix temperature units on different channels within the instrument and on the same module.
4. Press **Sensor Settings** > **Sensor** and select **Thermistor**. Next, toggle the **2-Wire/4-Wire** softkey to specify the type of transducer probe used as **2-wire** or **4-wire Therm**. After that press the **Type** softkey to select the type of thermistor. Supported types are 2.2K, 5K (default), and 10K.

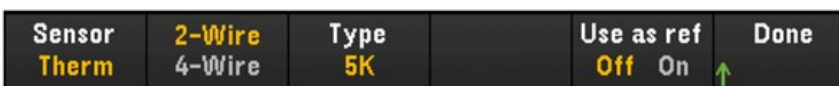

5. Toggle **Use as ref** to enable (**On**) or disable (**Off**) the currently selected channel to be used as the reference channel for subsequent thermocouple measurements that specify an external reference source.

6. Press Integrate Settings softkey to select whether the measurement integration time will be specified in terms of Number of Power Line Cycles (NPLC) or directly in seconds (Time). Only 1, 2, 10, 20, 100, and 200 PLC provide normal mode (line frequency noise) rejection. Selecting 200 PLC provides the best noise rejection and resolution, but the slowest measurements.

Softkey	Description
Integrate	NPLC Sets the integration time as 0.001, 0.002, 0.006, 0.02, 0.06, 0.2, 1, 2, 10, 20, 100, and 200 Power Line Cycles (PLC). Only 1 PLC and longer times provide normal mode (line frequency noise) rejection. Selecting 100 or 200 PLC provides the best noise rejection and resolution.
	Time Directly sets the integration time in seconds.

Advanced Settings

Press **Advanced** softkey to configure the advanced settings for the measurement.

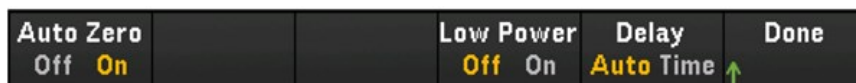

Softkey	Description
Auto Zero Off/ On	Auto Zero provides the most accurate measurements, but requires additional measurement time to perform the zero measurement. With auto zero enabled (On), the instrument internally measures the offset following each measurement. It then subtracts that measurement from the preceding reading. This prevents offset voltages present on the instrument's input circuitry from affecting measurement accuracy. With auto zero disabled (Off), the instrument measures the offset once and subtracts the offset from all subsequent measurements. The instrument takes a new offset measurement each time you change the function, range, or integration time. (There is no auto zero setting for 4-wire measurements).
Low Power Off/ On	Selects the low-power resistance measurement. This sources less current resulting in lower power dissipation, and less self-heating, in the resistance under test. Typically, this is about 1/10th the current sourced for the standard resistance measurements. The approximate current sourced for each measurement range is shown at the bottom of the resistance range softkeys, for example: (~ 1 mA).
Delay Auto/ Time	Selects whether the delay between channels in the scan list will be automatically or manually selected. By selecting Auto , instrument will automatically determine the channel delay based on measurement function, range, integration time, and AC filter setting. By selecting Time , the specified delay (time in seconds) is inserted between the relay closure and the actual measurement on each channel, in addition to any delay that will implicitly occur due to relay settling time.

2-wire and 4-wire RTD

1. Connect an RTD to the module's screw terminals.

2-wire RTD:

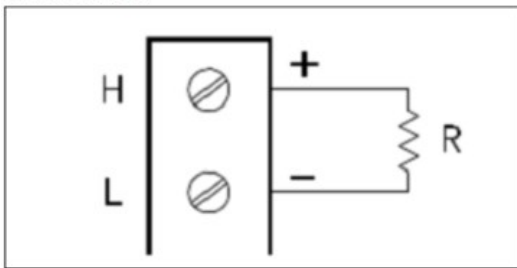

4-wire RTD:

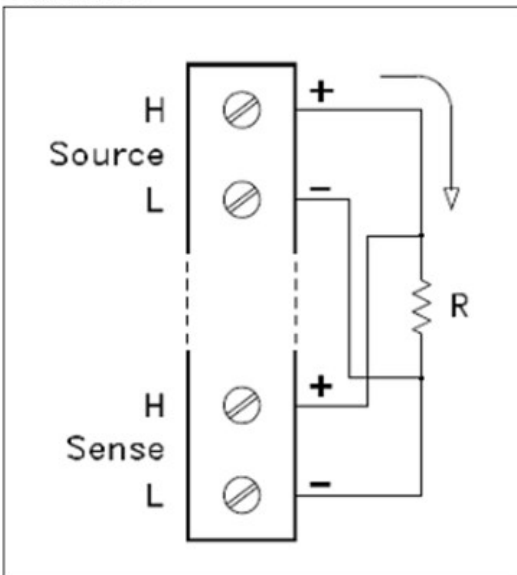

2. Press [Channel] > Measure, and select TEMP from the selection menu.



3. Press the Units softkey to specify the temperature measurement units as °C (Celsius), °F (Fahrenheit), or K (Kelvin). You can mix temperature units on different channels within the instrument and on the same module.
4. Press Sensor Settings > Sensor and select RTD. Next, toggle the 2-Wire/4-Wire softkey to specify the type of transducer probe used as 2-wire or 4-wire RTD. Then, toggle the PT100/PT1000 softkey to select the nominal resistance, R_0 , as PT100 (100 Ω) or PT1000 (1000 Ω). R_0 is the nominal resistance of a RTD at 0 °C.

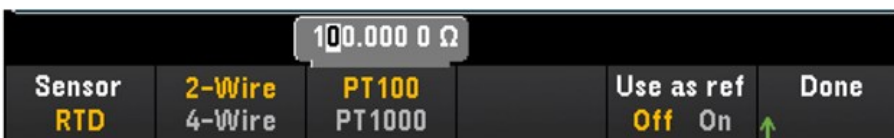

- Press **Use as ref** to enable (**On**) or disable (**Off**) the currently selected channel to be used as the reference channel for subsequent thermocouple measurements that specify an external reference source. This option is not available in **DMM Digitize** mode.
- Press **Integrate Settings** softkey to select whether the measurement integration time will be specified in terms of Number of Power Line Cycles (**NPLC**) or directly in seconds (**Time**). Only 1, 2, 10, 20, 100, and 200 PLC provide normal mode (line frequency noise) rejection. Selecting 200 PLC provides the best noise rejection and resolution, but the slowest measurements.

Softkey	Description
Integrate	NPLC Sets the integration time as 0.001, 0.002, 0.006, 0.02, 0.06, 0.2, 1, 2, 10, 20, 100, and 200 Power Line Cycles (PLC). Only 1 PLC and longer times provide normal mode (line frequency noise) rejection. Selecting 100 or 200 PLC provides the best noise rejection and resolution.
	Time Directly sets the integration time in seconds.

Advanced settings

NOTE

In **DMM Digitize** data acquisition mode, only the **Auto Zero** setting will be available in the **Advanced** settings.

Press **Advanced** softkey to configure the advanced settings for the measurement.



Softkey	Description
Auto Zero Off/ On	Auto Zero provides the most accurate measurements, but requires additional measurement time to perform the zero measurement. With auto zero enabled (On), the instrument internally measures the offset following each measurement. It then subtracts that measurement from the preceding reading. This prevents offset voltages present on the instrument's input circuitry from affecting measurement accuracy. With auto zero disabled (Off), the instrument measures the offset once and subtracts the offset from all subsequent measurements. The instrument takes a new offset measurement each time you change the function, range, or integration time. (There is no auto zero setting for 4-wire measurements).
OffstComp	Offset compensation removes the effects of small DC voltages in the circuit being measured. The technique involves taking the difference between two resistance measurements, one with the current source set to the normal value, and one with the current source set to a lower value.
Low Power Off/ On	Selects the low-power resistance measurement. This sources less current resulting in lower power dissipation, and less self-heating, in the resistance under test. Typically, this is about 1/10th the current sourced for the standard resistance measurements. The approximate current sourced for each measurement range is shown at the bottom of the resistance range softkeys, for example: (~ 1 mA).
Delay Auto/ Time	Selects whether the delay between channels in the scan list will be automatically or manually selected. By selecting Auto , instrument will automatically determine the channel delay based on measurement function, range, integration time, and AC filter setting. By selecting Time , the specified delay (time in seconds) is inserted between the relay closure and the actual measurement on each channel, in addition to any delay that will implicitly occur due to relay settling time.

Strain

This section describes how to configure the selected channel for strain measurements from the front panel. When a force is applied to a body, the body deforms. The deformation per unit length is called strain (ϵ). Strain may be either tensile (+) or compressive (-). The DAQ970A/DAQ973A supports two types of strain measurements which are Bridge configuration and direct resistive method.

Once you have configured strain measurement function in all strain channels, press **[Home]** > **Strain Offset** to measure or specify the unstrained offset that will be subtracted from strain measurements before the strain conversion is performed.

Bridge configuration

Full and half bridge in bending arrangement

This section describes how to configure the selected channel for full and half bending bridge strain gage measurements from the front panel.

1. Connect bridge configuration source to the module's screw terminals.

Full bending bridge:

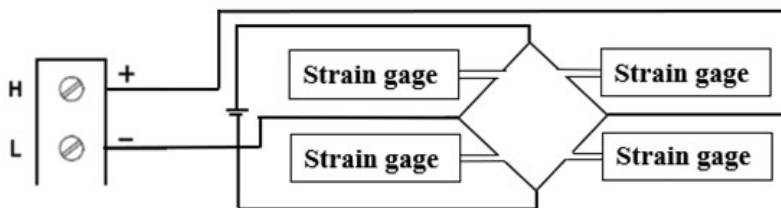

Half bending bridge:

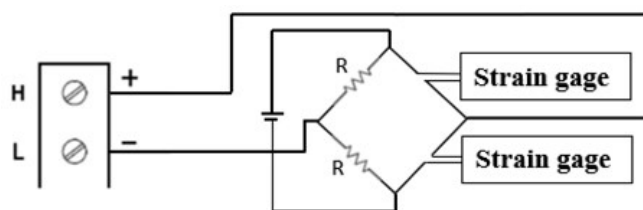

2. Press **[Channel]** > **Measure**, and select **STRAIN** from the selection menu.



- Press **Range** and use the knob or the front panel arrow keys to specify the measurement range. **Auto** (autorange) automatically selects the range for the measurement based on the input. Autoranging is convenient, but it results in slower measurements than using a manual range. Autoranging goes up a range at 120% of the present range, and down a range below 10% of the present range. The **Auto** option is not available in **DMM Digitize** data acquisition mode.

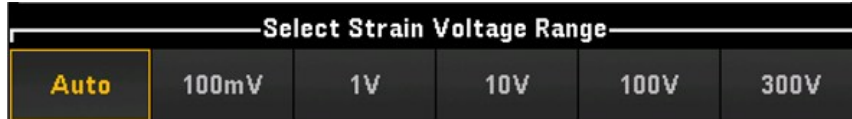

- Press **Sense Settings** > **Sense**, specify the strain measurement method as full and half bridge in bending arrangements.

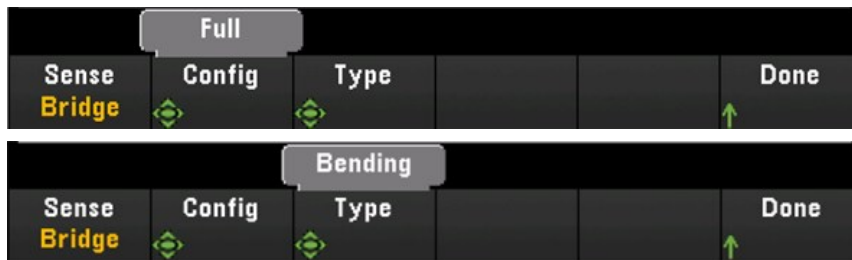

- Press **Gage Settings**, and use the knob or the front panel arrow keys to specify various strain gage settings.

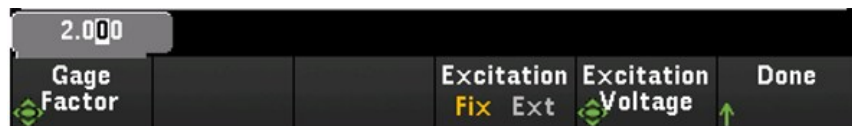

Softkey	Description
Gage Factor	Gage factor is the ratio of the fractional change in resistance to the fractional change in length (strain) along the axis of the gage. The larger the value, the more sensitive strain gage. Gage factor is a dimensionless quantity. The typical value is approximately 2.
Excitation Fix/ Ext	Strain bridge conversions require the voltage of the external bridge excitation. For this voltage, you can dedicate a multiplexer channel to measure the excitation voltage, or can specify a known fixed voltage value. Fixed (Fix) - The fixed value specified by the Excitation Voltage softkey will be used for the strain conversion. External (Ext) - DCV measurements on the enabled reference channel will be used for subsequent strain bridge measurements that specify an external excitation voltage source. Note that the external DCV reference channel must be a lower-numbered channel than the strain channel.
Excitation Voltage	Use the knob or the front panel arrow keys to specify the fixed excitation voltage applied to the bridge by an external voltage source. This value will be used to convert strain bridge measurements on the selected channel.

- Press **Integrate Settings** softkey to select whether the measurement integration time will be specified in terms of Number of Power Line Cycles (**NPLC**) or directly in seconds (**Time**). Only 1, 2, 10, 20, 100, and 200 PLC provide normal mode (line frequency noise) rejection. Selecting 200 PLC provides the best noise rejection and resolution, but the slowest measurements.

Softkey	Description	
Integrate	NPLC	Sets the integration time as 0.001, 0.002, 0.006, 0.02, 0.06, 0.2, 1, 2, 10, 20, 100, and 200 Power Line Cycles (PLC). Only 1 PLC and longer times provide normal mode (line frequency noise) rejection. Selecting 100 or 200 PLC provides the best noise rejection and resolution.
	Time	Directly sets the integration time in seconds.

Advanced settings

NOTE In **DMM Digitize** data acquisition mode, only the **Auto Zero** setting will be available in the **Advanced** settings.

Press **Advanced** to configure the advanced settings for the measurement.

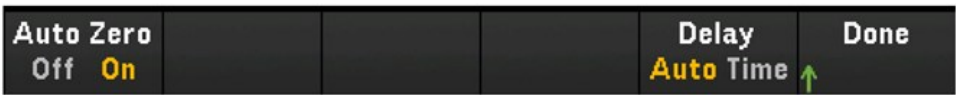

Softkey	Description
Auto Zero Off/ On	Auto Zero provides the most accurate measurements, but requires additional measurement time to perform the zero measurement. With auto zero enabled (On), the instrument internally measures the offset following each measurement. It then subtracts that measurement from the preceding reading. This prevents offset voltages present on the instrument's input circuitry from affecting measurement accuracy. With auto zero disabled (Off), the instrument measures the offset once and subtracts the offset from all subsequent measurements. The instrument takes a new offset measurement each time you change the function, range, or integration time. (There is no auto zero setting for 4-wire measurements).
Delay Auto/ Time	Selects whether the delay between channels in the scan list will be automatically or manually selected. By selecting Auto , instrument will automatically determine the channel delay based on measurement function, range, integration time, and AC filter setting. By selecting Time , the specified delay (time in seconds) is inserted between the relay closure and the actual measurement on each channel, in addition to any delay that will implicitly occur due to relay settling time.

Full and half bridge in Poisson arrangement

This section describes how to configure the selected channel for full and half Poisson bridge strain gage measurements from the front panel.

1. Connect bridge configuration source to the module's screw terminals.

Full bending bridge:

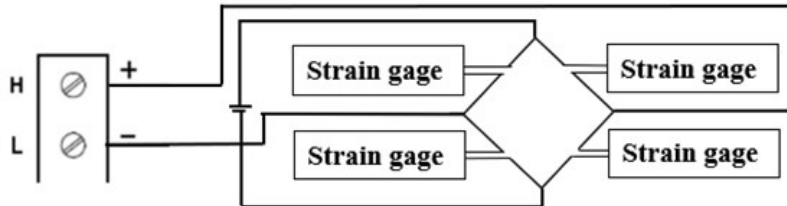

Half bending bridge:

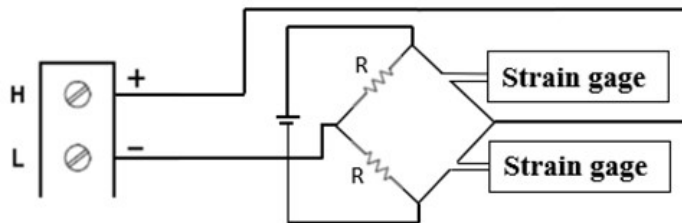

2. Press [Channel] > Measure, and select STRAIN from the selection menu.

Channel Label	Measure STRAIN	Range Auto	Sense Settings	Gage Settings	More >> 1 of 2
------------------	-------------------	---------------	-------------------	------------------	-------------------

3. Press **Range** and use the knob or the front panel arrow keys to specify the measurement range. **Auto** (autorange) automatically selects the range for the measurement based on the input. Autoranging is convenient, but it results in slower measurements than using a manual range. Autoranging goes up a range at 120% of the present range, and down a range below 10% of the present range.

Select Strain Voltage Range					
Auto	100mV	1V	10V	100V	300V

- Press **Sense Settings** > **Sense**, specify the strain measurement method as full and half bridge in Poisson arrangements.



- Press **Gage Settings**, and use the knob or the front panel arrow keys to specify various strain gage settings.

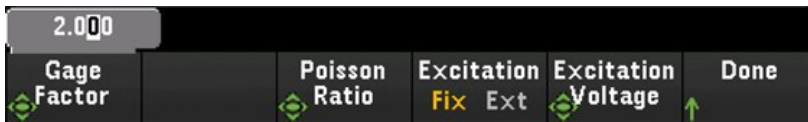

Softkey	Description
Gage Factor	Gage factor is the ratio of the fractional change in resistance to the fractional change in length (strain) along the axis of the gage. The larger the value, the more sensitive strain gage. Gage factor is a dimensionless quantity. The typical value is approximately 2.
Poisson Ratio	Specifies the Poisson ratio of the strain gage. Poisson ratio is defined as the negative ratio of the strain in the transverse direction to the strain in the longitudinal direction.
Excitation Fix/ Ext	Strain bridge conversions require the voltage of the external bridge excitation. For this voltage, you can dedicate a multiplexer channel to measure the excitation voltage, or can specify a known fixed voltage value. Fixed (Fix) - The fixed value specified by the Excitation Voltage softkey will be used for the strain conversion. External (Ext) - DCV measurements on the enabled reference channel will be used for subsequent strain bridge measurements that specify an external excitation voltage source. Note that the external DCV reference channel must be a lower-numbered channel than the strain channel.
Excitation Voltage	Use the knob or the front panel arrow keys to specify the fixed excitation voltage applied to the bridge by an external voltage source. This value will be used to convert strain bridge measurements on the selected channel.

- Press **Integrate Settings** softkey to select whether the measurement integration time will be specified in terms of Number of Power Line Cycles (**NPLC**) or directly in seconds (**Time**). Only 1, 2, 10, 20, 100, and 200 PLC provide normal mode (line frequency noise) rejection. Selecting 200 PLC provides the best noise rejection and resolution, but the slowest measurements.

Softkey	Description
Integrate NPLC	Sets the integration time as 0.001, 0.002, 0.006, 0.02, 0.06, 0.2, 1, 2, 10, 20, 100, and 200 Power Line Cycles (PLC). Only 1 PLC and longer times provide normal mode (line frequency noise) rejection. Selecting 100 or 200 PLC provides the best noise rejection and resolution.
Time	Directly sets the integration time in seconds.

Advanced settings

NOTE

In **DMM Digitize** data acquisition mode, only the **Auto Zero** setting will be available in the **Advanced** settings.

Press **Advanced** to configure the advanced settings for the measurement.

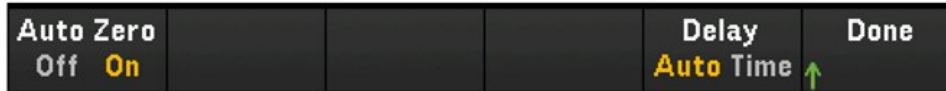

Softkey	Description
Auto Zero Off/ On	Auto Zero provides the most accurate measurements, but requires additional measurement time to perform the zero measurement. With auto zero enabled (On), the instrument internally measures the offset following each measurement. It then subtracts that measurement from the preceding reading. This prevents offset voltages present on the instrument's input circuitry from affecting measurement accuracy. With auto zero disabled (Off), the instrument measures the offset once and subtracts the offset from all subsequent measurements. The instrument takes a new offset measurement each time you change the function, range, or integration time. (There is no auto zero setting for 4-wire measurements).
Delay Auto/ Time	Selects whether the delay between channels in the scan list will be automatically or manually selected. By selecting Auto , instrument will automatically determine the channel delay based on measurement function, range, integration time, and AC filter setting. By selecting Time , the specified delay (time in seconds) is inserted between the relay closure and the actual measurement on each channel, in addition to any delay that will implicitly occur due to relay settling time.

Full bridge in bending Poisson arrangement

This section describes how to configure the selected channel for full bending Poisson bridge strain gage measurements from the front panel.

1. Connect bridge configuration source to the module's screw terminals.

Full bending bridge:

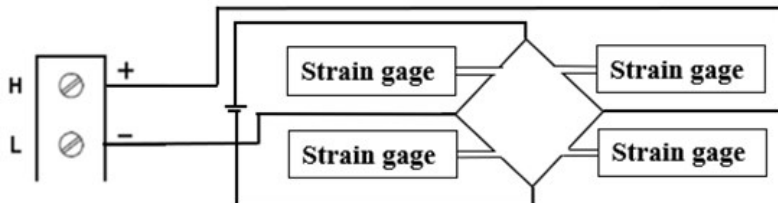

2. Press [Channel] > Measure, and select STRAIN from the selection menu.

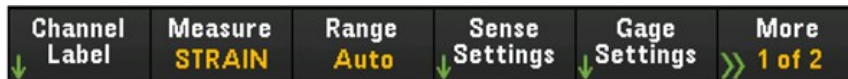

3. Press Range and use the knob or the front panel arrow keys to specify the measurement range. Auto (autorange) automatically selects the range for the measurement based on the input. Autoranging is convenient, but it results in slower measurements than using a manual range. Autoranging goes up a range at 120% of the present range, and down a range below 10% of the present range.



4. Press Sense Settings > Sense, specify the strain measurement method as full bridge in bending Poisson arrangement.

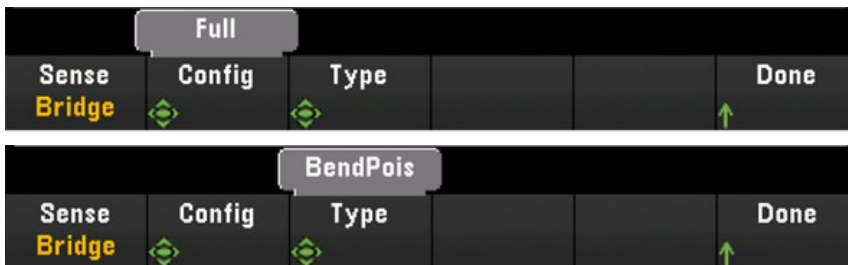

5. Press **Gage Settings**, and use the knob or the front panel arrow keys to specify various strain gage settings.

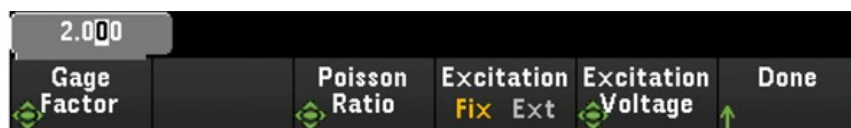

Softkey	Description
Gage Factor	Gage factor is the ratio of the fractional change in resistance to the fractional change in length (strain) along the axis of the gage. The larger the value, the more sensitive strain gage. Gage factor is a dimensionless quantity. The typical value is approximately 2.
Poisson Ratio	Specifies the Poisson ratio of the strain gage. Poisson ratio is defined as the negative ratio of the strain in the transverse direction to the strain in the longitudinal direction.
Excitation Fix/ Ext	Strain bridge conversions require the voltage of the external bridge excitation. For this voltage, you can dedicate a multiplexer channel to measure the excitation voltage, or can specify a known fixed voltage value. Fixed (Fix) - The fixed value specified by the Excitation Voltage softkey will be used for the strain conversion. External (Ext) - DCV measurements on the enabled reference channel will be used for subsequent strain bridge measurements that specify an external excitation voltage source. Note that the external DCV reference channel must be a lower-numbered channel than the strain channel.
Excitation Voltage	Use the knob or the front panel arrow keys to specify the fixed excitation voltage applied to the bridge by an external voltage source. This value will be used to convert strain bridge measurements on the selected channel.

6. Press **Integrate Settings** softkey to select whether the measurement integration time will be specified in terms of Number of Power Line Cycles (**NPLC**) or directly in seconds (**Time**). Only 1, 2, 10, 20, 100, and 200 PLC provide normal mode (line frequency noise) rejection. Selecting 200 PLC provides the best noise rejection and resolution, but the slowest measurements.

Softkey	Description	
Integrate	NPLC	Sets the integration time as 0.001, 0.002, 0.006, 0.02, 0.06, 0.2, 1, 2, 10, 20, 100, and 200 Power Line Cycles (PLC). Only 1 PLC and longer times provide normal mode (line frequency noise) rejection. Selecting 100 or 200 PLC provides the best noise rejection and resolution.
	Time	Directly sets the integration time in seconds.

Advanced settings**NOTE**

In **DMM Digitize** data acquisition mode, only the **Auto Zero** setting will be available in the **Advanced** settings.

Press **Advanced** to configure the advanced settings for the measurement.

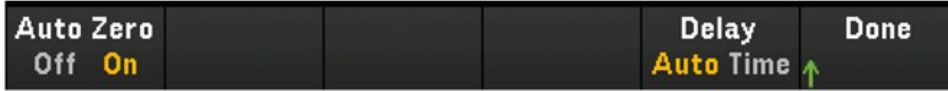

Softkey	Description
Auto Zero Off/ On	Auto Zero provides the most accurate measurements, but requires additional measurement time to perform the zero measurement. With auto zero enabled (On), the instrument internally measures the offset following each measurement. It then subtracts that measurement from the preceding reading. This prevents offset voltages present on the instrument's input circuitry from affecting measurement accuracy. With auto zero disabled (Off), the instrument measures the offset once and subtracts the offset from all subsequent measurements. The instrument takes a new offset measurement each time you change the function, range, or integration time. (There is no auto zero setting for 4-wire measurements).
Delay Auto/ Time	Selects whether the delay between channels in the scan list will be automatically or manually selected. By selecting Auto , instrument will automatically determine the channel delay based on measurement function, range, integration time, and AC filter setting. By selecting Time , the specified delay (time in seconds) is inserted between the relay closure and the actual measurement on each channel, in addition to any delay that will implicitly occur due to relay settling time.

Quarter bridge arrangement

This section describes how to configure the selected channel for quarter bridge strain gage measurements from the front panel.

1. Connect bridge configuration source to module's screw terminals

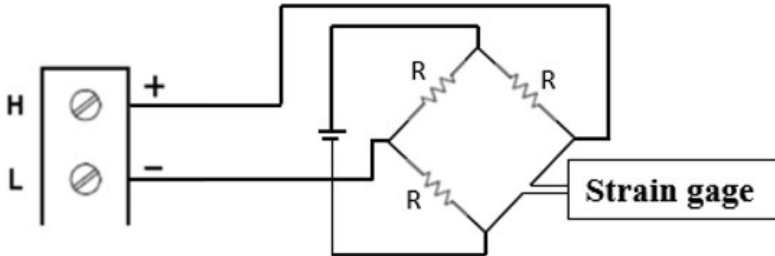

2. Press [Channel] > Measure, and select STRAIN from the selection menu.

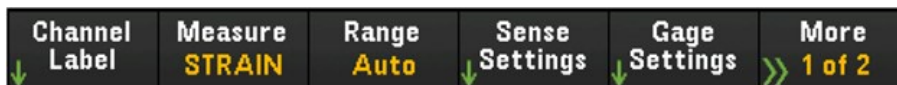

3. Press Range and use the knob or the front panel arrow keys to specify the measurement range. Auto (autorange) automatically selects the range for the measurement based on the input. Autoranging is convenient, but it results in slower measurements than using a manual range. Autoranging goes up a range at 120% of the present range, and down a range below 10% of the present range.



4. Press Sense Settings > Sense, specify the strain measurement method as quarter bridge arrangement.



- Press **Gage Settings**, and use the knob or the front panel arrow keys to specify various strain gage settings.

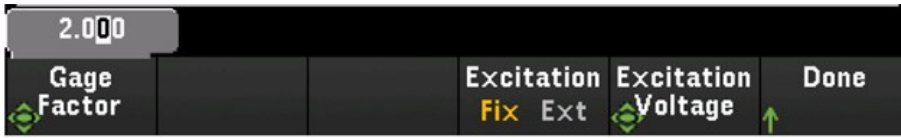

Softkey	Description
Gage Factor	Gage factor is the ratio of the fractional change in resistance to the fractional change in length (strain) along the axis of the gage. The larger the value, the more sensitive strain gage. Gage factor is a dimensionless quantity. The typical value is approximately 2.
Excitation Fix/ Ext	Strain bridge conversions require the voltage of the external bridge excitation. For this voltage, you can dedicate a multiplexer channel to measure the excitation voltage, or can specify a known fixed voltage value. Fixed (Fix) - The fixed value specified by the Excitation Voltage softkey will be used for the strain conversion. External (Ext) - DCV measurements on the enabled reference channel will be used for subsequent strain bridge measurements that specify an external excitation voltage source. Note that the external DCV reference channel must be a lower-numbered channel than the strain channel.
Excitation Voltage	Use the knob or the front panel arrow keys to specify the fixed excitation voltage applied to the bridge by an external voltage source. This value will be used to convert strain bridge measurements on the selected channel.

- Press **Integrate Settings** softkey to select whether the measurement integration time will be specified in terms of Number of Power Line Cycles (**NPLC**) or directly in seconds (**Time**). Only 1, 2, 10, 20, 100, and 200 PLC provide normal mode (line frequency noise) rejection. Selecting 200 PLC provides the best noise rejection and resolution, but the slowest measurements.

Softkey	Description
Integrate NPLC	Sets the integration time as 0.001, 0.002, 0.006, 0.02, 0.06, 0.2, 1, 2, 10, 20, 100, and 200 Power Line Cycles (PLC). Only 1 PLC and longer times provide normal mode (line frequency noise) rejection. Selecting 100 or 200 PLC provides the best noise rejection and resolution.
Time	Directly sets the integration time in seconds.

Advanced settings

NOTE

In **DMM Digitize** data acquisition mode, only the **Auto Zero** setting will be available in the **Advanced** settings.

Press **Advanced** to configure the advanced settings for the measurement.

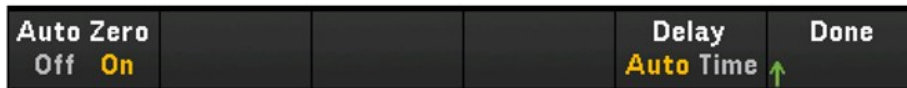

Softkey	Description
Auto Zero Off/ On	Auto Zero provides the most accurate measurements, but requires additional measurement time to perform the zero measurement. With auto zero enabled (On), the instrument internally measures the offset following each measurement. It then subtracts that measurement from the preceding reading. This prevents offset voltages present on the instrument's input circuitry from affecting measurement accuracy. With auto zero disabled (Off), the instrument measures the offset once and subtracts the offset from all subsequent measurements. The instrument takes a new offset measurement each time you change the function, range, or integration time. (There is no auto zero setting for 4-wire measurements).
Delay Auto/ Time	Selects whether the delay between channels in the scan list will be automatically or manually selected. By selecting Auto , instrument will automatically determine the channel delay based on measurement function, range, integration time, and AC filter setting. By selecting Time , the specified delay (time in seconds) is inserted between the relay closure and the actual measurement on each channel, in addition to any delay that will implicitly occur due to relay settling time.

Direct resistive method

This section describes how to configure the selected channel for direct 2-wire and 4-wire strain gage measurements from the front panel. The measurement configurations for 2-wire and 4-wire direct resistive are same, below descriptions explained by using 2-wire resistance measurements.

1. Connect direct resistive source to the module's screw terminals.

2-wire direct strain:

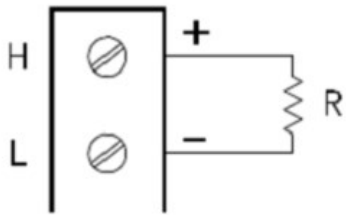

4-wire direct strain:

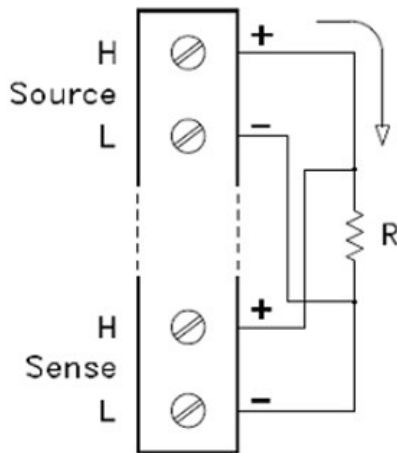

2. Press [Channel] > Measure, and select STRAIN from the selection menu.

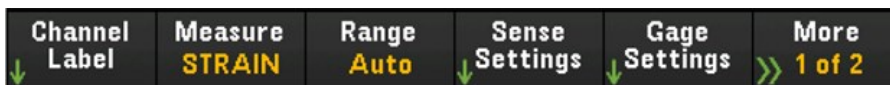

3. Press Sense Settings > Sense, specify the strain measurement method as direct 2-wire or 4-wire. Do note that the Range softkey (as seen in step 2) will no longer be available for configuration once direct 2-wire or 4-wire method is selected.



4. Press **Gage Settings**, and use the knob or the front panel arrow keys to specify various strain gage settings.

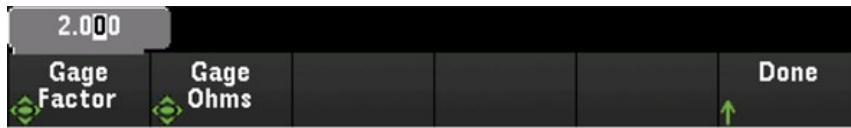

Softkey	Description
Gage Factor	Gage factor is the ratio of the fractional change in resistance to the fractional change in length (strain) along the axis of the gage. The larger the value, the more sensitive strain gage. Gage factor is a dimensionless quantity. The typical value is approximately 2.
Gage Ohms	Gage resistance to be used to convert direct strain measurements on the selected channel.

5. Press **Integrate Settings** softkey to select whether the measurement integration time will be specified in terms of Number of Power Line Cycles (**NPLC**) or directly in seconds (**Time**). Only 1, 2, 10, 20, 100, and 200 PLC provide normal mode (line frequency noise) rejection. Selecting 200 PLC provides the best noise rejection and resolution, but the slowest measurements.

Softkey	Description
Integrate	NPLC Sets the integration time as 0.001, 0.002, 0.006, 0.02, 0.06, 0.2, 1, 2, 10, 20, 100, and 200 Power Line Cycles (PLC). Only 1 PLC and longer times provide normal mode (line frequency noise) rejection. Selecting 100 or 200 PLC provides the best noise rejection and resolution.
	Time Directly sets the integration time in seconds.

Advanced settings

NOTE

In **DMM Digitize** data acquisition mode, only the **Auto Zero** setting will be available in the **Advanced** settings.

Press **Advanced** to configure the advanced settings for the measurement.

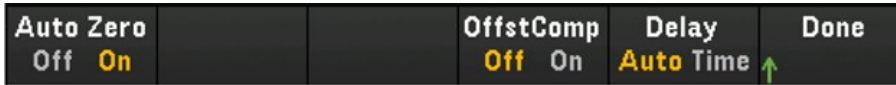

Softkey	Description
Auto Zero Off/ On	Auto Zero provides the most accurate measurements, but requires additional measurement time to perform the zero measurement. With auto zero enabled (On), the instrument internally measures the offset following each measurement. It then subtracts that measurement from the preceding reading. This prevents offset voltages present on the instrument's input circuitry from affecting measurement accuracy. With auto zero disabled (Off), the instrument measures the offset once and subtracts the offset from all subsequent measurements. The instrument takes a new offset measurement each time you change the function, range, or integration time. (There is no auto zero setting for 4-wire measurements).
OffstComp Off/ On	Offset compensation removes the effects of small DC voltages in the circuit being measured. The technique involves taking the difference between two resistance measurements, one with the current source set to the normal value, and one with the current source set to a lower value.
Delay Auto/Time	Selects whether the delay between channels in the scan list will be automatically or manually selected. By selecting Auto , instrument will automatically determine the channel delay based on measurement function, range, integration time, and AC filter setting. By selecting Time , the specified delay (time in seconds) is inserted between the relay closure and the actual measurement on each channel, in addition to any delay that will implicitly occur due to relay settling time.

DC Voltage

This section describes how to configure the selected channel for DC voltage measurements from the front panel.

1. Connect the voltage source to the module's screw terminals.

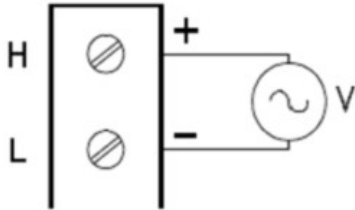

2. Press [Channel] > Measure, and select DCV from the selection menu.

Channel Label	Measure DCV	Range Auto	Integrate Settings	Advanced
---------------	-------------	------------	--------------------	----------

3. Press **Range** and use the knob or the front panel arrow keys to specify the measurement range. **Auto** (autorange) automatically selects the range for the measurement based on the input. Autoranging is convenient, but it results in slower measurements than using a manual range. Autoranging goes up a range at 120% of the present range, and down a range below 10% of the present range.

NOTE

Autorange is not supported on the DMM Digitize data acquisition mode.

Select DC Voltage Range					
Auto	100mV	1V	10V	100V	300V

4. Press **Integrate Settings** softkey to select whether the measurement integration time will be specified in terms of Number of Power Line Cycles (**NPLC**) or directly in seconds (**Time**). Only 1, 2, 10, 20, 100, and 200 PLC provide normal mode (line frequency noise) rejection. Selecting 200 PLC provides the best noise rejection and resolution, but the slowest measurements.

Softkey	Description	
Integrate	NPLC	Sets the integration time as 0.001, 0.002, 0.006, 0.02, 0.06, 0.2, 1, 2, 10, 20, 100, and 200 Power Line Cycles (PLC). Only 1 PLC and longer times provide normal mode (line frequency noise) rejection. Selecting 100 or 200 PLC provides the best noise rejection and resolution.
	Time	Directly sets the integration time in seconds.

Advanced settings

Press **Advanced** to configure the advanced settings for the measurement.

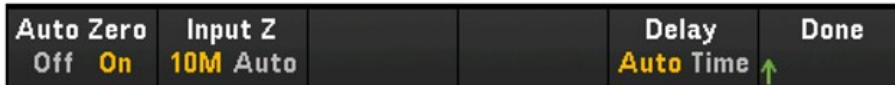

Softkey	Description
Auto Zero Off/ On	<p>Auto Zero provides the most accurate measurements, but requires additional measurement time to perform the zero measurement. With auto zero enabled (On), the instrument internally measures the offset following each measurement. It then subtracts that measurement from the preceding reading. This prevents offset voltages present on the instrument's input circuitry from affecting measurement accuracy. With auto zero disabled (Off), the instrument measures the offset once and subtracts the offset from all subsequent measurements. The instrument takes a new offset measurement each time you change the function, range, or integration time. (There is no auto zero setting for 4-wire measurements).</p> <p>NOTE This setting is available when Scan or DMM Digitize is selected as the acquisition mode.</p>
Input Z 10M/ Auto	<p>Specifies the measurement terminal input impedance, which is either 10 MΩ (10M) or high impedance (Auto). The Auto mode selects high impedance (> 10 GΩ) for the 100 mV, 1 V, and 10 V ranges, and 10 MΩ for the 100 V and 300 V ranges. In most situations, 10 MΩ is high enough to not load most circuits, but low enough to make readings suitable for high impedance circuits. It also leads to readings with less noise than the high impedance option, which is included for situations where the 10 MΩ load is significant.</p> <p>NOTE This setting is available when Scan or DMM Digitize is selected as the acquisition mode.</p>
Delay Auto/ Time	<p>Selects whether the delay between channels in the scan list will be automatically or manually selected. By selecting Auto, instrument will automatically determine the channel delay based on measurement function, range, integration time, and AC filter setting. By selecting Time, the specified delay (time in seconds) is inserted between the relay closure and the actual measurement on each channel, in addition to any delay that will implicitly occur due to relay settling time.</p> <p>NOTE This setting is only available when Scan is selected as the acquisition mode.</p>

AC Voltage

NOTE

The AC Voltage measurement option will only be available when **Scan** is selected as the acquisition mode.

This section describes how to configure the selected channel for AC voltage measurements from the front panel.

1. Connect the AC voltage source to the module's screw terminals.

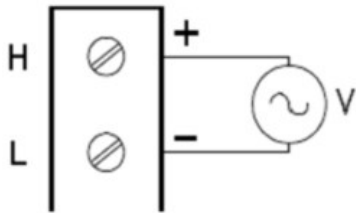

2. Press [Channel] > Measure, and select **ACV** from the selection menu.

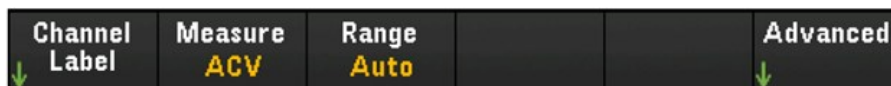

3. Press **Range** and use the knob or the front panel arrow keys to specify the measurement range. **Auto** (autorange) automatically selects the range for the measurement based on the input. Autoranging is convenient, but it results in slower measurements than using a manual range. Autoranging goes up a range at 120% of the present range, and down a range below 10% of the present range.

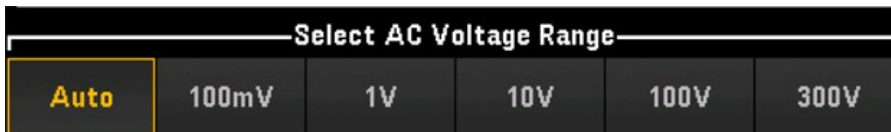

Advanced settings

Press **Advanced** to configure the advanced settings for the measurement.

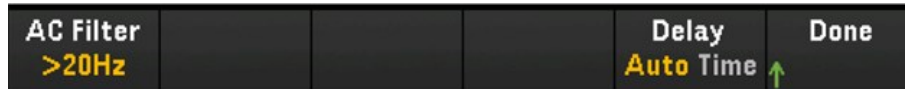

Softkey	Description
AC Filter	Specifies which AC filter to use. The instrument uses three different AC filters that enable you either to optimize low frequency accuracy or achieve faster AC settling following a change in input signal amplitude. The three filters are 3 Hz , 20 Hz , and 200 Hz , and you should generally select the highest frequency filter whose frequency is less than that of the signal you are measuring, because higher frequency filters result in faster measurements. For example, when you are measuring a signal between 20 and 200 Hz, you should use the 20 Hz filter. If measurement speed is not an issue, choosing a lower frequency filter may result in quieter measurements, depending on the signal that you are measuring.
Delay Auto/ Time	Selects whether the delay between channels in the scan list will be automatically or manually selected. By selecting Auto , instrument will automatically determine the channel delay based on measurement function, range, integration time, and AC filter setting. By selecting Time , the specified delay (time in seconds) is inserted between the relay closure and the actual measurement on each channel, in addition to any delay that will implicitly occur due to relay settling time.

DC Current

NOTE

DC Current measurement is supported only on DAQM901A's channels 21 and 22.

This section describes how to configure the selected channel for DC current measurements from the front panel.

1. Connect DC current source to the module's screw terminals.

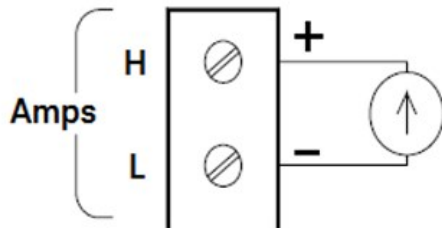

2. Press [Channel] > Measure, and select DCI from the selection menu.

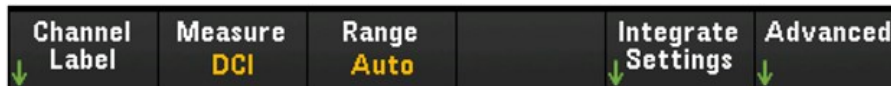

3. Press **Range** and use the knob or the front panel arrow keys to specify the measurement range. **Auto** (autorange) automatically selects the range for the measurement based on the input. Autoranging is convenient, but it results in slower measurements than using a manual range. Autoranging goes up a range at 120% of the present range, and down a range below 10% of the present range. The **Auto** option is not available in **DMM Digitize** data acquisition mode.

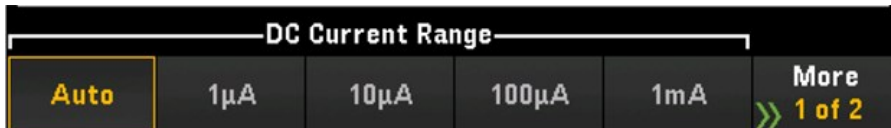

4. Press **Integrate Settings** softkey to select whether the measurement integration time will be specified in terms of Number of Power Line Cycles (**NPLC**) or directly in seconds (**Time**). Only 1, 2, 10, 20, 100, and 200 PLC provide normal mode (line frequency noise) rejection. Selecting 200 PLC provides the best noise rejection and resolution, but the slowest measurements.

Softkey	Description
Integrate	NPLC
	Sets the integration time as 0.001, 0.002, 0.006, 0.02, 0.06, 0.2, 1, 2, 10, 20, 100, and 200 Power Line Cycles (PLC). Only 1 PLC and longer times provide normal mode (line frequency noise) rejection. Selecting 100 or 200 PLC provides the best noise rejection and resolution.
	Time
	Directly sets the integration time in seconds.

Advanced settings

NOTE

In **DMM Digitize** data acquisition mode, only the **Auto Zero** setting will be available in the **Advanced** settings.

Press **Advanced** to configure the advanced settings for the measurement.

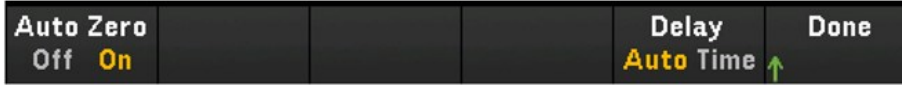

Softkey	Description
Auto Zero Off/ On	Auto Zero provides the most accurate measurements, but requires additional measurement time to perform the zero measurement. With auto zero enabled (On), the instrument internally measures the offset following each measurement. It then subtracts that measurement from the preceding reading. This prevents offset voltages present on the instrument's input circuitry from affecting measurement accuracy. With auto zero disabled (Off), the instrument measures the offset once and subtracts the offset from all subsequent measurements. The instrument takes a new offset measurement each time you change the function, range, or integration time. (There is no auto zero setting for 4-wire measurements).
Delay Auto/ Time	Selects whether the delay between channels in the scan list will be automatically or manually selected. By selecting Auto , instrument will automatically determine the channel delay based on measurement function, range, integration time, and AC filter setting. By selecting Time , the specified delay (time in seconds) is inserted between the relay closure and the actual measurement on each channel, in addition to any delay that will implicitly occur due to relay settling time.

AC Current

NOTE

The AC Current measurement option will only be available when **Scan** is selected as the acquisition mode.

AC Current measurement is supported only on DAQM901A's channels 21 and 22.

This section describes how to configure the selected channel for AC current measurements from the front panel.

1. Connect a current source to the module's screw terminals.

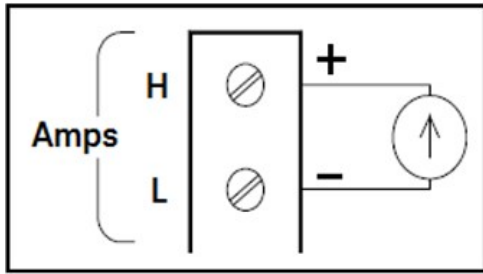

2. Press [Channel] > Measure, and select ACI from the selection menu.

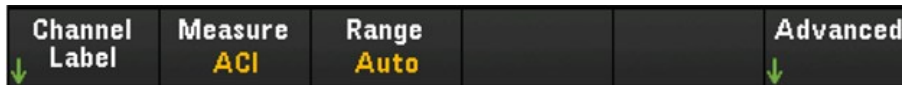

3. Press **Range** and use the knob or the front panel arrow keys to specify the measurement range. **Auto** (autorange) automatically selects the range for the measurement based on the input. Autoranging is convenient, but it results in slower measurements than using a manual range. Autoranging goes up a range at 120% of the present range, and down a range below 10% of the present range.

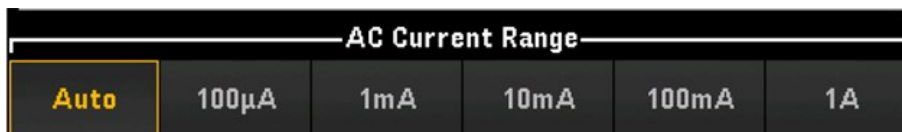

Advanced settings

Press **Advanced** to configure the advanced settings for the measurement.

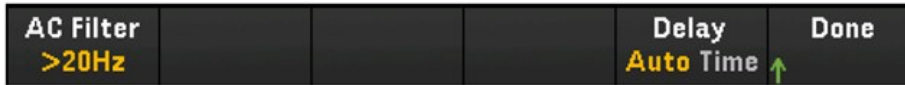

Softkey	Description
AC Filter	Specifies which AC filter to use. The instrument uses three different AC filters that enable you either to optimize low frequency accuracy or achieve faster AC settling following a change in input signal amplitude. The three filters are 3 Hz , 20 Hz , and 200 Hz , and you should generally select the highest frequency filter whose frequency is less than that of the signal you are measuring, because higher frequency filters result in faster measurements. For example, when you are measuring a signal between 20 and 200 Hz, you should use the 20 Hz filter. If measurement speed is not an issue, choosing a lower frequency filter may result in quieter measurements, depending on the signal that you are measuring.
Delay Auto/ Time	Selects whether the delay between channels in the scan list will be automatically or manually selected. By selecting Auto , instrument will automatically determine the channel delay based on measurement function, range, integration time, and AC filter setting. By selecting Time , the specified delay (time in seconds) is inserted between the relay closure and the actual measurement on each channel, in addition to any delay that will implicitly occur due to relay settling time.

Resistance

This section describes how to configure the selected channel for 2-wire and 4-wire measurements from the front panel. The measurement configurations for 2-wire and 4-wire resistance are same, below descriptions explained by using 2-wire resistance measurements.

1. Connect resistance source to the module's screw terminals.

2-wire ohms:

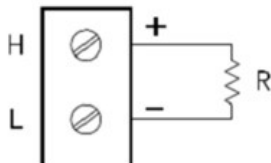

4-wire ohms:

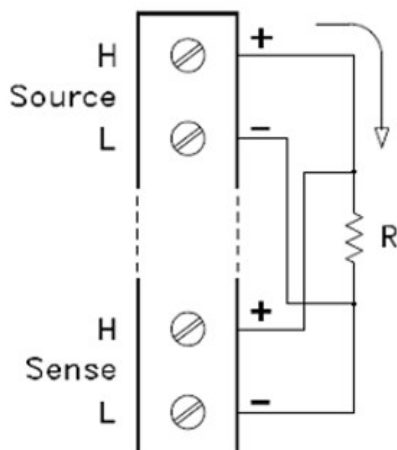

2. Press [Channel] > Measure, and select OHMS or OHMS 4W from the selection menu.

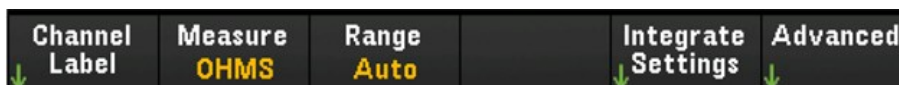

3. Press **Range** and use the knob or the front panel arrow keys to specify the measurement range. **Auto** (only available when **Scan** is selected as the data acquisition mode) automatically selects the range for the measurement based on the input. Autoranging is convenient, but it results in slower measurements than using a manual range. Autoranging goes up a range at 120% of the present range, and down a range below 10% of the present range. The **Auto** option is not available in **DMM Digitize** data acquisition mode.

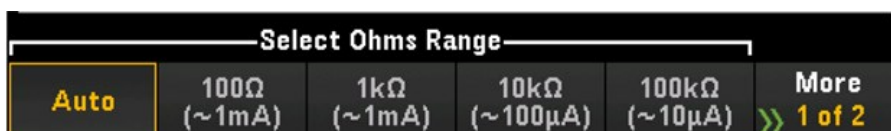

- Press **Integrate Settings** softkey to select whether the measurement integration time will be specified in terms of Number of Power Line Cycles (**NPLC**) or directly in seconds (**Time**). Only 1, 2, 10, 20, 100, and 200 PLC provide normal mode (line frequency noise) rejection. Selecting 200 PLC provides the best noise rejection and resolution, but the slowest measurements.

Softkey	Description	
Integrate	NPLC	Sets the integration time as 0.001, 0.002, 0.006, 0.02, 0.06, 0.2, 1, 2, 10, 20, 100, and 200 Power Line Cycles (PLC). Only 1 PLC and longer times provide normal mode (line frequency noise) rejection. Selecting 100 or 200 PLC provides the best noise rejection and resolution.
	Time	Directly sets the integration time in seconds.

Advanced settings

NOTE In **DMM Digitize** data acquisition mode, only the **Auto Zero** setting will be available in the **Advanced** settings.

Press **Advanced** to configure the advanced settings for the measurement.



Softkey	Description
Auto Zero Off/ On	Auto Zero provides the most accurate measurements, but requires additional measurement time to perform the zero measurement. With auto zero enabled (On), the instrument internally measures the offset following each measurement. It then subtracts that measurement from the preceding reading. This prevents offset voltages present on the instrument's input circuitry from affecting measurement accuracy. With auto zero disabled (Off), the instrument measures the offset once and subtracts the offset from all subsequent measurements. The instrument takes a new offset measurement each time you change the function, range, or integration time. (There is no auto zero setting for 4-wire measurements).
OffstCmp Off/ On	Offset compensation removes the effects of small DC voltages in the circuit being measured. The technique involves taking the difference between two resistance measurements, one with the current source set to the normal value, and one with the current source set to a lower value.
Low Power Off/ On	Selects the low-power resistance measurement. This sources less current resulting in lower power dissipation, and less self-heating, in the resistance under test. Typically, this is about 1/10th the current sourced for the standard resistance measurements. The approximate current sourced for each measurement range is shown at the bottom of the resistance range softkeys, for example: (~ 1 mA).
Delay Auto/ Time	Selects whether the delay between channels in the scan list will be automatically or manually selected. By selecting Auto , instrument will automatically determine the channel delay based on measurement function, range, integration time, and AC filter setting. By selecting Time , the specified delay (time in seconds) is inserted between the relay closure and the actual measurement on each channel, in addition to any delay that will implicitly occur due to relay settling time.

Frequency and Period

NOTE

The Frequency and Period measurement option will only be available when **Scan** is selected as the acquisition mode.

This section describes how to configure the selected channel for frequency and period measurements from the front panel.

1. Connect an AC source to the module's screw terminals.

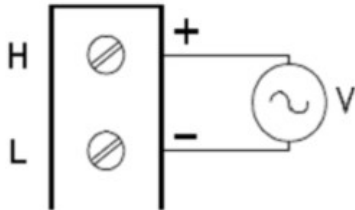

2. Press [Channel] > **Measure**, and select **FREQ** or **PERIOD** from the selection menu.

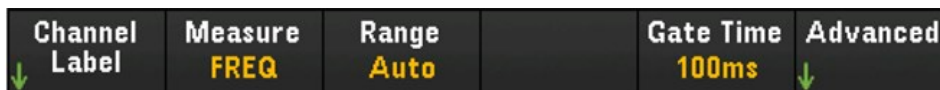

3. Press **Range** and use the knob or the front panel arrow keys to specify the measurement range. **Auto** (autorange) automatically selects the range for the measurement based on the input. Autoranging is convenient, but it results in slower measurements than using a manual range. Autoranging goes up a range at 120% of the present range, and down a range below 10% of the present range.

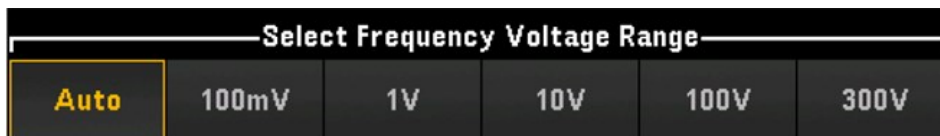

4. Press **Gate Time** to specify the measurement's aperture (integration time) as 1 ms, 10 ms, 100 ms, or 1 s.

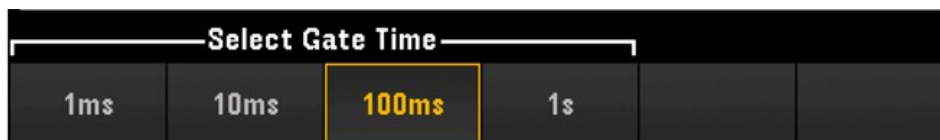

Advanced settings

Press **Advanced** to configure the advanced settings for the measurement.

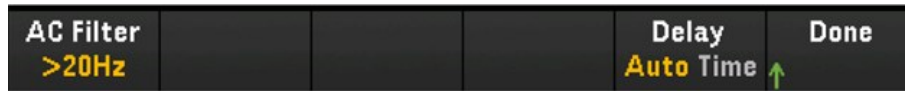

Softkey	Description
AC Filter	Specifies which AC filter to use. The instrument uses three different AC filters that enable you either to optimize low frequency accuracy or achieve faster AC settling following a change in input signal amplitude. The three filters are 3 Hz , 20 Hz , and 200 Hz , and you should generally select the highest frequency filter whose frequency is less than that of the signal you are measuring, because higher frequency filters result in faster measurements. For example, when you are measuring a signal between 20 and 200 Hz, you should use the 20 Hz filter. If measurement speed is not an issue, choosing a lower frequency filter may result in quieter measurements, depending on the signal that you are measuring.
Delay Auto/ Time	Selects whether the delay between channels in the scan list will be automatically or manually selected. By selecting Auto , instrument will automatically determine the channel delay based on measurement function, range, integration time, and AC filter setting. By selecting Time , the specified delay (time in seconds) is inserted between the relay closure and the actual measurement on each channel, in addition to any delay that will implicitly occur due to relay settling time.

Diode

NOTE

The Diode measurement option will only be available when **Scan** is selected as the acquisition mode.

This section describes how to configure the selected channel for diode test from the front panel.

1. Connect diode source to the module's screw terminals.

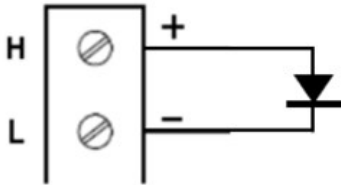

2. Press [Channel] > Measure, and select DIODE from the selection menu.



Advanced settings

Press **Advanced** to configure the advanced settings for the measurement.

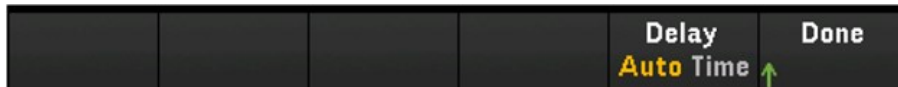

Softkey	Description
Delay Auto/ Time	Selects whether the delay between channels in the scan list will be automatically or manually selected. By selecting Auto , instrument will automatically determine the channel delay based on measurement function, range, integration time, and AC filter setting. By selecting Time , the specified delay (time in seconds) is inserted between the relay closure and the actual measurement on each channel, in addition to any delay that will implicitly occur due to relay settling time.

Capacitance

NOTE

The Capacitance measurement option will only be available when **Scan** is selected as the acquisition mode.

This section describes how to configure the selected channel for capacitance measurements from the front panel.

1. Connect capacitance source to the module's screw terminals.

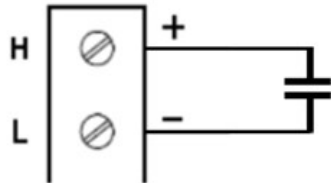

2. Press [Channel] > **Measure**, and select **CAP** from the selection menu.

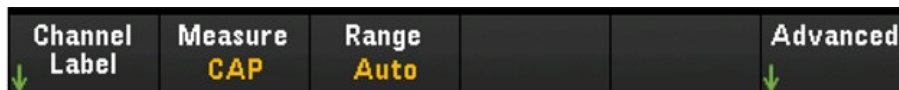

3. Press **Range** and use the knob or the front panel arrow keys to specify the measurement range. Auto (autorange) automatically selects the range for the measurement based on the input. Autoranging is convenient, but it results in slower measurements than using a manual range. Autoranging goes up a range at 120% of the present range, and down a range below 10% of the present range.

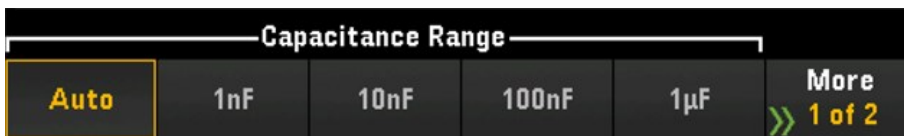

Advanced settings

Press **Advanced** to configure the advanced settings for the measurement.



Softkey	Description
Delay Auto/ Time	Selects whether the delay between channels in the scan list will be automatically or manually selected. By selecting Auto , instrument will automatically determine the channel delay based on measurement function, range, integration time, and AC filter setting. By selecting Time , the specified delay (time in seconds) is inserted between the relay closure and the actual measurement on each channel, in addition to any delay that will implicitly occur due to relay settling time.

Multiplexer modules: Switch mode

The multiplexer modules (DAQM900A, DAQM901A, DAQM902A, and DAQM908A) are also able to operate in switch mode which enables you to open and close channels independently. The section below will describe the steps to enable and configure the switch mode.

1. Press the **[Channel]** key to access the Channel menu. In the example below, Channel 101 of a DAQM901A module in slot 1, labeled as OVEN is set up to measure temperature in degrees °C using a type J thermocouple.

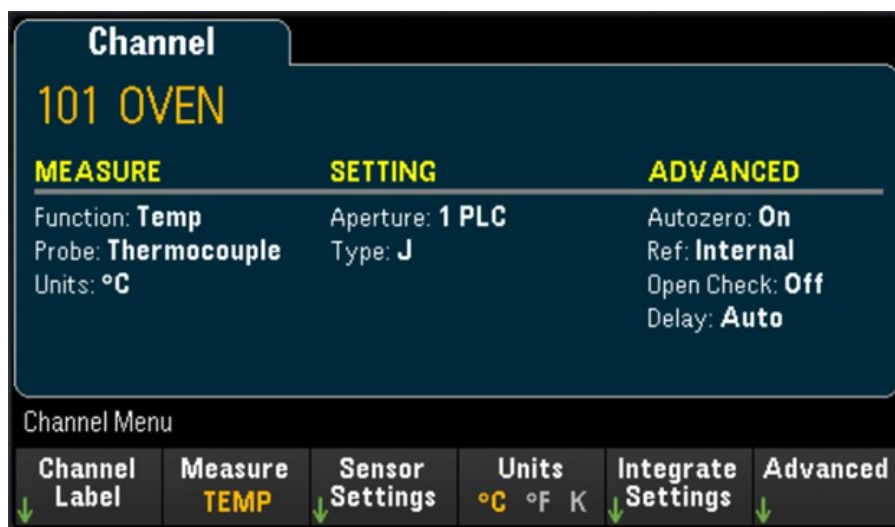

2. Press the **[Module]** key to go to the Module menu. Next, press the **Scan List** softkey.

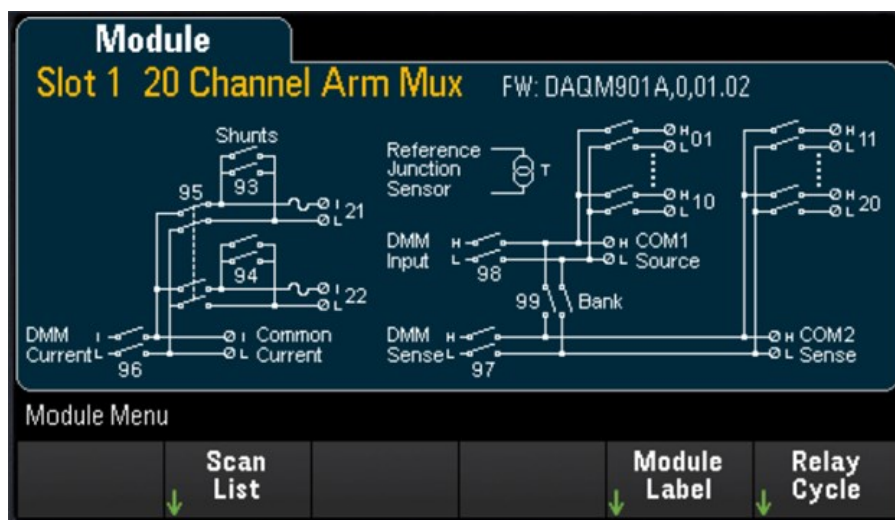

- You would notice that Channel 101 label is OVEN and the Scan Status is ON. Press the **Remove from Scan** softkey and you will be prompted to confirm your action. Press the **Yes** softkey to confirm removing all channels on the module from the scan list. This action turns off the measurements for the channels on the module and places the module in switch mode.



Channel	Scan Status
101 OVEN	ON
102 Armature relay MUX Channel	OFF
103 Armature relay MUX Channel	OFF
104 Armature relay MUX Channel	OFF
105 Armature relay MUX Channel	OFF
106 Armature relay MUX Channel	OFF
107 Armature relay MUX Channel	OFF
108 Armature relay MUX Channel	OFF

Current Page: 1/3

Remove From Scan Done

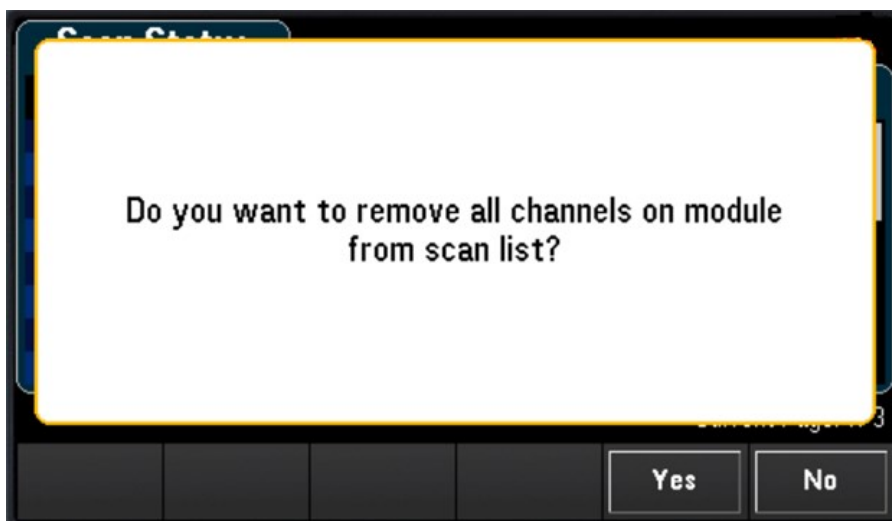

4. Press the **[Channel]** key to return to the Channel menu. Notice the **Open** and **Close** softkeys are now available since the module is now in switch mode. The channel label is maintained. You can press the **Close** softkey to change the channel state.



5. To return to scan mode, press the **Measure** softkey and select a measurement mode. In the example below, TEMP is selected and the module is now back in scan mode. The temperature measurement is restored and the **Open** and **Close** softkey are no longer available.

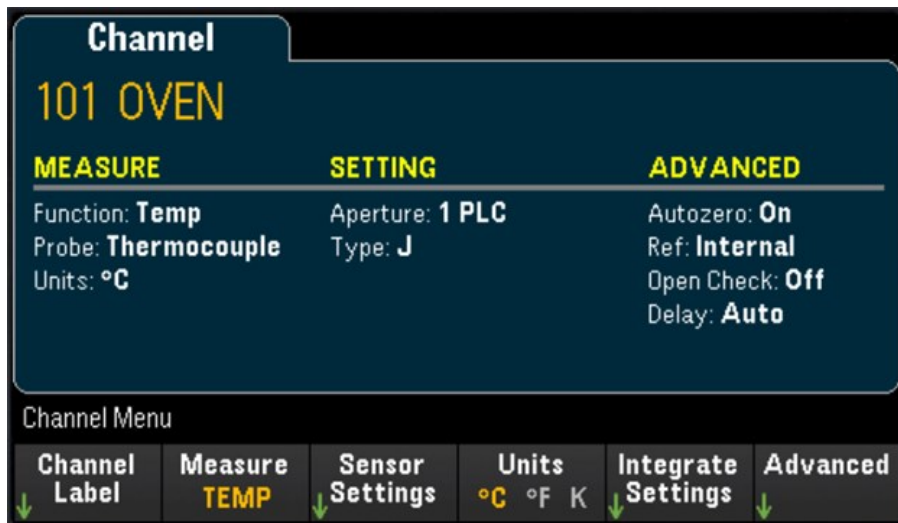

DAQM907A - Multifunction Module

The following section describes how you may configure each of the channels on the DAQM907A. There are total 7 channels available in the DAQM907A multifunction module as shown in the table below:

Channel number	Channel label
01	8-bit Digital I/O Channel
02	8-bit Digital I/O Channel
03	Totalizer Channel
04	DAC Output Channel
05	DAC Output Channel
06	DAC Output Sense Channel
07	DAC Output Sense Channel

Digital I/O (DIO) Channels (Channel 01 and 02)

The DAQM907A multifunction module has two non-isolated 8-bit input/output ports which you can use for reading digital patterns. You can read the live status of the bits on the port or you can configure a scan to include a digital read.

Configure the DIO channel

1. Press **[Module]** and use the knob or the front panel arrow keys to select the slot containing the multifunction module.

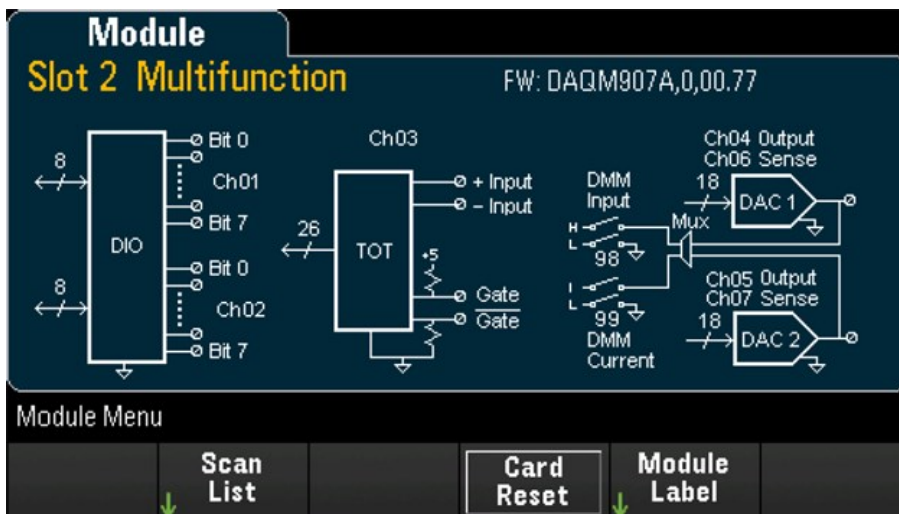

- Press **[Channel]** and use the knob or the front panel arrow keys to select the DIO channels (channel 01 and 02).



- Press **In Scan** to specify whether to include (**On**) or exclude (**Off**) the DIO channel from the scan list.

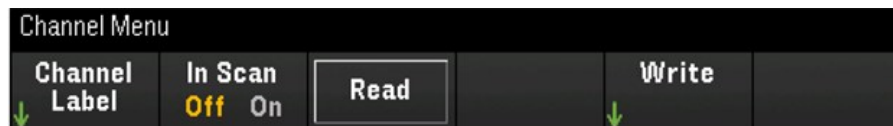

Softkey	Description
Read	Press the Read softkey to read the bit patterns directly from a digital input port.
Write	Press the Write softkey to specify and output the bit pattern to the specified port.

Read a digital input port

Press the **Read** softkey to define the DIO direction as Input.

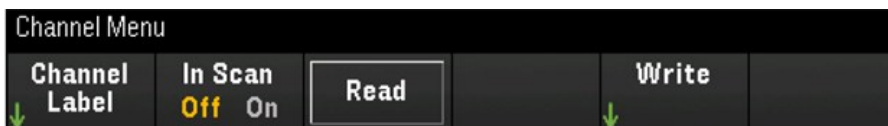

Write to a digital input

1. Press **[Module]** and use the knob or the front panel arrow keys to select the slot containing the multifunction module.

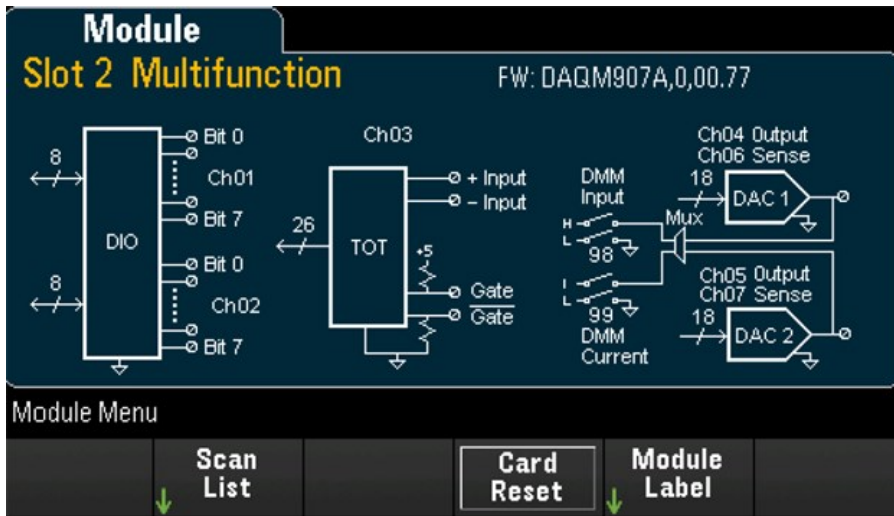

2. Press **[Channel]** and use the knob or the front panel arrow keys to select the DIO channels (channel 01 and 02).



3. Press **Write** > **Base** and use the knob or the front panel arrow keys to select the number base used (**Hex**, **Binary**, or **Decimal**), and then press **Pattern** to define each output pattern from the selected base.



4. Press **Write Pattern** to output the bit pattern on the selected digital output port. The DIO direction will be set to Output.

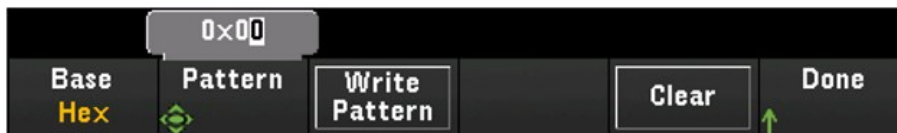

5. Press **Clear** to set the output pattern to "0".

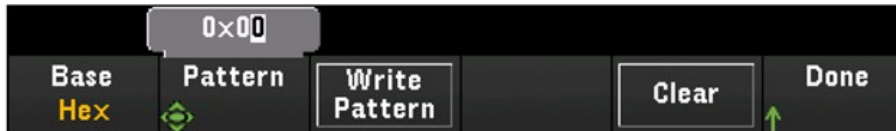

Totalizer Channel

The DAQM907A multifunction module has a 26-bit totalizer which can count TTL-compatible pulses at a 100 kHz rate. The totalizer channel is numbered "s03", where "s" represents the slot number. The totalizer channel is labeled as channel 03.

You can manually read the totalizer count or you can configure a scan to read the count.

To configure the totalizer channel with the multifunction module:

1. Press **[Module]** and use the knob or the front panel arrow keys to select the slot which containing the DAQM907A multifunction module.

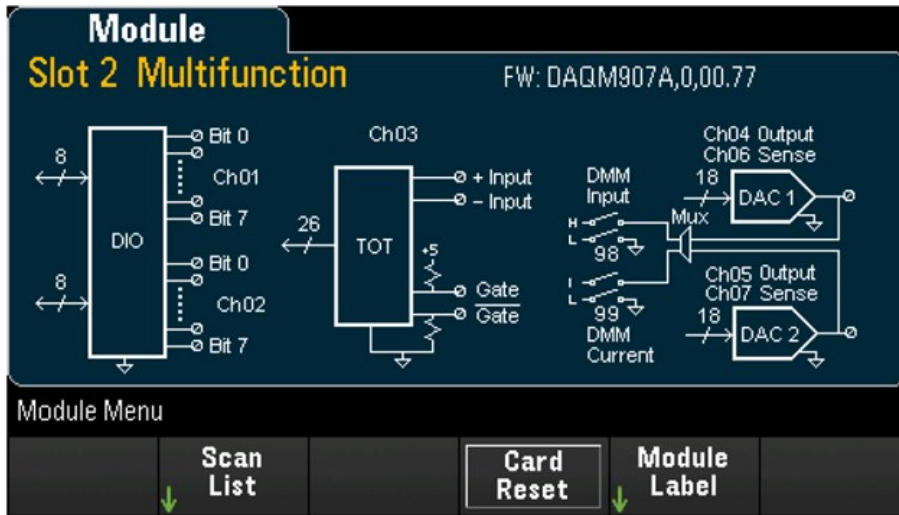

2. Press **[Channel]** and use the knob or the front panel arrow keys to select the totalizer channel (channel 03).



- Press **In Scan** to specify whether to include (**On**) or exclude (**Off**) the totalizer channel from the scan list.

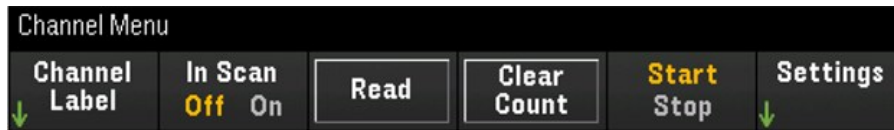

- Press **Settings** > **Edge** to specify if the totalizer channel should count on the rising edge (**Pos**) or falling edge (**Neg**) if the input signal, and then press **ReadReset** to specify if the totalizer count should be automatically reset (**On**) or not (**Off**) when read.

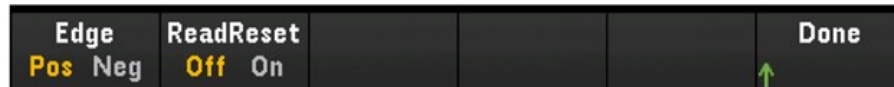

- Press **Read** to read the totalizer count. The count is read once each time you press Read; the count does not update automatically on the display.



- Press **Clear Count** to reset the totalizer count to "0".
- Press the Start/Stop softkey to toggle between **Start** to start the counting on the current totalizer channel, or **Stop** to stop the counting on the current totalizer channel.

DAC output and sense channels (Channels 04 through 07)

The DAQM907A multifunction module has two DAC output channels (channel 04 and 05), and two DAC output sense channels (channel 06 and 07). Any of these channels may be scanned.

For the DAC output channels, no actual output measurement is made; the scanned value will be the programmed output value (voltage or current).

The DAC output sense channels will make a complementary (voltage or current) measurement based on the output mode of the corresponding DAC output channel:

- Channel 06 will make the measurement based on the output mode set in channel 04.
- Channel 07 will make the measurement based on the output mode set in channel 05.

If DAC output channel 04 is set to voltage mode, then the corresponding DAC sense channel 06 will measure current. If the output channel is set to current mode, the sense channel will measure voltage.

1. Press **[Module]** and use the knob or the front panel arrow keys to select the slot containing the multifunction module.

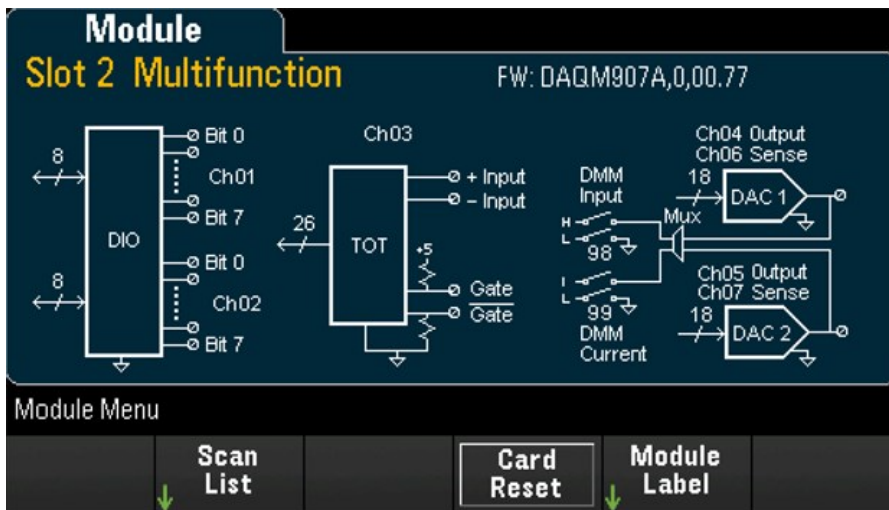

- Press **[Channel]** and use the knob or the front panel arrow keys to select the DAC output channels (channel 04 and 05) or the DAC sense channels (channel 06 and 07).

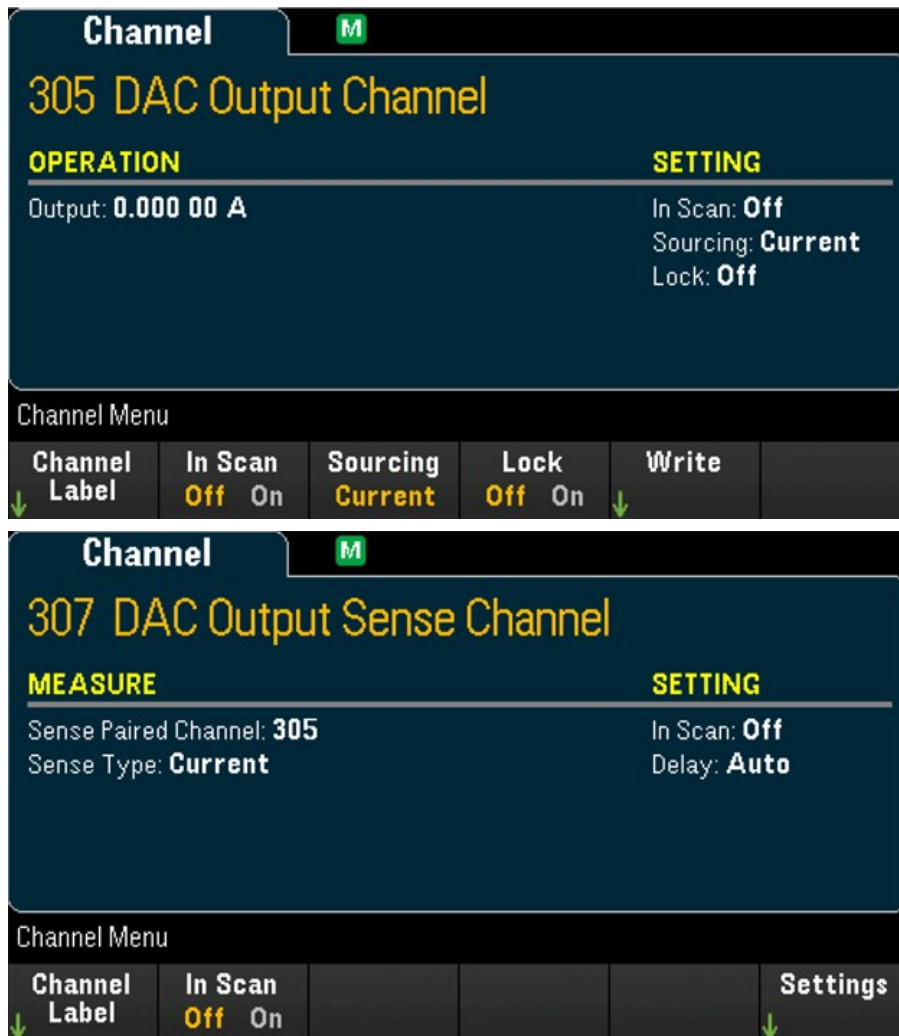

- Press **In Scan** to specify whether to include (On) or exclude (Off) the DAC channel from the scan list.
- Press **Sourcing** to set the output mode in the DAC output channel to **Voltage** or **Current**.
- Toggle **Lock (On)** to lock the DAC output channel mode or toggle **Lock (Off)** to disable the lock on the DAC output channel mode.
- Press **Write > Output** to set the output voltage/current level, and then press **Write Output** to output the voltage/current from the selected DAC output channel.

DAQM909A - 4 Channel 24-Bit Digitizer Module

The DAQM909A can be configured to digitize DC Voltage (DCV) and Strain. The following section describes how you may configure the channels on the DAQM909A.

DC Voltage (DCV)

This section describes how to configure the channels on DAQM909A for DC voltage measurement from the front panel.

1. Connect the voltage source to the module's screw terminals.

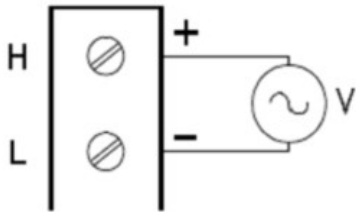

2. Press [Channel] > Measure, and select DCV from the selection menu

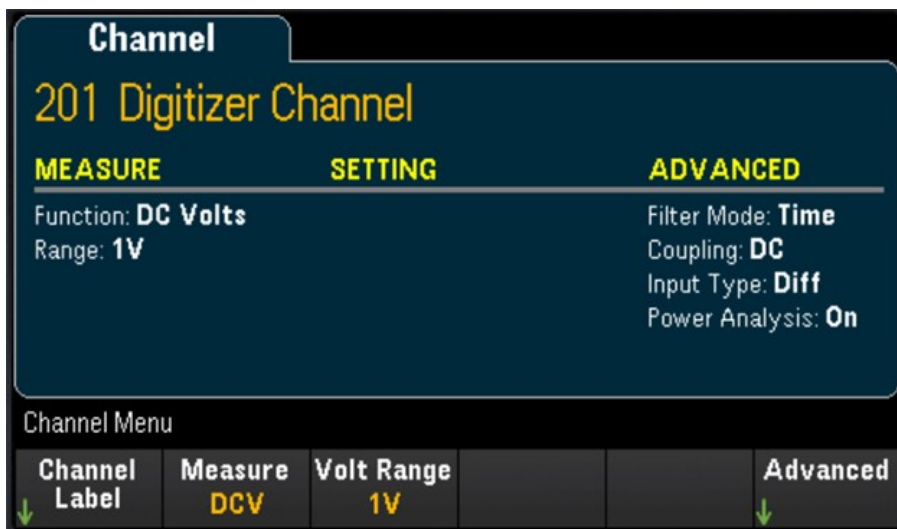

3. Press the **Volt Range** softkey to specify the DC voltage measurement range. You may choose between 300mV, 1 V (default value), 3 V, or 18V.



Advance Settings

Press Advanced to configure the advanced settings for the digitizer.

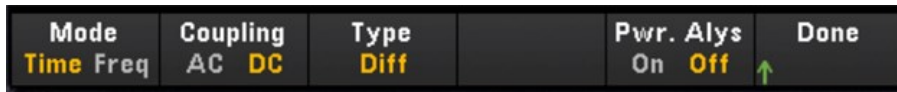

Softkey	Description						
Mode Time/ Freq	Determines the ADC filter mode. Press the Mode softkey to toggle between setting the input in time domain mode (Time) or setting the input in frequency domain mode (Freq). When Time mode is selected, the on board ADC is configured to use the Sinc5 filter. When Freq mode is selected, the onboard ADC is configured to use the Wideband filter.						
Coupling AC/ DC	Press the Coupling softkey to toggle between how the graph is displayed, in AC or DC mode. In AC mode, the AC coupling will display the DC signal that is normalized to a mean of zero. In DC mode, the DC coupling will display the original signal on the screen.						
Type	<table border="1"> <tbody> <tr> <td>Diff</td> <td>Differential (Diff) input measures the input signals from high and low input terminals.</td> </tr> <tr> <td>Send</td> <td>Single Ended (Send) input measures the input signals from high input terminal and grounded low input terminal.</td> </tr> <tr> <td>lepe</td> <td>Integrated Electronics Piezo Electric (lepe) transducer (2-wire IEPE with 100 Ohm LO Ground) measures the input signals with direct current supplied to the high and low input terminals.</td> </tr> </tbody> </table>	Diff	Differential (Diff) input measures the input signals from high and low input terminals.	Send	Single Ended (Send) input measures the input signals from high input terminal and grounded low input terminal.	lepe	Integrated Electronics Piezo Electric (lepe) transducer (2-wire IEPE with 100 Ohm LO Ground) measures the input signals with direct current supplied to the high and low input terminals.
Diff	Differential (Diff) input measures the input signals from high and low input terminals.						
Send	Single Ended (Send) input measures the input signals from high input terminal and grounded low input terminal.						
lepe	Integrated Electronics Piezo Electric (lepe) transducer (2-wire IEPE with 100 Ohm LO Ground) measures the input signals with direct current supplied to the high and low input terminals.						
Pwr. Alys On/ Off	Press the Pwr. Alys softkey to toggle between enabling (On) or disabling (Off) the power analysis feature on the specified channel during data post processing in the View menu.						

NOTE

See **Power Analysis** for further details

Strain

This section describes how to configure the channels on DAQM909A for strain measurement from the front panel.

1. Connect your desired bridge configuration source to the module's screw terminals.

Full bending bridge:

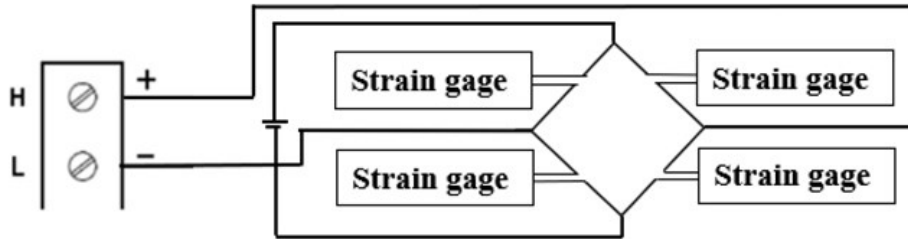

Half bending bridge:

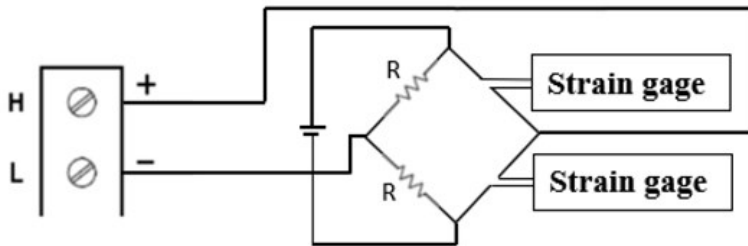

Quarter bridge:

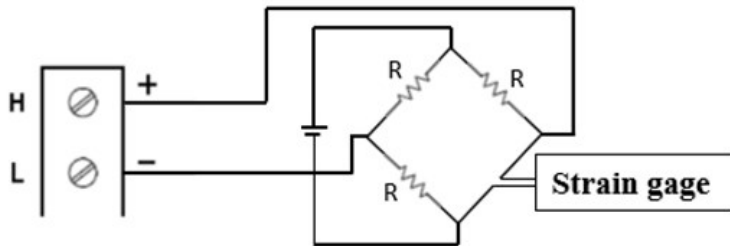

2. Press [Channel] > Measure, and select STRAIN from the selection menu.

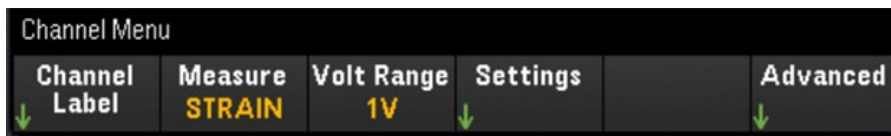

3. Press the **Volt Range** softkey to specify the DC voltage measurement range. You may choose between 300mV, 1 V (default value), 3 V, or 18V.



4. Press **Settings** > **Sense Settings** softkey to specify the strain measurement method based on the bridge configuration which was setup in step 1.

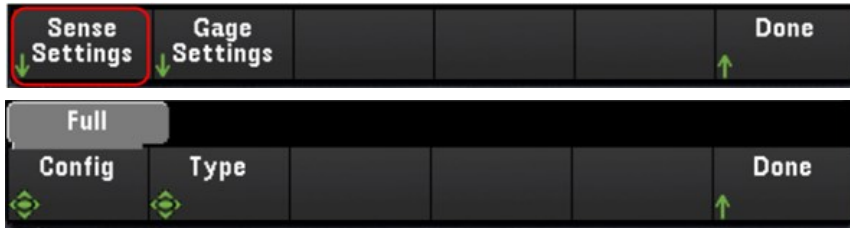

5. Press the **Gage Settings** softkey to specify the various strain gage settings.

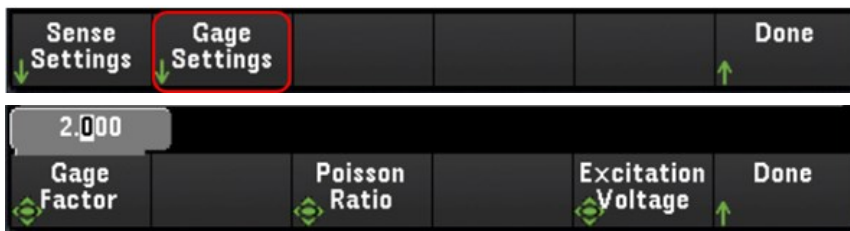

Softkey	Description
Gage Factor	Gage factor is the ratio of the fractional change in resistance to the fractional change in length (strain) along the axis of the gage. The larger the value, the more sensitive strain gage. Gage factor is a dimensionless quantity. The typical value is approximately 2.
Poisson Ratio	Specifies the Poisson ratio of the strain gage. Poisson ratio is defined as the negative ratio of the strain in the transverse direction to the strain in the longitudinal direction.
<div style="display: inline-block; background-color: #cccccc; padding: 5px;">NOTE</div> The Poisson Ratio softkey will only be available when Poisson is specified as the type in the Sense menu.	
Excitation Voltage	Use the knob or the front panel arrow keys to specify the fixed excitation voltage applied to the bridge by an external voltage source. This value will be used to convert strain bridge measurements on the selected channel.

Advance Settings

Press Advanced to configure the advanced settings for the digitizer.

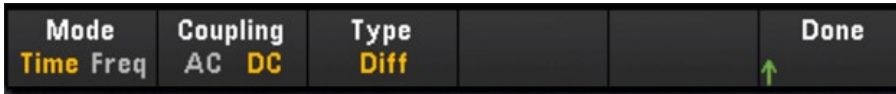

Softkey	Description						
Mode Time/ Freq	Determines the ADC filter mode. Press the Mode softkey to toggle between setting the input in time domain mode (Time) or setting the input in frequency domain mode (Freq). When Time mode is selected, the on board ADC is configured to use the Sinc5 filter. When Freq mode is selected, the onboard ADC is configured to use the Wideband filter.						
Coupling AC/ DC	Press the Coupling softkey to toggle between how the graph is displayed, in AC or DC mode. In AC mode, the AC coupling will display the DC signal that is normalized to a mean of zero. In DC mode, the DC coupling will display the original signal on the screen.						
Type	<table border="1"> <tbody> <tr> <td>Diff</td> <td>Differential (Diff) input measures the input signals from high and low input terminals.</td> </tr> <tr> <td>Send</td> <td>Single Ended (Send) input measures the input signals from high input terminal and grounded low input terminal.</td> </tr> <tr> <td>lepe</td> <td>Integrated Electronics Piezo Electric (lepe) transducer (2-wire IEPE with 100 Ohm LO Ground) measures the input signals with direct current supplied to the high and low input terminals</td> </tr> </tbody> </table>	Diff	Differential (Diff) input measures the input signals from high and low input terminals.	Send	Single Ended (Send) input measures the input signals from high input terminal and grounded low input terminal.	lepe	Integrated Electronics Piezo Electric (lepe) transducer (2-wire IEPE with 100 Ohm LO Ground) measures the input signals with direct current supplied to the high and low input terminals
Diff	Differential (Diff) input measures the input signals from high and low input terminals.						
Send	Single Ended (Send) input measures the input signals from high input terminal and grounded low input terminal.						
lepe	Integrated Electronics Piezo Electric (lepe) transducer (2-wire IEPE with 100 Ohm LO Ground) measures the input signals with direct current supplied to the high and low input terminals						

Computed Channel

A computed channel performs mathematical operations on the readings from measurement channels, or other computed channels. To configure, press **Channel** and use the knob or right arrow key to select one of the computed channels (channels 401 through 420).

NOTE

You must configure the measurement channel(s) before performing the mathematical operations in the computed channel.

Monitoring of computed channels is only available during scanning and will only display the reading from the most recent sweep.

The computed channel is not available when DMM Digitize, or Digitizer is selected as the data acquisition mode.



Press **In Scan** to specify whether the computed channel is included in (**On**) or excluded from (**Off**) the scan list. Press **Equation** to specify the equation to be used for the computed channel. The equations choices can be categorized in three main groups: Basic math, polynomial fifth order, and statistics.

Basic math

Table below shows the supported basic mathematical operations with the respective softkey label.

Operation	Equation softkey label
Addition	A + B
Subtraction	A - B
Multiplication	A * B
Division	A / B
Reciprocal	1 / A
Power	A ²
Square root	Sqrt(A)

For example, to perform the Addition operation from measurement channels (channel 101 and 102) to the computed channel (channel 401):

1. Press **Equation** > **A+B**, use the knob or the front panel arrow keys to specify the **Channel A** softkey to channel 101 and **Channel B** softkey to channel 102.

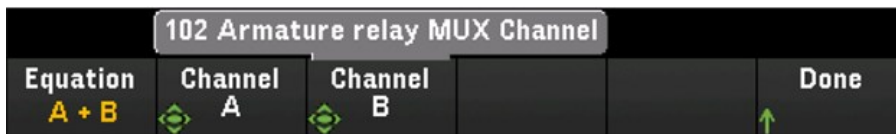

2. Press once on the **[Scan/Start]** key to initiate a scan. You can view the scanned memory readings by pressing **[View]** key. The result of the addition operation from channel 101 and 102 to channel 401 will be displayed as below:

Channel 401 = Channel 101 + Channel 102

Date	Time	Channel	Reading
17/4/2018	11:36:51.664	101 Armature relay...	-148.32 μVDC
17/4/2018	11:36:51.816	102 Armature relay...	-159.01 μVDC
17/4/2018	11:36:51.822	401 Computed Cha...	-307.33 μ

3. Repeat the above steps for the rest of basic math operations (subtract, multiply, etc). If you would like to compute from a single operand channel, set both Channel A and Channel B softkeys to the same channel. The computed readings will be the result of addition readings from the selected channel itself. For example:

Channel 401 = Channel 101 + Channel 101

Date	Time	Channel	Reading
17/4/2018	18:21:48.186	101 Armature relay...	-50.556 μVDC
17/4/2018	18:21:48.186	401 Computed Cha...	-101.11 μ

Polynomial fifth order

To perform this operation from operand channel (channel 101) to the computed channel (channel 401):

1. Press **Equation** > **5th Order**, use the knob or the front panel arrow keys to specify the **Channel A** softkey to channel 101.

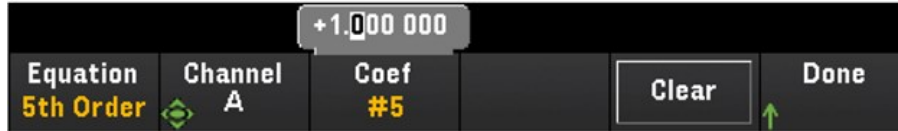

2. Press **Coef** to cycle through the coefficient order (**Coef #5**, **Coef #4**, **Coef #3**, **Coef #2**, **Coef #1**, and **Coef #0**). Specify the coefficient parameters for each coefficient order.
3. Press once on the **[Scan/Start]** key to initiate a scan. You can view the scanned memory readings by pressing **[View]** key. The result of polynomial 5th order will display as below:

Scan Memory			
Date	Time	Channel	Reading
6/19/2019	10:37:22.226	101 Armature relay MU...	19 μ VDC
6/19/2019	10:37:22.310	401 Computed Channel	1.000 02

Statistics

Table below shows the supported statistics operations with the respective softkey label. For statistics, (list) means a set of operand channels that in the computation.

Operation	Statistics softkey label	Description
Average	Avg(list)	Returns the average readings from a list of operand channels, where Average reading = Total sum of all the readings/number of operand channels selected
Maximum	Max(list)	Returns the maximum reading from a list of operand channels
Minimum	Min(list)	Returns the minimum reading from a list of operand channels
Standard deviation	SDev(list)	Returns the standard deviation readings from a list of operand channels
Sum	Sum(list)	Returns the total sum of all readings from a list of operand channels

For example, to perform the Average operation from measurement channels (channels 101 through 103) to the computed channel (channel 401):

1. Press **Equation** > **Avg(list)**, use the knob or the front panel arrow keys to select the operand channels in the **Select** softkey, then press **Add to List** to add the selected operand channel to the operand channel list. Press this softkey repeatedly to add the subsequent operand channel to the operand channel list.



- When the number of operand channel added is reached, the **Remove from List** softkey will appear. Press this key to remove the previous selected operand channel from the operand channel list.



- Press **View List** to display a list of available measurement channels. Currently selected operand channels are marked with an "X". Press **Clear** to remove all selected operand channel from the operand channel list.

Check	Channel	In Scan
[x]	101 Armature relay MUX Channel	Yes
[x]	102 Armature relay MUX Channel	Yes
[x]	103 Armature relay MUX Channel	Yes

- Press once on the **[Scan/Start]** key to initiate a scan. You can view the scanned memory readings by pressing **[View]** key. The result of Average operation will display as below:

$$\text{Channel 401} = (\text{Channel 101} + \text{102} + \text{103}) / 3$$

Date	Time	Channel	Reading
17/4/2018	12:25:47.944	101 Armature relay...	-941,53 μVDC
17/4/2018	12:25:47.996	102 Armature relay...	-1,214.8 mVDC
17/4/2018	12:25:48.048	103 Armature relay...	-1,391.3 mVDC
17/4/2018	12:25:48.049	401 Computed Cha...	-1,182.5 m

NOTE The format for numbers displayed here are Comma as decimal point separator, and thousand separator set to On where period is inserted between every three digits. See [Number Format](#) for details.

You can also include the computed channel as a operand channel in the computed channel list. For example, to include the computed channel 401 from above example to other computed channel (channel 402):

1. Repeat step 1-4 as mentioned above.
2. Press **[Channel]** and use the knob or the front panel arrow keys to set the channel into Channel 402. Press **In Scan** and enables the softkey to include channel 402 in the scan list. Then press **Equation > Avg(list)**, use the knob or the front panel arrow keys to specify the **Channel A** softkey to channel 101 and **Channel B** softkey to 401 computed channel.
3. Press the **[Scan/Start]** key once to initiate a scan. You can view the scanned memory readings by pressing **[View]** key. The result of Average operation will display as below:

$$\text{Channel 402} = (\text{Channel 101} + 102 + 103 + 401) / 4$$

Date	Time	Channel	Reading	
17/4/2018	12:43:47.090	101 Armature relay...	-1,303.0	mVDC
17/4/2018	12:43:47.142	102 Armature relay...	-1,221.3	mVDC
17/4/2018	12:43:47.195	103 Armature relay...	-1,146.8	mVDC
17/4/2018	12:43:47.195	401 Computed Cha...	-1,223.7	m
17/4/2018	12:43:47.195	402 Computed Cha...	-1,223.7	m

Scanning with External Instruments

In this configuration, you can use the DAQ970A/DAQ973A for signal routing or control applications. If you install a multiplexer plug-in module, you can use the DAQ970A/DAQ973A for scanning with an external instrument. You can connect an external instrument (such as a DMM) to the multiplexer COM terminal.

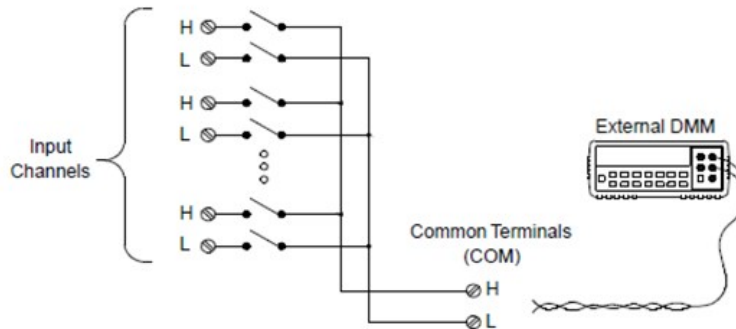

To control scanning with an external instrument, two control lines are provided. When the DAQ970A/DAQ973A and the external instrument are properly configured, you can synchronize a scan sequence between the two.

In this configuration, you must set up a scan list to include all desired multiplexer or multifunction channels. Channels which are not in the scan list are skipped during the scan. The instrument automatically scans the list of channels in ascending order from slot 100 through slot 300.

For an externally-controlled scan, you must disable the internal DMM by pressing **[Home]** > **User Settings** > **DMM Off**. Since the internal DMM is disabled, readings from multiplexer channels are not stored in internal reading memory.

External connections are required to synchronize the scan sequence between the DAQ970A/DAQ973A and the external instrument. The DAQ970A/DAQ973A must notify the external instrument when a relay is closed and settled (including channel delay). The DAQ970A/DAQ973A outputs a Channel Closed pulse from pin 5 on the rear-panel connector. In response, the external instrument must notify the DAQ970A/DAQ973A when it has finished its measurement and ready to advance to the next channel in the scan list. The DAQ970A/DAQ973A accepts a Channel Advance signal on the External Trigger input line (pin 6).

You can configure the event or action that controls the onset of each sweep through the scan list (a sweep is one pass through the scan list). When the DMM is disabled, the default scan interval source is "Auto" (Immediate). For more information, refer to Scan Interval. You can configure the event or action that notifies the DAQ970A/DAQ973A to advance to the next channel in the scan list. Note that the Channel Advance source shares the same sources as the scan interval. However, an error is generated if you attempt to set the channel advance source to the same source used for the scan interval.

You can specify the number of times the instrument will sweep through the scan list. When the specified number of sweeps have occurred, the scan stops.

An externally-controlled scan can also include a read of a digital port or a read of the totalizer count on the multifunction module. When the channel advance reaches the first digit channel, the instrument scans through all the digital channels in that slot and stores the readings in reading memory (only one channel advance signal is required).

You can configure the list of channels for 4-wire external scanning. When enabled, the instrument automatically pairs channel n with channel $n+10$.

Channel Labeling

Press the **Channel Label** softkey to specify a label for current selected channel. Use the knob or the front panel arrow keys to enter the characters into the display. Note that you are only allowed to enter maximum of 10 characters for the module label, including letters, numbers, and special characters. To return into the default channel label, press **Channel Label > Clear All > Done**. This setting is applicable to all modules installed, as well as the computed channels.



[Interval] Menu

Press the **[Interval]** key on the front panel to configure what starts each sweep and the number of sweeps in the scan.

NOTE

The options within the **[Interval]** menu will vary depending on the selected data acquisition mode in the **[Home]** menu (**[Home]** > **Acquire** > **Scan**, **DMM Digitize**, or **Digitizer**).

When you press **[Home]** > **Acquire** > **DMM Digitize**, or **Digitizer**, the **[Interval]** menu will only be available once you have configured the channel(s).

[Interval] menu in Scan mode

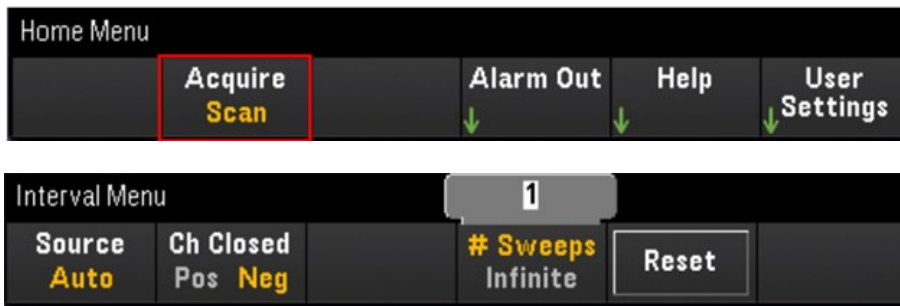

Selecting the trigger source

Press the **Source** softkey to select the trigger source to start a sweep. A sweep is one pass through the scan list.

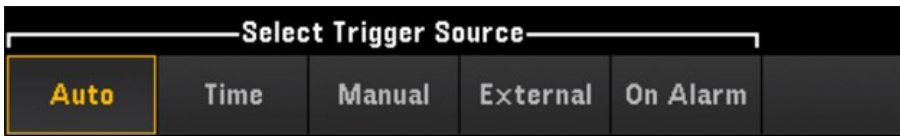

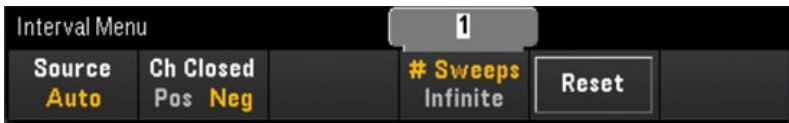
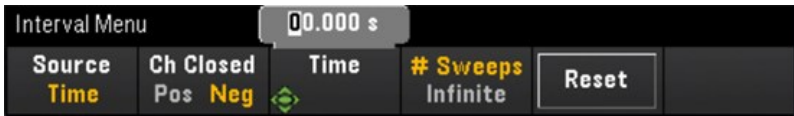
Softkey	Description
Source	<p>Auto</p>  <p>Selects an immediate trigger. When the scan is started, each sweep will start automatically.</p>
Time	<p>00.000 s</p>  <p>Sets the instrument's internal timer to automatically start sweeps at a specific interval. Once you have selected this as the trigger source, press the Time softkey to configure the time interval between 0 seconds and 360,000 seconds (100:00:00 hours).</p>

Manual

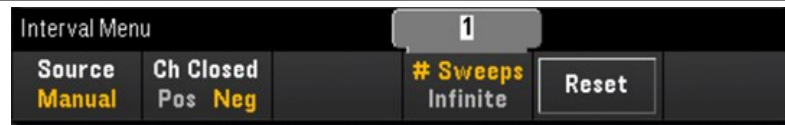

Selects manual trigger. A sweep is started manually by pressing the [Scan/Start] key once on the front panel.

External



Starts a sweep when an external TTL-compatible trigger pulse is received from the Ext Trig/Alarms connector on the rear panel. Once you have selected this as the trigger source, press the **Ext Trig** softkey to specify the polarity of the Ext Trig signal as rising edge (Pos) or falling edge (Neg).

On Alarm

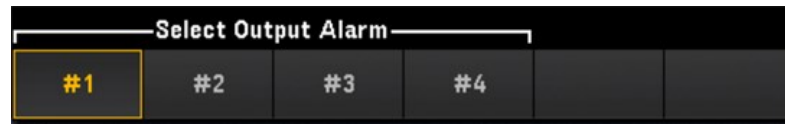
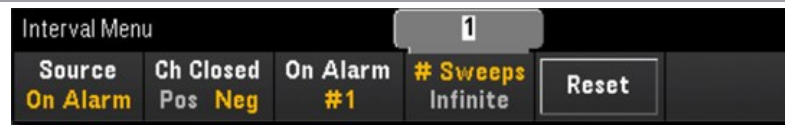

Starts a sweep when an alarm condition is detected during a scan, on the monitor channel, or on a DIO or Totalizer channel. Once you have selected this as the trigger source, press the **On Alarm** softkey to specify which of the four alarms will be used to report alarm conditions on the selected channel.

Selecting the output trigger polarity

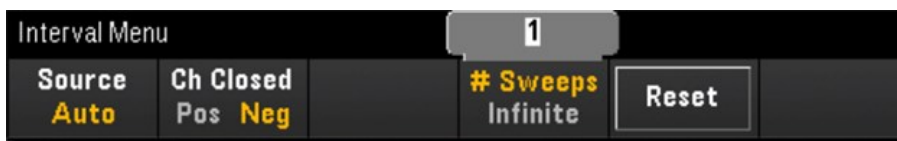

Press **Ch Closed** softkey to select the rising edge (Pos) or falling edge (Neg) as the Chan Closed signal on the rear panel Ext Trig/Alarm connector.

NOTE

The output trigger (channel closed signal) operates differently during internal or external scan.

- For internal scans (internal DMM enabled), it is generated at the END of a sweep, not the beginning of a sweep.
- For external scans (internal DMM disabled), it is generated when each channel is closed, and can be used to trigger the measurement on the external DMM.

Specifying number of sweeps in the scan

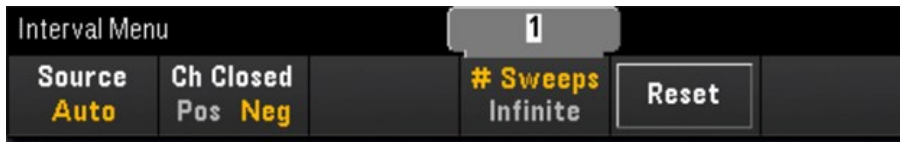

Specifies the number of times that the instrument will sweep through the scan list (**# Sweeps**) or continuous sweeps (**Infinite**).

- **# Sweeps** - Specifies the number of times (between 1 to 1,000,000 sweeps) that the instrument will sweep through the scan list after the scan is started. Press **Reset** to reset the sweep count to 1.
- **Infinite** - Sets a scan to continue indefinitely until manually stopped using the front panel **[Scan/Start]** key, or the SCPI "ABORt" command is sent, or a "Device Clear" message is sent from the remote interface.

The instrument can hold up to 1,000,000 readings in reading memory, after which the **MEM** annunciator will be displayed indicating reading memory overflow. Any new readings will overwrite the first (oldest) readings saved; the most recent readings are always preserved.

[Interval] menu in DMM Digitize mode



Selecting the trigger source

Press the **Source** softkey to select the trigger source.

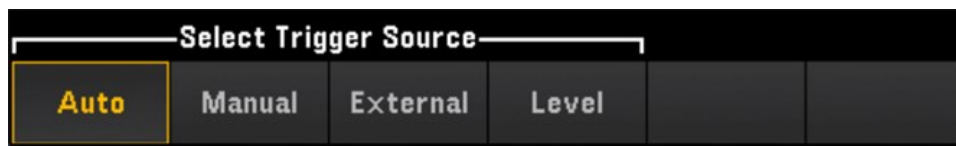

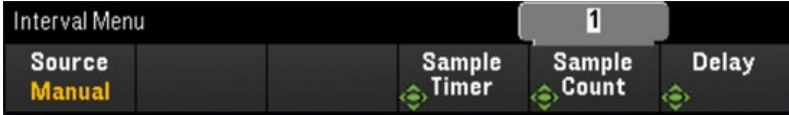
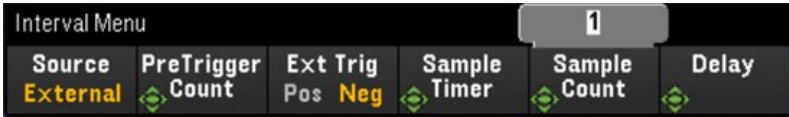
Softkey	Description
Source Auto	 <p>Selects an immediate trigger. The instrument will automatically trigger immediately when the [Scan/Start] key is pressed.</p>
Manual	 <p>The specified channel is triggered by pressing the [Scan/Start] key twice on the front panel. The first time the [Scan/Start] key is pressed, the channel is initialized. The second time the [Scan/Start] key is pressed, the channel is manually triggered and will begin the digitizing operation.</p>
External	 <p>Selects external trigger. The instrument is triggered when an external TTL-compatible trigger pulse is received from the Ext Trig connector on the rear panel. Once you have selected this as the trigger source:</p> <ul style="list-style-type: none"> – You may press the Ext Trig softkey to specify the polarity of the Ext Trig signal as rising edge (Pos) or falling edge (Neg). – You may also press the PreTrigger Count softkey to specify a pretrigger count between 0 to 999,999.

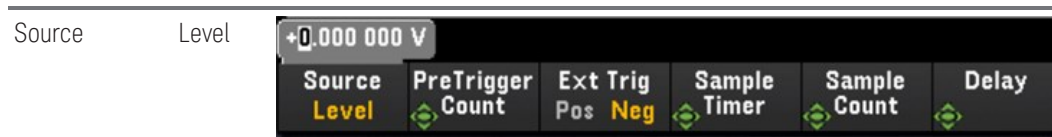

Selects level trigger. The instrument is triggered when the specified measurement threshold condition is met.

- You may press the **Ext Trig** softkey to specify the polarity of the Ext Trig signal as rising edge (**Pos**) or falling edge (**Neg**).
- You may also press the **PreTrigger Count** softkey to specify a pretrigger count between 0 to 999,999.

NOTE

After specifying a pretrigger count, readings are taken and held in a buffer while waiting for the trigger event to occur. When the trigger event occurs, the buffered readings are transferred to reading memory and the remaining readings are recorded as usual. If the trigger event occurs before Pretrigger Count readings have been taken, the trigger event will still take effect and digitizing will complete without having taken all of the pre-trigger readings.

The Pretrigger Count is limited to one less than the total number of readings specified to be taken by the Sample Count setting. If Sample Count = 1, the **Pretrigger** softkey will be hidden.

Specifying the Sample Timer

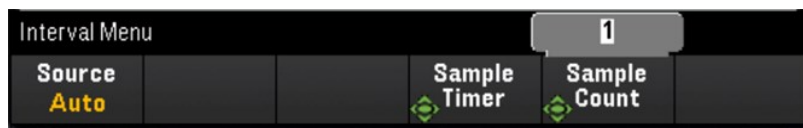

Softkey	Description
Sample Timer	Use the knob or arrow key to specify the sample timer (time between samples) between 20 μ s to 3600 s.

NOTE

This configured value for Sample Timer will remain even though you have changed the channel's measurement function in the **[Channel]** menu.

Specifying the Sample Count

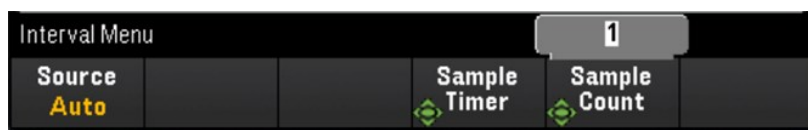

Softkey	Description
Sample Count	Use the knob or arrow key to specify the total number of samples to digitize between 1 sample up to a maximum of 50,331,648 samples.

NOTE

This configured value for Sample Count will remain even though you have changed the channel's measurement function in the **[Channel]** menu.

When Pretrigger Count \neq 0, the instrument will limit the Sample Count to 1,000,000.

Specifying the delay time

Press the **Delay** softkey and use the knob or arrow keys to set a time delay prior to digitizing.

NOTE

The **Delay** option will not be available in these configurations:

- When **Source > Auto** is selected.
 - When a **PreTrigger Count** value is set.
-

[Interval] menu in Digitizer mode.

NOTE

This menu is only available when the DAQM909A module is plugged in.

The interval configurations will be reset to the default values when **Pwr. Alys** (Power Analysis) is enabled in [Channel] menu.

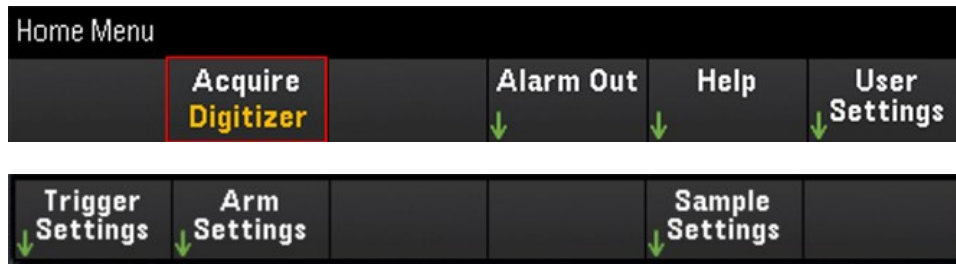

Specifying the Trigger Settings

Press **Trigger Settings** > **Source** softkey to select the trigger source.

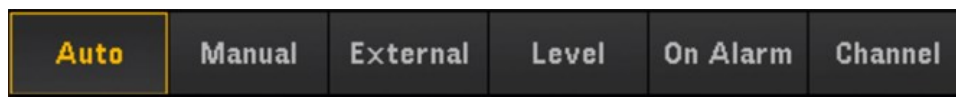

Softkey	Description
Source	<p>Auto</p> <p>The specified digitizer channel will automatically trigger immediately when the [Scan/Start] key is pressed.</p>
Manual	<p>The specified digitizer channel is triggered by pressing the [Scan/Start] key twice on the front panel. The first time the [Scan/Start] key is pressed, the digitizer channel is initialized. The second time the [Scan/Start] key is pressed, the digitizer channel is manually triggered and will begin the digitizing operation. You may press the Delay softkey and use the knob or arrow keys to specify a delay time prior to digitizing.</p>
External	<p>The specified digitizer channel is triggered when an external TTL-compatible trigger pulse is received from the Ext Trig connector on each DAQM909A plug-in module. Once you have selected this as the trigger source, you may press the Ext Trig softkey to specify the polarity of the Ext Trig signal as rising edge (Pos) or falling edge (Neg). You may press the Delay softkey and use the knob or arrow keys to specify a delay time prior to digitizing.</p>

Softkey	Description
---------	-------------

Source	Level	Source Level	Slope Pos Neg		Delay	Done
--------	-------	-----------------	------------------	--	-------	------

The specified digitizer channel is triggered when the input signal crosses the specified trigger level at the specified slope. Once you have selected this as the trigger source, you may press the **Slope** softkey to specify the polarity of the internal trigger signal as rising edge (**Pos**) or falling edge (**Neg**). You may press the **Delay** softkey and use the knob or arrow keys to specify a delay time prior to digitizing.

NOTE

Please refer to Level triggering for more information.

On Alarm	Source On Alarm	On Alarm #1		Delay	Done
----------	--------------------	----------------	--	-------	------

The specified digitizer channel is triggered when an alarm condition is detected. Press the **On Alarm** softkey to specify which of the four alarms will be used to trigger the channel when the alarm conditions are met. You may press the **Delay** softkey and use the knob or arrow keys to specify a delay time prior to digitizing.

Channel	Source Channel			Delay	Done
---------	-------------------	--	--	-------	------

The specified digitizer channel is triggered when its master channel is triggered. Any digitizer channels can be configured and selected as the master channel even the channel is from different module. You may press the **Delay** softkey and use the knob or arrow keys to specify a delay time prior to digitizing.

NOTE

The Channel option will only be available once the conditions below are met:

- One of the digitizer channels must first be configured as the trigger channel before the option of selecting Channel as a source is made available to the rest of the digitizer channels.
- The trigger source of the trigger channel is not set to Auto.

Rules for configuring a trigger channel:

- The trigger source of the trigger channel cannot be set to Auto.
- A digitizer channel cannot select itself as trigger channel.
- A channel can be the trigger master of multiple channels, but a channel cannot have multiple trigger channels.
- When dealing with a chain of trigger channels, a trigger channel cannot be a child channel of another trigger channel in the chain.
- Trigger channel configurations will return to default upon disabling the digitizer channel.

Specifying the Arm Settings

Press the Arm Settings softkey to specify the digitizer's arm settings.



NOTE The **Source** softkey will not be available for configuration when **DMM Digitize** data acquisition mode is enabled on another plug-in module's channel.

Softkey	Description
Source	Auto
	Sweep

NOTE The **Sweep** option will only be available when these plug-in modules are inserted and configured on the instrument: DAQM900A, DAQM901A, DAQM902A, DAQM907A, DAQM908A.

Arm Count Press the **Arm Count** softkey and use the knob or arrow keys to specify the number of Arm Count.

Specifying the Sample Settings

Press the Sample Settings softkey to specify the digitizer's trigger settings.



Softkey	Description
Trigger Settings	Samp Rate

Press the **Samp Rate** softkey to set your desired sampling rate (in Hz). You may choose a sampling rate from the options provided, ranging between 1.5625 KHz to 800 KHz.

NOTE The same configured sampling rate value will be reflected across all channels in the DAQM909A module with the same ADC filter.

Sample Count Press the **Sample Count** softkey and use the knob or arrow keys to specify the number of sample counts.

PreTrigger Count Press the **PreTrigger Count** softkey and use the knob or arrow keys to specify the number of pretrigger count.

NOTE The number of **Pretrigger Count** is limited to one less than the specified number of **Sample Count**.

The **PreTrigger Count** setting will not be available when **Source > Auto** is selected.

NOTE

The instrument allocates a fixed amount of memory for DAQM909A plug-in modules. This memory is equally divided by the total number of digitizer channels available, which is based on the number of DAQM909A module inserted into the instrument.

Since each digitizer channel is allocated with a fixed amount of memory, in your application, you may choose to use up the entire memory for a single record with a maximum sample count, or you may choose to have multiple records with less sample count.

The number of record for a digitizer channel is determined by the specified number of Arm Count. So, in order to get the maximum number of record, set the sample count to minimum.

[Math] Menu

NOTE

The [Math] menu features will not be available when **DMM Digitize**, or **Digitizer** is selected as the data acquisition mode.

You must configure the channel before applying any scaling values.

In the Math menu page, press the **Math** softkey to enable (**On**) or disable (**Off**) measurement scaling.

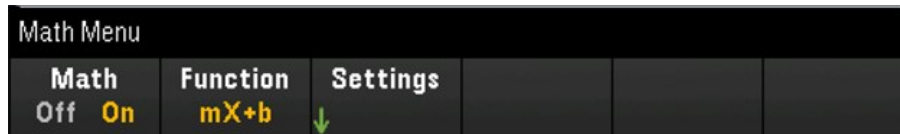

NOTE

Math is set to Off when you change measurement functions (for example, changing from DCV to ACV). You must re-enable math after changing measurement functions.

Press the **Function** softkey to select a scaling function on the selected channel. The **dBm** and **dB** functions are only available on channels configured to measure DC or AC voltage.

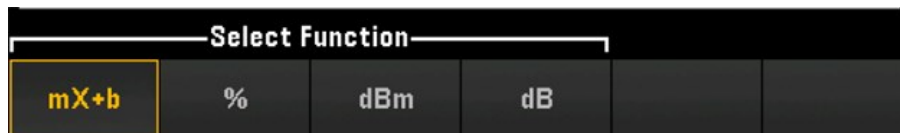

Selects a scaling function and press **Settings** softkey to perform various scaling settings. Scaling values are saved in non-volatile memory for the selected channel.

mX+b Scaling

mX+b scaling function allows you to perform a linear scaling with offset operation, by applying a gain (m) and offset (b) values to all readings on a selected channel during a scan. To configure, select scaling function as **mX+b** and press **Settings** to open the configuration menu.



Softkey	Description
Gain (m)	Use the knob or front panel arrow keys to set the Gain value.
Offset (b)	Use the knob or front panel arrow keys to set the Offset value.
Measure Offset	Press Measure Offset softkey to perform an immediate offset measurement and save the offset value for subsequent measurement.
Clear Offset	Press Clear Offset to clear the offset values to 0.

User Units	User Units On/ Off	Press User Units > User Units Off/On to display (On) or turns off (Off) user-defined measurement units. Selecting On will display unit as defined by the Edit Units softkey; selecting Off will display default units (VDC).
	Edit Units	Press User Units > Edit Units to specify a string containing up to three characters that will be shown in place of the standard measurement units. These units are subsequently used for the entry of various instrument settings such as limits and graph scaling.
	Default Units	Press Default Units to return the unit to the default units for the selected measurement type. For example, if you configure the selected channel as temperature measurement, pressing this softkey will return the default unit into °C.

% Scaling

% performs a percent change operation. The result is the difference between the reading and the reference value, expressed in percentage:

To configure, select scaling function as % and press Settings to open the configuration menu.



Softkey	Description
Ref Value	Use the knob or front panel arrow keys to set the Reference value.
Measure Reference	Press Measure Reference softkey to perform an immediate reference measurement and saves the reference value for subsequent measurements, or press Ref Value softkey to specify the reference value.
Default Reference	Press Default Reference softkey to set the reference value to its factory default settings.

dBm Scaling

Selects dBm scaling for the present measurement function. The result is a calculation of power delivered to a reference resistance (specified using the Ref R softkey), relative to 1 milliwatt.

To configure, select scaling function as **dBm** and press **Settings** to open the configuration menu.

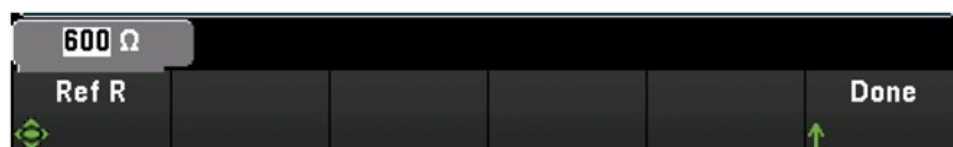

The reference resistance value (Ref R) may be 50, 75, 93, 110, 124, 125, 135, 150, 250, 300, 500, 600 (default), 800, 900, 1000, 1200, or 8000 Ω. Press **Ref R** to specify the reference resistance value for converting voltage measurements to dBm.

dB Scaling

Selects dB scaling for the present measurement function. The result is the difference between the input signal and a stored dB relative reference value, with both values converted to dBm:

To configure, select scaling function as **dB** and press **Settings** to open the configuration menu.



The reference value can be a measurement converted to dBm (**Measure Ref Value** softkey), or you can specify a reference value (**dB Ref Value** softkey). Press **Clear dB Ref** to clear the reference value for dB measurements.

[Copy] Menu

NOTE

Source channel (channel to copy the configuration from) must be included in the scan list before performing this feature.

Copy/paste operation only available for channels with the similar measurement function (for example, from DCV to DCV); where the start channel and end channel are from the similar module slot.

The [Copy] menu features will not be available when **DMM Digitize** is selected as the data acquisition mode.

Press [**Copy**] key on the front panel to copy the measurement configuration from the selected channel(s) to other channel(s). This feature makes it easy to configure several channels for the same measurement. When you copy the configuration from one channel to another, other configuration information such as measurement function, scaling function, alarm configuration, and advanced measurement configurations are automatically copied to other channel(s).

Three options are available:

Copy/paste from a single channel to a single channel (one-to-one)

For example, to copy/paste the measurement configuration from channel 01 to channel 02:

1. Press [**Channel**] and use the knob or the front panel arrow keys to configure channel 01 as DCV (Autorange).

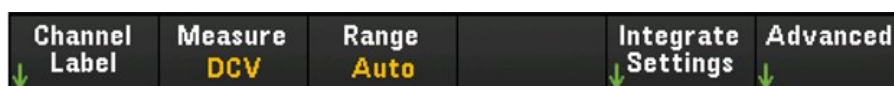

2. Press [**Copy**] > **Source Chan(s)**. Both **Start Channel** and **End Channel** will be displayed with the selected channel 01 as there is no any other configured source channel except this channel. Press **Done** to exit this menu.



3. Press **Dest. Chan(s)** to select the destination channel for the paste operation. The instrument will automatically select the subsequent channel as default choice of destination channel. In this example, use the knob or the front panel arrow keys to determine both **Start Channel** and **End Channel** as channel 02. Press **Done** to proceed.

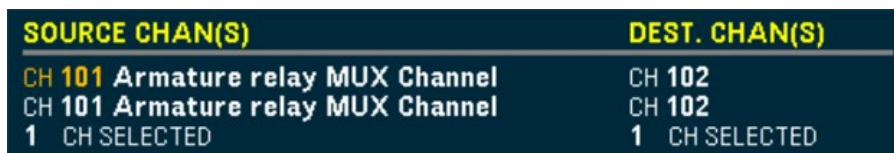

- Press **Copy Now**. The measurement configuration from channel 01 will copy to channel 02. "COMPLETE" message will prompt out at the bottom of the screen when the operation is completed. Press **Copy Now** again to repeatedly copy the same configuration to the new selected channels (channel 03, channel 04, and so on).



Copy/paste from a single channel to multiple channels (one-to-many)

For example, to copy/paste the measurement configuration from channel 01 to channel 02 and 03:

- Press [Channel] and use the knob or the front panel arrow keys to configure channel 01 as DCV (Autorange).
- Press [Copy] > Source Chan(s). Both **Start Channel** and **End Channel** will be displayed with the selected channel 01 as there is no any other configured source channel except this channel. Press **Done** to exit this menu.
- Press **Dest. Chan(s)** to select the destination channel for the paste operation. The instrument will automatically select the subsequent channel as default choice of destination channels. In this example, use the knob or the front panel arrow keys to determine both Start Channel as channel 02 and End Channel as channel 03. Press **Done** to proceed.

SOURCE CHAN(S)	DEST. CHAN(S)
CH 101 Armature relay MUX Channel	CH 102
CH 101 Armature relay MUX Channel	CH 103
1 CH SELECTED	2 CH SELECTED

- Press **Copy Now**. The measurement configuration from channel 01 will copy to both channel 02 and 03. "COMPLETE" message will prompt out when the operation is completed. Press **Copy Now** again to repeatedly copy the same configuration to the new selected channels (channel 04, channel 05, and so on).



Copy/paste from multiple channels to multiple channels (many-to-many)

For example, to copy/paste the measurement configuration from channels 01 through 04 to channels 05 through 08:

1. Press **[Channel]** and use the knob or the front panel arrow keys to configure the source channels as below:
 - Channel 01 and 02 (DCV with Autorange)
 - Channel 03 and 04 (2-wire resistance with the range of 100 Ω)
2. Press **[Copy]** > **Source Chan(s)**. Use the knob or the front panel arrow keys to determine the **Start Channel** as channel 01 while **End Channel** as channel 04. Press **Done** to exit this menu.
3. Press **Dest. Chan(s)** to select the destination channel for the paste operation. The instrument will automatically select the subsequent channel as default choice of destination channels. In this example, use the knob or the front panel arrow keys to determine both **Start Channel** as channel 05.

SOURCE CHAN(S)	DEST. CHAN(S)
CH 101 Armature relay MUX Channel	CH 105
CH 104 Armature relay MUX Channel	CH 108
4 CH SELECTED	4 CH SELECTED

End Channel softkey is unavailable in this option, instrument will automatically perform the copy/paste operation into the next N subsequent destination channels based on the N selected of source channels. For example, if you set the Start Channel as channel 06, destination channels selected will be channels 06 through 09. Press Done to proceed.

SOURCE CHAN(S)	DEST. CHAN(S)
CH 101 Armature relay MUX Channel	CH 106
CH 104 Armature relay MUX Channel	CH 109
4 CH SELECTED	4 CH SELECTED

4. Press **Copy Now**. The measurement configuration from channels 01 through 04 will copy to channels 06 through 09. "COMPLETED" message will prompt out when the operation is completed. Press **Copy Now** again to repeatedly copy the same configuration to the new selected channels (channels 09 through 11, and so on).

Copy M	
Configuration Summary	
SOURCE CHAN(S)	DEST. CHAN(S)
CH 101 Armature relay MUX Channel	CH 110
CH 104 Armature relay MUX Channel	CH 113
4 CH SELECTED	4 CH SELECTED
COMPLETED	

[Alarm] Menu

Press **[Alarm]** key on the front panel to configure alarm on the selected channel. There are four configurable alarms in this instrument. You must configure the channel before setting any alarm limits. If you change the measurement configuration, alarms are turned off and the limit values are cleared. If you plan to use **scaling function** on a channel which will also use alarms, be sure to configure the scaling values first.

NOTE

The [Alarm] menu features will not be available when **DMM Digitize**, or **Digitizer** is selected as the data acquisition mode.

Configuring alarms limits on multiplexer modules

1. In Alarm menu page, press **Output** softkey to select which of the four alarms will be used to report alarm conditions on the selected channel. You can assign multiple channels to any of the four available alarms (numbered 1 through 4).

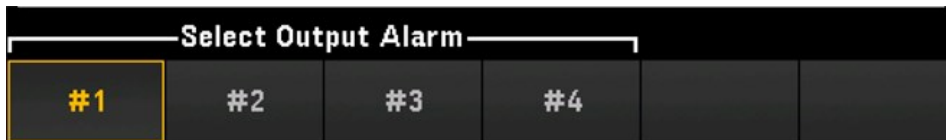

2. Press Alarm to disable (Off) or specify an alarm limit (high, low, or both), and then press **Set Limits** to determine the limit value. The instrument will generate an alarm when a scanned or monitor reading exceeds the specified limit.

Alarm softkey	Set Limits softkey
---------------	--------------------

Off

N/A - Alarm is disabled

High + Low

Specify the limits as high and low values, or as a center value with a span around the center value. Pressing either the 1st or 2nd softkey will toggle between the two options.



High

Specify the upper limit value using the knob or front panel arrow keys. The upper limit value must always be greater than or equal to the lower limit.



Low

Specify the lower limit value using the knob or front panel arrow keys. The lower limit value must always be less than or equal to the upper limit.



3. Press **Clear** to return the limit value to the default value, 0.
4. Press **[Scan/Start]** to initiate the scan and save the readings in reading memory. If an alarm occurs on a channel as it is being scanned, then that channel's alarm status is saved in reading memory as the readings are taken. Each time you start a new scan, the instrument clears all readings (including alarm data) stored in reading memory from the previous scan.
5. As alarms are generated, they are also logged in an alarm queue, which is separated from reading memory. Press **[View] > Alarms** to display the alarm queue.

Configuring alarm limits with the multifunction module

You can configure the DAQM907A multifunction module to generate an alarm when a specific bit pattern or bit pattern change is detected on a digital I/O channels (channel 01 and 02) or when a specific count is reached on a totalizer channel (channel 03).

To configure an alarm on a digital I/O channel

1. On a multifunction module slot, press **[Alarm]** and select the digital I/O channel.
2. Press **Set Pattern > Pattern**, and use the knob or the front panel arrow keys to set the digital mask data for 8-bit digital pattern comparison.



3. Sets each bit to "0", "1", or "X" by pressing the **Set to all 0's**, **Set to all 1's**, or **Set to all X's** softkeys. Bits set to "X" are excluded from the digital pattern comparison.
4. Press **Fail On** to configure the selected channel to generate an alarm when a specific 8-bit pattern read is equal or not equal to the digital data read.

To configure an alarm on a totalizer channel

1. On a multifunction module slot, press **[Alarm]** and select the totalizer channel.
2. Press **Set Limits > Limit Count** to specify the limit count. An alarm will be generated when a specific count is reached during scanning.

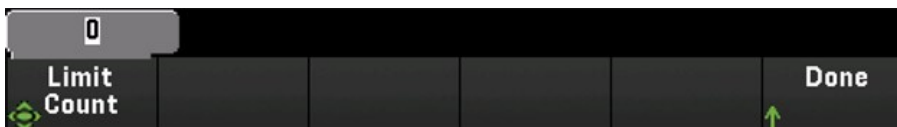

Alarm limit indications

The display uses colors to indicate limits and limit violations.

Number

The bright red color (shown below) indicates that the displayed measurement exceeds the limits.



Bar Meter

The bar meter (below) uses the same color scheme. The following example shows a limit violation. The word FAIL indicates that a limit has been exceeded.

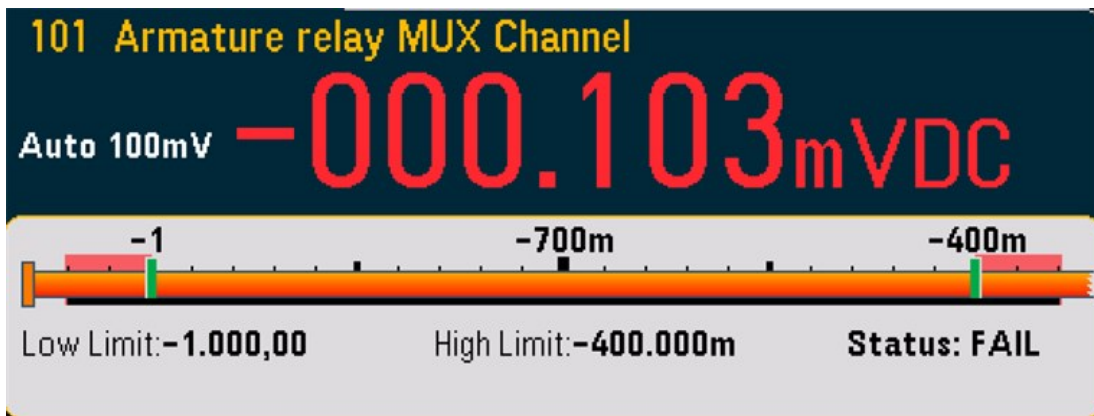

Trend Chart

The trend chart (below) uses the same color scheme. The following example shows a limit violation.

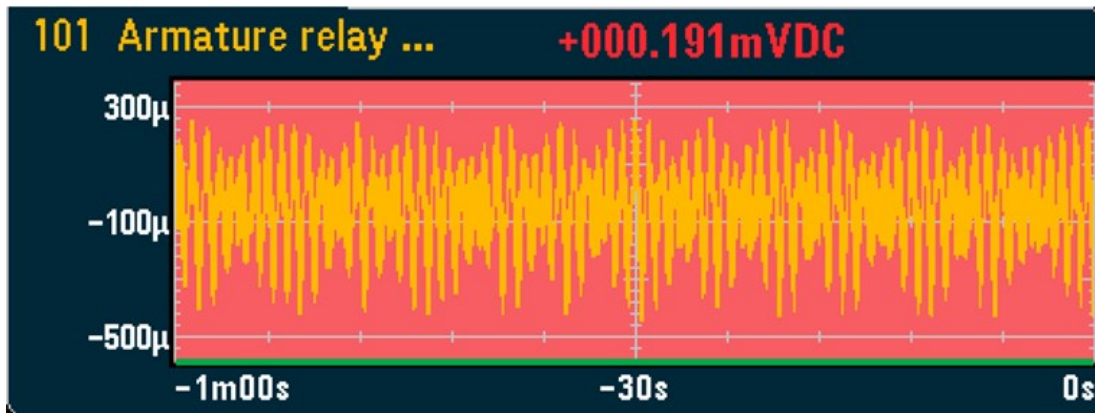

Histogram

The histogram (below) uses the same color scheme. The following example shows a limit violation.

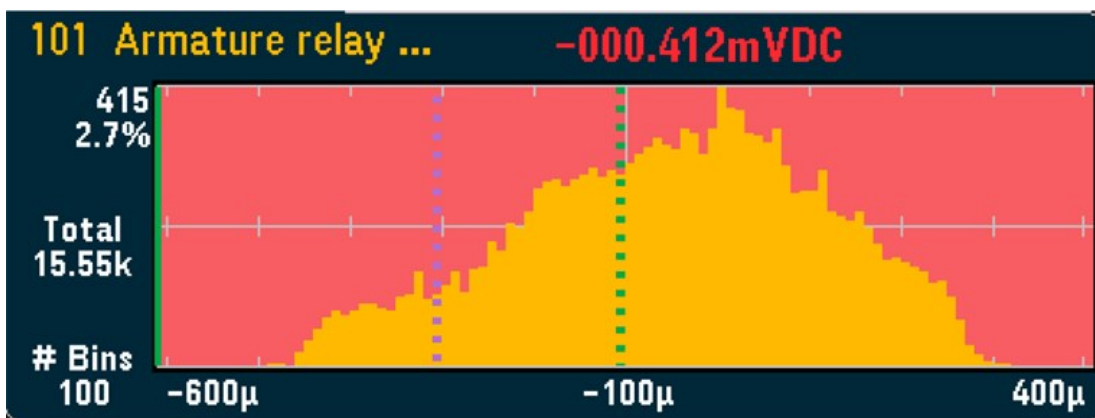

[Utility] Menu



Self Test

Self-test verifies proper instrument operation. See *Keysight DAQ970A/DAQ973A Service Guide* for details about the self-test procedures.

Autocal



Autocalibration

Autocalibration compensates for internal drifts in the internal DMM or on DAQ970A/DAQ973A modules caused by time and temperature change. This can help to eliminate the errors to achieve a better performance. For DAQ970A/DAQ973A, autocalibration is performed on the internal DMM, on the DAC output and sense channels (channels 04 through 07) on the DAQM907A multifunction module, and the DAQM909A Digitizer module.

Softkey	Description
---------	-------------

Perform Autocal To perform autocalibration, press **Perform Autocal** softkey and the screen below will be displayed.

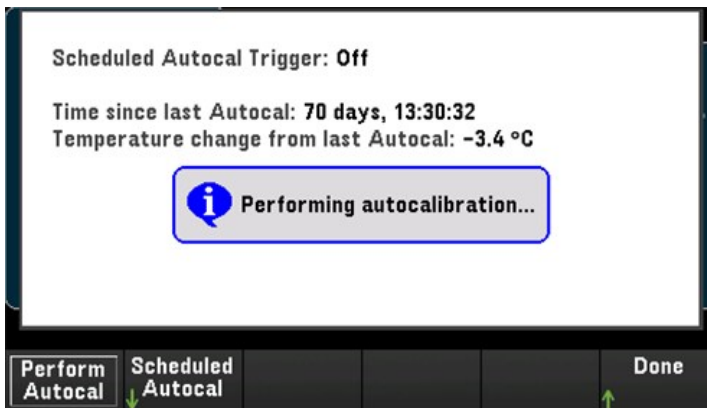

The estimated duration of autocalibration process with the relevant individual module is as below:

Area	Estimated Time (s)	Example of Total Duration Calculation
Internal DMM	~15 seconds	Full autocalibration with 3 x DAQM909A in one mainframe: Internal DMM + (3 x DAQM909A) = ~15 s + (3 x ~20 s) = ~ 75 s
DAQM907A	~ 6 seconds	
DAQM909A	~20 seconds	

Scheduled Autocalibration

You can also schedule the instrument to perform autocalibration based on a scheduled time. To use this feature, press **Scheduled Autocal > Schedule > On**. To specify the frequency, press **Interval > Daily/ Weekly/ Monthly**.

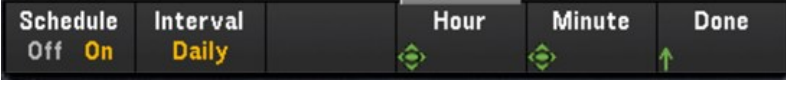
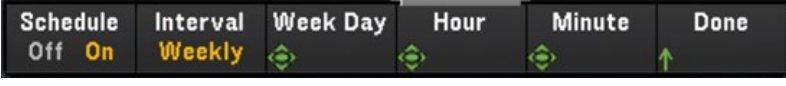
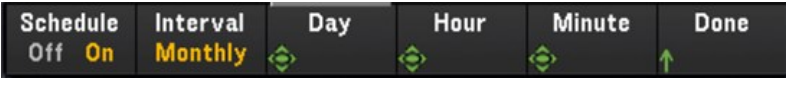
Softkey	Description
Interval	<p>Daily</p>  <ol style="list-style-type: none"> To schedule the instrument to perform daily autocalibration, press Interval > Daily To set the time for daily autocalibration, press the Hour, or the Minute softkeys respectively and use the knob or front panel arrow keys to set your desired time of the day. Once complete, press Done.
	<p>Weekly</p>  <ol style="list-style-type: none"> To schedule the instrument to perform weekly autocalibration, press Interval > Weekly To set the day and time for weekly autocalibration, press the Week Day, the Hour, or the Minute softkeys respectively and use the knob or front panel arrow keys to set your desired day of the week and time of the day. Once complete, press Done.
	<p>Monthly</p>  <ol style="list-style-type: none"> To schedule the instrument to perform monthly autocalibration, press Interval > Monthly To set the day and time for monthly autocalibration, press the Day, the Hour, or the Minute softkeys respectively and use the knob or front panel arrow keys to set your desired day of the month and time of the day. Once complete, press Done.

Calibrate

Calibrate accesses the instrument calibration procedure. See *Keysight DAQ970A/DAQ973A Service Guide* for further details.

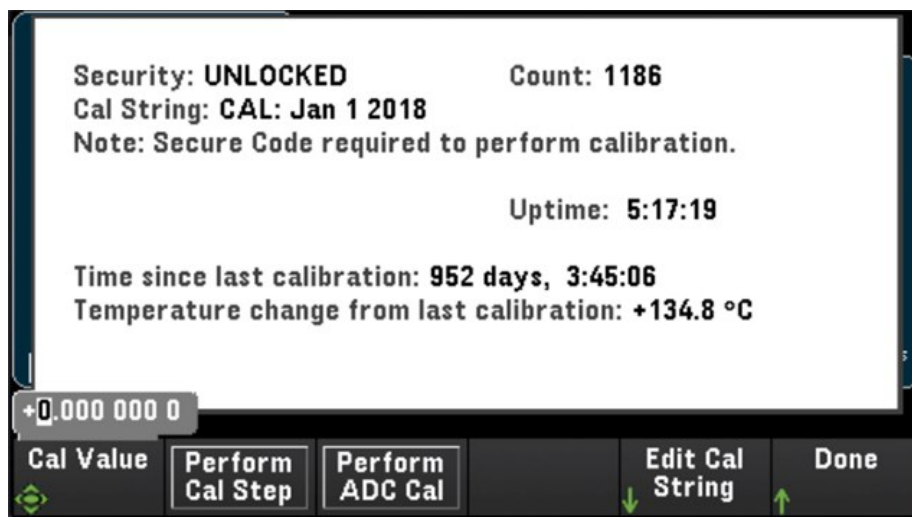

Security

Security shows current instrument security status and enables you to lock or unlock the instrument or enter a new secure code. The instrument must be unlocked to perform calibration, update firmware, or change the secure code.

If Secure Mode is enabled, this shows an overview of instrument I/O settings and provides access to the NISPOM Sanitize function and I/O configuration. The instrument must be unlocked to perform NISPOM Sanitize or to enable or disable I/Os. The Secure Count increments whenever any operation requiring the secure code is performed.



Softkey	Description
New Code	Press the New Code softkey to enter and set a new secure code for unlocking the instrument security. The code must start with a letter and may have up to 12 letters, digits, or the underscore character.
LOCK	Locks instrument security using the current secure code. Secure code is set to "DAQ970A" for both DAQ970A, and DAQ973A models at the factory.
Secure	Toggling the Secure softkey will enable (On) or disable (Off) the instrument security. When On , NISPOM Sanitize softkey will appear and security must be unlocked to make changes to I/O enables and configuration.
NISPOM Sanitize	Press the NISPOM Sanitize softkey to sanitize all user-accessible instrument memory except for the calibration constants. This complies with requirements in chapter 8 of the National Industrial Security Program Operating Manual (NISPOM). When Off, I/O changes can be made without unlocking security.
NOTE The instrument will reboot itself once the sanitization is complete.	

CAUTION

The NISPOM Sanitize softkey and the SYSTEM:SECurity:IMMEdiate command are equivalent. They are for customers, such as military contractors, who must comply with NISPOM.

This feature destroys all user-defined state information, measurement data, and user-defined I/O settings such as the IP address. This feature is not recommended for use in routine applications because of the possibility of unintended data loss.

Admin

Press **Admin** > **Firmware Update** to update the instrument firmware to a new version. See **Firmware Update** for more details.

[Module] Menu

Press the **[Module]** key to access the Module menu. In the Module page, you can view the instrument's scan list, reset the modules, rename the label of a module, and check the relay cycles of the internal DMM and the plug-in modules.

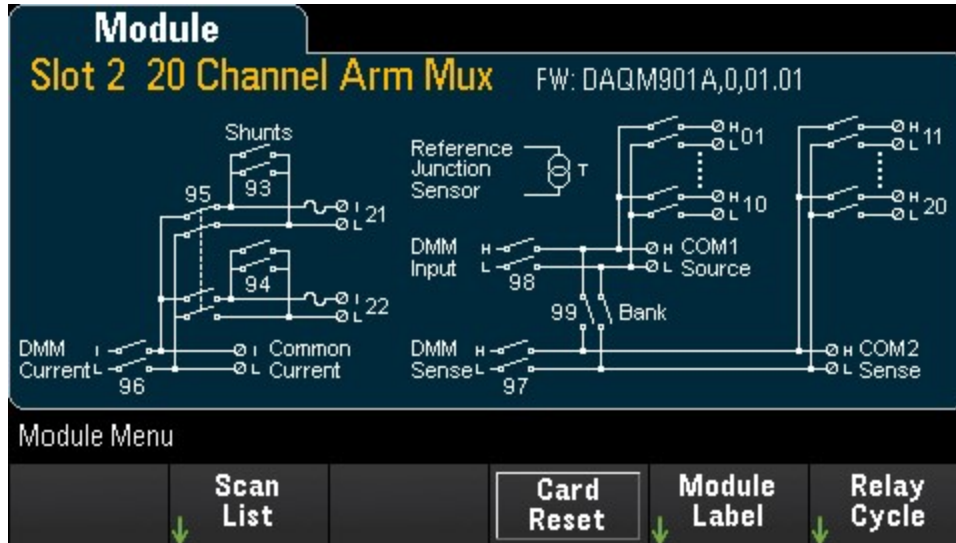

Scan List

NOTE

The options is only available when **Scan** is selected as the data acquisition mode.

Press the **Scan List** softkey to view the available channels on the module that are included in the scan list (Scan Status = ON). Press **Remove From Scan** softkey to turn off measurements on all channels on the module, and remove the channels from the scan list. If the channel list is longer than one page, press the up/down arrow keys on the front panel to scroll through the other pages.

The screenshot displays the **Scan Status** menu. It shows a list of channels and their scan status. The status for all channels is **OFF**. The current page is **1/3**. The bottom of the screen shows the **Remove From Scan** and **Done** softkeys.

Channel	Scan Status
201 Armature relay MUX Channel	OFF
202 Armature relay MUX Channel	OFF
203 Armature relay MUX Channel	OFF
204 Armature relay MUX Channel	OFF
205 Armature relay MUX Channel	OFF
206 Armature relay MUX Channel	OFF
207 Armature relay MUX Channel	OFF
208 Armature relay MUX Channel	OFF

Card Reset

NOTE

The options is only available when **Scan** is selected as the data acquisition mode.

Press the **Card Reset** softkey to reset the module. This opens all the channels on the module. On the multifunction module, this also configures the digital I/O ports as inputs and sets the DAC outputs to voltage mode (if not locked) and the output level to 0.

Module Label

Press Module Label softkey to specify a label for current selected module. Use the knob or the front panel arrow keys to enter the characters into the display. Note that you are only allowed to enter maximum of 10 characters for the module label, including letters, numbers, and special characters. To reset it to the default module label, press **Module Label > Clear All > Done**.



Relay Cycle

Press the **Relay Cycle** softkey to view the number of cycles on each relay in the internal DMM and plug-in modules. Use this feature to track relay failures and predict system maintenance requirements. For more details, see [Relay Life and Preventive Maintenance](#).

Relay Cycles	
Channel	User Cycles
201 Armature relay MUX Channel	6497
202 Armature relay MUX Channel	5609
203 Armature relay MUX Channel	1489
204 Armature relay MUX Channel	1427
205 Armature relay MUX Channel	1079
206 Armature relay MUX Channel	1050
207 Armature relay MUX Channel	797
208 Armature relay MUX Channel	229

Current Page: 1/4

Done

NOTE

To access the Internal DMM page in the **Module** menu, turn the knob counter-clockwise, or press the left arrow key until you see the Internal DMM module page appear. After that, press the Relay Cycle softkey to view the relay cycle of the internal DMM.

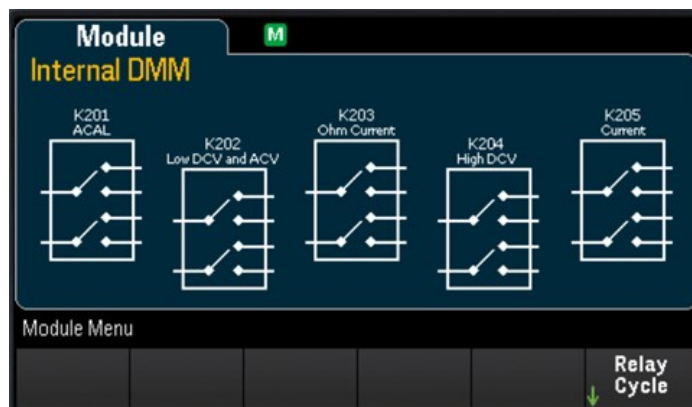

Relay Cycles	
Channel	User Cycles
001 Non-controllable Internal Switch	499
002 Non-controllable Internal Switch	423
003 Non-controllable Internal Switch	487
004 Non-controllable Internal Switch	335
005 Non-controllable Internal Switch	497

Current Page: 1/1

[Save Recall] Menu

Data Acquisition Mode	[Save Recall] menu softkeys
Scan	
DMM Digitize, Digitizer	

Manage Files

The **Manage Files** softkey allows you to create, copy, delete, and rename files and folders in the instrument's internal flash memory or on a USB drive attached to the front panel. Upon pressing the **Manage Files** softkey, the following options will appear:





Softkey	Description
Action:	<ul style="list-style-type: none"> Delete <ol style="list-style-type: none"> 1. To delete a file or folder, press Delete > Browse to navigate the file directory to locate the desired file or folder in the directory. 2. Once the desired file or folder is highlighted, press Select > Perform Delete > Done.
Folder	<ul style="list-style-type: none"> Folder <ol style="list-style-type: none"> 1. To create a new folder, press Folder > Browse to navigate the file directory to the location you wish to create the new folder in. 2. Press File Name, enter your desired folder name and press Done. Press Create Folder > Done
Copy	<ul style="list-style-type: none"> Copy <ol style="list-style-type: none"> 1. To copy a file or folder, press Copy > Browse to navigate the directory to the file or folder you wish to copy and press Select. 2. Press Copy Path and select an internal or external path for copying. Press Perform Copy > Done.
Rename	<ul style="list-style-type: none"> Rename <ol style="list-style-type: none"> 1. To rename a file or folder, press Rename > Browse to navigate the directory to the file or folder you wish to rename and press Select. 2. Press New Name, enter a new name and press Done. Press Perform Rename > Done.
Browse	The Browse softkey opens up the file directory where you can select the file or folder upon which the action will be performed. Use the knob, front panel arrow keys, and [Select] to navigate through the file directory. The left and right arrow keys collapses or expands a folder.
Copy Path	The Copy Path softkey selects an internal or external folder path for copying. Use the knob, front panel arrow keys, and [Select] to navigate through the file directory. The left and right arrow keys collapses or expands a folder.
Perform Copy	The Perform Copy softkey copies the selected file or folder to its new location.

Save

The **Save** softkey allows you to save the instrument's state, user's preferences, and screenshots of the display.

NOTE

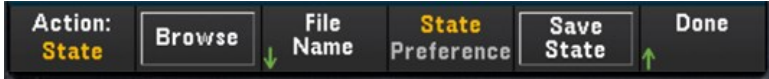
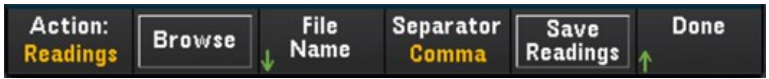
The options on 4th softkey will change in accordance to the option chosen on the [Action:] softkey

Softkey	Description
Action: State	 <p>Saves the current instrument's state or user's preference. The files may have any name, but ends with the (.sta) extension for State files and (.prf) extensions for Preference files respectively. Instrument states saved by the SCPI (*SAV command) are saved in file names STATE_0.sta through STATE_4.sta.</p> <ol style="list-style-type: none"> To save the instrument's state or user's preference, press State > Browse to navigate the file directory to the location you wish to save the file in and press Select. Press File Name, enter a file name and press Done. Press the State/Preference softkey to toggle between saving the current instrument's state (State) or user's preference (Preference). Press the Save State/ Save Preference softkey to save the current instrument's state or user's preference in designated location in the file directory. <p>NOTE State: Saves the measurement configuration including channel configurations and scan settings. Preference: Saves non-volatile settings associated with instrument, including user's preferences and I/O settings.</p>
Readings	 <ol style="list-style-type: none"> To save the measurement readings, press Readings > Browse to navigate the file directory to the location you wish to save the file in and press Select. Press File Name, enter a file name and press Done. Press the Separator softkey to specify the character (Comma, Tab, or Semicolon) which will be used to separate information on each row. Press the Save Readings softkey to save the file in the designated location in the file directory.
Capture	 <ol style="list-style-type: none"> To save a screenshot of the display, press Capture > Browse to navigate the file directory to the location you wish to save the file in and press Select. Press File Name, enter a file name and press Done. Press the Format softkey to specify the image file format (.bmp or .png) to be saved. Press the Save Screen softkey to save the screenshot in the designated location in the file directory.

Browse	The Browse softkey opens up the file directory where you can select the file or folder upon which the action will be performed. Use the knob, front panel arrow keys, and [Select] to navigate through the file directory. The left and right arrow keys collapses or expands a folder.
File Name	The File Name softkey enables you to set the folder or file name for the selected action. To specify a folder or file name, use the knob or the front panel arrow keys to select the desired characters and press [Select] to enter the selected character and move to the next character. When you have finished entering your desired file name, press Done .

Recall

The **Recall** softkey allows you to recall a previously saved state file (.sta extension) or preference file (.prf extension). Use the knob or the front panel arrow keys to browse to a file on internal flash memory (Internal) or the USB drive (External). Use the right arrow key to expand a folder. Press **Select** to recall the selected file.

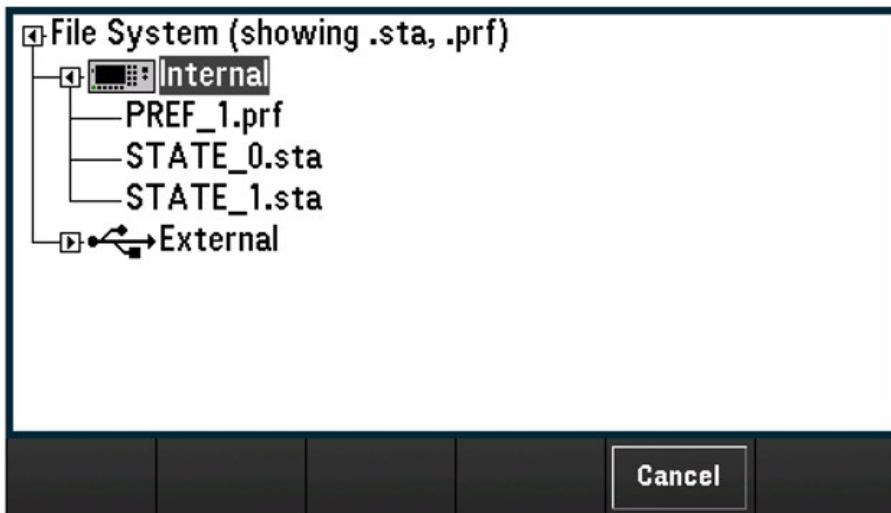

Set to Defaults

The **Set to Defaults** softkey allows you to return the selected settings to their Factory Reset and Preset values. Upon pressing the **Set to Defaults** softkey, the following options will appear:



Softkey	Description
Factory Reset	Resets the instrument to the factory configuration. This softkey will not affect any previously-saved instrument states or I/O settings, such as IP address.
Default Pref	Returns all preferences to default value which includes user preferences and I/O setting which are stored in non-volatile memory
Preset State	Presets the instrument. All readings are cleared and all channels will be open. Channel configurations are unchanged except on multifunction module.

Log to USB

NOTE

The option is only available when **Scan** is selected as the data acquisition mode.

The **Log to USB** softkey allows you to log scanned memory readings to a USB drive connected to the front panel USB host port. The USB annunciator is displayed whenever a USB drive is connected. Upon pressing the **Log to USB** softkey, the following options will appear:

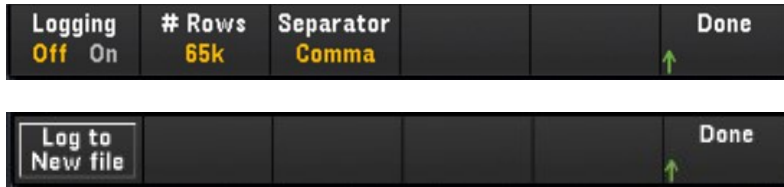

Softkey	Description
Logging	Toggling the Logging softkey will enable (On) or disable (Off) logging of the scanned memory readings to a USB drive connected to the front panel USB host port. When USB data logging is enabled, readings are saved to files in the USB drive. However, the readings will not be restored to reading memory after power is cycled.
# Rows	Pressing the # Rows softkey will allow you to specify the row limit (maximum number of rows for sweep data) that will be written to each data logging file. You may choose from three options: 65k (the limit of each data logging file is 65,536 rows per file), 1M (the limit of each data logging file is 1,048,576 rows per file), or Infinite (the limit is the number of bytes allowed by the file system - up to 4 GBytes or available storage space.)
Separator	Pressing the Separator softkey will allow you to specify the character (Comma , Tab , or Semicolon) to be used for separating the information on each row.
Log to New file	The Log to New file softkey will appear when data logging is in progress. Each time the Log to New file softkey is pressed, it will log the data to a new file.

Folder and file structure

Folder description

Each saved scan will be stored in a top-level folder named:

`/DAQ97xA/[instrument_SN]/[yyyymmdd_hhmmssmmm]`

- The square brackets ([]) are not part of the directory name.
- instrument_SN is the instrument's serial number.
- yyyymmdd_hhmmssmmm is a timestamp indicating the approximate start of the scan. The format is year (yyyy), month (mm), day (dd), underscore (_), hours (hh), minutes (mm), seconds (ss), and milliseconds (mmm).

For example, the folder named: `/DAQ970A/MY00012345/20191127_134523123` would indicate a scan on instrument number MY00012345 started approximately 23.123 seconds after 1:45 pm (13:45) on November 27, 2019.

File description

The top level folder described above will contain two types of files.

1. config.csv

This is a text file that documents the instrument configuration for this scan. The timestamp is as described above. This file lists the configuration of the instrument in a human readable form.

2. dat#####.csv

If you use the command `MMEMemory:FORMat:READing:RLIMit OFF`, all of the data will be stored in one file, named `dat00001.csv`.

You can issue the command `MMEMemory:FORMat:READing:RLIMit ON` to limit the data to 64K - 1 (65,535) sweeps per file, in which case the sweeps are stored in multiple files, named `dat00001.csv`, `dat00002.csv`, `dat00003.csv`, and so on. This is helpful for importing data into spreadsheet or other data analysis software. Note that some spreadsheet or data analysis software may import the data more easily if you change the extension from `csv` to `txt`. If your software does not import the file correctly, try changing the extension on the data file.

Contents of data files

Logging into data files is only supported for channels that are in the scan list. The possible channels are shown in the table below; note that s stands for the slot number, which is 1, 2, or 3.

For example, the DAQM901A module supports could have channels 101-120, 201-220, or 301-320.

Module	Description	Channels
DAQM900A	20-channel FET multiplexer	s01 - s20
DAQM901A	20-channel, 2-wire armature multiplexer	s01 - s20
DAQM902A	16-channel, 2-wire reed multiplexer	s01 - s16
DAQM907A	2-channel DIO input	s01 - s02
DAQM907A	1-channel totalizer, 4-channel DAC	s03, s04 - s27
DAQM908A	40-channel, 1-wire armature multiplexer	s01 - s40

The format for all USB data files is similar to what Keysight BenchLink Data Logger produces by default. The default field separator is a comma, but you can use the **Separator** softkey to specify a different separator.

A sample file is shown below:

Sweep #	Time	Chan 201 (VDC)	Chan 202 (VDC)
1	11/27/2019 08:07:12:237	0.36823663	1.23895216
2	11/27/2019 08:07:13:237	0.62819233	0.98372939
3	11/27/2019 08:07:13:237	0.38238212	0.39382906
4	11/27/2019 08:07:13:237	0.46773299	0.55543345
6	11/27/2019 08:07:13:237	1.32323567	0.21213335

- The channel numbers and the associated units are shown in the header row.
- If the row limit feature is ON and the data spills over into multiple files, scan numbering continues where it left off in the previous file. Thus, the first scan in the second data file would be number 65,536, the first scan in the third data file would be number 131,071, and so on.

Save to USB

NOTE

This option is only available when **DMM Digitize**, or **Digitizer** is selected as the data acquisition mode.

The **Save to USB** softkey similarly allows you to save digitized data to a USB drive connected to the front panel USB host port. The USB annunciator is displayed whenever a USB drive is connected. Upon pressing the **Save to USB** softkey, the following options will appear:

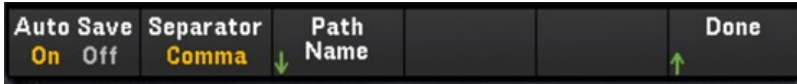

Softkey	Description
Auto Save On/Off	<p>Pressing the Auto Save softkey will enable (On) or disable (Off) the instrument from saving the digitized data to a USB drive connected to the front panel USB host port. If Auto Save is enabled, the instrument will begin saving the data file into the USB drive when the digitizer operation is complete.</p> <p>NOTE If the instrument does not detect a USB drive, it will prevent the instrument from initiating a digitizing process until a USB drive is detected or the Auto Save function is disabled.</p> <p>You may start viewing the results in the [View] menu while the Auto Save operation is running in the background.</p>
Separator	<p>Pressing the Separator softkey will allow you to specify the character (Comma, Tab, or Semicolon) to be used for separating the information on each row in the data file.</p> <p>NOTE This setting is only available when DMM Digitize is selected as the data acquisition mode.</p>
Path Name	<p>Selects a location or folder within the USB drive to save the digitized data.</p> <p>Press the Browse softkey and use the knob or arrow keys to select your desired save location. After that, press the File Name softkey to specify your desired file name. Press Done to complete the process.</p>



NOTE

After every digitizer operation, the new set of data will be written into the same file specified in the Path Name setting; overwriting the old data. Therefore, if you would like to save different sets of data from different digitizing operations, you would need to select a different file in the save path each time before you initiate the digitizer.

Save to USB file format

In **Digitizer** mode, all data files are saved in **.dat** file format when saved into the USB drive. The **.dat** file extension suffix is fixed and cannot be changed.

In **DMM Digitize** mode, by default, all data files are saved in **.csv** file format. However, you may choose to save the data file with a **.dat** filename extension. You may do so by including **.dat** at the end of the file name when you are naming the file.

Save to USB front panel display

The front panel display will have indicators on the screen to inform you that the auto saving operation is in progress. These indicators (highlighted in red) are shown in the images below:

DMM Digitize data acquisition mode:



Digitizer data acquisition mode:

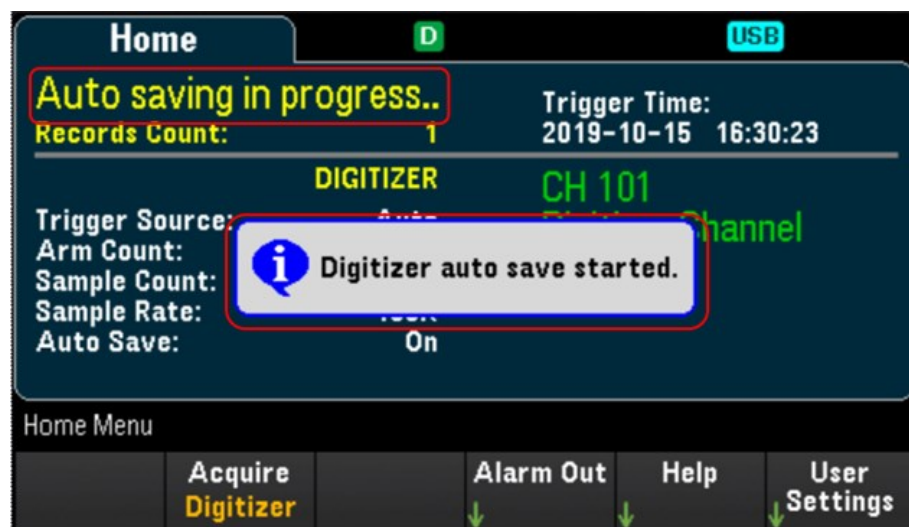

Web Interface

The Keysight DAQ970A/DAQ973A Data Acquisition System include a built-in Web Interface for monitoring and controlling the instrument via a Web browser.

Two available options to access the Web Interface:

- **LAN Interface:** Connect your instrument to the LAN interface and enter the instrument's IP address into the address bar at the top of your PC's Web browser.
- **Keysight IO Libraries Suite:** Select the instrument in Connection Expert and click the Web UI button. Ensure that the Keysight IO Libraries Suite is installed before you proceed for the remote interface configuration.

NOTE

The following is a high-level overview of the Web Interface tabs shown on top of the Web Interface window. When using the Web Interface, open a particular tab, and then click the help button (?) to view help contents for that tab.

Home page

The Home Page displays basic instrument information. Click More Information or Less Information to toggle display of LAN details and LXI compliance information. To change any of the information displayed on this page, use the Control Instrument Page .

KEYSIGHT DAQ970A Data Acquisition System
TECHNOLOGIES Serial number: PROTO00010

Home Control Instrument Configure LAN

Connected to DAQ970A Data Acquisition System
at IP address 10.116.33.101

Enable front panel identification indicator

Description

Model number	DAQ970A Data Acquisition System
Manufacturer	Keysight Technologies
Serial number	PROTO00010
Firmware revision	A.00.2172-01.00-01.73-00.02-01.02-02-01
Description	Keysight DAQ970A Data Acquisition System - PROTO00010

VISA instrument addresses

HISLIP LAN protocol	TCPIP::K-DAQ970A-0010.png.is.keysight.com::hislip0::INSTR
VXI-11 LAN protocol	TCPIP::K-DAQ970A-0010.png.is.keysight.com::inst0::INSTR
TCP/IP SOCKET protocol	TCPIP::K-DAQ970A-0010.png.is.keysight.com::5025::SOCKET
USB (USB7MC/488)	USB::10893::9223::PROTO00010::0::INSTR

More Information

© 2017 Keysight Technologies, Inc. | Support | Products | Keysight

Check the "Enable front panel identification indicator" checkbox to enable a visual indicator that identifies the DAQ970A/DAQ973A. This can help you physically locate the instrument in a rack, for example.

The indicator position and type can vary. Common indicators are LEDs, an onscreen message, or a message displayed in a dialog box. Uncheck the checkbox to turn off the indicator.

Control Instrument page

KEYSIGHT DAQ970A Data Acquisition System
Serial number: PROTO00010

Home Control Instrument Configure LAN

KEYSIGHT DAQ970A Data Acquisition System

Home

Next Sweep: Stopped
Sweep Count: 0
Start Time: N/A

Scan List

Interval: 00:00:00
Count: 1
Log to USB: No

CH 101
Armature relay MUX...
OPEN

Home Menu

Acquire Scan Alarm Out Help User Settings

Note:

- Power Button is not accessible from this remote control interface

© 2017 Keysight Technologies, Inc. | Support | Products | Keysight

Configure LAN page

KEYSIGHT DAQ970A Data Acquisition System
Serial number: PROTO00010

Home Control Instrument Configure LAN

Configure LAN

Current LAN configuration of the instrument

IP Address Configuration	Automatic
IP Address	10.116.33.101
Subnet Mask	255.255.254.0
Default Gateway	10.116.32.1
DNS Server(s)	141.183.230.30 141.183.236.41
Desired Hostname	K-DAQ970A-0010
Domain	png.is.keysight.com
Description	Keysight DAQ970A Data Acquisition System - PROTO00010
Desired mDNS service name	

Edit

Advanced options

© 2017 Keysight Technologies, Inc. | Support | Products | Keysight

Click **Edit** button to edit network configuration page.

When done, click **Apply Changes** to accept new settings or click **Cancel** to ignore changes.

Click **Advanced options** button to reset network configuration options.

Help page

Help is available for each of the tabs described above. For example:

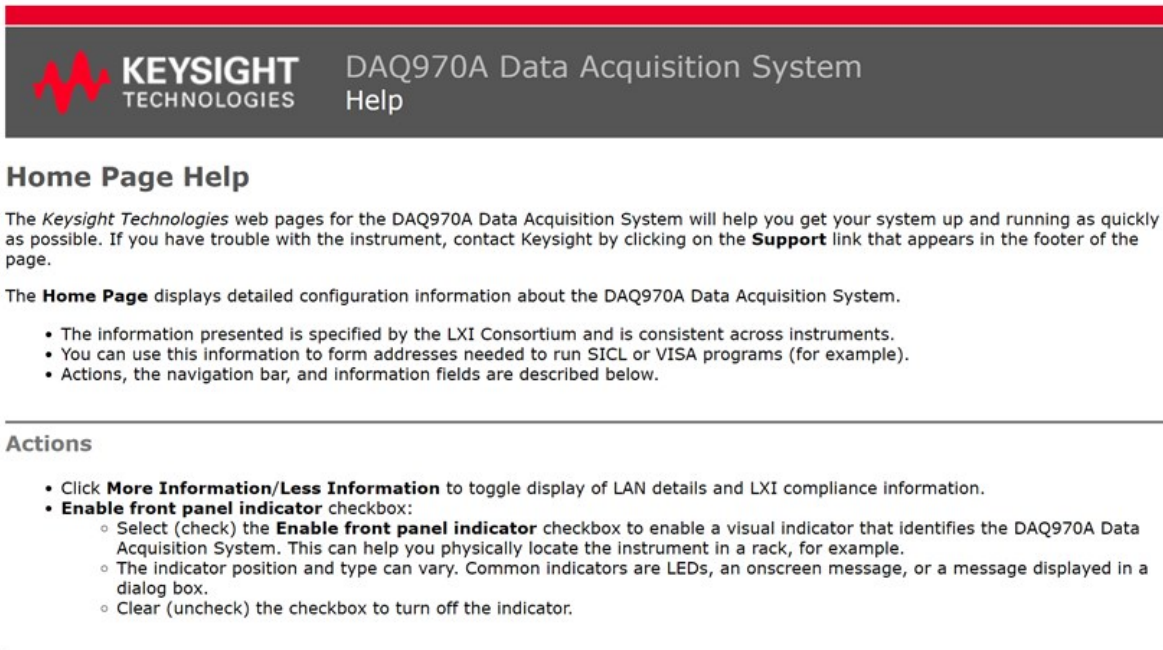

KEYSIGHT
TECHNOLOGIES

DAQ970A Data Acquisition System
Help

Home Page Help

The *Keysight Technologies* web pages for the DAQ970A Data Acquisition System will help you get your system up and running as quickly as possible. If you have trouble with the instrument, contact Keysight by clicking on the **Support** link that appears in the footer of the page.

The **Home Page** displays detailed configuration information about the DAQ970A Data Acquisition System.

- The information presented is specified by the LXI Consortium and is consistent across instruments.
- You can use this information to form addresses needed to run SIDL or VISA programs (for example).
- Actions, the navigation bar, and information fields are described below.

Actions

- Click **More Information/Less Information** to toggle display of LAN details and LXI compliance information.
- **Enable front panel indicator** checkbox:
 - Select (check) the **Enable front panel indicator** checkbox to enable a visual indicator that identifies the DAQ970A Data Acquisition System. This can help you physically locate the instrument in a rack, for example.
 - The indicator position and type can vary. Common indicators are LEDs, an onscreen message, or a message displayed in a dialog box.
 - Clear (uncheck) the checkbox to turn off the indicator.

Module Overview

This section gives a description of each plug-in module, including simplified schematics and block diagrams. A wiring log is also included to make it easy to document your wiring configuration for each module.

- [DAQM900A 20-Channel FET Multiplexer Module](#)
- [DAQM901A 20-Channel Armature Multiplexer Module](#)
- [DAQM902A 16-Channel Reed Multiplexer Module](#)
- [DAQM903A 20-Channel Actuator/General-Purpose Switch Module](#)
- [DAQM904A 4x8 Two-Wire Matrix Switch](#)
- [DAQM905A Dual 1:4 RF Multiplexer \(50 \$\Omega\$ \) Module](#)
- [DAQM907A Multifunction Module](#)
- [DAQM908A 40-channel Single-ended Multiplexer](#)
- [DAQM909A 4-Channel 24-Bit Digitizer Module](#)

DAQM900A 20-Channel FET Multiplexer Module

This module is divided into two banks of 10 two-wire channels each. All 20 channels switch both HI and LO inputs, thus providing fully isolated inputs to the internal DMM or an external instrument. During 4-wire resistance measurements, channels from Bank A (channel n) are automatically paired with channels from Bank B (channel $n+10$) to provide the source and sense connections. The module has a built-in thermocouple reference junction to minimize errors due to thermal gradients when measuring thermocouples.

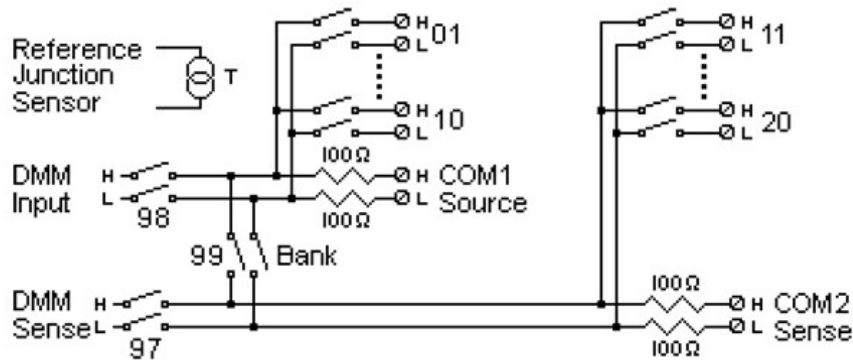

WARNING

TO PREVENT ELECTRICAL SHOCK

To prevent electrical shock, use only wire that is rated for the highest voltage to any channel. Before removing a module cover, turn off all power to external devices connected to the module.

CAUTION WITH MULTIPLE SIGNALS

To avoid the possibility of multiple signal sources becoming connected together, we recommend when multiplexing two or more sources they should be connected on separate modules or on separate banks of the same module.

CAUTION WITH HAZARDOUS VOLTAGES

When any channel is connected to a hazardous voltage source, all channels in the module should be treated as hazardous and all channel wiring in the module should be rated for the maximum voltage applied. Thermocouples attached to any other channel on the module should have insulation rated for the maximum voltage, or have additional insulation added rated for the maximum voltage and should be isolated from conductive parts using a thermal compound or tape rated for the maximum voltage applied. Do not mount, move, or remove any thermocouples when the device under test is connected to a supply source.

ENVIRONMENTAL HEALTH AND SAFETY

When any channel is connected to a hazardous voltage source, the instrument and the device under test should be supervised, following local EHS practices to restrict access.

DAQM901A 20-Channel Armature Multiplexer Module

This module is divided into two banks of 10 two-wire channels each. Two additional fused channels are available on the module (total in 22 channels) for making direct, calibrated DC or AC current measurements with the internal DMM (external shunts resistors are not required). All 22 channels switch both HI and LO inputs, thus providing fully isolated inputs to the internal DMM or an external instrument. During 4-wire resistance measurements, channels from Bank A (channel n) are automatically paired with channels from Bank B (channel $n+10$) to provide the source and sense connections. The module has a built-in thermocouple reference junction to minimize errors due to thermal gradients when measuring thermocouples.

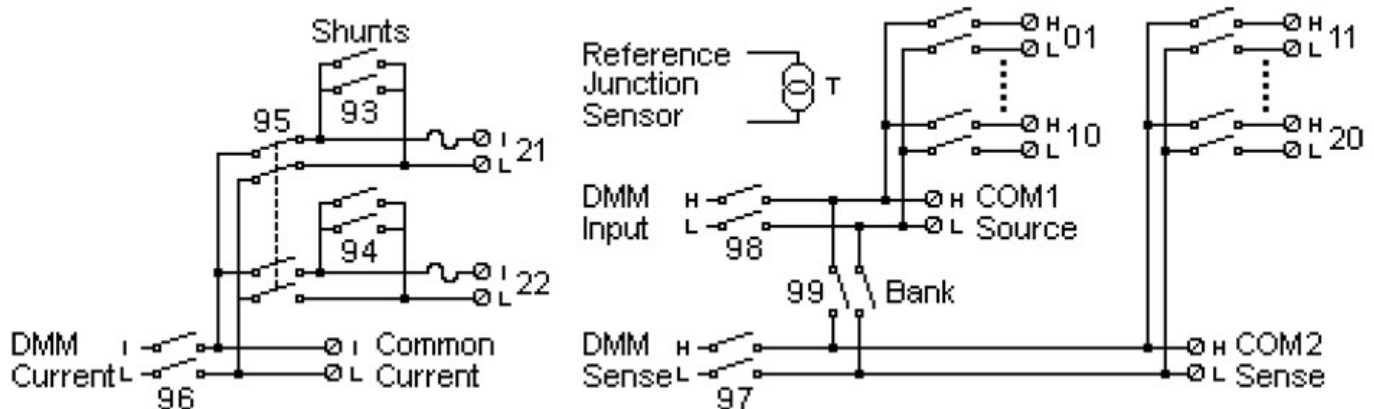

NOTE

Only one of channels 21 and 22 can be connected to the internal DMM and/or COM at a time; connecting one channel will close the other (thus shorting the input "I" to "LO").

WARNING

TO PREVENT ELECTRICAL SHOCK

To prevent electrical shock, use only wire that is rated for the highest voltage to any channel. Before removing a module cover, turn off all power to external devices connected to the module.

CAUTION WITH MULTIPLE SIGNALS

To avoid the possibility of multiple signal sources becoming connected together, we recommend when multiplexing two or more sources they should be connected on separate modules or on separate banks of the same module.

CAUTION WITH HAZARDOUS VOLTAGES

When any channel is connected to a hazardous voltage source, all channels in the module should be treated as hazardous and all channel wiring in the module should be rated for the maximum voltage applied. Thermocouples attached to any other channel on the module should have insulation rated for the maximum voltage, or have additional insulation added rated for the maximum voltage and should be isolated from conductive parts using a thermal compound or tape rated for the maximum voltage applied. Do not mount, move, or remove any thermocouples when the device under test is connected to a supply source.

ENVIRONMENTAL HEALTH AND SAFETY

When any channel is connected to a hazardous voltage source, the instrument and the device under test should be supervised, following local EHS practices to restrict access.

DAQM902A 16-Channel Reed Multiplexer Module

This module is divided into two banks of 8 two-wire channels each. Use this module for those applications that require high-speed scanning and high-throughput in automated test. All 16 channels switch both HI and LO inputs, thus providing fully isolated inputs to the internal DMM or an external instrument. During 4-wire resistance measurements, channels from Bank A (channel n) are automatically paired with channels from Bank B (channel n+8) to provide the source and sense connections. The module has a built-in thermocouple reference junction to minimize errors due to thermal gradients when measuring thermocouples.

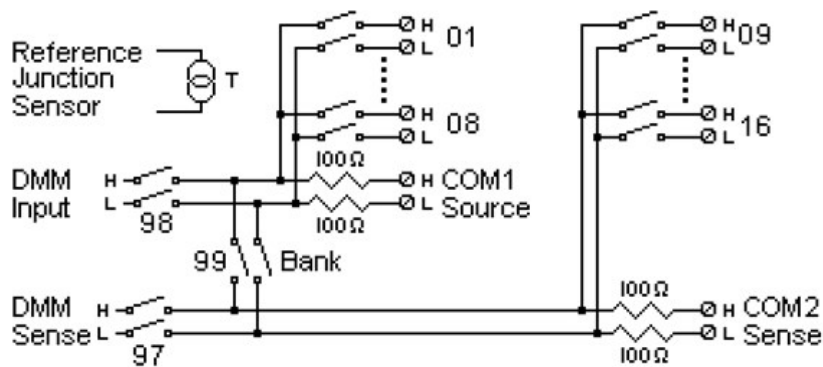

NOTE

Current measurements on this module will require external shunt resistors.

WARNING

TO PREVENT ELECTRICAL SHOCK

To prevent electrical shock, use only wire that is rated for the highest voltage to any channel. Before removing a module cover, turn off all power to external devices connected to the module.

CAUTION WITH MULTIPLE SIGNALS

To avoid the possibility of multiple signal sources becoming connected together, we recommend when multiplexing two or more sources they should be connected on separate modules or on separate banks of the same module.

CAUTION WITH HAZARDOUS VOLTAGES

When any channel is connected to a hazardous voltage source, all channels in the module should be treated as hazardous and all channel wiring in the module should be rated for the maximum voltage applied. Thermocouples attached to any other channel on the module should have insulation rated for the maximum voltage, or have additional insulation added rated for the maximum voltage and should be isolated from conductive parts using a thermal compound or tape rated for the maximum voltage applied. Do not mount, move, or remove any thermocouples when the device under test is connected to a supply source.

ENVIRONMENTAL HEALTH AND SAFETY

When any channel is connected to a hazardous voltage source, the instrument and the device under test should be supervised, following local EHS practices to restrict access.

DAQM903A 20-Channel Actuator/General-Purpose Switch Module

This module contains 20 independent, and SPDT (Form C) latching relays. This module can switch 300 V, 1 A (50 W maximum switch power) to your device under test or to actuate external devices. Screw terminals on the module provide access to the Normally-Open, Normally-Closed, and Common contacts for each of the 20 switches. This module does not connect to the internal DMM. Use this module for those applications that require high-integrity contacts or quality connections of non-multiplexed signals.

A breadboard area is provided near the screw terminals to implement custom circuitry, such as simple filters, snubbers, and voltage dividers. The breadboard area provides the space necessary to insert your own components but there are no circuit board traces here. You must add your own circuitry and signal routing.

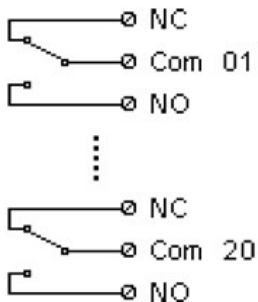

NOTE

You can close multiple channels at the same time on this module.

The channel CLOSE and OPEN commands control the state of the Normally Open (NO) to COM connection on each channel. For example, CLOSE 201 connects the Normally Open contact to COM on channel 01.

WARNING

TO PREVENT ELECTRICAL SHOCK

To prevent electrical shock, use only wire that is rated for the highest voltage to any channel. Before removing a module cover, turn off all power to external devices connected to the module.

CAUTION WITH MULTIPLE SIGNALS

To avoid the possibility of multiple signal sources becoming connected together, we recommend when multiplexing two or more sources they should be connected on separate modules or on separate banks of the same module.

CAUTION WITH HAZARDOUS VOLTAGES

When any channel is connected to a hazardous voltage source, all channels in the module should be treated as hazardous and all channel wiring in the module should be rated for the maximum voltage applied. Thermocouples attached to any other channel on the module should have insulation rated for the maximum voltage, or have additional insulation added rated for the maximum voltage and should be isolated from conductive parts using a thermal compound or tape rated for the maximum voltage applied. Do not mount, move, or remove any thermocouples when the device under test is connected to a supply source.

ENVIRONMENTAL HEALTH AND SAFETY

When any channel is connected to a hazardous voltage source, the instrument and the device under test should be supervised, following local EHS practices to restrict access.

DAQM904A 4x8 Two-Wire Matrix Switch

This module contains 32 two-wire crosspoints organized in a 4-row by 8-column configuration. You can connect rows and columns between multiple modules to build larger matrices such as 8x8 and 4x16, with up to 96 crosspoints in a single mainframe. Use this module to connect multiple instruments to multiple points, or any combination of inputs and outputs on your device under test at the same time.

This module does not connect to the internal DMM. Each crosspoint relay has its own unique channel label representing the row and column. For example, channel 32 represents the crosspoint connection between row 3 and column 2 as shown below:

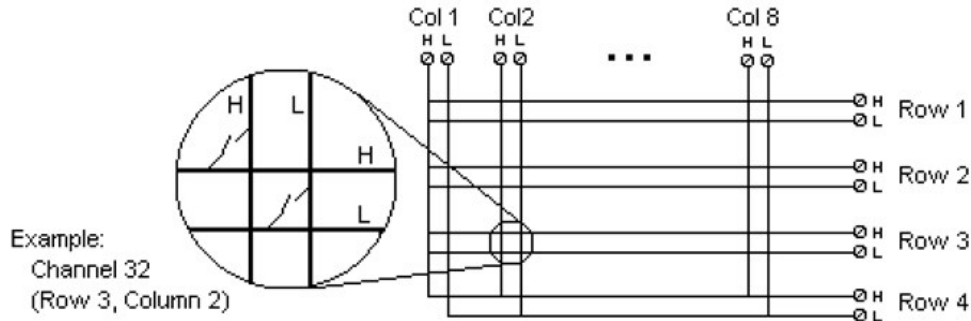

NOTE

You can close multiple channels at the same time on this module.

WARNING

TO PREVENT ELECTRICAL SHOCK

To prevent electrical shock, use only wire that is rated for the highest voltage to any channel. Before removing a module cover, turn off all power to external devices connected to the module.

CAUTION WITH MULTIPLE SIGNALS

To avoid the possibility of multiple signal sources becoming connected together, we recommend when multiplexing two or more sources they should be connected on separate modules or on separate banks of the same module.

CAUTION WITH HAZARDOUS VOLTAGES

When any channel is connected to a hazardous voltage source, all channels in the module should be treated as hazardous and all channel wiring in the module should be rated for the maximum voltage applied. Thermocouples attached to any other channel on the module should have insulation rated for the maximum voltage, or have additional insulation added rated for the maximum voltage and should be isolated from conductive parts using a thermal compound or tape rated for the maximum voltage applied. Do not mount, move, or remove any thermocouples when the device under test is connected to a supply source.

ENVIRONMENTAL HEALTH AND SAFETY

When any channel is connected to a hazardous voltage source, the instrument and the device under test should be supervised, following local EHS practices to restrict access.

DAQM905A Dual 1:4 RF Multiplexer (50 Ω) Module

These modules consist of two independent banks of 4-to-1 multiplexers, which offer wideband switching capabilities for high frequency and pulsed signals. The channels in each bank are organized in a “tree” structure to provide high isolation and low VSWR. Both modules have a common earth ground, offer low crosstalk and excellent insertion loss performance. To create larger RF multiplexers, you can cascade multiple banks together.

This module does not connect to the internal DMM. You can connect your signals directly to the on-board SMB connectors or to the SMB-to-BNC cables provided with the module.



NOTE

You can close only one channel per bank at a time on these modules; closing one channel in a bank will open the previously closed channel. One channel in each bank is always connected to COM.

This module responds only to the CLOSE command (OPEN does not apply). To OPEN a channel, send the CLOSE command to another channel in the same bank.

WARNING

TO PREVENT ELECTRICAL SHOCK

To prevent electrical shock, use only wire that is rated for the highest voltage to any channel. Before removing a module cover, turn off all power to external devices connected to the module.

CAUTION WITH MULTIPLE SIGNALS

To avoid the possibility of multiple signal sources becoming connected together, we recommend when multiplexing two or more sources they should be connected on separate modules or on separate banks of the same module.

CAUTION WITH HAZARDOUS VOLTAGES

When any channel is connected to a hazardous voltage source, all channels in the module should be treated as hazardous and all channel wiring in the module should be rated for the maximum voltage applied. Thermocouples attached to any other channel on the module should have insulation rated for the maximum voltage, or have additional insulation added rated for the maximum voltage and should be isolated from conductive parts using a thermal compound or tape rated for the maximum voltage applied. Do not mount, move, or remove any thermocouples when the device under test is connected to a supply source.

ENVIRONMENTAL HEALTH AND SAFETY

When any channel is connected to a hazardous voltage source, the instrument and the device under test should be supervised, following local EHS practices to restrict access.

DAQM907A Multifunction Module

This module combines two 8-bit ports of digital input/output, a 100 kHz totalizer, and two ± 12 V analog outputs (DAC). For greater flexibility, you can read digital inputs and the totalizer count during a scan. Use this module to sense status and control external devices such as solenoids, power relays, and microwave switches.

Digital Input/Output (DIO)

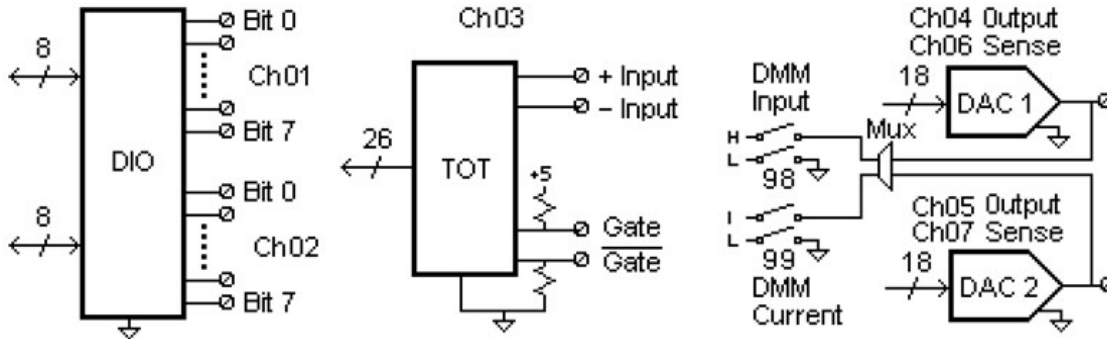

The DIO consists of two 8-bit ports with TTL-compatible inputs and output. The open-drain outputs can sink up to 400 mA. From the front panel, you can read data from only one 8-bit input port at a time. From the remote interface, you can read both ports simultaneously as a 16-bit word only if neither port is in the scan list.

Totalizer input

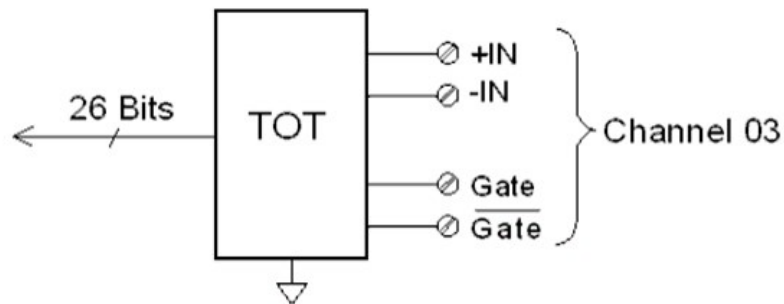

The 26-bit totalizer can count pulses at a 100 kHz rate. You can configure the totalizer to count on the rising edge or falling edge of the input signal. A TTL high signal applied to the "+" terminal enables counting and a low signal disables counting. A TTL-compatible low signal applied to the "-" terminal enables counting and a high signal disables counting. The totalizer only counts when both terminals are enabled. Move the Totalize Threshold jumper to the "AC" position to detect changes through 0 V. Move the jumper to the "TTL" position (factory setting) to detect changes through TTL threshold levels.

Analog Output (DAC) Output and Sense

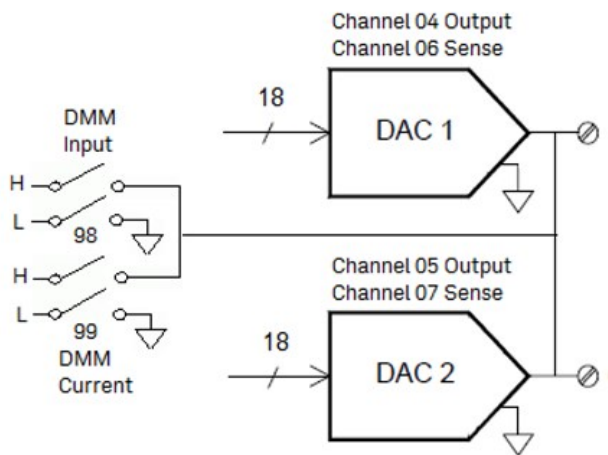

The two analog outputs (channel 04 and 05) and senses (channel 06 and 07) are capable of outputting calibrated voltages or currents with 18 bits of resolution. You must limit the DAC output current to 40 mA total for each slot (two DAC channels). Table below shows the output values of DAC in current mode and voltage mode:

Mode	Current	Voltage
Current Mode	± 24 mA	± 12 V
Voltage Mode	± 15 mA	± 12 V

WARNING

TO PREVENT ELECTRICAL SHOCK

To prevent electrical shock, use only wire that is rated for the highest voltage to any channel. Before removing a module cover, turn off all power to external devices connected to the module.

DAQM908A 40-channel Single-ended Multiplexer

The module is divided into two banks of 20 channels each. All of the 40 channels switch HI only, with a common LO for the module. Use this module for high-density switching applications which require single-wire inputs with a common LO.

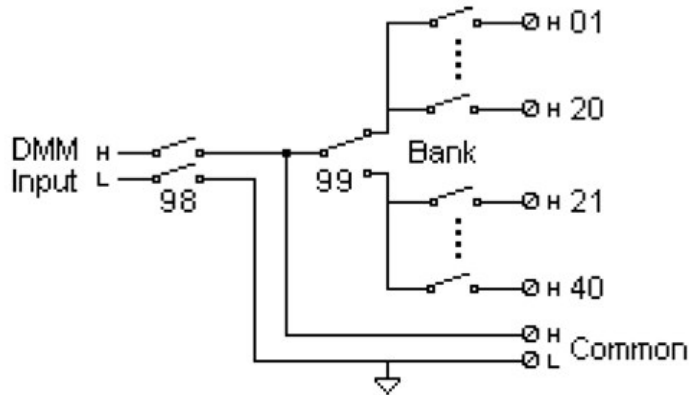

NOTE

Only one channel can be closed at a time, closing one channel will open the previously closed channel.

This module cannot be used to directly measure current or any 4-wire measurements.

WARNING

TO PREVENT ELECTRICAL SHOCK

To prevent electrical shock, use only wire that is rated for the highest voltage to any channel. Before removing a module cover, turn off all power to external devices connected to the module.

CAUTION WITH MULTIPLE SIGNALS

To avoid the possibility of multiple signal sources becoming connected together, we recommend when multiplexing two or more sources they should be connected on separate modules or on separate banks of the same module.

CAUTION WITH HAZARDOUS VOLTAGES

When any channel is connected to a hazardous voltage source, all channels in the module should be treated as hazardous and all channel wiring in the module should be rated for the maximum voltage applied. Thermocouples attached to any other channel on the module should have insulation rated for the maximum voltage, or have additional insulation added rated for the maximum voltage and should be isolated from conductive parts using a thermal compound or tape rated for the maximum voltage applied. Do not mount, move, or remove any thermocouples when the device under test is connected to a supply source.

ENVIRONMENTAL HEALTH AND SAFETY

When any channel is connected to a hazardous voltage source, the instrument and the device under test should be supervised, following local EHS practices to restrict access.

DAQM909A 4-Channel 24-Bit Digitizer Module

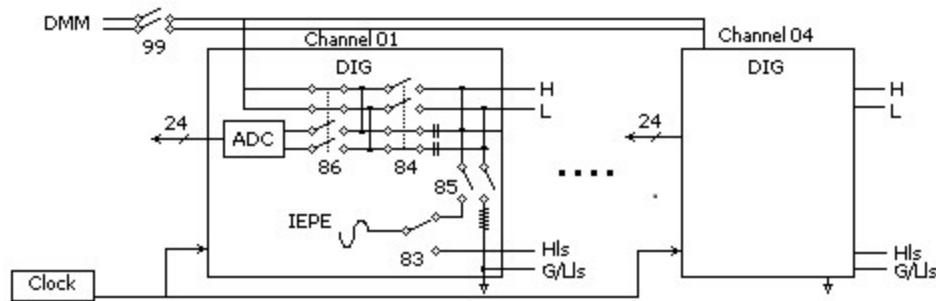

The DAQM909A is a four-channel digitizer module capable of providing four simultaneously-sampled channels with sampling rate as high as 800,000 samples per second with a maximum resolution of 24 bits. The input channels of the DAQM909A can be configured as a differential input or a single-ended input and each of the channels can provide up to 4mA of constant current to power up an external IEPE transducer. When three DAQM909A modules are inserted within the same instrument, all 12 channels can be synchronized to provide simultaneous sampling.

WARNING

DO NOT MEASURE MORE THAN THE RATED VOLTAGE

The maximum input voltage for measurement is +/-18Vpk (single ended) for both HI and LO pins.

TO PREVENT ELECTRICAL SHOCK

To prevent electrical shock, use only wire that is rated for the highest voltage to any channel. Before removing a module cover, turn off all power to external devices connected to the module.

CAUTION WITH MULTIPLE SIGNALS

To avoid the possibility of multiple signal sources becoming connected together, we recommend when multiplexing two or more sources they should be connected on separate modules or on separate banks of the same module.

CAUTION WITH HAZARDOUS VOLTAGES

When any channel is connected to a hazardous voltage source, all channels in the module should be treated as hazardous and all channel wiring in the module should be rated for the maximum voltage applied. Thermocouples attached to any other channel on the module should have insulation rated for the maximum voltage, or have additional insulation added rated for the maximum voltage and should be isolated from conductive parts using a thermal compound or tape rated for the maximum voltage applied. Do not mount, move, or remove any thermocouples when the device under test is connected to a supply source.

ENVIRONMENTAL HEALTH AND SAFETY

When any channel is connected to a hazardous voltage source, the instrument and the device under test should be supervised, following local EHS practices to restrict access.

THIS PAGE HAS BEEN INTENTIONALLY LEFT BLANK.

4 Measurement Tutorials

System Cabling and Connections

Measurement Fundamentals

Digitizing measurements

Actuators and General-Purpose Switching

Matrix Switching

RF Signal Multiplexing

Multifunction Module

Relay Life and Preventive Maintenance

This chapter describes methods that you can use to reduce errors that can affect your measurements. You will also find information to help you better understand how the DAQ970A/DAQ973A makes measurements and what you can do to get the best results.

System Cabling and Connections

This section describes methods to reduce measurement errors that can be introduced by your system cabling. Many system cabling errors can be reduced or eliminated by selecting the proper cable and grounding scheme for your system.

- **Cable specifications**
- **Grounding techniques**
- **Shielding techniques**
- **Separation of high-level and low-level signals**
- **Source of system cabling errors**

Cable specifications

A wide variety of general-purpose and custom cables are available. The following factors influence the type of cable that you choose.

- Signal requirement - such as voltage, frequency, accuracy, and measurement speed.
- Interconnection requirements - such as wire sizes, cable lengths, and cable routing.
- Maintenance requirements - such as intermediate connectors, cable terminations, strain reliefs, cable lengths, and cable routing.

Cables are specified in a variety of ways. Be sure to check the following specifications for the cable type you intend to use:

- Nominal impedance (insulation resistance) - Varies with the frequency of the input signal. Check for HI-to-LO, channel-to-channel, and HI-or LO-to-shield. High frequency RF applications have exact requirements for cable impedance.
- Dielectric withstand voltage - Must be high enough for your application.

WARNING

To prevent electrical shock or equipment damage, insulate all channels to the highest potential in the system. It is recommended that you use a wire with at least 600 V rated insulation.

- Cable resistance - Varies with wire gauge size and cable length. Use the largest gauge wire possible and try to keep the cable lengths as short as possible to minimize the cable resistance. The following table lists typical cable resistance for copper wire of several gauge sizes (the temperature coefficient for copper wire is 0.35% per °C).

AWG	Ω / ft (2 conductors) at 25 °C
14	5 m Ω
16	10 m Ω
18	15 m Ω
20 ^[1]	20 m Ω
22	30 m Ω
24	50 m Ω

- Cable capacitance - Varies with insulation type, cable length, and cable shielding. Cable should be kept as short as possible to minimize cable capacitance. In some cases, low-capacitance cable can be used.

The table below lists the typical cable specifications.

Cable Type	Nominal impedance	Capacitance	Attenuation
Twisted pair	100 Ω at 1 MHz	10 to 20 pF/ft	Up to 1 dB/100 ft at 1 MHz
Shielded twisted pair	100 Ω at 1 MHz	10 to 20 pF/ft	Up to 1 dB/100 ft at 1 MHz
Coaxial	50 Ω or 75 Ω at 100 MHz	15 to 25 pF/ft	Up to 6 dB/100 ft at 100 MHz
Twisted pair ribbon	100 Ω at 1 MHz	15 to 20 pF/ft	Up to 1 dB/100 ft at 1 MHz

^[1]Recommended wire size for the screw terminals on the DAQ970A/DAQ973A plug-in modules.

Grounding techniques

The purpose of grounding is to avoid ground loops and minimize noise. Most systems should have at least three separate ground returns.

1. One ground for signals. You may also want to provide separate signal grounds between high-level signals, low-level signals, and digital signals.
2. A second ground is used for noisy hardware such as relays, motors, and high-power equipment.
3. A third ground is used for chassis, racks, and cabinets. The AC power ground should generally be connected to this third ground.

In general, for frequencies below 1 MHz or for low-level signals, use single-point grounding (see image below). Parallel grounding is superior but it is also more expensive and more difficult to wire. If single point grounding is adequate, the most critical points (those with the lowest levels and/ or the most precise measurement requirements) should be positioned near the primary ground point. For frequencies above 10 MHz, use the separate grounding system. For signals between 1 MHz and 10 MHz, you can use a single-point system if the longest ground return path is kept to less than $1/20$ of a wavelength. In all cases, return-path resistance and inductance should be minimized.

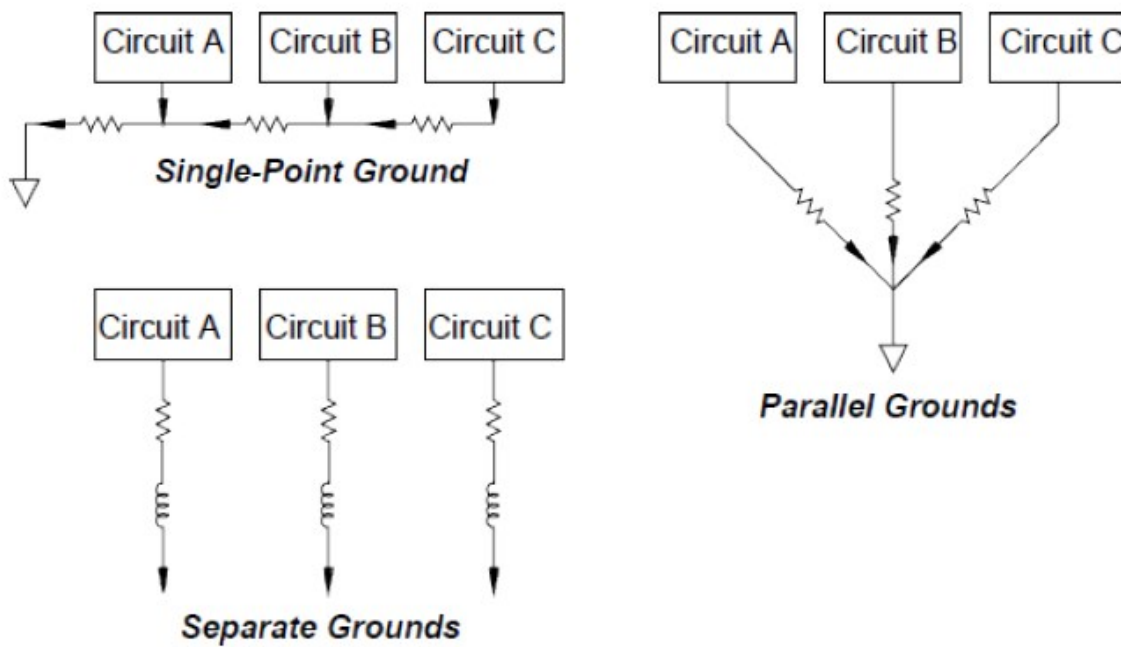

Shielding techniques

Shielding against noise must address both capacitive (electrical) and inductive (magnetic) coupling. The addition of a grounded shield around the conductor is highly effective against capacitive coupling. In switching networks, this shielding often takes the form of coaxial cables and connectors. For frequencies above 100 MHz, double-shielded coaxial cable is recommended to maximum shielding effectiveness.

Reducing loop area is the most effective method to shield against magnetic coupling. Below a few hundred kilohertz, twisted pairs may be used against magnetic coupling. Use shielded twisted pair for immunity from magnetic and capacitive pickup. For maximum protection below 1 MHz, make sure that the shield is not one of the signal conductors.

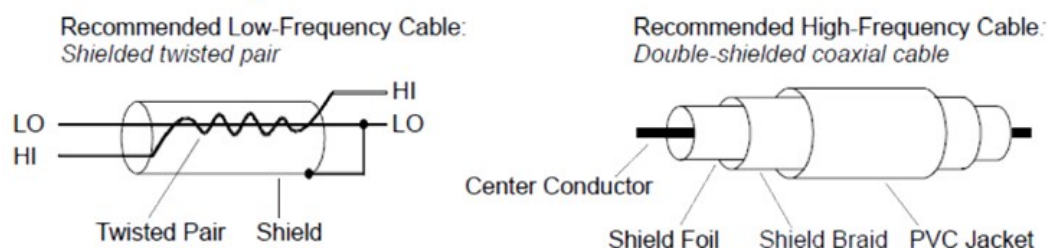

Separation of high-level and low-level signals

Signals whose levels exceed a 20-to-1 ratio should be physically separated as much as possible. The entire signal path should be examined including cabling and adjacent connections. All unused lines should be grounded (or tied to LO) and places between sensitive signal paths. When making your wiring connections to the screw terminals on the module, be sure to wire like functions on adjacent channels.

Source of system cabling errors

Radio frequency interference

Most voltage-measuring instruments can generate false readings in the presence of large, high-frequency signals. Possible sources of high-frequency signals include nearby radio and television transmitters, computer monitors, and cellular telephones. High-frequency energy can also be coupled to the internal DMM on the system cabling. To reduce the interference, try to minimize the exposure of the system cabling to high-frequency RF sources.

If your application is extremely sensitive to RF1 radiated from the instrument, use a common mode choke in the system cabling as shown below to attenuate instrument emissions.

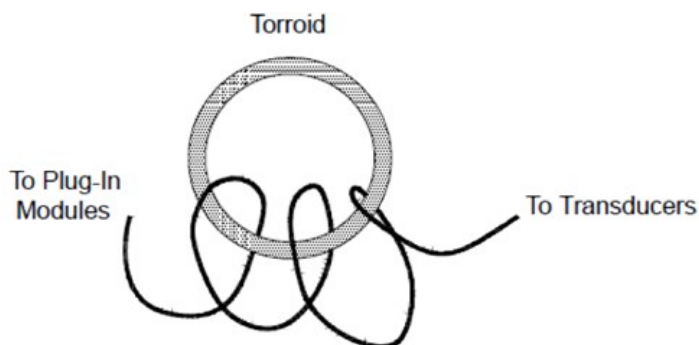

Thermal EMF errors

Thermoelectric voltages are the most common source of error in low-level DC voltage measurements. Thermoelectric voltages are generated when you make circuit connections using dissimilar metals at different temperatures. Each metal-to-metal junction forms a thermocouple, which generates a voltage proportional to the junction temperature difference. You should take the necessary precautions to minimize thermocouple voltages and temperature variations in low-level voltage measurements. The best connections are formed using copper-to-copper crimped connections. The table below shows common thermoelectric voltages for connections between dissimilar metals.

Copper-to-	Approx. $\mu\text{V}/^\circ\text{C}$
Copper	< 0.3
Gold	0.5
Silver	0.5
Brass	3
Beryllium Copper	5
Aluminium	5
Kovar or Alloy 42	40
Silicon	500
Copper-Oxide	1000
Cadmium-Tin Solder	0.2
Tin-Lead Solder	5

Noise caused by magnetic fields

If you are making measurements near magnetic fields, you should take precautions to avoid inducing voltages in the measurement connections. Voltage can be induced by either movement of the input connection wiring in a fixed magnetic field or by a varying magnetic field. An unshielded, poorly dressed input wire moving in the earth's magnetic field can generate several millivolts. The varying magnetic field around the AC power line can also induce voltages up to several hundred millivolts. You should be especially careful when working near conductors carrying large currents.

Where possible, you should route cabling away from magnetic fields. Magnetic fields are commonly present around electric motors, generators, televisions, and computer monitors. Also make sure that your input wiring has proper strain relief and is tied down securely when operating near magnetic fields. Use twisted-pair connections to the instrument to reduce the noise pickup loop area, or dress the wires as close together as possible.

Noise caused by ground loops

When measuring voltages in circuits where the internal DMM and the device-under-test are both referenced to a common earth ground, a ground loop is formed. As shown below, any voltage difference between the two ground reference points (V_{ground}) causes a current to flow through the LO measurement lead. This causes an error voltage (V_L) which is added to the measured voltage.

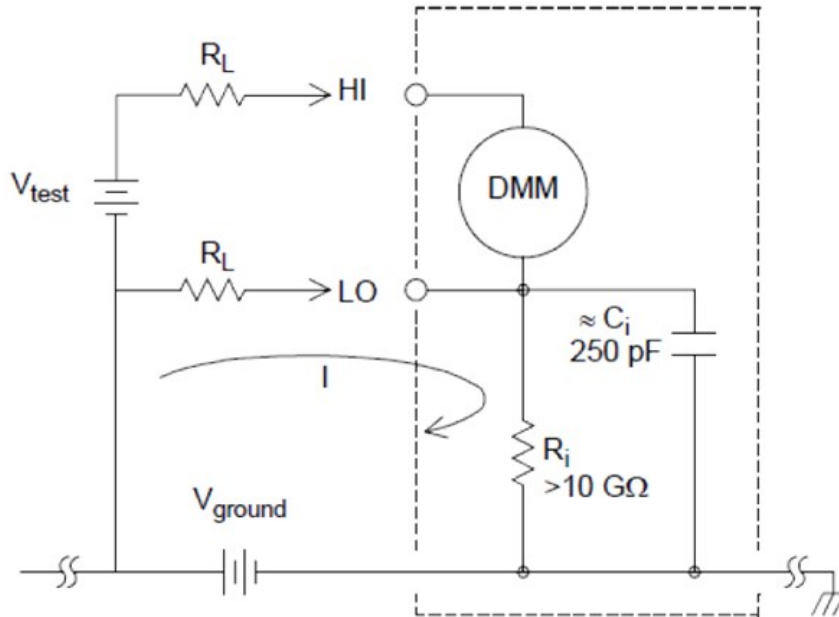

Where:

R_L = Lead resistance

R_i = DMM isolation resistance

C_i = DMM isolation capacitance

V_{ground} = Ground noise voltage

To minimize ground loop errors:

- If V_{ground} is a DC voltage, keep R_L small compared to R_i .
- If V_{ground} is an AC voltage, keep R_L small compared to Z , and set the DMM's integration time to 1 PLC or greater.

Low-level AC measurement errors

When measuring AC voltages less than 100 mV, be aware that these measurements are especially susceptible to errors introduced by extraneous noise sources. An exposed test lead will act as an antenna and the internal DMM will measure the signals received. The entire measurement path, including the power line, act as a loop antenna. Circulating currents in the loop will create error voltages across any impedances in series with the instrument's input. For this reason, you should apply low-level AC voltages to the instrument through shielded cables. You should also connect the shield to the input LO terminal.

Be sure to minimize the area of any ground loops that cannot be avoided. A high-impedance source is more susceptible to noise pickup than a low-impedance source. You can reduce the high-frequency impedance of a source by placing a capacitor in parallel with the instrument's input terminals. You may have to experiment to determine the correct capacitance value for your application.

Most extraneous noise is not correlated with the input signal. You can determine the error as shown below:

Correlated noise, while rare, is especially detrimental. Correlated noise will always add directly to the input signal. Measuring a low-level signal with the same frequency as the local power line is a common situation that is prone to this error.

You should use caution when switching high-level and low-level signals on the same module. It is possible that high-level charged voltages may be discharged onto a low-level channel. It is recommended that you either use two different modules or separate the high-level signals from the low-level signals with an unused channel connected to ground.

Measurement Fundamentals

This section explains how the DAQ970A/DAQ973A makes measurements and discusses the most common sources of error related to these measurements.

- The internal DMM
- Temperature measurements
- DC voltage measurements
- AC voltage measurements
- Current measurements
- Resistance measurement
- Strain gage measurements
- Frequency and period measurements
- Capacitance measurements
- Digitizing measurements
- Level triggering

The internal DMM

The internal DMM provides a universal input front-end for measuring a variety of transducer types without the need for additional external signal conditioning. The internal DMM includes signal conditioning, amplification (or attenuation), and a high resolution (up to 22 bits) analog-to-digital converter. A simplified diagram of the internal DMM is shown below.

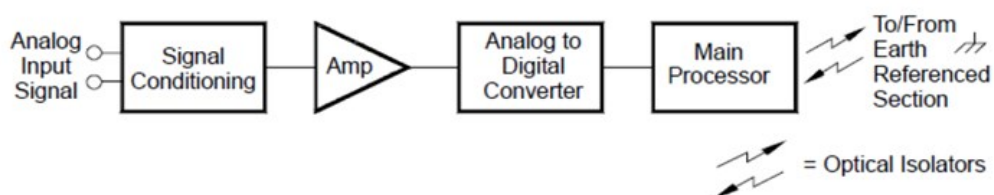

The internal DMM can directly make the following types of measurements. Each of these measurements is described in the following sections of this chapter:

- Temperature (thermocouple, 2-wire and 4-wire RTD, 2-wire and 4-wire thermistor)
- Voltage (DC and AC up to 300 V)
- Resistance (2-wire and 4-wire up to 1 G Ω)
- Current (DC and AC up to 1 A)
- Frequency and Period (up to 300 kHz)
- Strain (bridge and direct methods)

Rejecting Power-Line Noise Voltages

A desirable characteristic of an integrating analog-to-digital (A/D) converter is its ability to reject spurious signals. Integrating techniques reject power-line related noise present with DC signals on the input. This is called normal mode rejection or NMR. Normal mode noise rejection is achieved when the internal DMM measures the average of the input by “integrating” it over a fixed period. If you set the integration time to a whole number of power line cycles (PLCs) of the spurious input, these errors (and their harmonics) will average out to approximately zero.

When you apply power to the internal DMM, it measures the power-line frequency (50 Hz or 60 Hz), and uses this measurement to determine the integration time. The following graph shows the attenuation of AC signals measured in the DC voltage function for various A/D integration time settings. Note that signal frequencies at multiples of $1/T$ exhibit high attenuation.

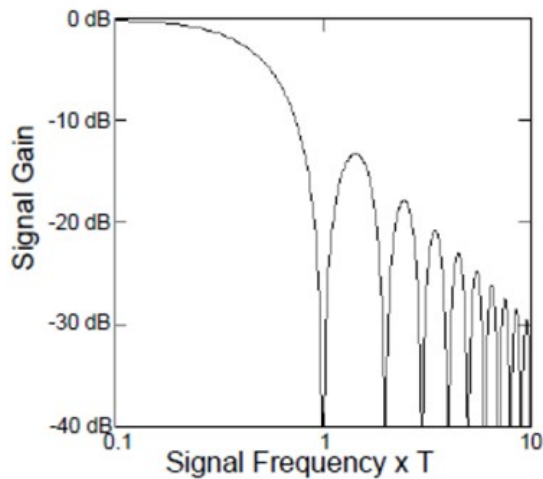

Temperature measurements

A temperature transducer measurement is typically either a resistance or voltage measurement converted to an equivalent temperature by software conversion routines inside the instrument. The mathematical conversion is based on specific properties of the various transducers. The mathematical conversion accuracy (not including the transducer accuracy) for each transducer type is shown below:

Transducer	Conversion Accuracy
Thermocouple	0.05 °C
RTD	0.02 °C
Thermistor	0.05 °C

Errors associated with temperature measurements include all of those listed for DC voltage and resistance measurements elsewhere in this chapter. The largest source of error in temperature measurements is generally the transducer itself.

Your measurement requirements will help you to determine which temperature transducer type to use. Each transducer type has a particular temperature range, accuracy, and cost. The table below summarizes some typical specifications for each transducer type. Use this information to help select the transducer for your application. The transducer manufacturers can provide you with exact specifications for a particular transducer.

Parameter	Thermocouple	RTD	Thermistor
Temperature Range	-210 °C to 1820 °C	-200 °C to 850 °C	-80 °C to 150 °C
Measurement Type	Voltage	2- or 4- Wire Ohms	2- or 4- Wire Ohms
Transducer Sensitivity	6 $\mu\text{V}/^\circ\text{C}$ to 60 $\mu\text{V}/^\circ\text{C}$	$\approx R_0 \times 0.004 \text{ }^\circ\text{C}$	$\approx 400 \text{ } \Omega/^\circ\text{C}$
Probe Accuracy	0.5 °C to 5 °C	0.01 °C to 0.1 °C	0.1 °C to 1 °C
Cost (U.S. Dollars)	\$1/foot	\$20 to \$100 each	\$10 to \$100 each
Durability	Rugged	Fragile	Fragile

RTD measurements

An RTD is constructed of a metal (typically platinum) that changes resistance with a change in temperature in a precisely known way. The internal DMM measures the resistance of the RTD and then calculates the equivalent temperature.

An RTD has the highest stability of the temperature transducers. The output from an RTD is also very linear. This makes an RTD a good choice for high-accuracy and long-term measurements. The DAQ970A/DAQ973A supports RTDs with $\alpha = 0.00385$ (DIN / IEC 751) using ITS-90 software conversions. “PT100” is a special label that is sometimes used to refer to an RTD with $\alpha = 0.00385$ and $R_0 = 100 \text{ } \Omega$.

The resistance of an RTD is nominal at 0 °C and is referred to as R_0 . The DAQ970A/DAQ973A can measure RTDs with R_0 values from $100 \text{ } \Omega \pm 1\%$ or $1000 \text{ } \Omega \pm 1\%$.

You can measure RTDs using a 2-wire or 4-wire measurement method. The 4-wire method provides the most accurate way to measure small resistances. Connection lead resistance is automatically removed using the 4-wire method.

Thermistor measurements

A thermistor is constructed of materials that non-linearly changes resistance with changes in temperature. The internal DMM measures the resistance of the thermistor and then calculates the equivalent temperature.

Thermistors have a higher sensitivity than thermocouples or RTDs. This makes a thermistor a good choice when measuring very small changes in temperature. Thermistors are, however, very non-linear, especially at high temperatures and function best below 100 °C.

Because of their high resistance, thermistors can be measured using a 2-wire measurement method. The internal DMM supports 2.2 k Ω (44004), 5 k Ω (44007), and 10 k Ω (44006) thermistors. The thermistor conversion routines used by the DAQ970A/DAQ973A are compatible with the International Temperature Scale of 1990 (ITS-90).

Thermocouple Measurements

A thermocouple converts temperature to voltage. When two wires composed of dissimilar metals are joined, a voltage is generated. The voltage is a function of the junction temperature and the types of metals in the thermocouple wire. Since the temperature characteristics of many dissimilar metals are well known, a conversion from the voltage generated to the temperature of the junction can be made. For example, a voltage measurement of a T-type thermocouple (made of copper and constantan wire) might look like this.

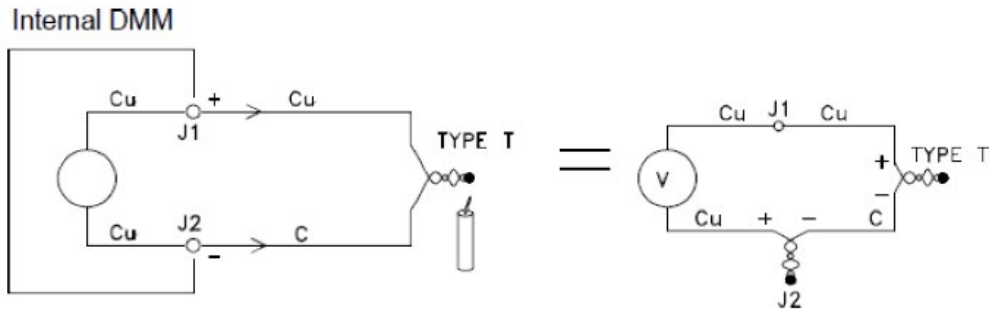

Notice, however, that the connections made between the thermocouple wire and the internal DMM make a second, unwanted thermocouple where the constantan (C) lead connects to the internal DMM's copper (Cu) input terminal. The voltage generated by this second thermocouple affects the voltage measurement of the T-type thermocouple.

If the temperature of the thermocouple created at J2 (the LO input terminal) is known, the temperature of the T-type thermocouple can be calculated. One way to do this is to connect two T-type thermocouples together to create only copper-to-copper connections at the internal DMM's input terminals, and to hold the second thermocouple at a known temperature.

An *ice bath* is used to create a known reference temperature (0 °C). Once the reference temperature and thermocouple type are known, the temperature of the measurement thermocouple can be calculated.

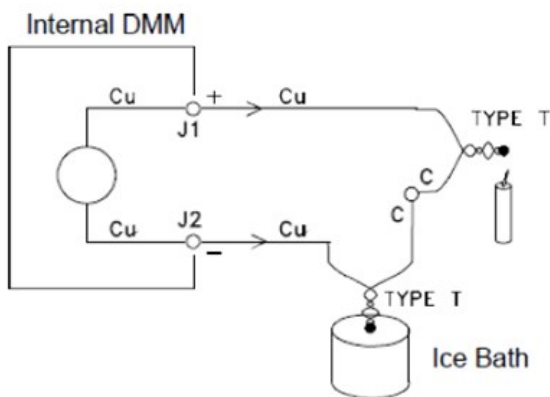

The T-type thermocouple is a unique case since one of the conductors (copper) is the same metal as the internal DMM's input terminals. If another type of thermocouple is used, two additional thermocouples are created. For example, take a look at the connections with a J-type thermocouple (iron and constantan):

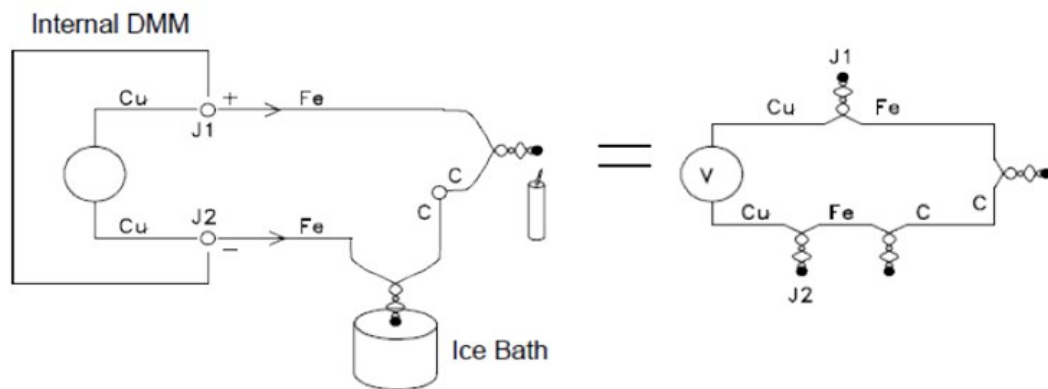

Two additional thermocouples have been created where the iron (Fe) lead connects to the internal DMM's copper (Cu) input terminals. Since these two junctions will generate opposing voltages, their effect will be to cancel each other. However, if the input terminals are not at the same temperature, an error will be created in the measurement.

To make a more accurate measurement, you should extend the copper test leads of the internal DMM closer to the measurement and hold the connections to the thermocouple at the same temperature.

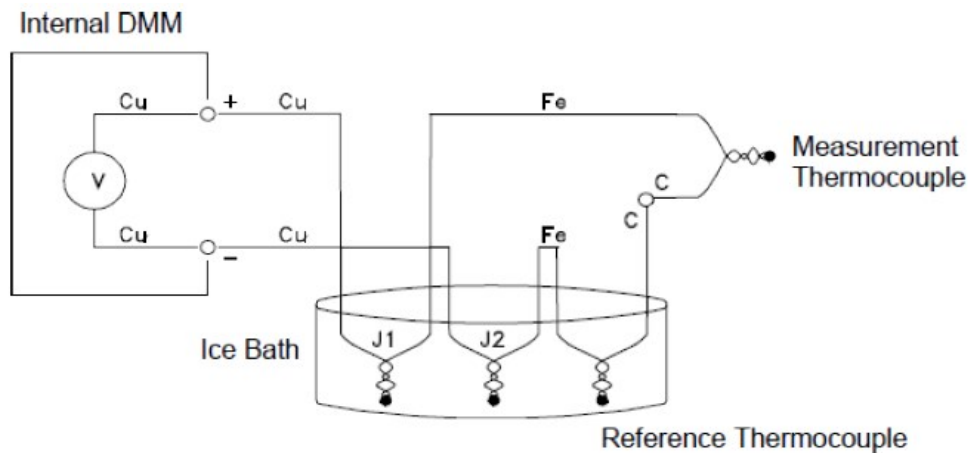

This circuit will give accurate temperature measurements. However, it is not very convenient to make two thermocouple connections and keep all connections at a known temperature. The Law of Intermediate Metals eliminates the need for the extra connection. This empirical law states that a third metal (iron (Fe) in this example) inserted between two dissimilar metals will have no effect upon the output voltage, provided the junctions formed are at the same temperature. Removing the reference thermocouple makes the connections much easier.

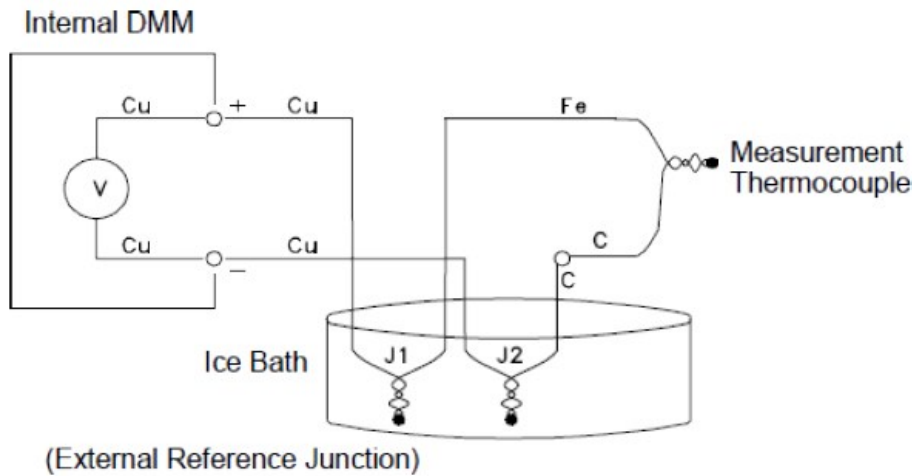

This circuit is the best solution for accurate thermocouple connections.

In some measurement situations, however, it would be nice to remove the need for an ice bath (or any other fixed external reference). To do this, an isothermal block is used to make the connections. An isothermal block is an electrical insulator, but a good heat conductor. The additional thermocouples created at J1 and J2 are now held at the same temperature by the isothermal block.

Once the temperature of the isothermal block is known, accurate temperature measurements can be made. A temperature sensor is mounted to the isothermal block to measure its temperature.

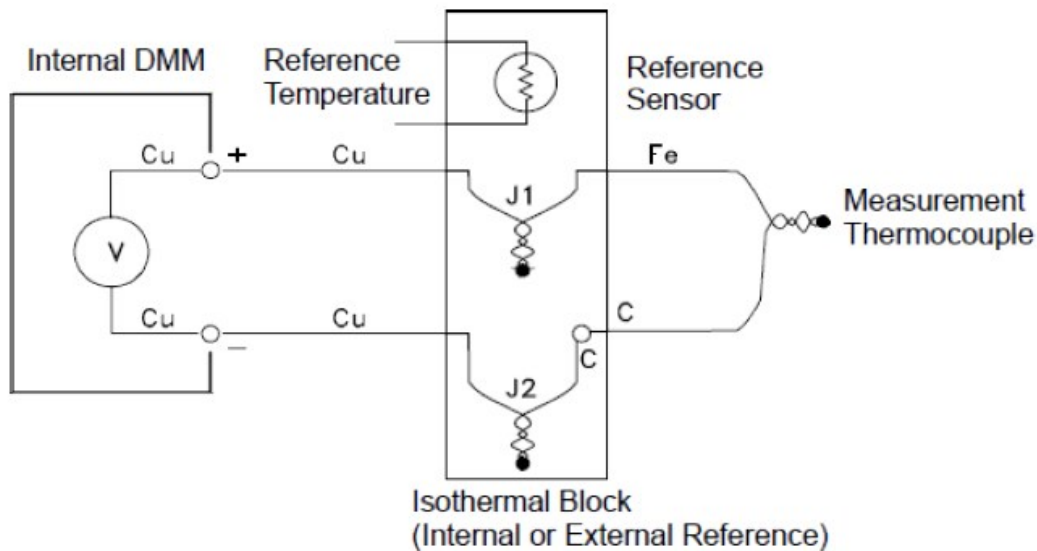

Thermocouples are available in a variety of types. The type is specified by a single letter. The table below shows the most commonly used thermocouple types and some key characteristics of each.

NOTE

The thermocouple conversion routines used by the DAQ970A/DAQ973A are compatible with the International Temperature Scale of 1990 (ITS-90).

Thermocouple types:

T/C Type	Post (+) Lead	Neg (-) Lead	Temperature Range	Probe Accuracy	Comments
B	Platinum-30% Rhodium	Platinum-60% Rhodium	250 °C - 1820 °C	±0.5 °C	High temperature.
U.S.	Gray	Red			Beware of
British	N/A	N/A			contamination.
DIN	Red	Gray			Do not insert in metal
Japanese	Red	Gray			tubes.
French	N/A	N/A			
E	Nickel-Chromium	Constantan	-200 °C - 1000 °C	±1 °C - 1.7 °C	Highest output
U.S.	Purple	Red			voltage.
British	Brown	Blue			Highest resolution.
DIN	Red	Black			
Japanese	Red	White			
French	Yellow	Blue			
J	Iron	Constantan	-210 °C - 1200 °C	±1.1 °C - 2.2 °C	For vacuum, inert
U.S.	White	Red			environments.
British	Yellow	Blue			Least expensive.
DIN	Red	Blue			Not recommended for
Japanese	Red	White			low temperature.
French	Yellow	Black			
K	Nickel-Chromium	Nickel-Aluminium	-200 °C - 1370 °C	±1.1 °C - 2.2 °C	For oxidizing
U.S.	Yellow	Red			environments.
British	Brown	Blue			Good linearity above
DIN	Red	Green			8 °C.
Japanese	Red	White			
French	Yellow	Purple			
N	Nicrosil	Nisil	-200 °C - 1300 °C	±1.1 °C - 2.2 °C	Superior stability to K
U.S.	Orange	Red			type at higher tem-
British	N/A	N/A			peratures.
DIN	N/A	N/A			
Japanese	N/A	N/A			
French	N/A	N/A			
R	Platinum -13% Rhodium	Rhodium	-50 °C - 1760 °C	±0.6 °C - 1.5 °C	Higher temperature.
U.S.	Black	Red			Beware of
British	White	Blue			contamination.
DIN	Red	White			Do not insert in metal
Japanese	Red	White			tubes.
French	Yellow	Green			
S	Platinum -10% Rhodium	Platinum	-50 °C - 1760 °C	±0.6 °C - 1.5 °C	Low error, good
U.S.	Black	Red			stability.
British	White	Blue			High temperature.
DIN	Red	White			Beware of
Japanese	Red	White			contamination.
French	Yellow	Green			Do not insert in metal
					tubes

T/C Type	Post (+) Lead	Neg (-) Lead	Temperature Range	Probe Accuracy	Comments
T	Copper	Constantan	-200 °C - 400 °C	±0.5 °C - 1 °C	Withstands moisture.
U.S.	Blue	Red			Has a copper lead.
British	White	Blue			Low temperature applications.
DIN	Red	Brown			
Japanese	Red	White			
French	Yellow	Blue			

NOTE

Constantan = Copper-Nickel; Nicrosil = Nickel-Chromium-Silicon; Nisil = Nickel-Silicone-Magnesium; N/A = Not Available

Sources of error in thermocouple measurements

Reference junction error

A thermocouple is typically formed by welding or soldering two wires together to make the junction. Soldering introduces a third metal into the junction. Provided that both sides of the thermocouple are at the same temperature, the third metal has little effect.

Commercial thermocouples are welded using a capacitive-discharge technique. This technique is used to prevent overheating of the thermocouple wire near the junction and to prevent the diffusion of the welding gas and atmosphere into the thermocouple wire.

A poor weld or bad solder connection can also cause errors in a thermocouple measurement. Open thermocouple junctions can be detected by checking the resistance of the thermocouple. A resistance measurement of more than 5 k Ω typically indicates a defective thermocouple. The DAQ970A/DAQ973A contains a built-in, automatic thermocouple check feature. If you enable this feature, the instrument measures the channel resistance after each thermocouple measurement to ensure a proper connection.

Diffusion error

Diffusion in a thermocouple wire is the process of changing the alloy type along the wire itself. Atmospheric particles can actually diffuse into the metal. These changes in the wire alloy introduce small voltage changes in the measurement. Diffusion is caused by exposure to high temperatures along the wire or by physical stress to the wire such as stretching or vibration.

Temperature errors due to diffusion are hard to detect since the thermocouple will still respond to temperature changes and give nearly correct results. The diffusion effects are usually detected as a drift in the temperature measurements.

Replacing a thermocouple which exhibits a diffusion error may not correct the problem. The extension wire and connections are all subject to diffusion. Examine the entire measurement path for signs of temperature extremes or physical stress. If possible, keep the temperature gradient across the extension wire to a minimum.

Shunt Impedance

The insulation used for thermocouple wire and extension wire can be degraded by high temperatures or corrosive atmospheres. These breakdowns appear as a resistance in parallel with the thermocouple junction. This is especially apparent in systems using a small gauge wire where the series resistance of the wire is high.

Shielding

Shielding reduces the effect of common mode noise on a thermocouple measurement. Common mode noise is generated by sources such as power lines and electrical motors. The noise is coupled to the unshielded thermocouple wires through distributed capacitance. As the induced current flows to ground through the internal DMM, voltage errors are generated along the distributed resistance of the thermocouple wire. Adding a shield to the thermocouple wire will shunt the common mode noise to earth ground and preserve the measurement.

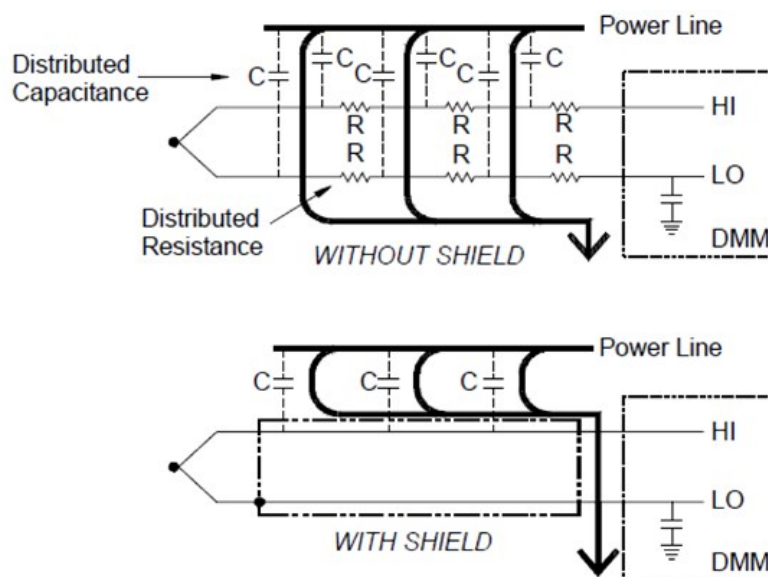

Common mode noise can dramatically affect the internal DMM. A typical thermocouple output is a few millivolts and a few millivolts of common mode noise can overload the input to the internal DMM.

Calculation Error

An error is inherent in the way a thermocouple voltage is converted to a temperature. These calculation errors are typically very small compared to the errors of the thermocouple, wiring connections, and reference junction.

DC voltage measurements

To make a useful DC meter, a “front-end” is required to condition the input before the analog-to-digital conversion. Signal conditioning increases the input resistance, amplifies small signals, and attenuates large signals to produce a selection of measuring ranges.

Signal Conditioning for DC Measurements

Input signal conditioning for DC voltage measurements includes both amplification and attenuation. A simplified input to the internal DMM is shown below:

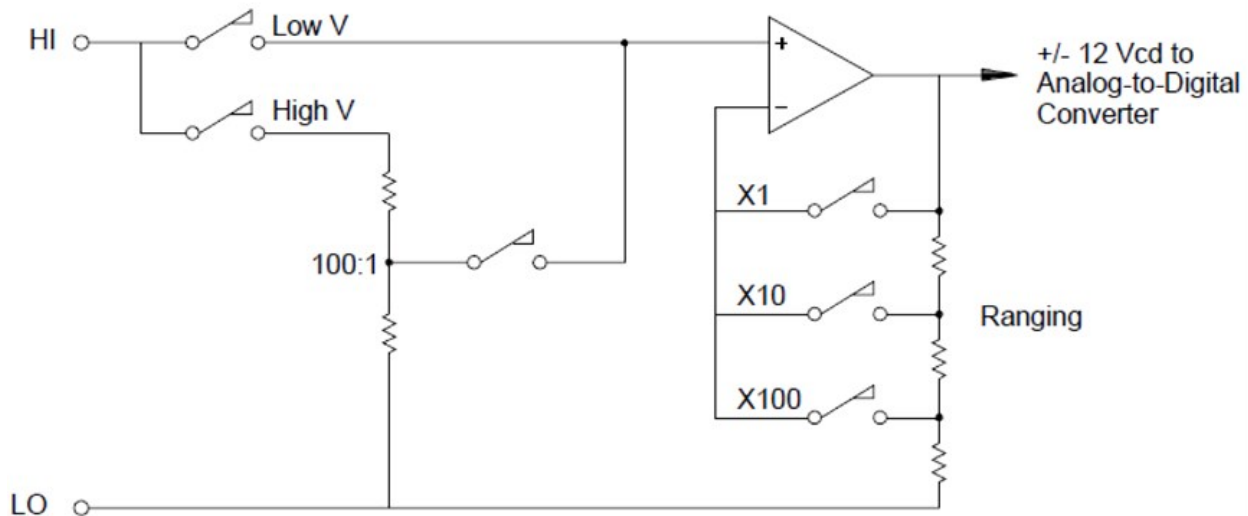

For input voltages less than 12 VDC, the Low V switch is closed and applies the input signal directly to the input amplifier. For higher voltages, the High V switch is closed and the signal is attenuated 100:1 before being applied to the input amplifier. The input amplifier gain is set to one of three values (x1, x10, or x100) to yield a signal in the range of ± 12 VDC for the analog-to-digital converter.

For the lower voltage ranges, the internal DMM’s input resistance is essentially that of the input amplifier. The input amplifier uses a low bias current (less than 50 pA) FET input stage yielding an input resistance greater than $10\text{ G}\Omega$. On the 100V and 300V input ranges, the input resistance is determined by the total resistance of the 100:1 divider. You can also set the input resistance to $10\text{ M}\Omega$ by continuously closing the High V switch.

Sources of error in DC voltage measurements

Common Mode rejection

Ideally, the internal DMM is completely isolated from earth-referenced circuits. However, there is finite resistance and capacitance between the input LO terminal and earth ground. If the input terminals are both driven by an earth-referenced signal (V_f) then a current will flow through R_S and create a voltage drop V_L as shown below:

Any resulting voltage (V_L) will appear as an input to the internal DMM. As the value of R_S approaches zero, so does the error. Additionally, if V_f is at the power line frequency (50 Hz or 60 Hz), the noise can be greatly reduced by setting the internal DMM's integration time to 1 PLC or greater.

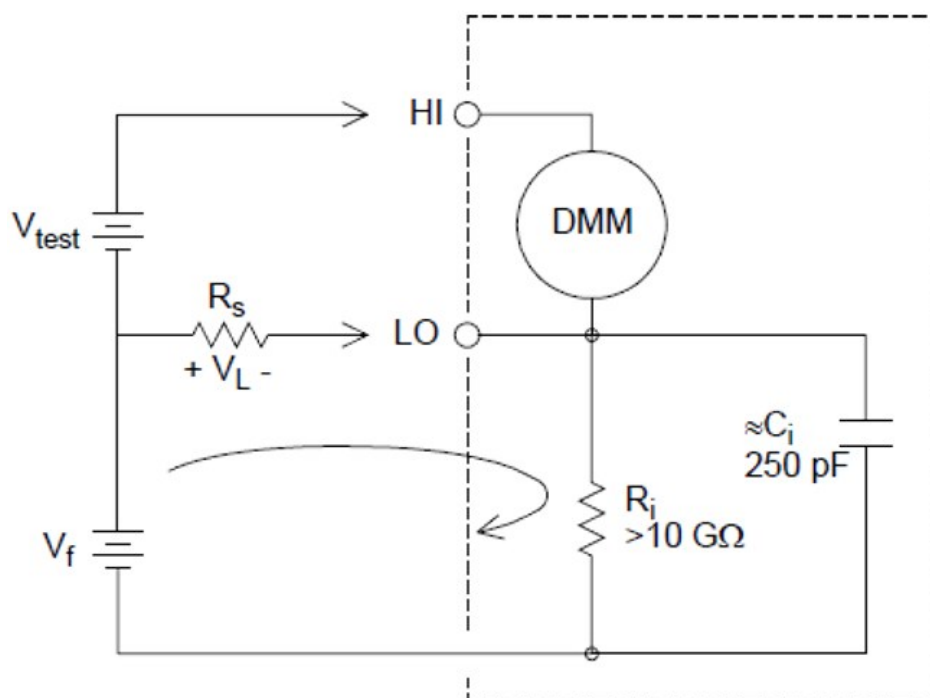

Where:

V_f = Common mode float voltage

R_s = LO lead resistance

R_i = Isolation resistance

C_i = Isolation capacitance

Z_i = Parallel impedance of $R_i + C_i$

Noise caused by injected current

Residual capacitance in the instrument's power transformer cause small currents to flow from the LO terminal of the internal DMM to earth ground. The frequency of the "injected current" is the power line frequency or possibly harmonics of the power line frequency. The injected current is dependent upon the power line configuration and frequency. A simplified circuit is shown below:

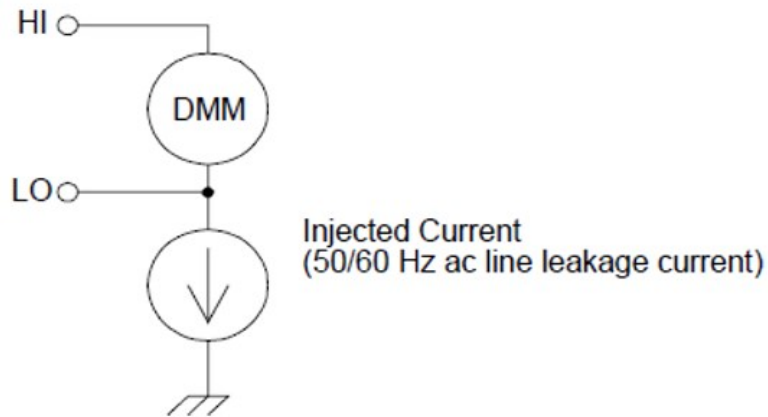

With Connection A (see below), the injected current flows from the earth connection provided by the circuit to the LO terminal of the internal DMM. This configuration adds no noise to the measurement. However, with Connection B, the injected current flows through the resistor R thus adding noise to the measurement. With Connection B, larger values of R will make the problem worse.

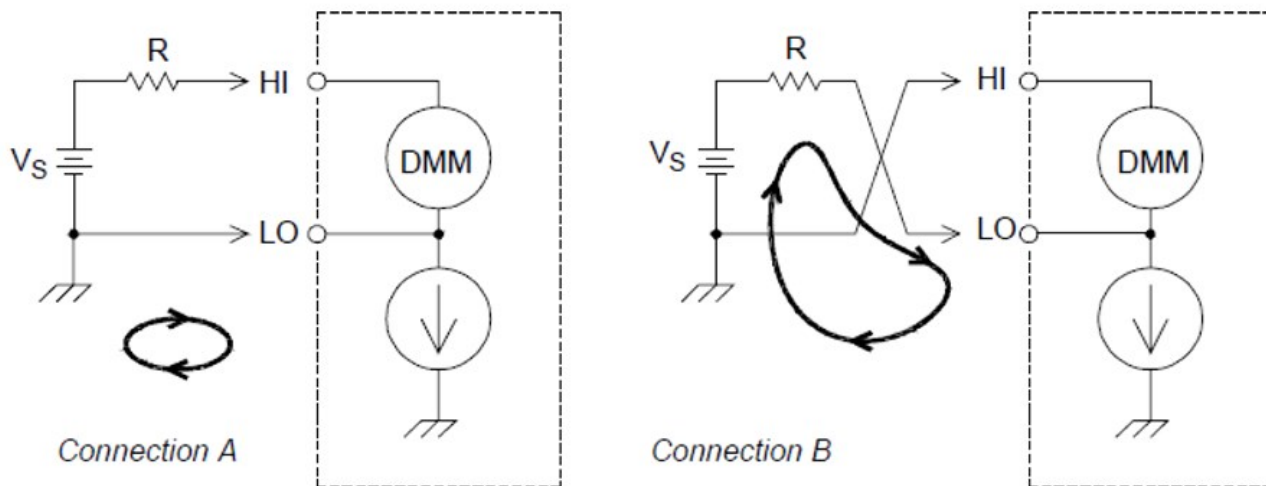

The measurement noise caused by injected current can be significantly reduced by setting the integration time of the internal DMM to 1 PLC or greater.

Loading Errors Due to Input Resistance

Measurement loading errors occur when the resistance of the device-under-test (DUT) is an appreciable percentage of the instrument's own input resistance. The diagram below shows this error source:

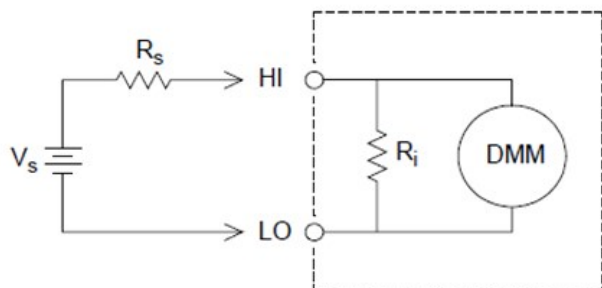

Where:

V_s = Ideal DUT voltage

R_s = DUT source resistance

R_i = Input resistance (10 M Ω or >10 G Ω)

To minimize loading errors, set the DMM's DC input resistance to greater than 10 G Ω when needed.

Loading Errors Due to Input Bias Current

The semiconductor devices used in the input circuits of the internal DMM have slight leakage currents called bias currents. The effect of the input bias current is a loading error at the internal DMM's input terminals. The leakage current will approximately double for every 10 °C temperature rise, thus making the problem much more apparent at higher temperatures.

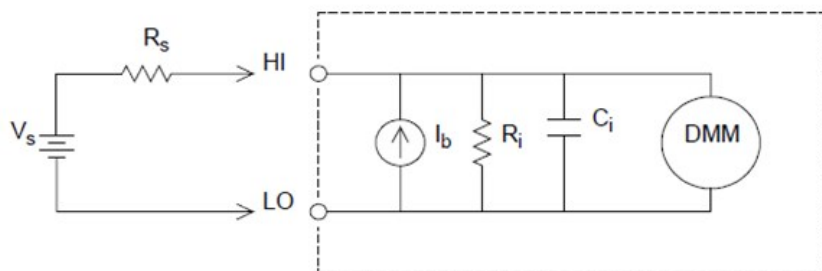

Where:

I_b = DMM bias current

R_s = DUT source resistance

R_i = Input resistance (10 M Ω or >10 G Ω)

C_i = DMM input capacitance

AC voltage measurements

The main purpose of an AC “front end” is to change an AC voltage input into a DC voltage which can be measured by the ADC.

Signal conditioning for AC measurements

Input signal conditioning for AC voltage measurements includes both attenuation and amplification. An input coupling capacitor (C) blocks the DC portion of the input signal so that only the AC component is measured. Ranging is accomplished by combining signal attenuation from the first-stage amplifier and gain from the second-stage amplifier.

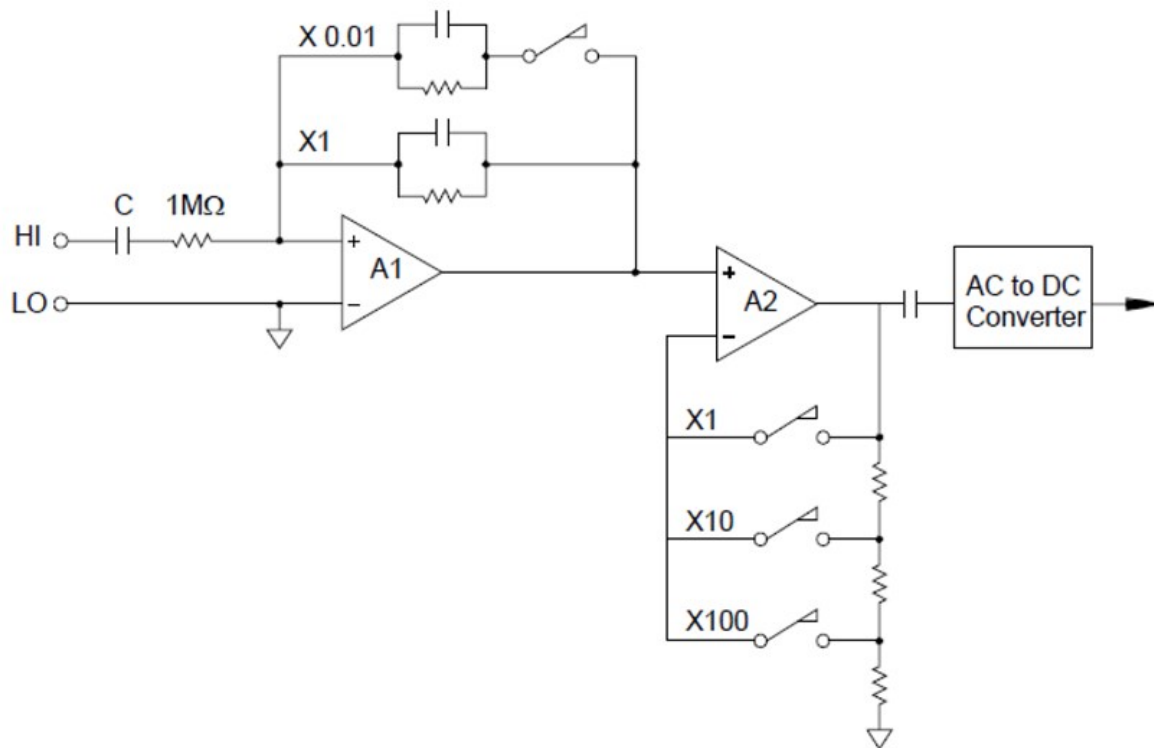



The first stage implements a high input impedance ($1\text{ M}\Omega$) switchable compensated attenuator. The second stage provides variable-gain signal amplification to scale the input to the AC converter to the fullscale level. Any residual DC offset from the attenuator and amplifier stages is blocked by a capacitor.

An AC voltage front end similar to the one discussed above is also used to measure AC current. Shunt resistors convert the AC current into an AC voltage which can then be measured. Current shunts are switched to provide selectable AC current ranges.

True RMS AC measurements

True RMS responding multimeters measure the “heating” potential of an applied voltage. Unlike an “average responding” measurement, a true RMS measurement is used to determine the power dissipated in a resistor. The power is proportional to the square of the measured true RMS voltage, independent of waveshape. An average responding AC multimeter is calibrated to read the same as a true RMS meter for sinewave inputs only. For other waveform shapes, an average responding meter will exhibit substantial errors as shown below:

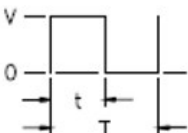
Waveform Shape	Crest Factor (C.F.)	AC RMS	AC+DC RMS	Average Responding Error
	1.414	$\frac{V}{1.414}$	$\frac{V}{1.414}$	Calibrated for 0 error
	1.732	$\frac{V}{1.732}$	$\frac{V}{1.732}$	-3.9%
	$\sqrt{\frac{T}{t}}$	$\frac{V}{C.F.} \times \sqrt{1 - \left(\frac{1}{C.F.}\right)^2}$	$\frac{V}{C.F.}$	-46% for C.F. = 4

The internal DMM’s AC voltage and AC current functions measure the ac-coupled true RMS value. This is in contrast to the ac+dc true RMS value shown above. Only the “heating value” of the AC component of the input waveform is measured (dc is rejected). For sinewaves, triangle waves, and square waves, the AC and AC+DC values are equal since these waveforms do not contain a DC offset. Non-symmetrical waveforms, such as pulse trains, contain DC voltages which are rejected by ac-coupled true RMS measurements.

An ac-coupled true RMS measurement is desirable in situations where you are measuring small AC signals in the presence of large DC offsets. For example, this situation is common when measuring AC ripple present on DC power supplies. There are situations, however, where you might want to know the ac+dc true RMS value. You can determine this value by combining results from DC and AC measurements as shown below. You should perform the DC measurement using at least 10 power line cycles of integration for best AC rejection.

Making high-speed AC measurements

The internal DMM's AC voltage and AC current functions implement three low-frequency filters. These filters allow you to trade-off low frequency accuracy for faster scanning speed. The fast filter settles in 0.12 seconds and is useful for measurements above 200 Hz. The medium filter settles in 1 second and is useful for measurements above 20 Hz. The slow filter settles in 7 seconds and is useful for measurements above 3 Hz.

With a few precautions, you can perform AC measurements at speeds up to 100 readings per second (use manual ranging to eliminate autoranging delays). By setting the preprogrammed channel settling delays to zero, each filter will allow up to 100 channels per second. However, the measurement might not be very accurate since the filter is not fully settled. In scanning applications where sample-to-sample levels vary widely, the medium filter (20 Hz) will settle at 1 reading per second, and the fast filter (200 Hz) will settle at 10 readings per second.

If the sample-to-sample levels are similar, little settling time is required for each new reading. Under this specialized condition, the medium filter (20 Hz) will provide reduced accuracy results at 5 readings per second, and the fast filter (200 Hz) will provide reduced accuracy results at 50 readings per second. Additional settling time may be required when the DC level varies from sample to sample.

The internal DMM's DC blocking circuitry has a settling time constant of 0.2 seconds. This settling time only affects measurement accuracy when DC offset levels vary from sample to sample. If maximum measurement speed is desired in a scanning system, you may want to add an external DC blocking circuit to those channels with significant DC voltages present. This circuit can be as simple as a resistor and a capacitor.

AC filter	Channel delay	Setting time
200 Hz (Fast)	AUTO	0.12 seconds
20 Hz (Medium)	AUTO	1 second
3 Hz (Slow)	AUTO	7 seconds
200 Hz (Fast)	0	0.02 seconds
20 Hz (Medium)	0	0.2 seconds
3 Hz (Slow)	0	1.5 seconds

DC blocking settling time (1 time constant) = 0.2 seconds.

Sources of error in AC voltage measurements

Many of the errors associated with DC voltage measurements also apply to AC voltage measurements. Additional errors unique to AC voltage measurements are described in this section.

Crest Factor Errors (non-sinusoidal inputs)

A common misconception is that “since the internal DMM is true RMS, its sinewave accuracy specifications apply to all waveforms.” Actually, the shape of the input signal can dramatically affect measurement accuracy. A common way to describe signal waveshapes is crest factor. Crest factor is the ratio of the peak value to the RMS value of a waveform.

In general, the greater the crest factor the greater the energy contained in higher frequency harmonics. All multimeters exhibit measurement errors that are crest factor dependent. Note that the crest factor errors do not apply for input signals below 100 Hz when using the slow AC filter.

You can estimate the measurement error due to signal crest factor as shown below:

Where:

$\text{Error}_{\text{sinewave}} = \text{DMM's sinewave accuracy}$

$\text{Error}_{\text{crest factor}} = \text{DMM's crest factor}$

$\text{Error}_{\text{bandwidth}} =$

Where:

C.F = Signal crest factor

F = Fundamental input signal frequency

BW = DMM's -3dB bandwidth (1 MHz for the DAQ970A/DAQ973A)

Example: Calculating measurement error

Calculate the approximate measurement error for a pulse train input with a crest factor of 3 and a fundamental frequency of 20 kHz. The internal DMM is set to the 1 V range. For this example, use the 90-day accuracy specifications of $\pm (0.05\% \text{ of reading} + 0.04\% \text{ of range})$.

$\text{Error}_{\text{sinewave}} = \pm(0.05\% + 0.04\%) = \pm 0.09\%$

$\text{Error}_{\text{crest factor}} = 0.15\%$

$\text{Error}_{\text{bandwidth}} =$

$\text{Total Error} = 0.09\% + 0.15\% + 1.4\% = 1.6\%$

AC Loading Errors

In the AC voltage function, the input of the internal DMM appears as a 1 M Ω resistance in parallel with 150 pF of capacitance. The cabling that you use to connect signals to the instrument will also add additional capacitance and loading. The table below shows the approximate input resistance at various frequencies.

Input frequency	Input resistance
100 Hz	700 k Ω
1 kHz	600 k Ω
10 kHz	100 k Ω
100 kHz	10 k Ω

For low frequencies:

Additional error for high frequencies:

Where:

F = Input Frequency

R_S = Source resistance

C_{in} = Input capacitance (150 pF) + Cable capacitance

Use low-capacitance cable when measuring high frequency AC signals.

Low-level AC measurement errors

When measuring AC voltages less than 100 mV, be aware that these measurements are especially susceptible to errors introduced by extraneous noise sources. An exposed test lead will act as an antenna and the internal DMM will measure the signals received. The entire measurement path, including the power line, act as a loop antenna. Circulating currents in the loop will create error voltages across any impedances in series with the instrument's input. For this reason, you should apply low-level AC voltages to the instrument through shielded cables. You should also connect the shield to the input LO terminal.

Be sure to minimize the area of any ground loops that cannot be avoided. A high-impedance source is more susceptible to noise pickup than a low-impedance source. You can reduce the high-frequency impedance of a source by placing a capacitor in parallel with the instrument's input terminals. You may have to experiment to determine the correct capacitance value for your application.

Most extraneous noise is not correlated with the input signal. You can determine the error as shown below:

Correlated noise, while rare, is especially detrimental. Correlated noise will always add directly to the input signal. Measuring a low-level signal with the same frequency as the local power line is a common situation that is prone to this error. You should use caution when switching high-level and low-level signals on the same module. It is possible that high-level charged voltages may be discharged onto a low-level channel. It is recommended that you either use two different modules or separate the high-level signals from the low-level signals with an unused channel connected to ground.

Measurements below full scale

You can make the most accurate AC measurements when the internal DMM is at full scale of the selected range. Autoranging occurs at 10 % and 120 % of full scale. This enables you to measure some inputs at full scale on one range and 10% of full scale on the next higher range. Note that the measurement accuracy will be significantly different for the two cases. For highest accuracy, you should use manual ranging to select the lowest range possible for the measurement.

Temperature coefficient and overload errors

The internal DMM uses an AC measurement technique that periodically measures and removes internal offset voltages when you select a different function or range. When manual ranging to a new range in an overload condition, the internal offset measurement may be degraded for the selected range. Typically, an additional 0.01% of range error may be introduced. This additional error will remain until the next periodic removal (typically 15 minutes).

Current measurements

NOTE

Only supported on the DAQM901A multiplexer module

An ammeter senses the current flowing through its input connections – approximating a short circuit between its input terminals. An ammeter must be connected in series with the circuit or device being measured such that current flows through both the meter and the test circuit.

A resistor, R_s in the diagram below, is connected across the input terminals such that a voltage drop proportional to the input current is generated. The value of R_s is selected as low as possible to minimize the instrument's burden voltage, or IR drop. This voltage drop is sensed by the internal DMM and scaled to the proper current value to complete the measurement (see the discussion on the following page).

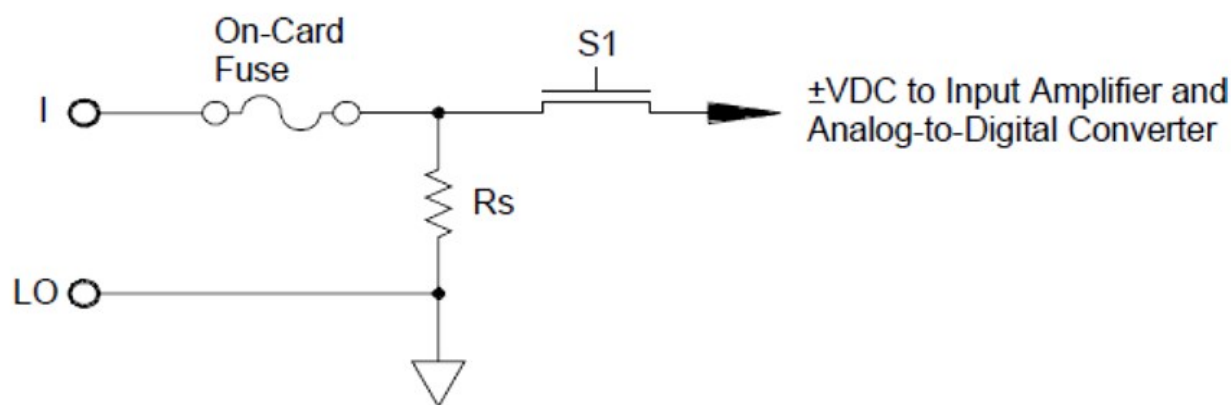

AC current measurements are very similar to DC current measurements. The output of the current-to-voltage sensor is measured by an AC voltmeter. The input terminals are direct coupled (ac+dc coupled) to the shunt so that the internal DMM maintains DC continuity in the test circuit. Performing AC current measurements demands additional care. The burden voltage (loading) varies with frequency and input inductance, often causing unexpected behavior in the test circuit.

Sources of error in DC current measurements

When you connect the internal DMM in series with a test circuit to measure current, a measurement error is introduced. The error is caused by the DMM's series burden voltage. A voltage is developed across the wiring resistance and current shunt resistance of the internal DMM as shown below:

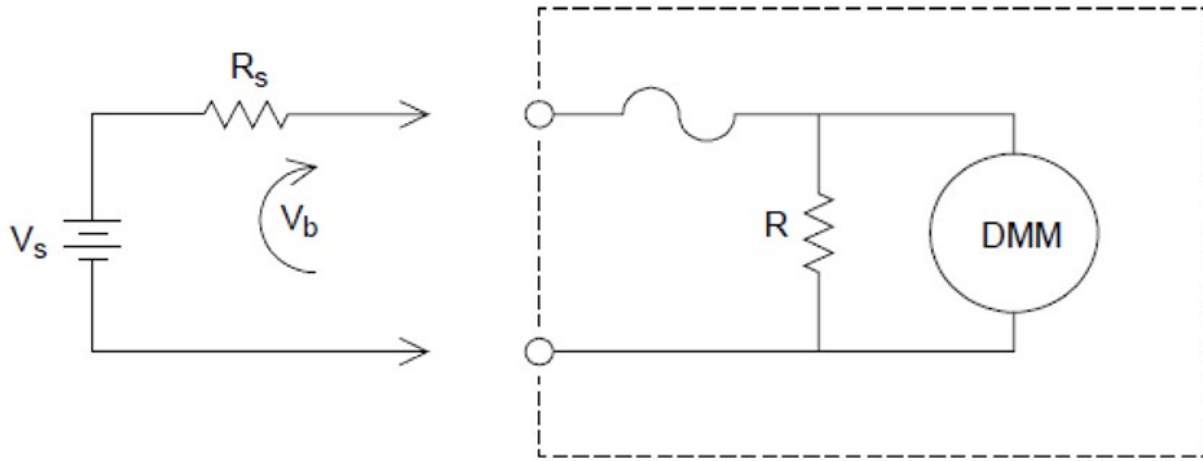

Where:

V_s = Source voltage

R_s = Source resistance

V_b = Current shunt resistance

Sources of error in AC current measurements

Burden voltage errors, which apply to DC current, also apply to AC current measurements. However, the burden voltage for AC current is larger due to the internal DMM's series inductance and the measurement connections. The burden voltage increases as the input frequency increases. Some circuits may oscillate when performing current measurements due to the internal DMM's series inductance and the measurement connections.

Resistance measurement

NOTE

2-wire resistance measurements only supported on the DAQM900A, DAQM901A, DAQM902A, and DAQM908A multiplexer modules.

4-wire resistance measurements only supported on the DAQM900A, DAQM901A, and DAQM902A multiplexer modules.

An ohmmeter measures the DC resistance of a device or circuit connected to its input. Resistance measurements are performed by supplying a known DC current to an unknown resistance and measuring the DC voltage drop.

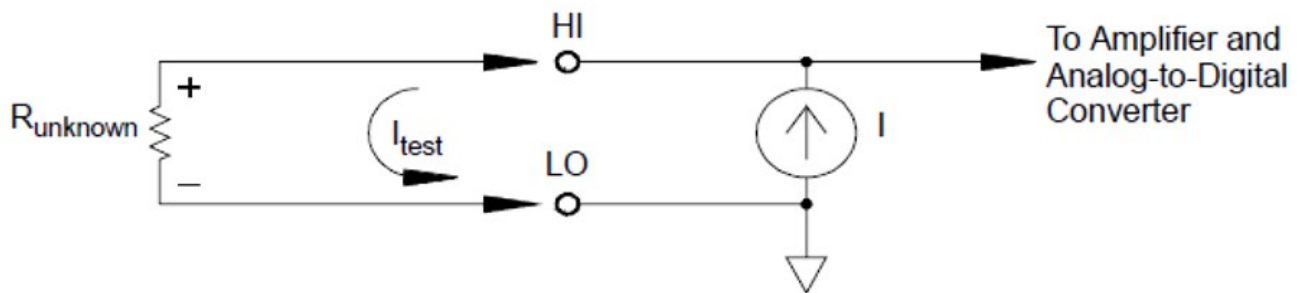

The internal DMM offers two methods for measuring resistance: 2-wire and 4-wire ohms. For both methods, the test current flows from the input HI terminal through the resistor being measured. For 2-wire ohms, the voltage drop across the resistor being measured is sensed internal to the DMM. Therefore, test lead resistance is also measured. For 4-wire ohms, separate “sense” connections are required. Since no current flows in the sense leads, the resistance in these leads does not give a measurement error.

4-Wire Ohms measurements

The 4-wire ohms method provides the most accurate way to measure small resistances. Test lead, multiplexer, and contact resistances are automatically reduced using this method. The 4-wire ohms method is often used in automated test applications where long cable lengths, input connections, and a multiplexer exist between the internal DMM and the device-under-test.

The recommended connections for 4-wire ohms measurements are shown in the diagram on the following page. A constant current source, forcing current I through unknown resistance R , develops a voltage measured by a DC voltage front end. The unknown resistance is then calculated using Ohm’s Law.

The 4-wire ohms method is used in systems where lead resistances can become quite large and variable and in automated test applications where cable lengths can be quite long. The 4-wire ohms method has the obvious disadvantage of requiring twice as many switches and twice as many wires as the 2-wire method. The 4-wire ohms method is used almost exclusively for measuring lower resistance values in any application, especially for values less than $10\ \Omega$ and for high-accuracy requirements such as RTD temperature transducers.

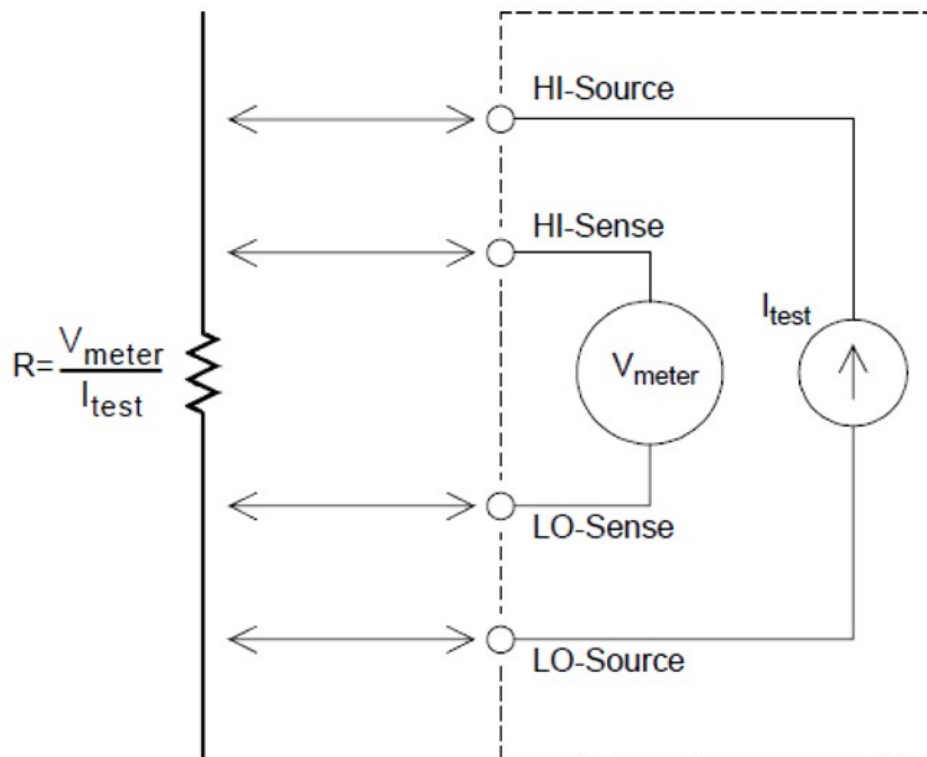

Offset compensation

Most connections in a system use materials that produce small DC voltages due to dissimilar metal-to-metal contact (thermocouple effect) or electrochemical batteries. These DC voltages also add errors to resistance measurements. The offset-compensated measurement is designed to allow resistance measurements in the presence of small DC voltages.

Offset compensation makes two measurements on the circuit connected to the input channel. The first measurement is a conventional resistance measurement. The second is the same except the internal DMM's test current source is turned off (essentially a normal DC voltage measurement). The second measurement is subtracted from the first prior to scaling the result, thus giving a more accurate resistance measurement.

Offset compensation can be used for 2-wire or 4-wire ohms measurements (but not for RTD or thermistor measurements). The DAQ970A/DAQ973A disables offset compensation when the measurement function is changed or after a Factory Reset (*RST command). An Instrument Preset (SYSTEM:PRESet command) or Card Reset (SYSTEM:CPON command) does not change the setting.

If the resistor being measured does not respond quickly to changes in current, offset compensation will not produce an accurate measurement. Resistors with very large inductances or resistors with large parallel capacitance would fall into this category. In these cases, the channel delay parameter can be increased to allow more settling time after the current source is switched on or off, or offset compensation can be turned off.

Sources of error in resistance measurements

External voltages

Any voltages present in the system cabling or connections will affect a resistance measurement. The effects of some of these voltages can be overcome by using offset compensation (as described on the above section).

Settling time effects

The internal DMM has the ability to insert automatic measurement settling delays. These delays are adequate for resistance measurements with less than 200 pF of combined cable and device capacitance. This is particularly important if you are measuring resistances above 100 k Ω . Settling due to RC time constant effects can be quite long. Some precision resistors and multifunction calibrators use large parallel capacitances (1000 pF to 0.1 μ F) with high resistance values to filter out noise currents injected by their internal circuitry. Non-ideal capacitances due to dielectric absorption (soak) effects in cables and other devices may have much longer settling times than expected just by RC time constants. Errors will be measured when settling after the initial connection, after a range change, or when using offset compensation. You may need to increase the channel delay time before a measurement in these situations.

High-resistance measurement errors

When you are measuring large resistances, significant errors can occur due to insulation resistance and surface cleanliness. You should take the necessary precautions to maintain a “clean” high-resistance system. Test leads and fixtures are susceptible to leakage due to moisture absorption in insulating materials and “dirty” surface films. Nylon and PVC are relatively poor insulators (10^9 ohms) when compared to PTFE insulators (10^{13} ohms). Leakage from nylon or PVC insulators can easily contribute a 0.1% error when measuring a 1 M Ω resistance in humid conditions. The table below shows several common insulating materials and their typical resistances.

Insulating material	Resistance range	Moisture absorbing
PTFE	1 T Ω to 1 P Ω	No
Nylon	1 G Ω to 10 T Ω	Yes
PVC	10 G Ω to 10 T Ω	Yes
Polystyrene	100 G Ω to 1 P Ω	No
Ceramic	1 G Ω to 1 P Ω	No
Glass Epoxy (FR-4, G-10)	1 G Ω to 10 T Ω	Yes
Phenolic, Paper	10 M Ω to 10 G Ω	Yes

Strain gage measurements

You can measure a strain gage using a 4-wire resistance measurement with scaling.

When a force is applied to a body, the body deforms. The deformation per unit length is called strain (ϵ). Strain may be either tensile (+) or compressive (-). Practical strain values are usually quite small (typically less than 0.005 inch/inch for most metals) and are often expressed in micro-strains ($\mu\epsilon$). There are three common types of strain measurements as shown below:

1. Normal strain (ϵ)

It is a measure of the deformation along the axis of the applied force, where $\epsilon = \Delta L / L$

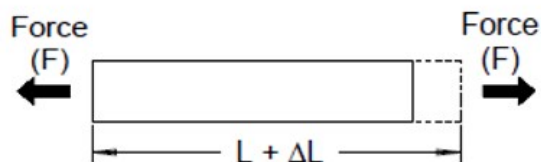

2. Shearing strain (γ)

It is a measure of the angular distortion of a body. It is approximated by the tangent of the angle formed by the angular change between two line segments that were parallel in the undeformed state.

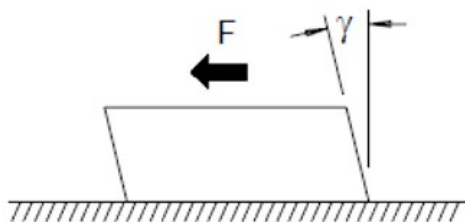

3. Poisson Strain (ν)

It measures a property of materials known as the Poisson Ratio. It is the negative ratio of transverse and longitudinal normal strain when a body has a longitudinal tensile force applied, where $\nu = -\epsilon_t / \epsilon$, where $\epsilon_t = \Delta D / D$ and $\epsilon = \Delta L / L$

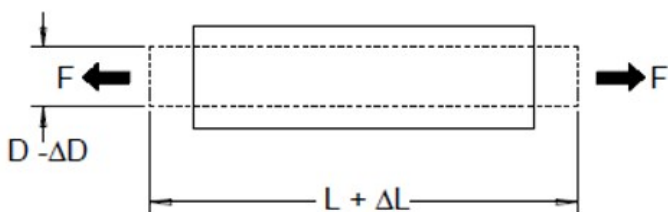

Stress

Stress is a term used to compare the loading applied to a material with its ability to carry the load. Stress (σ) in a material can not be measured directly; it must be computed from material properties and measurable quantities such as strain and force.

Strain sensors

The metal foil resistance strain gage is by far the most widely used strain measurement sensor. It consists of a thin metallic foil grid bonded to a thin insulating, adhesive backing. The resistance of the foil varies linearly with strain. Strain in the test body is simply the ratio of the foil's strained to unstrained resistance: $\epsilon = \Delta R / R$.

Gage Factor (GF)

The Gage Factor (GF) indicates the sensitivity of a strain gage and is a measure of the fractional resistance change per strain: $GF = (\Delta R / R) / \epsilon$. Devices with a higher gage factor will exhibit a greater resistance change per strain applied.

Strain gages are available in various numbers and configurations of elements. The most common element is the single gage form shown below. Multi-element strain gages, also called rosettes, are used to measure components of strain in different directions. Two-element (90°) and three-element (45° or 60°) configurations are the most common.

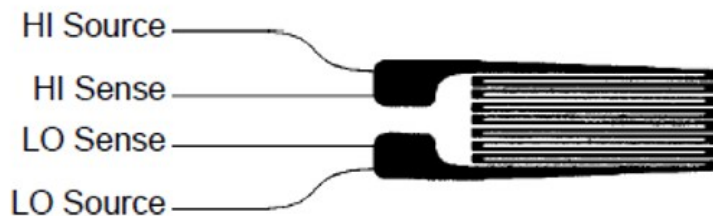

Common uses for strain gages

Strain gages are used to sense many types of physical parameters. Strain gages are primarily a force-sensing device. Force is measured indirectly by measuring the deformation of a test body to a known applied force thus producing a resistance change proportional to the applied force. Many other physical quantities can be measured through force measurements. Common applications of strain gages include weight, pressure, flow, and level measurements.

Making strain gage measurements

A Wheatstone bridge is commonly used to enable instruments with low-sensitivity measuring capabilities to measure small resistance changes common in strain measurements. Instruments with high-resolution resistance measuring capabilities, like the DAQ970A/DAQ973A internal DMM, can directly measure small resistance changes with high precision and linearity. You should also use the 4-wire resistance method when measuring strain gages to eliminate system cabling errors.

An initial, unstrained, gage resistance measurement is used as the reference (R_0) measurement from which strain ($\Delta R / R_0$) is measured. For best results, you should perform this reference measurement after the strain gage has been mounted to the test body. The table below shows the resistance changes corresponding to 1 $\mu\epsilon$ strain for common gage factor and unstrained gage resistance values.

Strain	GF	R_0	ΔR	DMM Sensitivity
1 $\mu\epsilon$	2.0	120 Ω	0.24 m Ω	0.1 m Ω (0.4 $\mu\epsilon$)
1 $\mu\epsilon$	2.0	350 Ω	0.70 m Ω	1.0 m Ω (1.4 $\mu\epsilon$)
1 $\mu\epsilon$	2.0	1000 Ω	2.0 m Ω	1.0 m Ω (0.5 $\mu\epsilon$)

Using the measurement scaling function ($mX+b$) with the equations shown below will allow you to display results directly in strain on the DAQ970A/DAQ973A front-panel display. You can use a custom measurement unit to display readings in " $\mu\epsilon$ " (micro-strain) directly. The instrument will automatically add the micro (" μ ") prefix based upon actual calculated values.

Temperature effects

The resistive element of a strain gage will produce a resistance change ΔR due to measured strain as well as changes in gage temperature. This will create an "apparent" strain change which is undesirable. A second gage of similar type can be used to detect temperature changes and thus remove this error source. You should mount the second gage in close proximity and at 90° to the first gage, thus responding to local temperature changes but rejecting strain changes. Subtracting measurements from the second gage will remove any undesirable strain errors.

Frequency and period measurements

The internal DMM uses a reciprocal counting technique to measure frequency and period. This method generates constant measurement resolution for any input frequency. The internal DMM's AC voltage measurement section performs input signal conditioning for frequency and period measurements.

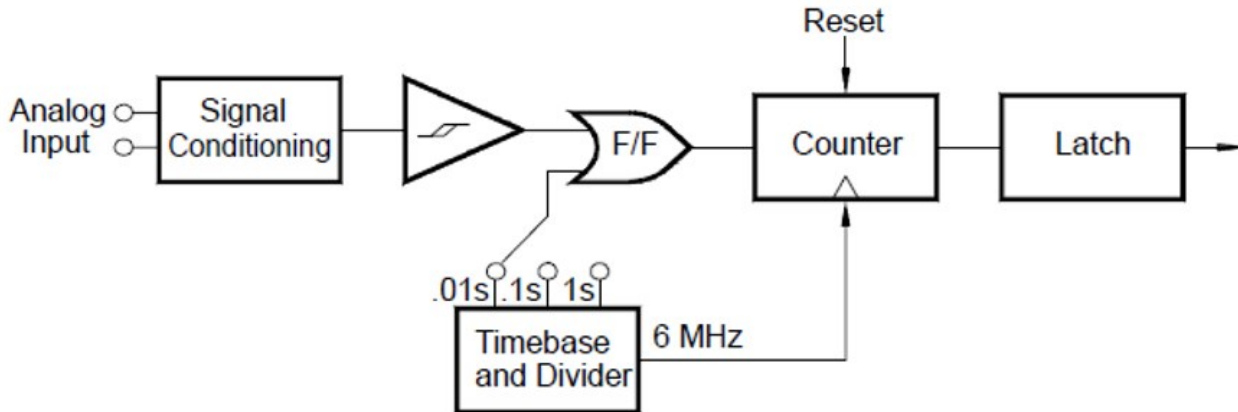

The timebase is divided to provide a gate signal. The gate signal and input signal are combined to enable the counter. During the “on” time, the counter counts the 6 MHz timebase signal. At the end of each gate period, the total count is latched and the result is divided by the known timebase frequency to determine the input frequency. The counter is then reset before the next gate period. The resolution of the measurement is tied to the timebase, and not the input frequency. This increases measurement speed especially at low frequencies.

The reciprocal counter has the advantage of a constant number of digits of display, no matter what the input frequency is. With a reciprocal counter, the number of digits of resolution scales with the gate time. If a 1-second gate gives six digits of resolution, a 0.1-second gate gives five digits, and so forth.

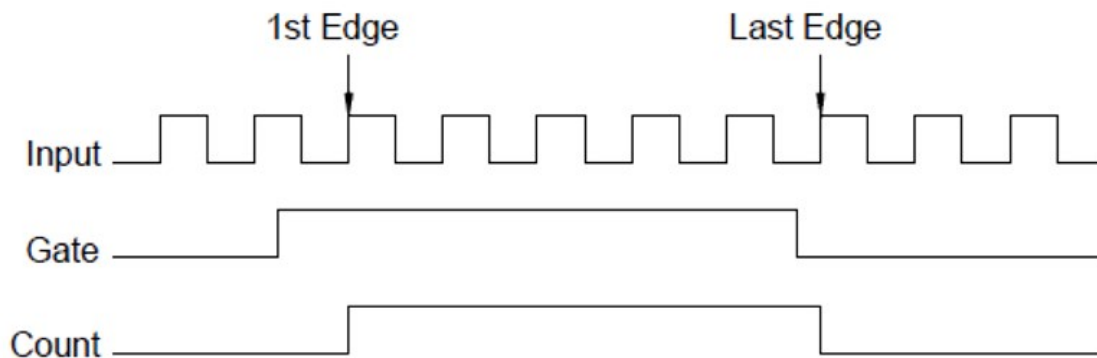

Sources of error in frequency and period measurements

The internal DMM's AC voltage measurement section performs input signal conditioning. All frequency counters are susceptible to errors when measuring low-voltage, low-frequency signals. The effects of both internal noise and external noise pickup are critical when measuring "slow" signals. The error is inversely proportional to frequency. Measurement errors will also occur if you attempt to measure the frequency (or period) of an input following a DC offset voltage change. You must allow the internal DMM's input DC blocking capacitor to fully settle before making frequency measurements.

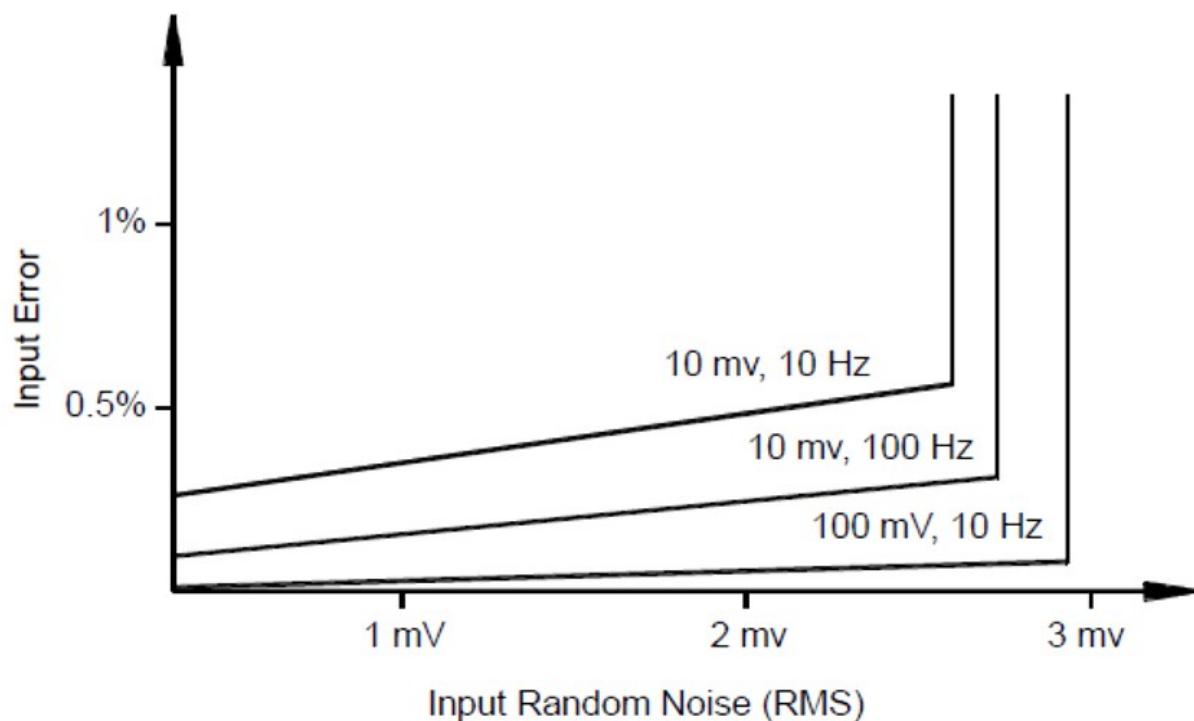

If the external noise pickup becomes large enough to exceed the hysteresis of the measuring circuitry, the frequency function may actually become unusable. External shielding and low-pass filtering may help.

Capacitance measurements

The DAQ970A/DAQ973A makes capacitance measurements by applying a known current to charge the capacitance and then a resistance to discharge as shown below:

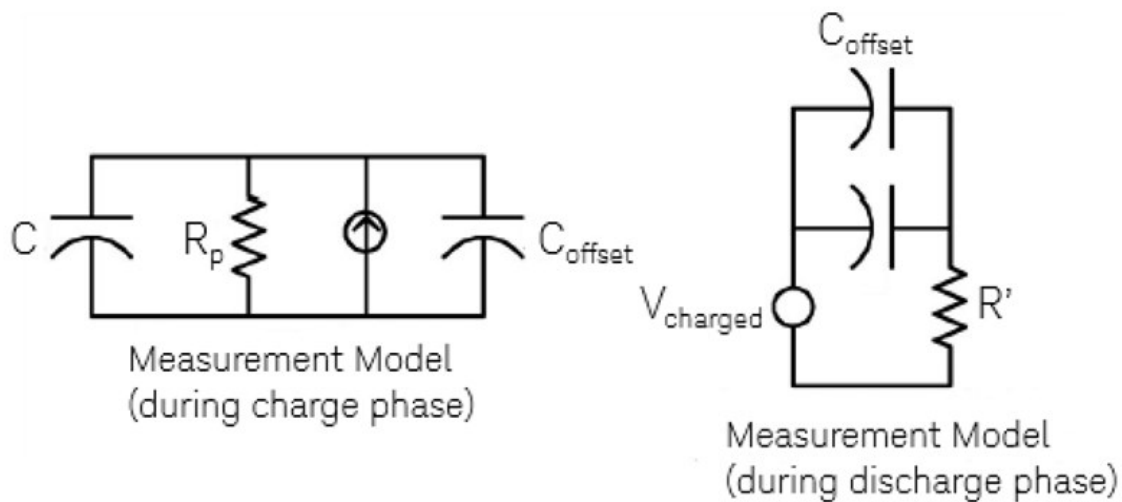

Capacitance is calculated by measuring the change in voltage (DV) that occurs over a “short aperture” time, (Dt). This measurement is repeated at two different times during the exponential rise that occurs. An algorithm takes the data from these four points, and by linearizing that exponential rise over these “short apertures”, accurately calculates the capacitance value.

The measurement cycle consists of two parts: a charge phase (shown in the graph) and a discharge phase. The time-constant during the discharge phase is longer, due to a $100\text{ k}\Omega$ protective resistor in the measurement path. This time-constant plays an important role in the resultant reading rate (measurement time). The incremental times (or “sample times”) as well as the width of the “short apertures”, vary by range, in order to minimize noise and increase reading accuracy. For the best accuracy, take a zero null measurement with open probes, to null out the test lead capacitance, before connecting the probes across the capacitor to be measured.

Capacitance measurement considerations

Capacitors that have a high dissipation factor or other non-ideal characteristics will affect capacitance measurements. Capacitors with high dissipation factors may exhibit a variance between the measured value using the multimeter versus the single frequency method of some other LCR meters. The single frequency method will also see more variation at different frequencies. For example, some inexpensive capacitance substitution boxes, when measured with the multimeter, are almost 5% different compared to the same capacitance measured with the single frequency method of an LCR meter. The LCR meter will also show different values at different frequencies.

Capacitors with long time constants (dielectric absorption) will result in slow measurement settling time, and will take a number of seconds to stabilize. You may see this when first connecting a capacitor or when the delay time to make a measurement is varied. A high quality film capacitor typically shows the least of this and an electrolytic capacitor the most, with ceramic capacitors typically in between.

Digitizing measurements

The digitize mode is available on both DAQ970A/DAQ973A with the **DMM Digitize** data acquisition mode. Digitizing is the process of converting a continuous analog signal, such as a sine wave, into a series of discrete samples (readings). The figure below shows the result of digitizing a sine wave. This chapter discusses the various ways to digitize signals. The importance of the sampling rate, and how to use level triggering.

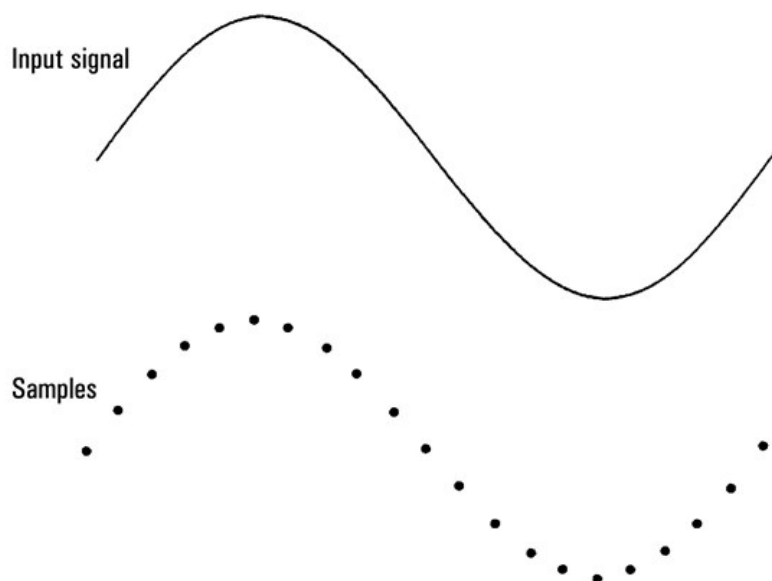

Sampling rate

The Nyquist or Sampling Theorem states: If a continuous, bandwidth-limited signal contains no frequency components higher than F , then the original signal can be recovered without distortion (aliasing) if it is sampled at a rate that is greater than $2F$ samples per second.

In practice, the multimeter's sampling rate must be greater than twice the highest frequency component of the signal being measured. From the front panel you can select a sample rate in samples per second, or select a sample interval (time between samples) by toggling the **Sample** softkey.

The figure below shows a sine wave sampled at a rate slightly less than $2F$. As shown by the dashed line, the result is an alias frequency which is much different than the frequency of the signal being measured. Some digitizers have a built-in anti-aliasing low-pass filter with a sharp cutoff at a frequency equal to $1/2$ the digitizer's sampling rate. This limits the bandwidth of the input signal so that aliasing cannot occur. Since the multimeter has a variable sample rate for DCV digitizing, and to preserve the upper bandwidth for high-frequency measurements, no anti-aliasing filter is provided in the multimeter. If you are concerned about aliasing, you should add an external anti-aliasing filter.

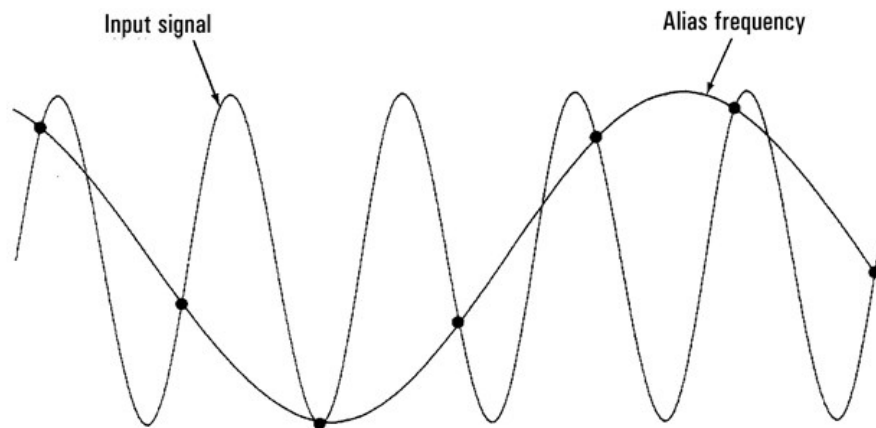

Some digitizers have a built-in anti-aliasing low-pass filter with a sharp cutoff at a frequency equal to $1/2$ the digitizer's sampling rate. This limits the bandwidth of the input signal so that aliasing cannot occur. Since the multimeter has a variable sample rate for DCV digitizing, and to preserve the upper bandwidth for high-frequency measurements, no anti-aliasing filter is provided in the multimeter. If you are concerned about aliasing, you should add an external anti-aliasing filter.

Level triggering

When digitizing, it is important to begin sampling at some defined point on the input signal such as when the signal crosses zero volts or when it reaches the midpoint of its positive or negative peak amplitude. Level triggering allows you to specify when (with respect to voltage and slope) to begin sampling. Refer to [Level triggering](#) for more information.

About DMM Digitize mode

- DMM Digitize mode is available for both DAQ970A/DAQ973A.
- DMM Digitize allows you to take samples of the input signal, at a specified **Sample Rate** (for example, 50 kHz) or **Sample Interval** (for example, 20 μ S). You can specify the Duration as either an amount of Time or a number of Readings (samples). You can use either auto, external, or level triggering. After pressing **[Home]**, press **Acquire** > **DMM Digitize**. You can then select the digitizing/triggering parameters. After configuring the digitizing parameters, press **[Scan/Start]**. Digitizing will begin when the specified trigger event occurs.
- The DMM Digitize option enables pretriggering, level triggering, and trigger delay capability.
- For pretrigger, if a trigger comes before all pretriggers are received, trigger is executed to begin readings.
- All samples taken during digitizing are saved in volatile memory. After completing a digitize operation, press **[Save Recall]** > **Save** > **Readings** softkey and specify a file to save the digitized readings to a file.
- The maximum number of readings that can be captured is based on volatile memory space available.
- Reading stored is cleared at the start of a new acquisition.

Level triggering

Level triggering allows you to trigger measurements at some defined point on the input signal, such as when the signal crosses zero volts or when it reaches the midpoint of its positive or negative peak amplitude. For example, this graphic shows sampling beginning as the input signal crosses 0V with a positive slope:

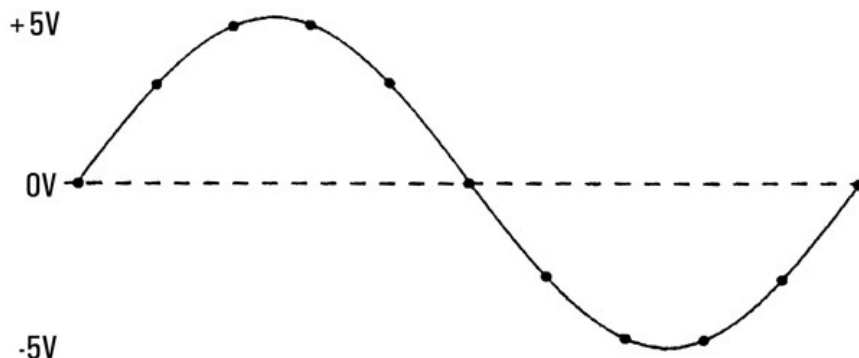

About level trigger

Level triggering is available for these measurement functions:

- DC voltage and DC current
- Strain
- 2-wire and 4-wire resistance with offset compensation off, and low power off
- Temperature (RTD sensor only)

The level trigger is edge-sensitive. That is, the instrument must detect a change in the quantity being measured from one side of the level setting to the other side (direction controlled by Slope setting). For example, if the Slope is positive, then the quantity being measured must first reach a value below the set level before a trigger event can be detected. Level trigger performance is not uniform. Its accuracy, latency, and sensitivity are dependent on other DMM features.

Low-Level Signal Multiplexing and Switching

Low-level multiplexers are available in the following types: one-wire, 2-wire, and 4-wire. The following sections in this chapter describe each type of multiplexer. The following low-level multiplexer modules are available with the DAQ970A/DAQ973A.

- DAQM900A 20-Channel FET Multiplexer
- DAQM901A 20-Channel Armature Multiplexer
- DAQM902A 16-Channel Reed Multiplexer
- DAQM908A 40-Channel Single-Ended Multiplexer

An important feature of a multiplexer used as a DMM input channel is that only one channel is connected at a time. For example, using a multiplexer module and the internal DMM, you can configure a voltage measurement on channel 1 and a temperature measurement on channel 2. The instrument first closes the channel 1 relay, makes the voltage measurement, and then opens the relay before moving on to channel 2 (called break-before-make switching).

- DAQM903A 20-Channel Actuator
- DAQM904A 4×8 Two-Wire Matrix

One-wire (single-ended) multiplexers

On the DAQM908A multiplexer, all of the 40 channels switch the HI input only, with a common LO for the module.

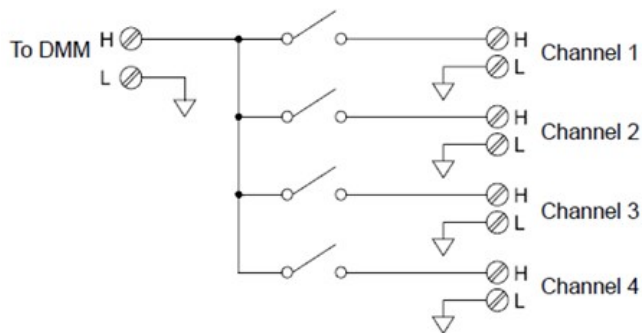

NOTE

Only one channel can be closed at a time; closing one channel will open the previously closed channel.

Two-wire multiplexers

The DAQM900A, DAQM901A, and DAQM902A multiplexers switch both HI and LO inputs, thus providing fully isolated inputs to the internal DMM or an external instrument. These modules also provide a thermocouple reference junction for making thermocouple measurements.

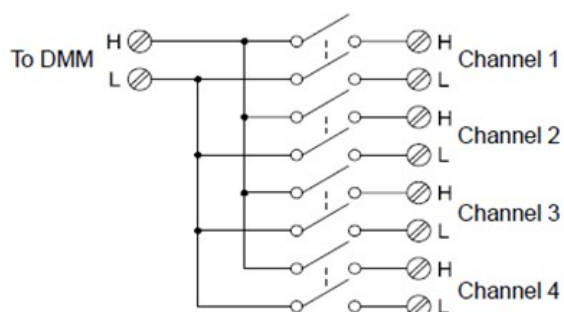

Four-wire multiplexers

You can make 4-wire ohms measurements using the DAQM900A, DAQM901A, and DAQM902A multiplexers. For a 4-wire ohms measurement, the channels are divided into two independent banks by opening the bank relay.

For 4-wire measurements, the instrument automatically pairs channel n with channel $n+10$ (DAQM901A) or $n+8$ (DAQM902A) to provide the source and sense connections. For example, make the source connections to the HI and LO terminals on channel 2 and the sense connections to the HI and LO terminals on channel 12.

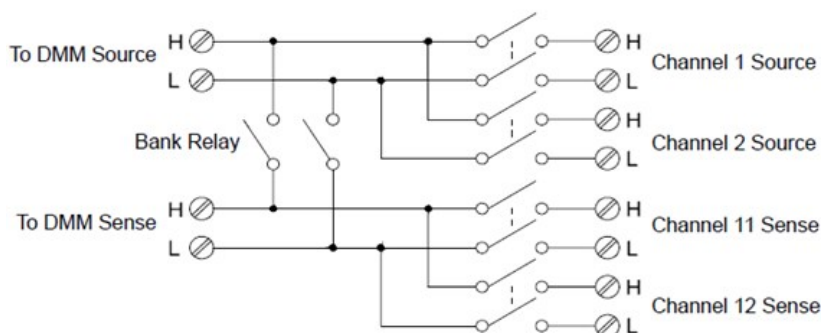

NOTE

If any channels are configured to be part of the scan list, you cannot close multiple channels; closing one channel will open the previously closed channel.

When making a 4-wire measurement, the test current flows through the source connections from the HI terminal through the resistor being measured. To eliminate the test lead resistance, a separate set of sense connections are used as shown below:

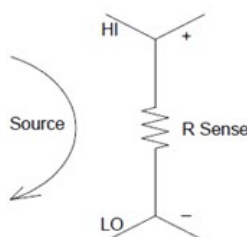

Signal routing and multiplexing

When used stand-alone for signal routing (not scanning or connected to the internal DMM), multiple channels on the DAQM901A and DAQM902A multiplexers can be closed at the same time. You must be careful that this does not create a hazardous condition (for example, connecting two power sources together).

Note that a multiplexer is not directional. For example, you can use a multiplexer with a source (such as a DAC) to connect a single source to multiple test points as shown below:

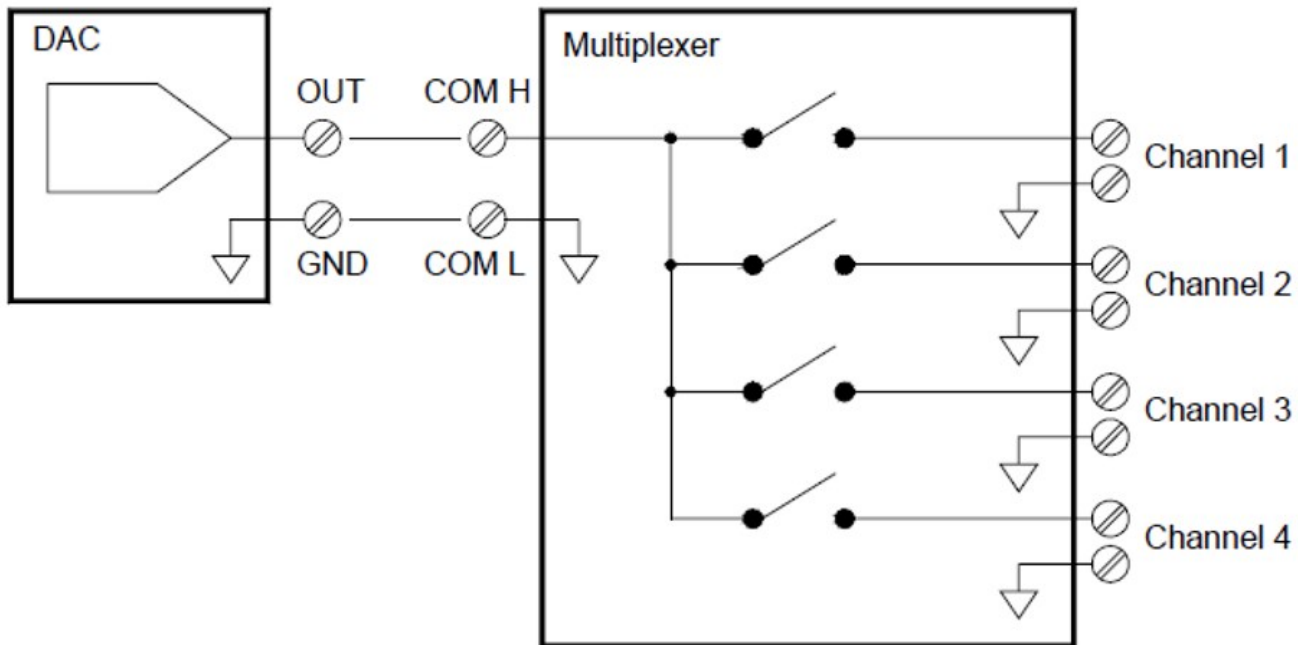

Sources of error in multiplexing and switching

Noise can be coupled inside a switch by the drive circuitry, by switch thermal EMFs, or by coupling among signal paths. Noise can also be generated outside the network and conducted or coupled into the switch. Although noise problems apply to the entire system, they can become especially acute for switching. Switch networks contain a high concentration of signals, which magnify the errors. Most problems with electric noise can be traced to improper grounding and shielding.

Noise can be capacitively coupled between physically adjacent channels in a switching system. Noise can be coupled between the switch contacts themselves (C_{sw}) or between adjacent cabling (C_{adj}).

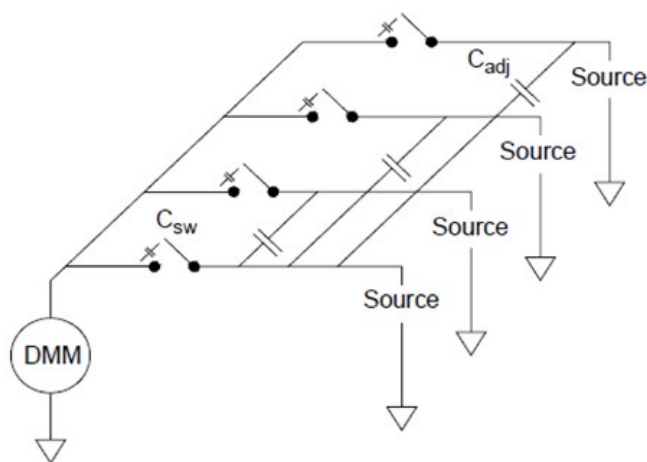

Capacitive noise coupling is a function of area and proximity. A simple method to reduce the noise coupling is to physically separate the switches and cables from each other. However, this may not be practical for all applications.

Another solution is to keep large amplitude signals and small amplitude signals away from each other. Group similar signals together (high voltages, low voltages, analog, and digital). If possible, use two separate switch modules; one for high-level signals and one for low-level signals. If you are using a single module for mixed-signal switching, leave one unused, grounded channel between the groups. Also, ground any unused channels on the module.

The DAQM901A and DAQM902A multiplexers have an additional relay, called a bank switch or tree switch, which helps reduce channel-to-channel noise (C_{adj}). The multiplexer channels are divided into two banks. The bank switch isolates one bank of channels from the other, effectively removing any parallel adjacent capacitance from the isolated bank. During a scan, the instrument automatically controls the bank switches.

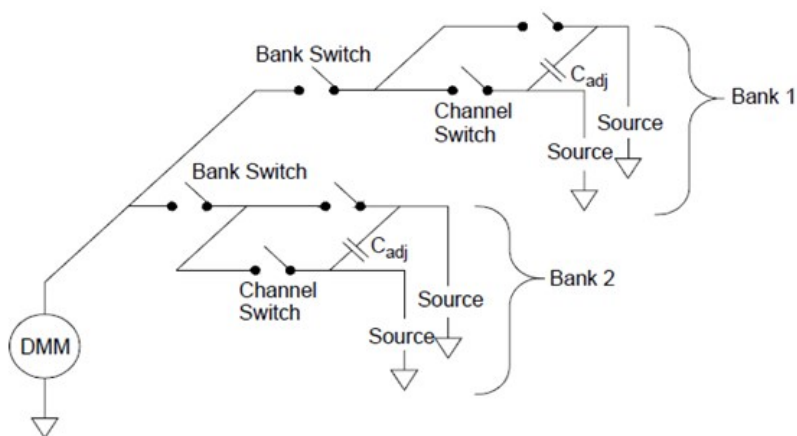

Module	Bank 1	Banks 2
DAQM900A	Channels 1 through 10	Channels 11 through 20
DAQM901A	Channels 1 through 10	Channels 11 through 20
DAQM902A	Channels 1 through 8	Channels 9 through 16
DAQM908A	Channels 1 through 20	Channels 21 through 40

Actuators and General-Purpose Switching

The DAQM903A Actuator provides 20 independent, isolated SPDT (single-pole, double-throw) or Form C switches. This module offers simple on-off switching which you can use to control power devices or for custom switching applications. For example, you can use an actuator to build a simple resistance ladder as shown below:

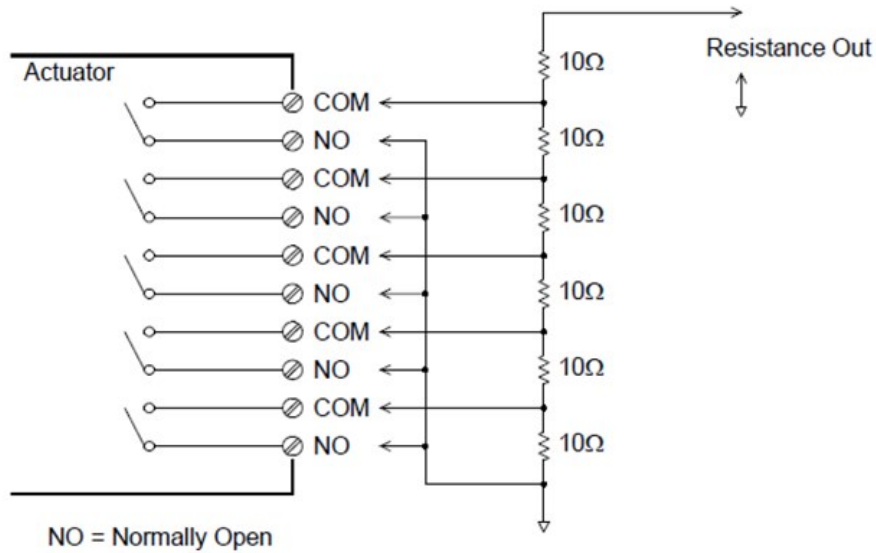

In the above diagram, the resistance is $60\ \Omega$ when all of the actuator channels are open (not connected to COM). Note that when the actuator channels are open, as shown above, the normally-closed contacts (not shown above) are connected to COM. Values from $10\ \Omega$ to $50\ \Omega$ are selected by closing the appropriate channel(s) on the module.

Snubber circuits

Whenever a relay contact opens or closes, electrical breakdown or arcing can occur between the contacts. This can cause high-frequency noise radiation, voltage and current surges, and physical damage to the relay contacts.

A breadboard area is provided on the DAQM903A to implement custom circuitry such as simple filters, snubbers, and voltage dividers. The breadboard area provides the space necessary to insert your own components but there are no circuit board traces here. You can build these networks to provide contact protection when actuating AC power line for reactive loads. Although many types of contact protection networks can be used, only RC networks and varistors are described in this section.

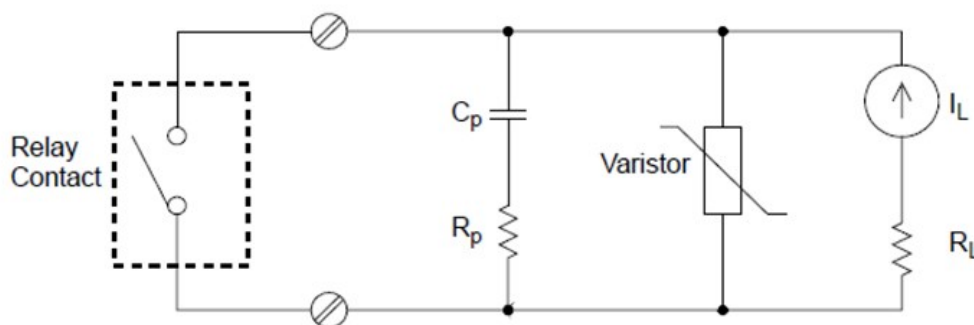

RC protection network

When designing RC protection networks, the protection resistor R_p is selected as a compromise between two resistance values. The minimum value of R_p is determined by the maximum acceptable relay contact current (I_{max}). For the DAQM903A, the maximum allowable relay current (I_{max}) is 1 ADC or AC rms. Thus, the minimum value for R_p is V/I_o , where V is the peak value of the supply voltage.

The maximum value for R_p is usually made equal to the load resistance R_L . Therefore, the limits on R_p can be stated as:

Note that the actual value of the current (I_o) in a circuit is determined by the equation:

where V is the peak value of the source voltage and R_L is the resistance of the load. The value for I_o will be used to determine the value of the protection capacitor (C_p).

In determining the value of the protection network capacitor (C_p), there are several things that you will need to consider. First, the total circuit capacitance (C_{tot}) must be such that the peak voltage across the open relay contacts does not exceed 300 Vrms. The equation for determining the minimum allowable circuit capacitance is:

where L is the inductance of the load and I_o is the current value calculated earlier.

The total circuit capacitance (C) is actually made up of the wiring capacitance plus the value of the protection network capacitor (C_p). Therefore, the minimum value for C_p should be the value obtained for the total circuit capacitance (C). Note that the actual value used for C_p should be substantially greater than the value calculated for C .

Using Varistors

Use a varistor to add an absolute voltage limit across the relay contacts. Varistors are available for a wide range of voltage and clamp energy ratings. Once the circuit reaches the voltage rating of the varistor, the varistor's resistance declines rapidly. A varistor can supplement an RC network and is especially useful when the required capacitance (C_p) is too large.

Using Attenuators

Provisions have been made on the DAQM903A circuit board for installing simple attenuators or filter networks. An attenuator is composed of two resistors that act as a voltage divider. A typical attenuator circuit is shown below:

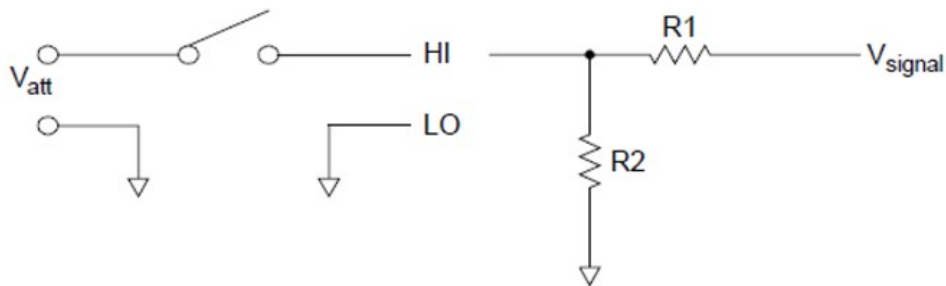

To select the attenuator components, use the following equation:

One typical use for the shunt component is with 4 to 20 mA transducers. A $50\ \Omega$, $\pm 1\%$, 0.5 watt resistor can be installed in the R2 location. The resultant voltage drop (transducer current through the resistor) can be measured by the internal DMM. Thus, the $50\ \Omega$ resistor converts the 4 to 20 mA current to a 0.2 to 1 volt signal.

Matrix Switching

A matrix switch connects multiple inputs to multiple outputs and therefore offers more switching flexibility than a multiplexer. Use a matrix for switching low-frequency (less than 10 MHz) signals only. A matrix is arranged in rows and columns. For example, a simple 3x3 matrix could be used to connect three sources to three test points as shown below:

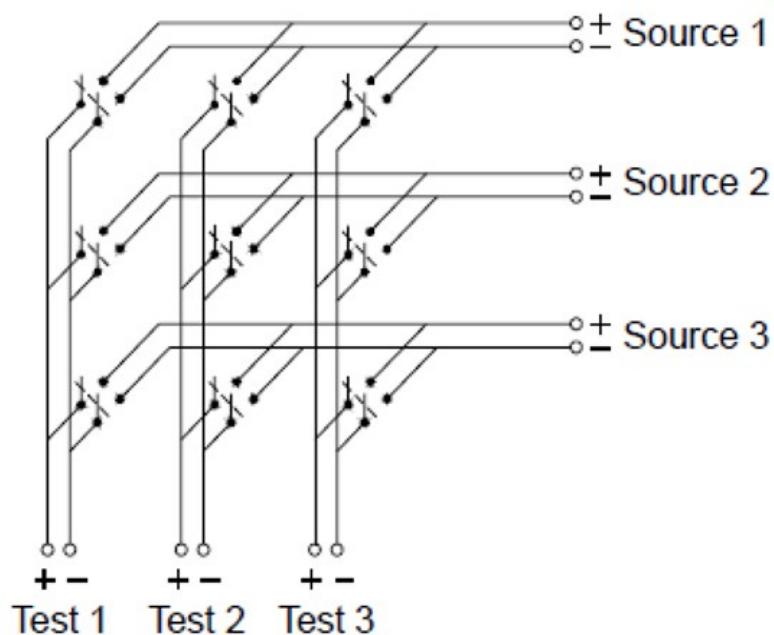

Any one of the signal sources can be connected to any one of the test inputs. Be aware that with a matrix, it is possible to connect more than one source at the same time. It is important to make sure that dangerous or unwanted conditions are not created by these connections.

Combining Matrices

You can combine two or more matrix switches to provide more complex switching. For example, the DAQM904A provides a 4-row by 8-column matrix. You can combine two of these modules as either a 4-row by 16-column matrix or an 8-row by 8-column matrix. An 8x8 matrix is shown below:

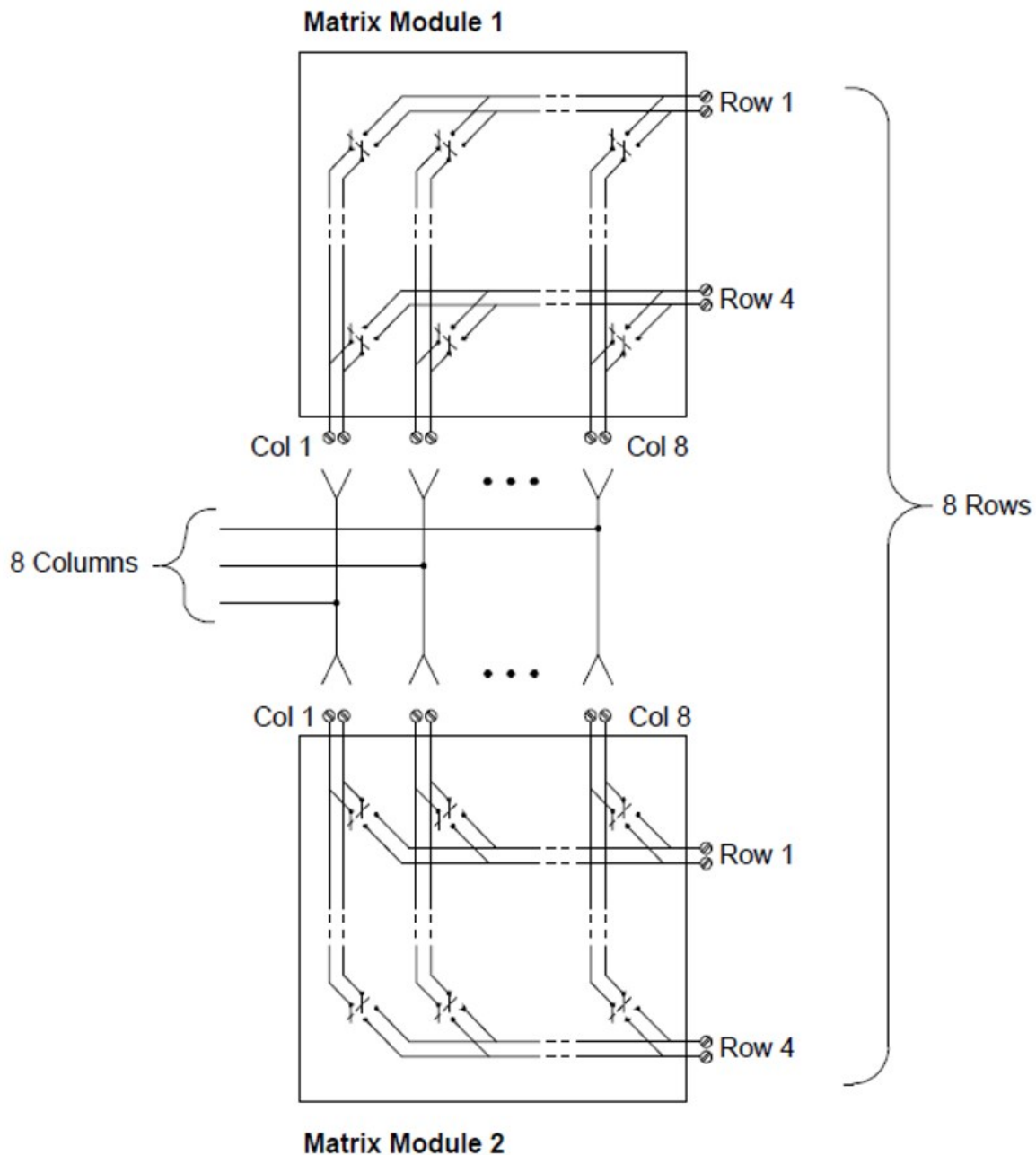

RF Signal Multiplexing

A special type of multiplexer is the RF multiplexer. This type of multiplexer uses special components to maintain a 50 Ω impedance in the signal line being switched. In a test system, these switches are often used to route a test signal from a signal source to the device-under-test. The switches are bi-directional. The diagram below shows two examples of a 4-to-1 channel RF multiplexer in a test system.

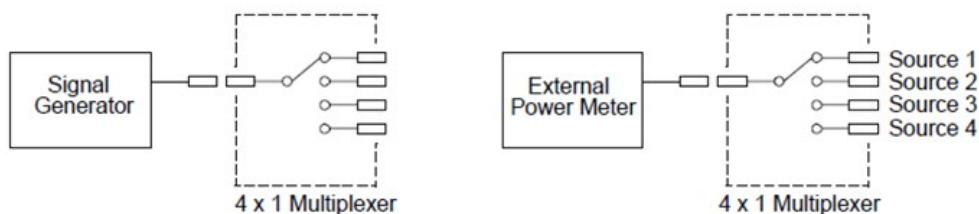

By using patch cables, you can expand RF multiplexers to provide additional test inputs or outputs. For example, you can combine two 4-to-1 multiplexers to create a 7-to-1 multiplexer as shown below:

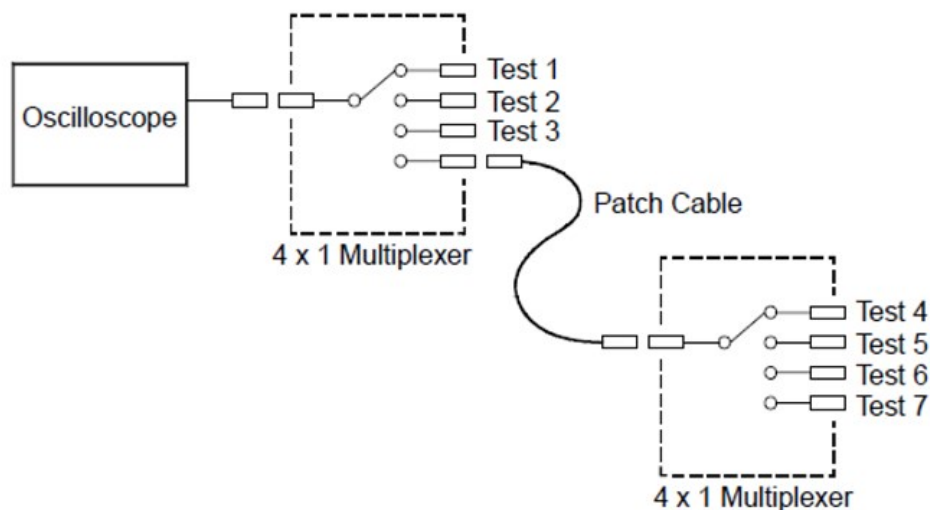

On the DAQM905A (50 Ω) RF multiplexers, you can close only one channel per bank at a time; closing one channel in a bank will open the previously closed channel. These modules respond only to the CLOSE command (OPEN does not apply). To open a channel, send the CLOSE command to another channel in the same bank. Note that DAQM905A module do not automatically terminate open channel.

Sources of error in RF switching

Impedance mismatching can cause a variety of errors in an RF multiplexing system. These errors can cause distorted waveforms, overvoltage, or undervoltage conditions.

To minimize RF impedance mismatching:

- Use the correct cable and connector for the circuit impedance ($50\ \Omega$).
- Be sure that all leads and signal paths are properly terminated. Unterminated sections of line can appear as near shorts at RF frequencies.

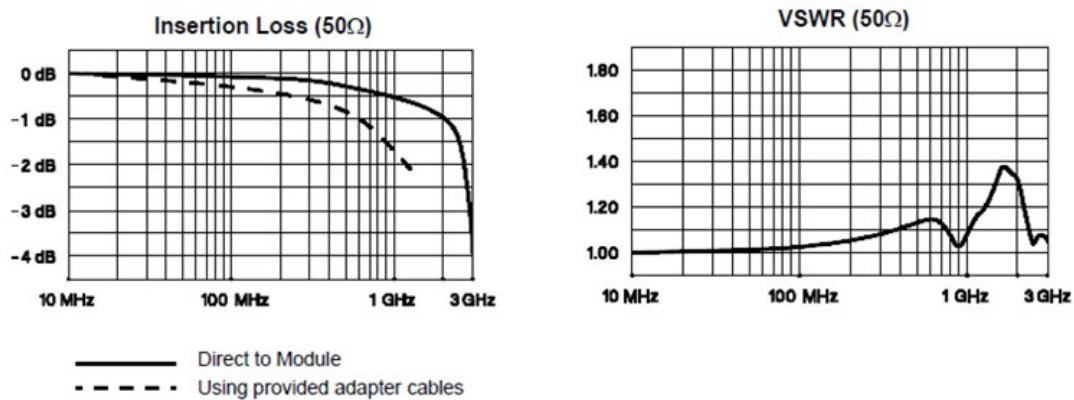

Multifunction Module

Digital Input

The DAQM907A module has two non-isolated 8-bit input/output ports which you can use for reading digital patterns.

- You can read the live status of the bits on the port or you can configure a scan to include a digital read.
- You can generate an alarm when a specific bit pattern or bit pattern change is detected on an input channel. The channels do not have to be part of the scan list to generate an alarm.
- The internal +5 V pull-up circuitry allows you to use the digital input to detect contacts closures like micro-switches or limit switches. An open input floats to +5 V and is read as a "1". An input shorted to ground is read as a "0". An example of a contact close detection channel is shown below:

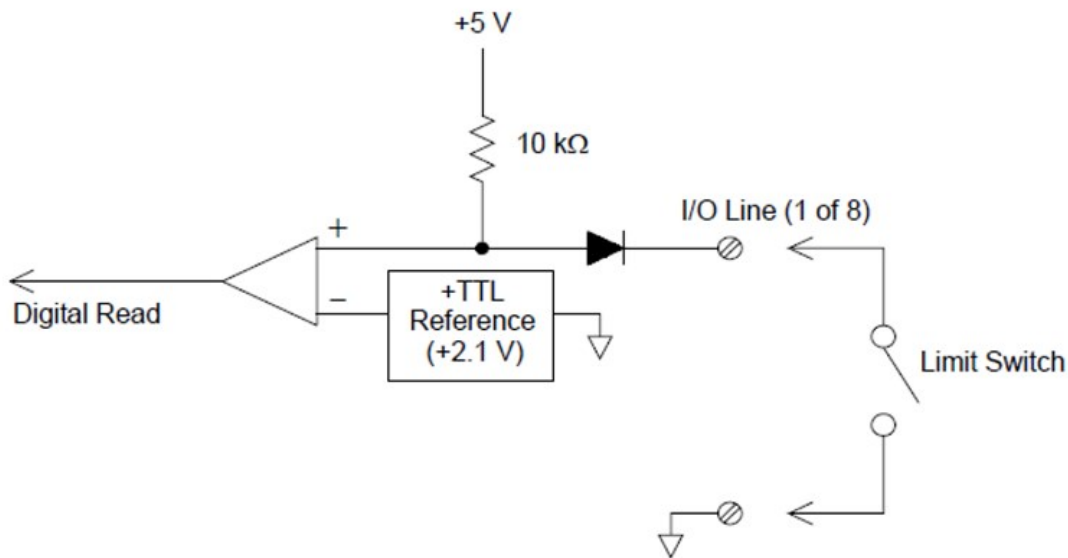

Digital Output

The DAQM907A module has two non-isolated 8-bit input/output ports, which you can use for outputting digital patterns. You can combine the two ports to output a 16-bit word. A simplified diagram of a single output bit is shown below:

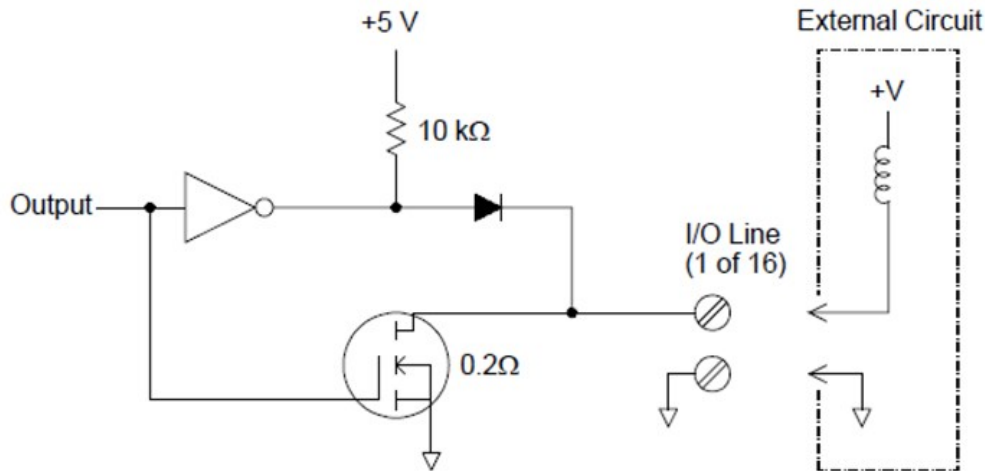

- Each output bit is capable of directly driving up to 10 TTL loads (less than 1 mA). The buffer for each port is used to drive a high output from the internal +5 V supply through the diode. The drive is rated at +2.4 V minimum at 1 mA.
- Each output bit is also can active sink, capable of sinking up to 400 mA from the external power supply. The FET is used to sink currents and has a nominal "on" resistance of 0.2 Ω .
- For non-TTL logic you must provide an external pull-up. A description of the pull-up calculation is given on the following section.
- If used with an external power supply and pull-up, the external supply must be greater than +5 VDC and less than +42 VDC.

Using external pull-up

In general, an external pull-up is required only when you want to set the output “high” value greater than TTL levels. For example, to use a +12V external power supply, the value of the external pull-up resistor is calculated as follows:

The value of the logic "high" level with the external 24 k Ω pull-up resistor is calculated as follows:

Driving external switches

You can use two digital output channels to control an external switch. For example, you can drive the Keysight 876X series of microwave switches using an external power supply and two digital output channels. The state of the 2-to-1 multiplexer is changed by setting the appropriate output bit low (0).

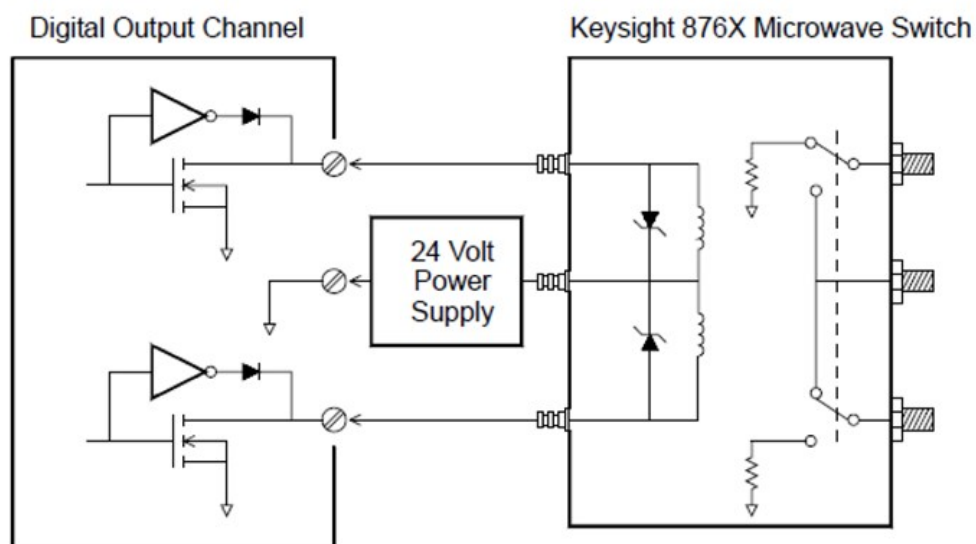

Totalizer

The DAQM907A module has a 26-bit totalizer which can count pulses at a 100 kHz rate. You can manually read the totalizer count or you can configure a scan to read the count.

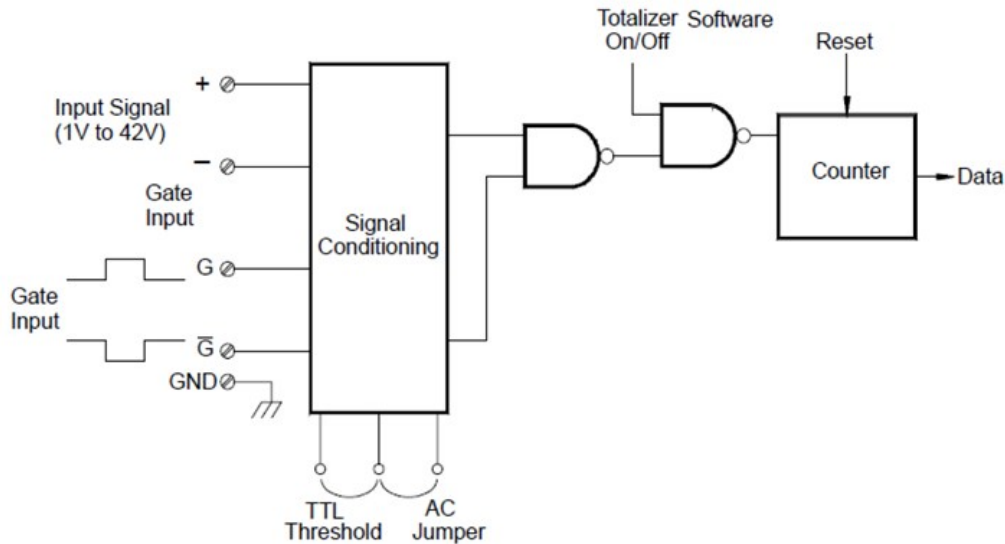

You can configure the totalizer to count on the rising edge or falling edge of the input signal.

Using the hardware jumper labeled "Totalize Threshold" on the module, you can control the threshold at which an edge is detected. Move the jumper to the "AC" position to detect changes through 0 volts. Move the jumper to the "TTL" position (factory setting) to detect changes through TTL threshold levels.

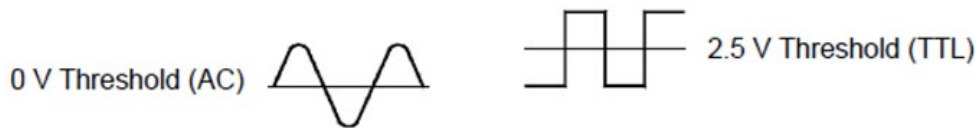

The maximum count is 67,108,863 (2²⁶-1). The count rolls over to "0" after reaching the maximum allowed value.

You can control when the totalizer actually records counts by providing a gate signal (and terminals on the module). A TTL high signal applied to the "G" terminal enables counting and a low signal disables counting. A TTL low signal applied to the terminal enables counting and a high signal disables counting. The totalizer only counts when both terminals are enabled. You can use the either G terminal, the terminal, or both. When a gate is not connected, the gate terminal floats to the enabled state, effectively creating a "gate always" condition.

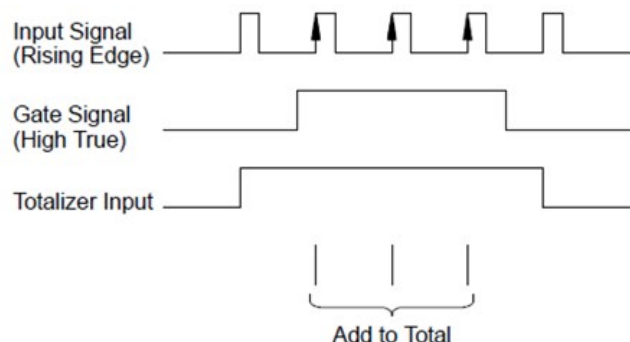

Totalizer errors

Noise on the totalizer input can be a problem, especially on signals with a slow rise time. This noise can create a false indication of a threshold crossing. See [System Cabling and Connections](#) for more information.

Contact bounce on external switches can create false counts. All mechanical switches bounce when they open and close. Use an external capacitor to filter the contact bounce.

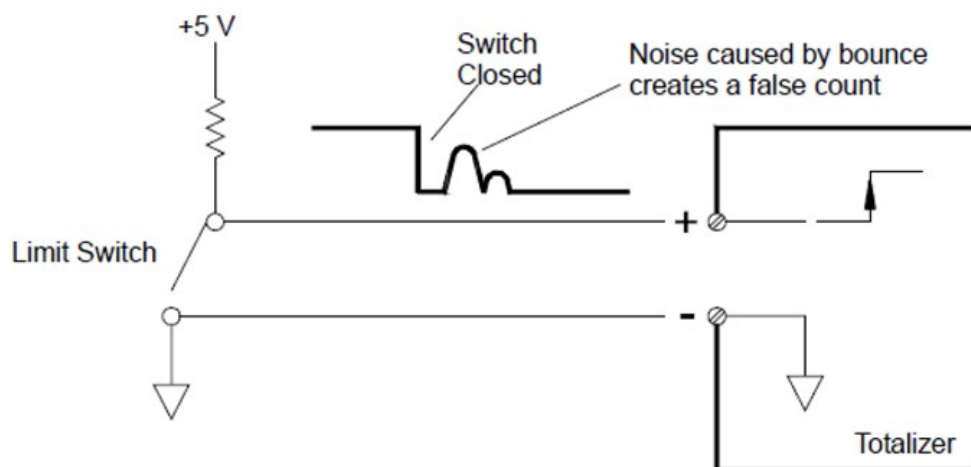

Analog Output (DAC)

The DAQM907A module has two analog outputs and senses capable of outputting calibrated voltages or currents with 18 bits of resolution.

Each DAC (Digital-to-Analog Converter) channel can be used as a programmable voltage or current source for analog input to other devices.

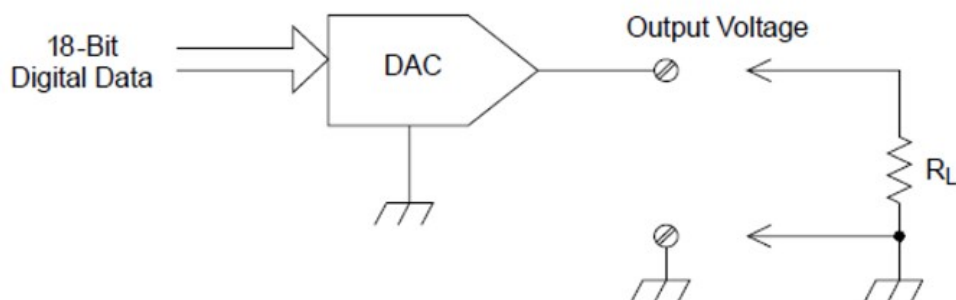

You can set the output voltage to any value between +12 VDC and -12 VDC, in 0.1 mV steps. Each DAC is earth referenced; it cannot float.

Each DAC channel is capable of supplying 15 mA maximum current.

NOTE

You must limit the DAC output current to 40 mA total for each slot (two DAC channels).

To maintain the rated output accuracy, the load (R_L in the diagram shown above) must be greater than 1 k Ω .

DAC errors

The output of a DAC varies with temperature. If possible, you should operate the instrument at a stable temperature and as close as possible to the calibration temperature of the DAC for greater accuracy, or perform autocalibration to recalibrate the DAC if the temperature has changed much from calibration temperature.

The output of a DAC also exhibits two other types of errors: differential error and integral error.

Types of errors	Description
Differential error	Refers to the smallest possible change in voltage. The DAC output is not linear, but is stepped as progressively larger (or smaller) voltages are programmed. The step is in $100\ \mu\text{V}$.
Integral error	Refers to the difference between the programmed voltage and the actual output voltage from the DAC.

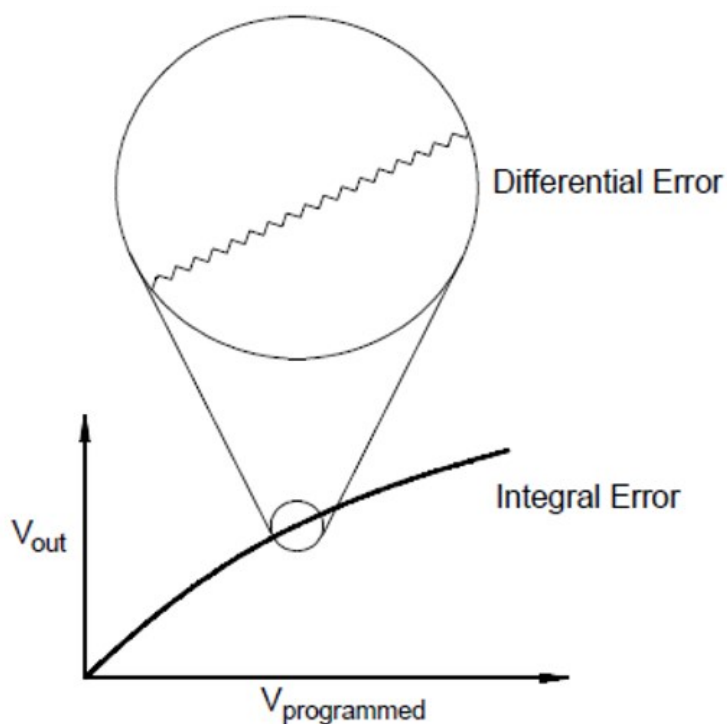

Relay Life and Preventive Maintenance

The DAQ970A/DAQ973A Relay Maintenance System automatically counts the cycles on each relay in the instrument and stores the total count in nonvolatile memory on each switch module. Use this feature to track relay failures and predict system maintenance requirements.

Relays are electromechanical devices which are subject to wear-out failure modes. The life of a relay, or the number of actual operations before failure, is dependent upon how it is used – applied load, switching frequency, and environment.

You can use the graphs shown in this section to estimate relay lifetimes for your application. Additional background information is also provided to give you a better understanding of relay wear-out mechanisms. In general, relay lifetimes depend heavily upon the signals that are being switched and the types of measurements being performed.

- Switching typical signal levels will result in relay lifetimes from 1,000,000 to 10,000,000 operations.
- High-power switching (>25% rating) or high-voltage switching (>100 V) applications will yield relay lifetimes from 100,000 to 1,000,000 operations.
- Low-voltage switching (<25% rating) and low-current switching (<10 mA) applications will yield relay lifetimes to 10,000,000 operations.
- RF switching applications seldom exhibit relay lifetimes exceeding 1,000,000 operations due to more stringent constant resistance requirements (typically less than 0.2 Ω).

The following table shows the time required to reach the specified number of switch operations for several switching speeds.

Continuous switching speed	Switching operations		
	100,000	1,000,000	10,000,000
1 / hour	12 years	N/A	N/A
1 / minute	10 weeks	2 years	N/A
1 / second	1 day	12 days	4 months
10 / second	3 hours	1 day	12 days

Relay life

As a relay is used, the contacts begin to wear and the resistance of the closed contacts increases. The initial contact resistance of a relay is typically 50 mΩ (plus lead resistance). When the contact resistance exceeds 20 to 50 times its initial value, the contact resistance becomes very erratic and the relay should probably be replaced. For most applications, a relay with contact resistance greater than 1 Ω should be replaced. The graph below shows the typical contact resistance characteristics of the relays used on the DAQ970A/DAQ973A switching modules.

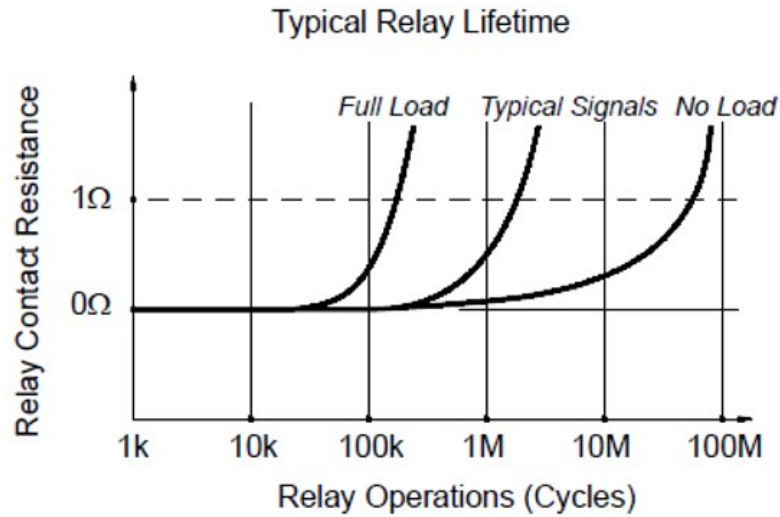

Relay load

For most applications, the load switched by the relay is the most important factor affecting relay life. As shown in the graph below, relay life is maximized by switching low power. As the power switched increases, relay life deteriorates.

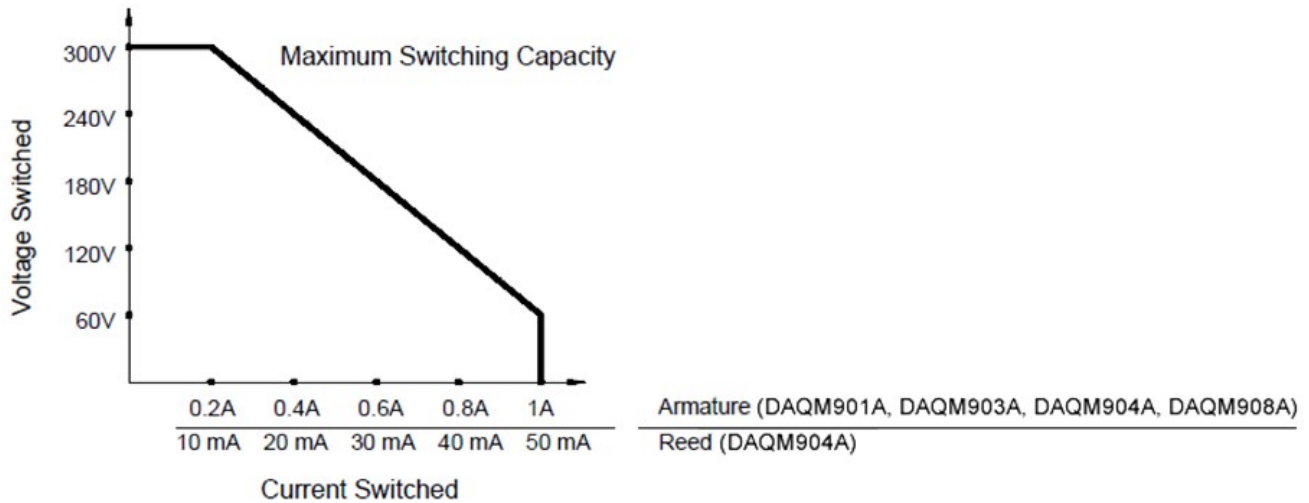

Switching frequency

Relay contacts heat up as they switch significant power. The heat is dissipated through the leads and the body of the relay. As you increase the switching frequency to near its maximum, heat cannot dissipate before the next cycle. The contact temperature rises and the life of the relay is reduced.

Replacement strategy

There are essentially two strategies that you can use for preventive maintenance of the relays on the switching modules. The strategy that you choose depends upon your application, the consequences of a relay failure in your system, and the number of relay cycles during a measurement session.

The first strategy is to replace each relay as needed after it fails or becomes erratic. This is suitable if you are switching higher loads on only a few relays on the module. The disadvantage of this strategy is the inconvenience of continually replacing relays as they near the end of their life at different times.

The second strategy is to replace all relays on the module or simply purchase a new module as the relays near the end of their life. This strategy is best suited for those applications where all relays on the module are switching similar loads. The failure of several relays over a relatively short period of time may indicate impending failures on other relays switching similar loads. This strategy decreases the risk of failure during actual use at the expense of replacing some relays that may have useful life remaining.

NOTE

For switching frequency and replacement strategy as described above, you can use the DAQ970A/DAQ973A Relay Maintenance System to track and even predict relay failures.

This information is subject to change
without notice.

© Keysight Technologies 2019-2020

Edition 3, June 3, 2020

Printed in Malaysia



DAQ97-90000

www.keysight.com