



CHECKLINE®
MADE TO MEASURE

PRECISION QUALITY CONTROL INSTRUMENTS SINCE 1958

Features

Total Measuring Range *

0.025 - 36.000 in / 0.63 - 914.4mm

Measuring Range on Steel **

0.025 - 6.00 in / 0.60 - 150.0mm

- NIST-traceable Calibration Certificate
- Resolution of 0.001 inch (0.01 mm)
- Switch-selected units (inches or mm)
- 2-point calibration optimizes linearity over a wide measurement range
- Scan mode (100 readings/sec.) displays minimum thickness during the "scan"
- 5-step GAIN adjustment for optimal accuracy in challenging applications
- The extruded aluminum housing is impact-resistant and environmentally sealed (IP 65) for trouble-free use under tough field conditions
- For underwater surveying, a 50 ft (15 m) underwater probe/cable is optionally available
- LCD Display shows thickness value, velocity setting, gain setting, stability & battery indicators, scan mode, zero and units
- Two (2) AA Batteries provide 45 hours of continuous operation
- Selectable Backlight ON/OFF/AUTO
- 5 Year Warranty, CE-Certified and Made in USA

* Depends on material and transducer/probe type

** With standard T-102-2000 probe

TI-25MX Ultrasonic Wall Thickness Gauge

Measures thicknesses up to 36 in (915 mm) — from only one side

The Check-Line® TI-25MX Wall Thickness Gauge accurately measures wall thickness and the extent of corrosion of all metals, ceramics, glass and most rigid plastics—from only one side! It provides 8 preset materials (see below) plus 2 custom material velocities.

- | | |
|------------------|-----------------|
| 1. Steel 4340 | 6. PVC |
| 2. Stainless 303 | 7. Polystyrene |
| 3. Aluminum 2024 | 8. Polyurethane |
| 4. Cast Iron | 9. Custom1 |
| 5. Plexiglass | 10. Custom2 |

The user can adjust velocity as desired and calibrate to a sample of known thickness—the optimal acoustic velocity is automatically calculated. To optimize linearity over a wide range, the user can perform a two-point calibration to two samples of known thickness. The optimal velocity is calculated to provide the highest accuracy and linearity between the low and high calibration points. Calibration and setup parameters can be locked to prevent accidental adjustments.



Complete Kiti includes:

TI-25MX gauge, probe, 4 oz. bottle of coupling fluid, 2 AA batteries, NIST-traceable calibration certificate and operating instruction manual—all in a foam-fitted carrying case.





CHECKLINE®
MADE TO MEASURE

Checkline • 600 Oakland Ave, Cedarhurst NY 11516 - USA
www.Checkline.com • info@checkline.com • 516-295-4300

Specifications

Total Measuring Range (Steel)	0.025 – 36.000" (0.63 – 914.4mm) depends on material and transducer/probe type	Temp. Limits	<i>Ambient:</i> –22 to 167 °F (–30 to 75 °C) <i>Material:</i> 0 to 200 °F (–20 to 100 °C) High temperature probes available
Measuring Range (Steel)	0.040-6.000" (1.00 –150.0mm) with standard transducer T-102-2000	Battery Type	2x AA batteries (rechargeable batteries can be used)
Resolution	0.001" (0.01mm)	Battery Life	45 hours continuous use
Measuring Mode	Pulse-Echo (P-E)	Housing	Extruded aluminum body with nickel-plated aluminum end caps (gasket sealed)
Velocity Range	0.0120 to .7300 in/μs. 305 to 18,542 meters/sec	Housing Rating	IP65
GAIN Adjustment	Adjustable GAIN 5-position (VLOW, LOW, MED, HIGH, VH), in 3dB steps, 40-52dB	Keypad	Sealed membrane that is resistant to both water and petroleum products Seven or eight tactile-feedback keys
Probe (Standard)	1/4", 5 MHz Dual Element Transducer, actual wearface is 5/8" (17mm), p/n T-102-2000	Weight	11 oz. (308 grams)
Cable	4 ft. (1.2 m) waterproof cable with non-polarized, quick-disconnect connectors	Pulse Repetition Frequency (PRF)	200 Hz (200 pulses/sec)
Probes (optional)	1 to 10 MHz, 3/16" up to 1 inch (custom probes available)	Dimensions	2.5" x 5.17" x 1.25" (63.5 x 131.3 x 31.5mm)
Probe Wearface	PEEK (Polyethylethylkytone)	Accessories	Probe/cable assembly, 4 oz. bottle of coupling fluid, NIST Calibration Certificate, 2 AA batteries, operating instructions, hard-plastic carrying case.
LCD Display	Multi-function 7 segment 4.5 digit liquid crystal display with 0.500" digit height. Two 0.125 in14 segment fields for labels and values, and one 7 segment field for labels and values. Additional icons to indicate features and modes	Certifications	NIST Traceable and MIL-STD-45662A
Display Backlight	Backlight is selectable on/off/auto, and selectable brightness (Lo, Med, Hi)	Warranty	<i>Gauge:</i> 5 Years <i>Probes:</i> 90 Days
Display Update	10 Hz (10 updates/sec)		

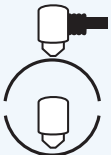
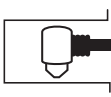
Measuring Limits

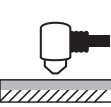
	Minimum Radius for Convex Surfaces	0.350" (8.89mm)
	Minimum Radius for Concave Surfaces	3" (76.2mm)
	Minimum Headroom	1" (25.0mm)
	Minimum Sample Diameter	0.150" (3.8mm)
	Minimum Substrate Thickness - F	na
	Minimum Substrate Thickness - NFe	na

Related Products

SB-Series Certified Steel Test Blocks	<ul style="list-style-type: none"> Precision Machined and Finished Includes Wooden Storage Box Includes NIST Traceable Calibration Certificate
TICC-M Protective Holder for Ultrasonic Gauges	<ul style="list-style-type: none"> Constructed from heavy-duty Cordura Nylon Built-in belt loop
V-Block Ultrasonic Transducer Holder	<ul style="list-style-type: none"> For 3/16" & 1/4" Transducers only
SB Step Block Steel Test Blocks without certification	<ul style="list-style-type: none"> Fabricated from 1018 Steel Supplied without certification
CF-12 Coupling Fluid	<ul style="list-style-type: none"> Temp Range: 0 - 200 °F, -18 - 93 °C
TI-25-UW-50 50 Ft. Underwater Probe / Cable Assembly	<ul style="list-style-type: none"> 50 Ft. Length, Waterproof Probe/Cable assembly with non-polarized, Dual-Lemo connectors.