



Advanced Test Equipment Rentals
www.atecorp.com 800-404-ATEC (2832)

HI-6100

Field Monitor

User Manual



HI-6100 Field Monitor shown with optional probes

ETS-Lindgren, Inc. reserves the right to make changes to any product described herein in order to improve function, design, or for any other reason. Nothing contained herein shall constitute ETS-Lindgren, Inc. assuming any liability whatsoever arising out of the application or use of any product or circuit described herein. ETS-Lindgren, Inc. does not convey any license under its patent rights or the rights of others.

© Copyright 2006–2012 by ETS-Lindgren, Inc. All Rights Reserved. No part of this document may be copied by any means without written permission from ETS-Lindgren, Inc.

Trademarks used in this document: The *ETS-Lindgren* logo is a trademark of ETS-Lindgren, Inc.

Revision Record | MANUAL,HI-6100 | Part #H-600099, Rev. F

Revision	Description	Date
A	Initial release	January, 2006
B	Add CE, update Set Up section	June, 2006
C	Revise to current style standards	June, 2008
D	Update outer dimensions, Physical Specifications section; Update System Menu and Find Probes sections	May, 2010
E	Updated back panel connectors	March, 2012
F	Updated field probe kits in <i>Optional Items</i> ; added information about laser safety interlock mechanism to <i>Introduction</i> .	December, 2012

Table of Contents

Table of Figures	vi
Notes, Cautions and Warnings.....	vii
General Safety Considerations	viii
1.0 Introduction	9
Standard Configuration	10
Optional Items	10
ETS-Lindgren Product Information Bulletin	11
2.0 Maintenance	13
Annual Calibration	13
Laser Probes and Maintenance of Fiber Optics.....	14
Cleaning Instructions	14
Handling Instructions	15
Upgrade Policies.....	15
Service Procedures	15
3.0 Specifications.....	17
Electrical Specifications	17
Physical Specifications	17
4.0 Assembly and Installation	19
Set Up Procedure	19
Battery Probe Set Up	19
Laser Probe Setup.....	20
Remote Connections	21
Mounting the HI-6100 in a Rack.....	21
Mounting Data Modules	22
5.0 Operation	25
Back Panel	25
Front Panel.....	26
HI-6100 Menu Options.....	26
Overview of HI-6100 Menu Options	27
HI-6100 Display	28
Previous Option	28
Find Probes Menu.....	29

Probe Menu	30
—Temperature Units.....	30
—MinMax Reset	31
—Range	32
—Axis Enable	32
Display Menu.....	33
—Channel Enable.....	33
—Probe Parameter	35
—Lower Display.....	36
—Color	37
Remote Menu	38
—GPIB Address.....	38
—RS-232 Baud.....	39
System Menu.....	40
—Set Time.....	40
—Reset.....	41
—More	41
—Software	42
—Mode	43
—Update Software.....	44
—GPIB Output Mode	45
GPIB Status Menu	46
6.0 Remote Operation.....	47
IEEE-488 Requirements	47
Command Set Format.....	47
IEEE-488 (GPIB) Communications	48
RS-232 Communications	48
RS-232 Settings.....	48
Remote Commands.....	50
—Read Probe	50

—Read Battery Voltages.....	51
—Read Peak	51
—Reset Peak.....	51
—Read Temperatures.....	52
—Setup Recall.....	52
—Setup Save.....	53
—Software Revision.....	53
—Verbose Mode.....	54
—Last Errors.....	54
—Channel Enable.....	55
—Local Mode.....	55
7.0 Error Handling and Troubleshooting.....	57
Error Handling	57
Troubleshooting.....	57
Appendix A: Warranty	59
Appendix B: EC Declaration of Conformity	61
Appendix C: Commands	63
IEEE 488.2 Commands	63
Standard Commands.....	63
Appendix D: Commands in FM5004 Mode	65
Unsupported Commands in FM5004 Mode.....	65
Alarm Functions.....	65
Analog Output Functions.....	66
Other Commands.....	66
FM5004 Commands	67
IEEE 488.2 Commands.....	67
Supported Commands	68
Unsupported Commands	69
Appendix E: GPIB Register.....	71

Table of Figures

Figure 1: HI-6100 Field Monitor	9
Figure 2: HI-6100 Module Locations	22
Figure 3: Optical Data Module	22
Figure 4: Laser Data Module	23
Figure 5: HI-6100 Back Panel	25
Figure 6: HI-6100 Front Panel (shown with optional case)	26
Figure 7: Overview of HI-6100 Menu Options	27
Figure 8: Previous Option On Each Menu	28
Figure 9: Find Probes Menu	29
Figure 10: Probe Menu	30
Figure 11: Probe Menu—Temperature Units Selection.....	30
Figure 12: Probe Menu—Min/Max Reset	31
Figure 13: Probe Menu—Range	32
Figure 14: Probe Menu—Axis Enable.....	32
Figure 15: Display Menu	33
Figure 16: Display Menu—Channel Enable	33
Figure 17: Channel Enable Selected—Three Channel Displays.....	34
Figure 18: Display Menu—Probe Parameter.....	35
Figure 19: Display Menu—Lower Display	36
Figure 20: Display Menu—Color	37
Figure 21: Remote Menu	38
Figure 22: Remote Menu—GPIB Address	38
Figure 23: Remote Menu—RS-232 Baud.....	39
Figure 24: System Menu.....	40
Figure 25: System Menu—Set Time	40
Figure 26: System Menu—Reset.....	41
Figure 27: System Menu—More	41
Figure 28: System, More Menu—Software	42
Figure 29: System, More Menu—Mode	43
Figure 30: System, More Menu—Update Software	44
Figure 31: System, More Menu—GPIB Output Mode.....	45
Figure 32: GPIB Status	46
Figure 33: System, GPIB Status Menu—Remote/Local.....	46
Figure 34: RS-232 Communication Settings Table	48
Figure 35: HI-6100 Pin # Designations Table	49
Figure 36: GPIB Registers	71



Notes, Cautions and Warnings

	<p>Note: Denotes helpful information intended to provide tips for better use of the product.</p>
<p>CAUTION</p>	<p>Caution: Denotes a hazard. Failure to follow instructions could result in minor personal injury and/or property damage. Included text gives proper procedures.</p>
<p>WARNING</p>	<p>Warning: Denotes a hazard. Failure to follow instructions could result in SEVERE personal injury and/or property damage. Included text gives proper procedures.</p>

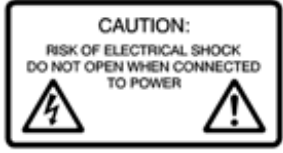

See the ETS-Lindgren *Product Information Bulletin* for safety, regulatory, and other product marking information.

General Safety Considerations

 <p>CAUTION: RISK OF ELECTRICAL SHOCK DO NOT OPEN WHEN CONNECTED TO POWER</p>	<p>Caution: Uninsulated voltage within the unit may have sufficient magnitude to cause electric shock. Therefore, it is dangerous to make any kind of contact with any parts inside this unit.</p>
	<p>Warning: This is a Safety Class I product (provided with a protective earthing ground incorporated in the power cord). The mains plug shall only be inserted in a socket outlet provided with a protective earth contact. Any interruption of the protective conductor, inside or outside the instrument, is likely to make the instrument dangerous. Intentional interruption is prohibited. DO NOT defeat the earth grounding protection by using an extension cable, power cable, or autotransformer without a protective ground conductor.</p>



See the ETS-Lindgren *Product Information Bulletin* for safety, regulatory, and other product marking information.

1.0 Introduction

The **ETS-Lindgren HI-6100 Field Monitor** is a broadband electric and magnetic field probe monitor designed for use in radio frequency interference/electromagnetic compatibility (RFI/EMC) test system applications. It accepts inputs from up to four isotropic field probes and analyzes and displays that information on a user-configurable LCD display. It also provides two digital interfaces: IEEE-488 and RS-232.



Figure 1: HI-6100 Field Monitor

The HI-6100 is compatible with ETS-Lindgren electric (E) field or magnetic (H) field probes or laser probes. It has a probe-dependent frequency response of 10 kHz to 40 GHz and a probe-dependent sensitivity of 0.5 V/m to 3000 V/m, 15.0 mA/m to 30 A/m.

The HI-6100 incorporates a safety interlock mechanism that turns off the laser if it does not receive data from the probe within a specified time frame. The safety mechanism is intended to prevent injury from the laser if the HI-6100 issues a command to turn on the laser while the fiber optic cables are disconnected, improperly connected, cut, or damaged.

The HI-6100 in native HI-6100 mode is the preferred method for use with the laser-powered field probes as well as the HI-60XX Series battery-powered field probes.

The HI-6100 in FM5004-compatible mode is primarily used with the HI-44XX Series probes for backward portability.

Standard Configuration



ETS-Lindgren may substitute a similar part or new part number with the same functionality for another part/part number. Contact ETS-Lindgren for questions about part numbers and ordering parts.

Part Description	Part Number
HI-6100 Field Monitor	HI-6100
Shipping End Caps	H-390076
Power Cord	Contact ETS-Lindgren Customer Service for power cord part number for your configuration

Optional Items



ETS-Lindgren may substitute a similar part or new part number with the same functionality for another part/part number. Contact ETS-Lindgren for questions about part numbers and ordering parts.

Part Description	Part Number
Bench Top Case	H-491271
Laser Pro Kits	HI-6105FM HI-6153FM HI-6122FM
Field Probe Kits	HI-6053FM HI-6022FM HI-6005FM
Probe Stand	H-491269
SMA Feedthrough	H-231205000
FC Feedthrough	H-23861521000
ST Feedthrough	708027

Part Description	Part Number
Fiber Optic Cable (SMA)	H-491106-XX
Fiber Optic Cable (FC/ST)	H-491263-XX
Cleaning Kit	H-34F01

ETS-Lindgren Product Information Bulletin

See the ETS-Lindgren *Product Information Bulletin* included with your shipment for the following:

- Warranty information
- Safety, regulatory, and other product marking information
- Steps to receive your shipment
- Steps to return a component for service
- ETS-Lindgren calibration service
- ETS-Lindgren contact information

This page intentionally left blank.

2.0 Maintenance

CAUTION

Before performing any maintenance, follow the safety information in the ETS-Lindgren *Product Information Bulletin* included with your shipment.



Maintenance of the HI-6100 is limited to external components such as cables or connectors.

Clean the exterior of the cabinet using a damp cloth and mild cleaner. Always unplug the unit before cleaning.

To prevent electrical shock, do not remove cover.

Warranty may be void if the housing is opened.

Any task that requires disassembly of the HI-6100 should be performed at the factory.

If you have any questions concerning maintenance, contact ETS-Lindgren Customer Service.

Annual Calibration

Probes used with the HI-6100 Field Monitor require annual calibration to verify that they are performing within specifications. See the *Product Information Bulletin* included with your shipment for information on ETS-Lindgren calibration services.

Laser Probes and Maintenance of Fiber Optics

The fiber optic connectors and cables used with laser-powered probes can be damaged from airborne particles, humidity and moisture, oils from the human body, and debris from the connectors they plug into. Always handle connectors and cables with care, using the following guidelines.



Before performing any maintenance, disconnect the fiber optic cables from the unit and turn off power.

When disconnecting fiber optic cables, apply the included dust caps to the ends to maintain their integrity.

Before connecting fiber optic cables, clean the connector tips and in-line connectors.

Before attaching in-line connectors, clean them with moisture-free compressed air.

Failure to perform these tasks may result in damage to the fiber optic connectors or cables.

CLEANING INSTRUCTIONS



See an online demonstration of the proper cleaning procedure at www.ets-lindgren.com/FiberCleaning.

- When handling fiber optic cables and connectors it is important that the mating connectors, fiber tip, and ferrule be cleaned before inserted into the fiber optic system.
- To clean the sides of the ferrule, use a folded lens-grade, lint-free tissue saturated in industrial grade isopropyl alcohol. Place the connector ferrule in the folded tissue, and apply pressure to the sides of the ferrule. Rotate the ferrule several times to remove all contamination from the ferrule sides.

- Use the cleaning tape shipped with the HI-6105 kit for cleaning the end face of the connector. Softly press the connector face on the exposed cleaning tape and move in a figure eight motion. After three figure eights inspect with a microscope and repeat if necessary.
- The mating connectors such as bulkhead feedthrough, transmit, and receive ports can be cleaned with canned dry air. Fiber optic connectors should be cleaned every time they are mated and unmated.

HANDLING INSTRUCTIONS

CAUTION

Never touch the end face of the connector.

Connectors not in use should be covered over the ferrule by a plastic dust cap or boot. These boots will protect the polished ferrule end from damage but not contamination. It is important to note that inside the dust cap there is a sticky residue that is a by-product of making the dust cap. This residue will remain on the ferrule end after the cap is removed. Always clean fiber connectors and mating connectors prior to installation.

Upgrade Policies

System upgrades are made periodically to enhance functionality. Contact ETS-Lindgren Customer Service or see www.ets-lindgren.com to determine the upgrade status of your measurement system.

Service Procedures

For the steps to return a system or system component to ETS-Lindgren for service, see the *Product Information Bulletin* included with your shipment.

This page intentionally left blank.

3.0 Specifications

Electrical Specifications

Nominal AC Voltage:	115/230 V
Input Frequency:	50/60 Hz
Maximum Output Power:	250 W

Physical Specifications

Outer Dimensions:	Length: 48.3 cm (19 in) Width: 35.6 cm (14 in) Height: 13.3 cm (5.25 in)
Approximate Weight:	5.9 kg (13 lb)
Approximate Weight, including Optional Bench Top Case:	11.8 kg (26 lb)

This page intentionally left blank.

4.0 Assembly and Installation

CAUTION

Before connecting or operating any components, follow the safety information in the ETS-Lindgren *Product Information Bulletin* included with your shipment.

CAUTION

Prior to assembly and installation, see *Cleaning Instructions* on page 14 and *Handling Instructions* on page 15.

Set Up Procedure

Perform the following procedures to verify system operation before installation in the test environment.

BATTERY PROBE SET UP

1. Make sure the battery powered probes are fully charged. See the probes manual for charging information. If laser probes are to be used, read the probes manual to become familiar with the operation. See *Laser Probe Setup* on page 20 for detailed information.
2. Remove the plastic caps from the appropriate RF SENSOR I/O connectors on the back panel of the receiver. Remove the protective covers from the fiber optic cable assembly. Save all protective caps and covers for future use.
3. Visually inspect and clean the tips of the fiber optic cables to verify they are free from dirt or other contaminants. Connect the fiber optic cable to the RF SENSOR I/O connector pair, matching the cable connector colors to those on the receiver connectors (yellow to XMIT, white to RCV).
4. Connect the other end of the fiber optic cable to the sensor connectors: white to XMIT, yellow to RCV.



The fiber connectors on the HI-60XX Series probes are permanently attached.

5. Connect the AC power cord to the IEC connector on the back of the HI-6100 Field Monitor. Verify the power supply switch is in the ON position.
6. Plug the other end of the power cord into an electrical outlet.
7. Turn on the battery powered probe(s).
8. Turn on the power switch on the front panel. It may take several seconds for the display to appear.
9. To display the probes attached, press the *Find All Probes* key on the main menu of the display screen to see information for all of the probes.

LASER PROBE SETUP

1. Remove the plastic dust caps from the appropriate DEVICE INTERFACE CHANNEL located on the back of the HI-6100. Save all protective caps and covers for future use. Clean transmit and receive ports using canned dry air.
2. Remove the dust caps from the probe and follow the instructions on page 14 to clean the fiber connectors. If extension cables and bulkhead feedthrough connectors will be used, clean as described. Connect the fiber optic cable to the selected DEVICE INTERFACE CHANNEL. Both the FC and the ST connectors are keyed.
3. Connect the AC power cord to the IEC connector on the back of the HI-6100. Verify the power supply switch is in the ON position.
4. Plug the other end of the power cord into an electrical outlet.
5. Turn on the power switch on the front panel. It may take several seconds for the display to appear.
6. To display the probes attached, press the *Find All Probes* key on the main menu of the display screen to see information for all of the probes.

Remote Connections

For remote-controlled operation of the HI-6100 connect the RS-232 or IEEE-488 cable to the appropriate connector.

- If RS-232 remote control is used, see *Remote Operation* on page 47 for information on setting the device baud rate.
- If IEEE-488 remote control is used, set the DEVICE ADDRESS to the appropriate bus address for your installation. See *Operation* on page 25 for information on setting the device address.

Test remote operation by issuing an *IDN? command from the remote controller (*IDN?<LF>) and verify that the HI-6100 returns the proper response. See *Remote Operation* on page 47 for additional information.

Mounting the HI-6100 in a Rack

This product is designed for use in Installation Category II and Pollution Degree II per IEC-1010 and IEC-664. When installing the HI-6100 in a rack the convection into and out of the product must not be restricted. The ambient temperature (outside of the rack) must be less than the maximum operating temperature of the HI-6100 by 4°C for every 100 Watts dissipated in the rack. If the total power dissipated in the cabinet is greater than 800 Watts, then forced convection must be used.

Mounting Data Modules

Optical data modules or laser data modules may be mounted on any available channel.

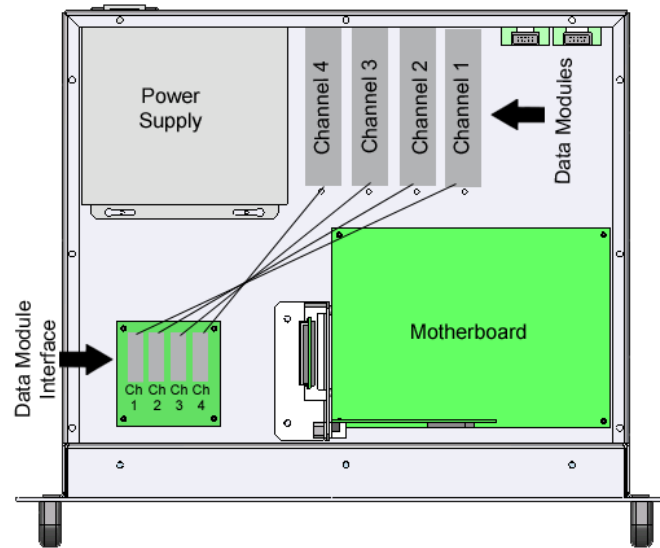

Figure 2: HI-6100 Module Locations

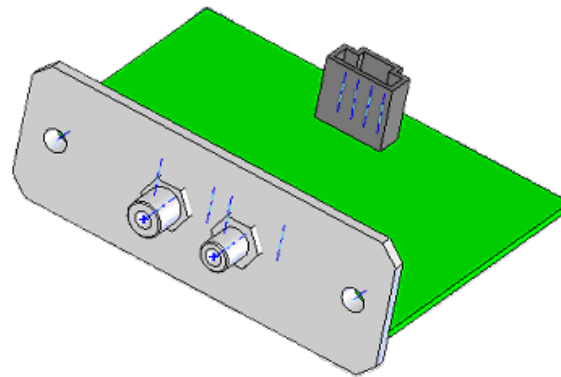

Figure 3: Optical Data Module

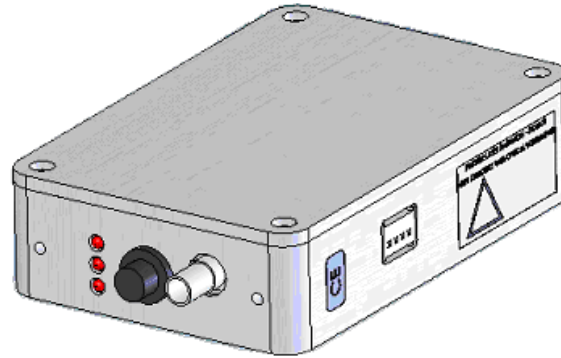

Figure 4: Laser Data Module

1. Remove the cover by removing the two screws on the back panel and the nut on the laser data module angle bracket, if installed.
2. Place the new module in the desired channel location and secure with two screws on the back panel and the nut on a laser data module angle bracket, if available.
3. Attach one end of the data module cable to the data module and the other end to the corresponding channel and data module interface board.

This page intentionally left blank.

5.0 Operation

CAUTION

This instrument is shipped with a three-wire power cable, in accordance with international safety standards. When connected to an appropriate power line outlet, this cable grounds the instrument cabinet.

Back Panel

WARNING

Do not block the power supply fan. It must remain unobstructed at all times.

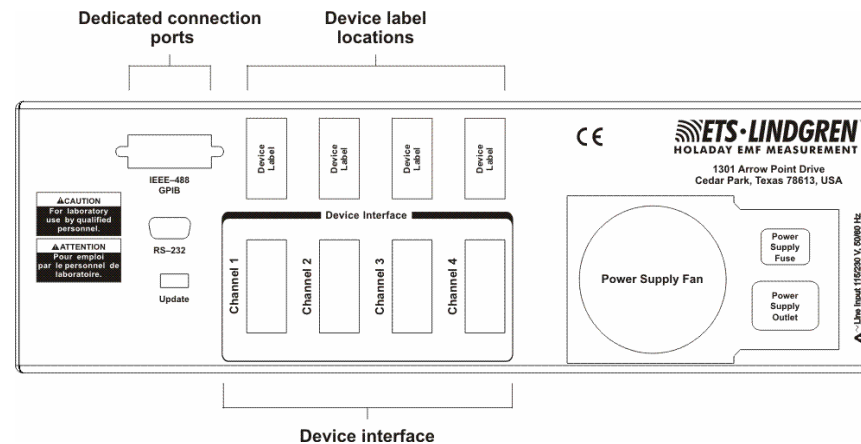

Figure 5: HI-6100 Back Panel

The back panel of the HI-6100 Field Monitor includes:

- **Dedicated connection ports**—IEEE-488 GPIB, RS-232, and Update.
- **Device label locations**—Place the warning label shipped with each probe in these marked locations.
- **Device Interface**—Four interface slots (Channel 1, Channel 2, Channel 3, Channel 4) to accommodate up to four probes.

Front Panel

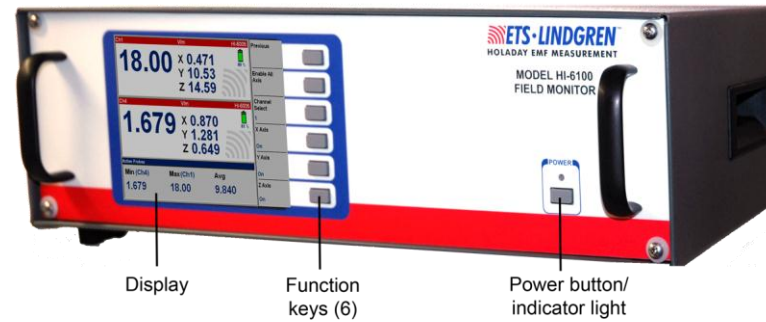

Figure 6: HI-6100 Front Panel (shown with optional case)

The front panel of the HI-6100 includes:

- **Display**—Enables the user to see the active probe(s).
- **Function keys (6)**—Allow the user to easily navigate the menus of the controller.
- **Power button**—Includes an indicator light allowing the user to easily verify if the unit is on or off.



To turn off the HI-6100, press and hold the power button for three to four seconds.

HI-6100 Menu Options

On the page 27 is an illustration of the HI-6100 menu hierarchy. The illustration serves as an overview or map of the menu options; the remainder of this chapter describes each option.

Overview of HI-6100 Menu Options

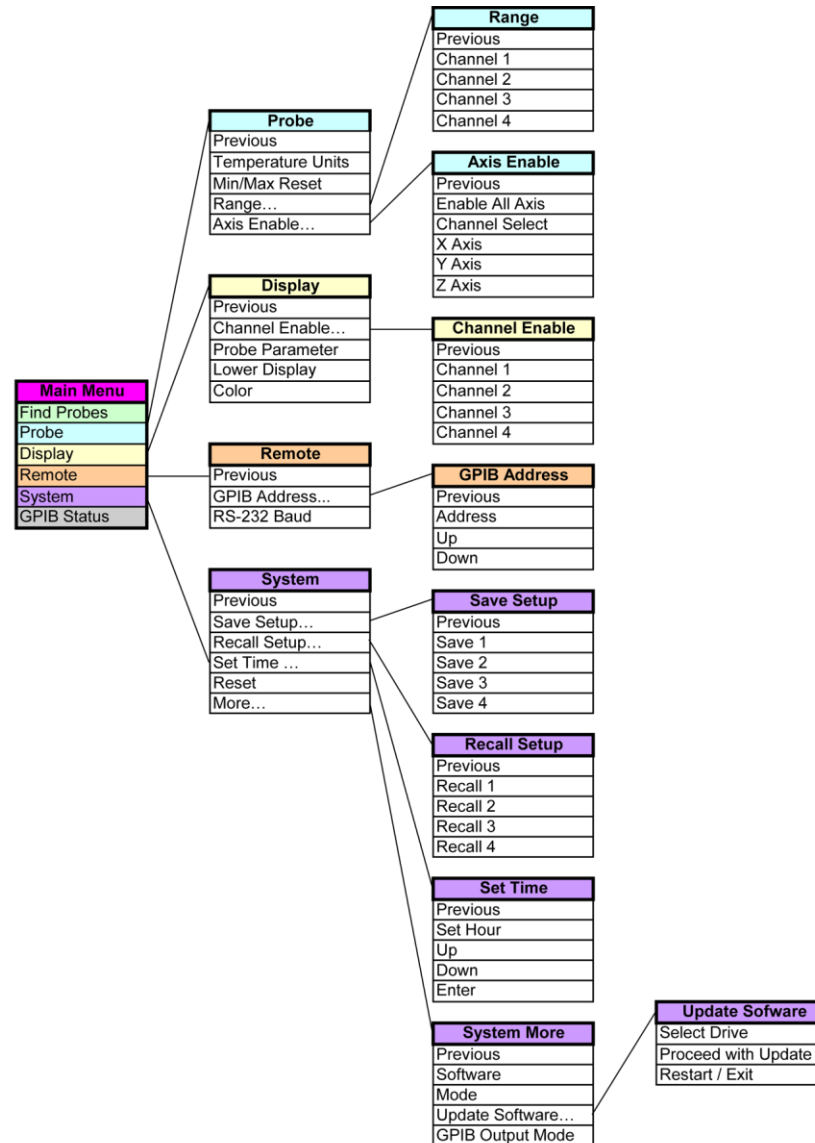

Figure 7: Overview of HI-6100 Menu Options

HI-6100 Display

PREVIOUS OPTION



Select **Previous** at the top of each menu series to return to the previous screen and, eventually, to the main menu.



Figure 8: Previous Option On Each Menu

FIND PROBES MENU

The HI-6100 display simultaneously exhibits up to four probes. Select **Find Probes** to automatically display the number of probes that are enabled. The system will search each channel, determine which of the enabled channels are active, and then display those channels.

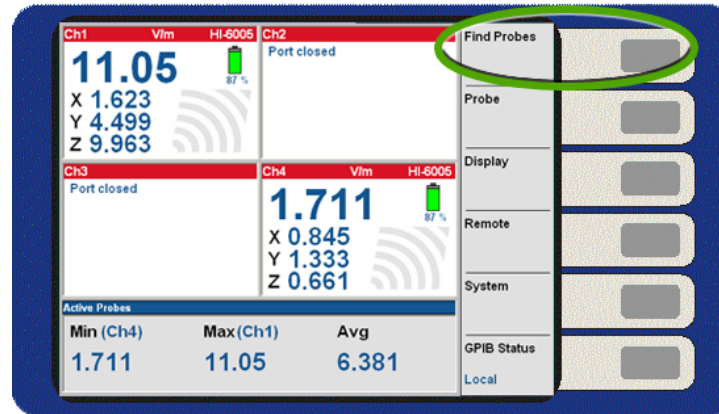

Figure 9: Find Probes Menu



To enable a channel, see the *Display Menu* on page 33. When selections are made in the menu they are immediately saved. Only enabled channels will be detected by selecting **Find Probes**.



To maximize the system performance, only enable the channels that contain active probes.

PROBE MENU

Selecting **Probe** provides several choices that relate directly to the information available for the probe(s) in use.

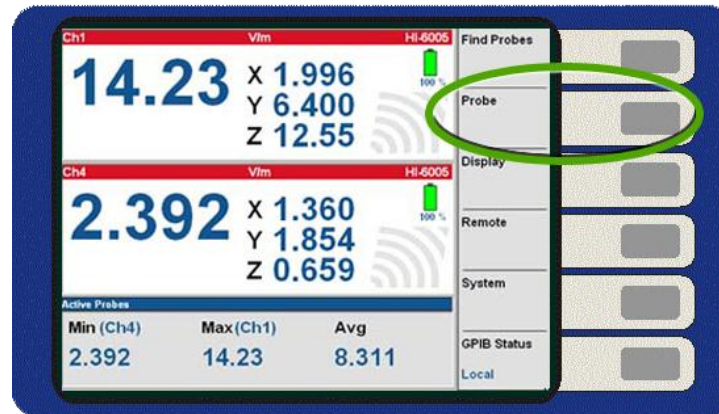

Figure 10: Probe Menu

—Temperature Units

Select **Temperature Units** to toggle between Fahrenheit and Celsius temperature readings.

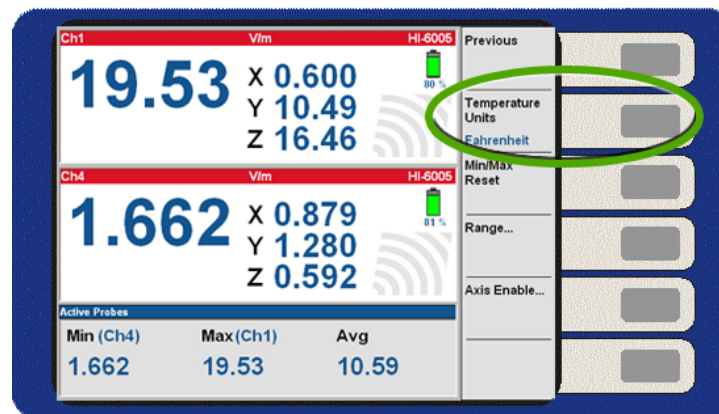

Figure 11: Probe Menu—Temperature Units Selection

—MinMax Reset

Select **Min/Max Reset** to reset the individual probe values. Please note that the min/max values may not be visible.

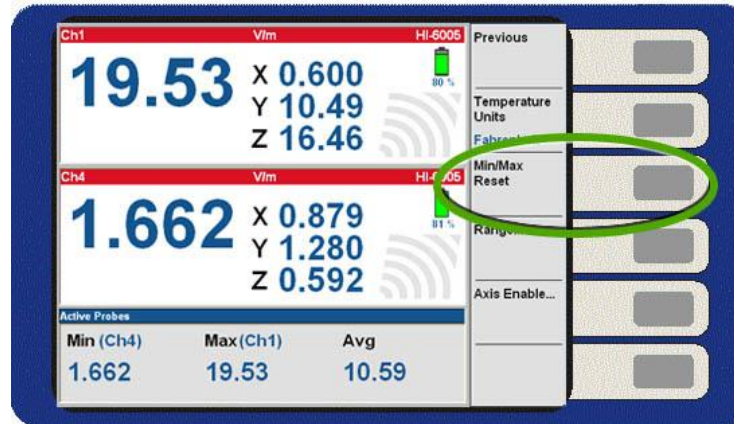

Figure 12: Probe Menu—Min/Max Reset



The **Range** and **Axis Enable** options under the **Probe** menu will only appear when the mode is set to **FM5004** under the **Systems** menu.

—Range

Select **Range** to manually set the range. The HI-6XXX probe range is not adjustable; these are single range probes.

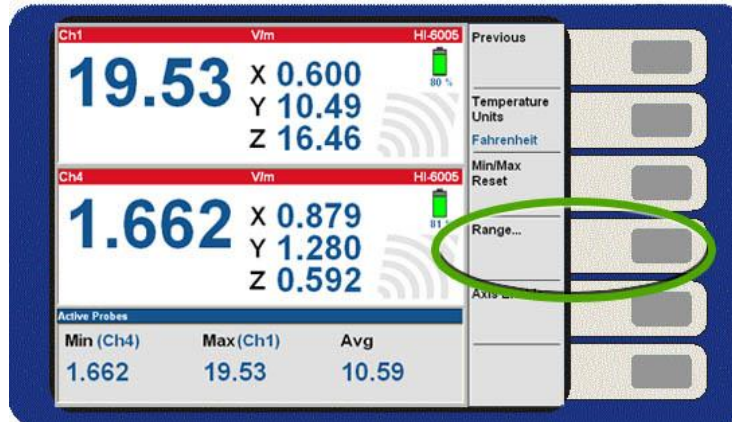

Figure 13: Probe Menu—Range

—Axis Enable

Use **Axis Enable** to select the channel or probe to be adjusted and the axis to be enabled or disabled.

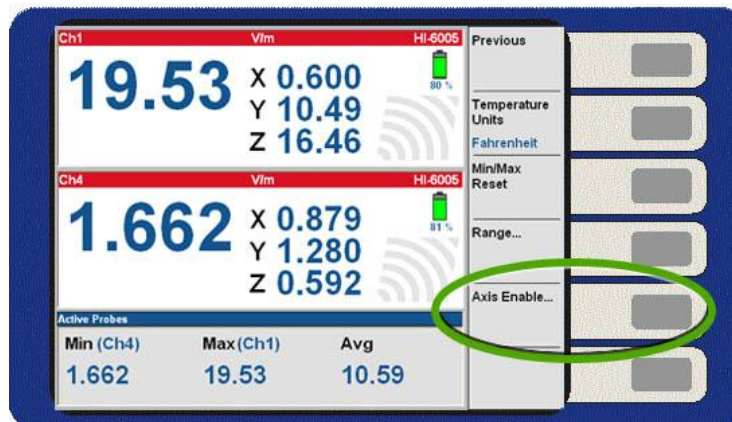

Figure 14: Probe Menu—Axis Enable

DISPLAY MENU

Select **Display** from the main menu to customize the display.



Figure 15: Display Menu

—Channel Enable

Choose **Channel Enable** from the display menu to manually select the channel(s) to view on the display. Up to four channels may be viewed on one screen.

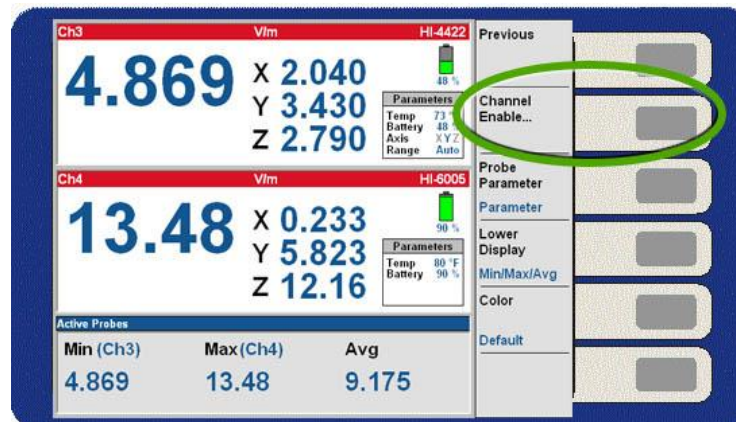

Figure 16: Display Menu—Channel Enable

Once **Channel Enable** is selected, the user may distinguish which channels are currently on/off by selecting the screen where each channel and their status are noted. In addition, the user has the option to turn on/off a channel by pressing that channel button.



To maximize the system performance, only enable the channels that contain active probes.



Figure 17: Channel Enable Selected—Three Channel Displays

—Probe Parameter

When selecting **Probe Parameter**, the lower right corner of the active channel screen(s) will toggle between parameters, min/max/avg, and laser warning views. When the program is closed, upon re-starting the system the display automatically appear as it was last configured.

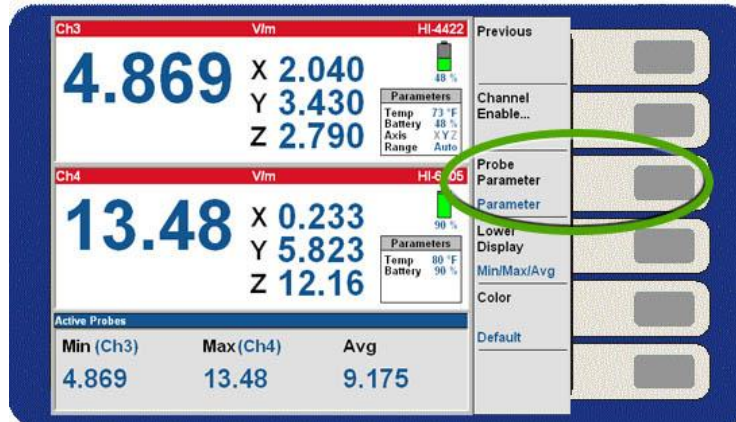

Figure 18: Display Menu—Probe Parameter

—Lower Display

Lower Display corresponds to the window shaded gray at the bottom of the display. By pressing the button for this option, the system will toggle between the probe, min/max/avg for all active probes, controller error, and probe error information. When the controller and probe error readouts are selected, the last six errors the system experienced will be visible.



Figure 19: Display Menu—Lower Display

—Color

Select **Color** to scroll through several pre-determined color schemes. These color schemes are designed to allow optimal display of the monitor information accommodating unique user environments.

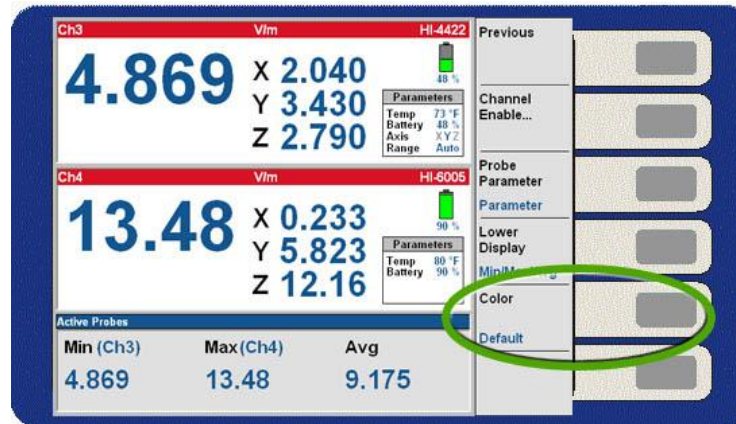

Figure 20: Display Menu—Color

REMOTE MENU

Select **Remote** to set the communication parameters.



Figure 21: Remote Menu

—GPIB Address

By selecting **GPIB Address** in the **Remote** menu, the address will scroll between 31 available addresses.



Figure 22: Remote Menu—GPIB Address

—RS-232 Baud

Select **RS-232 Baud** to set the baud rate for the external serial ports.

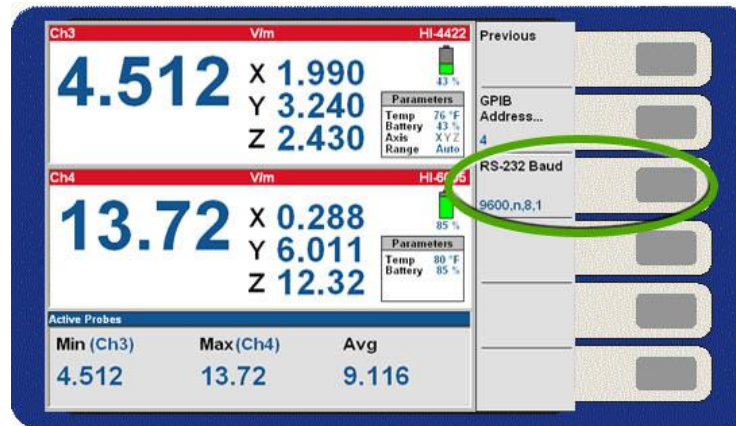

Figure 23: Remote Menu—RS-232 Baud

SYSTEM MENU

Select **System** to access systems settings.



Figure 24: System Menu

—Set Time

Select **Set Time** to set the time.



Figure 25: System Menu—Set Time

—Reset

Select **Reset** to return the HI-6100 to the factory default configuration.



Figure 26: System Menu—Reset

—More

Select **More** to display a list of additional system selections.



Figure 27: System Menu—More

—Software

For informational purposes only. The button has no effect.



Figure 28: System, More Menu—Software

—Mode

Allows the HI-6100 to operate as an FM5004 field monitor.

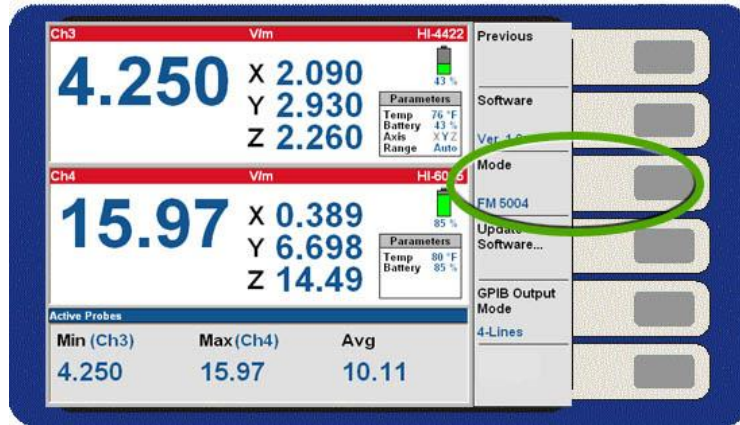

Figure 29: System, More Menu—Mode

In this mode the HI-6100 will communicate with the FP2000, FP5000, HI-6000, and HI-4400 series of probes. See Appendix D on page 65 for a list of supported FM5004 commands.

In the HI-6100 mode only the HI-6000 series probes are supported and a new GPIB command set is utilized. See Appendix C on page 63 for HI-6100 commands.

—Update Software

Allows the user to upgrade the software.



Figure 30: System, More Menu—Update Software

To download and install upgrades for the HI-6100 operating system:

- Go to www.ets-lindgren.com.
- On the **Resources** menu, click **Software/Firmware**.
- Find the HI-6100 upgrade file in the **Software** column and follow the on-screen instructions to download.
- Follow the instructions included with the file to install the updated software.



Any changes made to the system setup are automatically saved.

—GPIB Output Mode

Allows the user to configure the HI-6100 to format the output data while in FM5004 mode. The **4-Lines** setting requires four consecutive reads (ibrd). The **1-Line** setting requires a single read. This setting has no effect when the HI-6100 mode is selected.



Figure 31: System, More Menu—GPIB Output Mode

GPIB STATUS MENU

GPIB Status allows the user to return the HI-6100 to local mode. This enables all other menu functions.



Figure 32: GPIB Status

Select **Remote/Local** to toggle between the two selections.

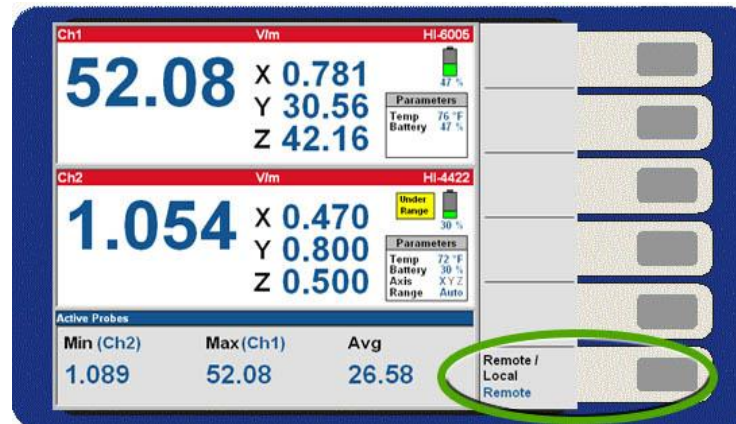

Figure 33: System, GPIB Status Menu—Remote/Local

6.0 Remote Operation

CAUTION

Before connecting or operating any components, follow the safety information in the ETS-Lindgren *Product Information Bulletin* included with your shipment.

This chapter describes remote operation of the HI-6100 Field Monitor using either the IEEE-488 parallel port or the RS-232 serial port connected to a remote device, such as an IEEE-488 bus or a personal computer.

IEEE-488 Requirements

For IEEE-488 operation, the device address is set to 4 at the factory.

Command Set Format

Each command or query code is composed of four alpha characters and optional numerical parameters. When a query is received, the receiver returns a string consisting of the query followed by the current setup for that command. Commands can be entered in upper or lower case.

A line feed, <LF>, terminates all commands. To include several commands in a single command string, separate each command by a semicolon (delimiter). Do not include spaces between a command and its associated numeric parameter. Data returned from the receiver will be terminated with a <CR><LF>.

IEEE-488 (GPIB) Communications

For General Purpose Interface Bus (GPIB) communications, the End or Identify (EOI) control line may also be used for command termination. Terminate the command with <LF>, EOI, or both when sending commands to the receiver via the GPIB. No characters are permitted after <LF> or EOI; the system interprets characters following <LF> or EOI as the start of another command.

When an error condition is present at the receiver, the service request (SRQ) signal is asserted. The operator can then perform a serial poll operation. The receiver error code (in binary) is contained in the lower bits of the serial poll status byte. If the receiver is addressed as a listener and the GPIB remote line is asserted, the receiver will switch to remote mode.

RS-232 Communications

Commands are processed in a manner very similar to that of the IEEE interface. The command structure is identical, except that an EOI line does not exist; therefore, <LF> must terminate all commands. When a valid command is received, it is processed and the result is immediately transmitted back over the RS-232 interface. The output format is identical to that of the IEEE format except, again, an EOI line does not exist.

RS-232 Settings

Word Length	8 bits
Stop Bits	1
Baud Rate	1200 – 115,200 (menu selectable)
Parity	None

Figure 34: RS-232 Communication Settings Table



→ Signifies output from the HI-6100

← Signifies input to the HI-6100

HI-6100 Pin #	Signal	Data Direction	Description
1	DCD	←	Device Carrier Detect
2	RD	←	Receive Data
3	TD	→	Transmit Data
4	DTR	→	Data Terminal Ready
5	GND	N/A	Ground
6	NC	N/A	No Connection
7	RTS	←	Ready to Send
8	CTS	→	Clear to Send
9	NC	N/A	No Connection

Figure 35: HI-6100 Pin # Designations Table



A null modem cable or adapter (supplied by the user) is required for interfacing the HI-6100 to a standard serial port on a computer.

Remote Commands

The commands described in the following pages are available to the user for remote communications with the HI-6100. The following conventions are used:

1. A lower case *x* in the command or returned data syntax represents a numeric value.
2. A lower case *n* in the command or returned data syntax represents a channel number (1 through 4) associated with a system probe.
3. A lower case *m* in the command or returned data syntax represents a mode selection.

—Read Probe

Writes the current probe field values to a remote port.

Syntax: RPRB,x

Parameters: (x)

0 = Reads all channels

1 = Reads channel 1

2 = Reads channel 2

3 = Reads channel 3

4 = Reads channel 4

5 = Reads minimum, maximum and average of all active probes

Output format: xx.xxuuuuuuoca,xx.xxuuuuuuoca,,<CR><LF>

Each axis or channel data block consists of a fourteen-character string. The first comma-separated data block is the sum of all axis followed by X, Y, and then Z axis.

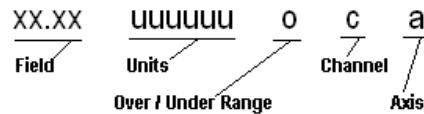

The over/under range character will be blank, U or O. The axis character will be c,x,y,z or blank.

—Read Battery Voltages

Returns the current battery percentages of probes in use.

Syntax: RBAT?

Parameters: None

To check the current battery percent of the probes in use: RBAT?<LF>

Response: 62%,100%,,<CR><LF>



Channels 3 and 4 are not on or not ready.

—Read Peak

Writes the peak probe field values to a remote port.

Syntax: RDPK,x

Parameters: (x)

1 = Reads channel 1 max

5 = Reads channel 1 min

2 = Reads channel 2 max

6 = Reads channel 2 min

3 = Reads channel 3 max

7 = Reads channel 3 min

4 = Reads channel 4 max

8 = Reads channel 4 min

Output format: Ch1 Max xx.xx,Xxx.xx,Yxx.xx,Zxx.xx<CR><LF>

—Reset Peak

Resets peak probe field values.

Syntax: RSPK

Parameters: None

—Read Temperatures

Returns the current temperature reading from the probes in use.

Syntax: RTMP?

Parameters: None

To check the current temperature of the probes in use: RTMP?<LF>

Response: 77F,100F,,<CR><LF>



Channels 3 and 4 are not on or not ready.

—Setup Recall

Recalls a saved HI-6100 setup.

Syntax: RECL,x

Parameters: (x)

1 = Recall setup #1

3 = Recall setup #3

2 = Recall setup #2

4 = Recall setup #4

To recall setup #1 and change to the setup configuration #1: RECL,1<LF>

—Setup Save

Saves the HI-6100 current configuration into memory.

Syntax: SAVE,x

Parameters: (x)

1 = Saves to setup #1

3 = Saves to setup #3

2 = Saves to setup #2

4 = Saves to setup #4

To save the current configuration to setup #1: SAVE,1<LF>

The setup will be saved to memory and can be recalled with the command RECL,1.

—Software Revision

Returns the current revision of the HI-6100 operating software.

Syntax: SREV

Parameters: None

To check the current revision of the HI-6100 software: SREV?<LF>

Response: SREV,1.0<CR><LF>

—Verbose Mode

Sets the HI-6100 to respond to all remote commands or to respond to inquiries only.

Syntax: VERB,x

Parameters: (x)

0 = Verbose mode disabled

1 = Verbose mode on

Examples

- To enter verbose mode:

VERB,1<LF>

Response: -VERB,1<CR><LF>

- To disable verbose mode:

VERB,0<LF>

Response: The HI-6100 will not respond (verbose mode off).

—Last Errors

Syntax: LERR?

Parameters: None

To see the last errors: LERR?<LF>

Response

- The HI-6100 will respond with the same information as displayed in the GPIB and probe list box errors.
- If no errors are logged, the HI-6100 will respond with:
NO errors logged.<CR><LF>

—Channel Enable

Used to set a channel on or off.



This command should not be used to toggle a channel on and off frequently. Probes may require several seconds to reinitialize.

Syntax: CHAN,m,n

Parameters: Channel number (m) on/off (n):

1 = Channel 1

3 = Channel 3

2 = Channel 2

4 = Channel 4

To enable channel 1: CHAN,1,1<LF>

—Local Mode

Returns the HI-6100 to local mode when it is in remote mode. Local mode allows the operator to use the front panel buttons.

Syntax: LOCL,x

Parameters: Local mode enable (x)

0 = Local mode disabled

1 = Local mode enabled

To return the HI-6100 to local mode (front panel buttons become operational): LOCL,1<LF>

This page intentionally left blank.

7.0 Error Handling and Troubleshooting

Error Handling

The user interface display contains two error list boxes. These error list boxes may be displayed from the **DISPLAY** menu by selecting **LOWER DISPLAY**. If any errors have occurred since the system was powered on, each box will display up to the last six error messages.

Troubleshooting

Following are some common troubleshooting tips for the HI-6100 Field Monitor. If you have a problem not listed or if the corrective action fails, contact ETS-Lindgren Customer Service.

Indication	Possible Cause / Corrective Action
Probe fails to communicate with HI-6100	<ul style="list-style-type: none">• Fiber optic cable reversed: Confirm cable is connected properly• Dirty fiber optic cable ends: Clean to remove dirt or contaminants• Bad cable or faulty connector: Replace cable• Dead battery: Charge battery
HI-6100 fails to power up	<ul style="list-style-type: none">• Power cord unplugged or faulty: Confirm cable is connected properly. To replace cord, contact Customer Service.

This page intentionally left blank.

Appendix A: Warranty



See the *Product Information Bulletin* included with your shipment for the complete ETS-Lindgren warranty for your HI-6100.

DURATION OF WARRANTIES FOR THE HI-6100

All product warranties, except the warranty of title, and all remedies for warranty failures are limited to three years.

Product Warranted	Duration of Warranty Period
HI-6100 Field Monitor	3 Years

This page intentionally left blank.

Appendix B: EC Declaration of Conformity



European Community Declaration of Conformity (in accordance with EN 45014:1998)

We, ETS-Lindgren, L.P., 1301 Arrow Point Drive, Cedar Park, TX, 78613, USA, declare that:

Model HI-6100 Field Monitor

to which this declaration relates, meets the requirements and conforms with the EC Directives listed below using the relevant section of the following EC standards and other normative documents;

Directive(s):

EEC/73/23	The Low Voltage Directive (and its amending directives)
EEC/89/336	The Electromagnetic Compatibility Directive (and its amending directives)
EN61326-1	Conducted Emissions, Class A Radiated Emissions, Class A
EN61010-1	Safety requirements for electrical equipment for measurement, control, and laboratory use

Standard(s):

EN61000-3-2	Power Line Harmonics
EN61000-3-3	Flicker of AC power loads

I hereby declare that the equipment named above has been designed to comply with the relevant sections of the above referenced specifications. The unit complies with all essential requirements of the Directives. The CE marking has been affixed on the device according to article 10 of the EC directive 89/336/EEC

Authorized Signatory

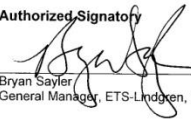
Bryan Saylor
General Manager, ETS-Lindgren, L.P.

30 January 2006

Date of Declaration:

The authorizing signature on the EC Declaration of Conformity document authorizes ETS-Lindgren, L.P. to affix the CE mark to the indicated product. CE marks placed on these products will be distinct and visible. Other marks or inscriptions liable to be confused with the CE mark will not be affixed to these products.

ETS-Lindgren, L.P. has ensured that appropriate documentation shall remain available on premises for inspection and validation purposes for a period of no less than ten (10) years

ETS-Lindgren L.P. · 1301 Arrow Point Drive · Cedar Park, Texas 78613 · Phone 512.531.6400 · Fax 512.531.6500
info@ets-lindgren.com · www.ets-lindgren.com

This page intentionally left blank.

Appendix C: Commands

For a list of FM5004 compatibility commands, see *Appendix D: Commands in FM5004 Mode* on page 65.

IEEE 488.2 Commands

Command	Description
*CLS	Clear status
*ESE	Event status enable
*ESR	Event status register
*IDN	Identification query
*OPC	Operation complete query
*RST	Reset
*SRE	Service request enable
*STB	Read status byte
*TST	Self-test query
*WAI	Wait to continue

Standard Commands

Command	Description
CHAN	Channel enable
LERR	Last error
LOCL	Local
RBAT	Read battery voltages
RECL	Recall
RPRB	Read probe
RTMP	Read probe temperatures
SAVE	Save setup

Command	Description
SREV	Software revision
RDPK	Read min/max peak
RSPK	Reset min/max peak
VERB	Verbose mode

Appendix D: Commands in FM5004 Mode

Unsupported Commands in FM5004 Mode

The following commands are not supported in either the HI-6100 mode or the FM5004 mode. In general, the HI-6100 Field Monitor does not have alarm or analog output capabilities. Functions to adjust the LCD and the display have also been removed.

ALARM FUNCTIONS



Alarm functions are not available on the HI-6100. These commands are included for test software compatibility purposes only and have no effect on the HI-6100. An error entry will be added to the CONTROLLER COMMUNICATIONS error list.

Command	Response
Alarm Latch	Where <i>m</i> is equal to the alarm mode: ALAT,m,0<LF>
Alarm Silence	Where <i>m</i> is equal to the alarm mode: ALOE,m,0<CR><LF>
Alarm Lower Enable	—
Alarm Lower Value	Where <i>m</i> is equal to the alarm type: ALOV,m,0<CR><LF>
Alarm Upper Enable	Where <i>m</i> is equal to the alarm type: AUPE,m,0<CR><LF>
Alarm Upper Value	Where <i>m</i> is equal to the alarm type: AUPV,m,0<CR><LF>

ANALOG OUTPUT FUNCTIONS



Analog output functions are not available on the HI-6100. These commands are included for test software compatibility purposes only and have no effect on the HI-6100. An error entry will be added to the CONTROLLER COMMUNICATIONS error list.

Command	Response
Analog Output Mode	ANAO,0<CR><LF>
Analog Output Range	ANAR,0<CR><LF>

OTHER COMMANDS



These commands are included for test software compatibility purposes only and have no effect on the HI-6100. An error entry will be added to the CONTROLLER COMMUNICATIONS error list.

Command	Response
Alternate Display Format	—
Buss Voltage	+12 - +12.00<CR><LF> +5V - +5.00<CR><LF> -12 - -12.00<CR><LF>
Filter Size	FTSZ,10<CR><LF>
Key Click	—
LCD Brightness	—
LCD Contrast	—
Log Scale	—

Command	Response
Sample Rate	SMPR,00<CR><LF> The sample rate is probe-dependent and set run as fast as possible.
System Alarm, Hard Probe Failure	—
System Alarm, Momentary Probe Failure	—
Display Update Rate	DUPR,5<CR><LF> The display update rate is fixed at 7 samples/second.

FM5004 Commands

IEEE 488.2 COMMANDS

Command	Description
*CLS	Clear status
*DDT	Device trigger
*ESE	Event status enable
*ESR	Event status register
*IDN	Identification query
*OPC	Operation complete query
*RST	Reset
*SRE	Service request enable
*STB	Read status byte

Command	Description
*TRG	Trigger
*TST	Self-test query
*WAI	Wait to continue

SUPPORTED COMMANDS

Command	Description
BAUD	Baud rate entry
CHRA	Change probe range
CLED	Channel LEDS
DSFM	Display format
GPIB	GPIB address
LERR	Last errors
LOCL	Local
RBAT	Read battery voltage
RDIS	Read display
RECL	Recall
RTMP	Read probe temperature
REMT	Remote
SREV	Software revision
SAVE	Save setup
VERB	Verbose mode
ZERO	Zero probes

UNSUPPORTED COMMANDS

Command	Description
ADFM	Alt Display Format
ALAT	Alarm Latch
ALOV	Alarm Lower Value
ALOE	Alarm Lower Enable
ALSR	Alarm Silence
ANAO	Analog out
ANAR	Analog Range
AUPE	Alarm Upper Enable
AUPV	Alarm Upper Value
BUSV	Buss Voltage
CLCK	Key Click
DATE	Software Date
DUPR	Display Update Rate
ERRQ	Error Register Query
FTSZ	Filter Size
HELP	This command
LCDB	LCD brightness
LCDC	LCD Contrast
LOGS	Log Scale
RDMD	Read Display Mode
SALH	System Alarm Hard Probe Fail
SALM	System Alarm Momentary Fail
SALS	System Alarm System Fail
SMPR	Samples/second

This page intentionally left blank.

Appendix E: GPIB Register

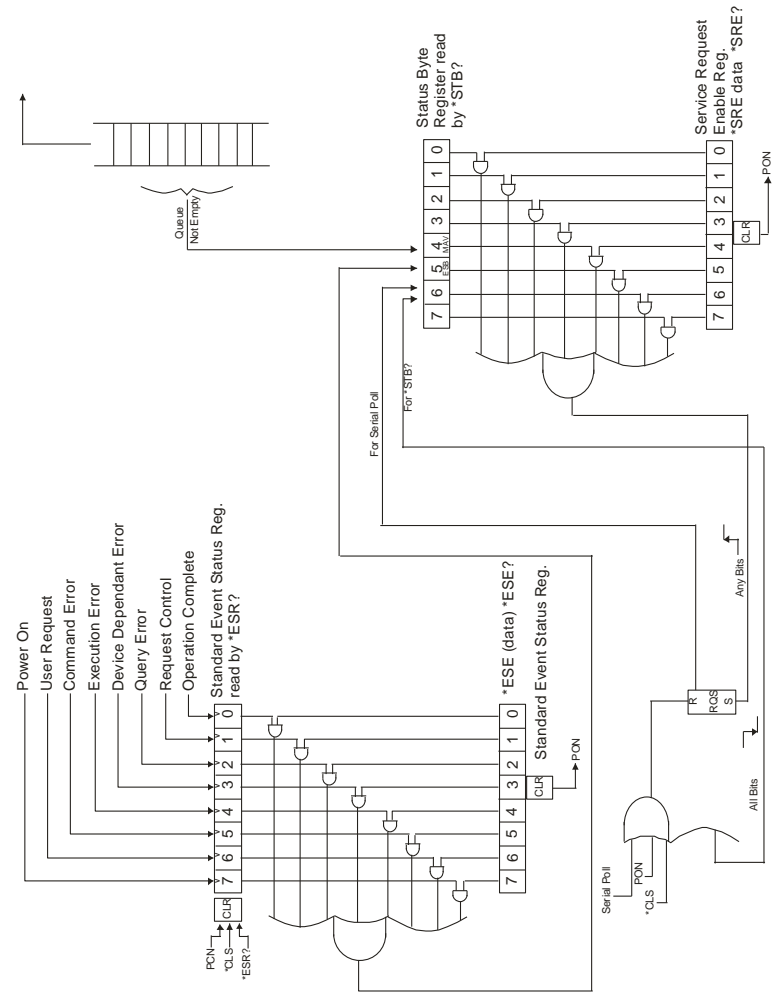

Figure 36: GPIB Registers