



**Advanced Test Equipment Rentals**  
**www.atecorp.com 800-404-ATEC (2832)**

# **OR1400**

## **Oscillographic Recorder**

# Introduction

Thank you for purchasing the YOKOGAWA OR1400 Oscillographic Recorder.

This User's Manual will acquaint you with the features of your new recorder, tell you how to use it and present other useful information. Please read it carefully before use.

If you have already a working knowledge of pen or electromagnetic oscillographic recorders, you will find this manual useful as a reference tool. In particular, you will find the Operation Guide (IM 783001-02E) both useful and time saving. If, on the other hand, this is your first time to use an oscillographic recorder, you can easily become adept by reading the guide from the beginning. Also, when you use your recorder, we suggest that you keep this manual handy for quick, on-the-spot reference.

If you have chosen the optional GP-IB or RS-232-C communications interface, the GP-IB/RS-232-C Interface User's Manual (IM 781011-11E) will give you the additional information you need to set up your recorder for remote control operation.

## NOTES

- Make sure that when using this instrument in combination with a personal computer, CRT, or external key board, these equipment have the CE-mark.
- YOKOGAWA reserves the right to change the operation or specifications of the recorder at any time without notice.
- If you find any errors or ambiguities in this manual, please inform YOKOGAWA.
- No part of this manual may be reproduced or recreated, in any form or by any means, without the express prior permission of YOKOGAWA.
- IBM is a registered trademark of International Business Machines Corporation.
- MS-DOS is a registered trademark of Microsoft Corporation.

## REVISIONS

First edition : February 1995

Second edition : March 1995

Third edition : December 1995

### Checking Model Code

When you receive your recorder, check the information on the nameplate to confirm that it is as specified by your order. The nameplate is located at the rear panel.

#### Model Code

783001 : OR1400 Oscillographic Recorder

S2 : Style number

#### Suffix Code

Code	Specification
- D	UL, CSA standard power supply cord
- F	VDE standard power supply cord
- R	SAA standard power supply cord
- J	BS standard power supply cord
/C1	GP-IB interface
/C2	RS-232-C interface
/D2	*F display
/N4	Logic input
/V1	External monitor output interface
/C5	External keyboard setup interface

#### Input unit

Model	Description
783051	Voltage input unit
783052	Universal input unit
783053	RMS converter unit
783054	Strain input unit
783055	Frequency input unit
783056	Power line freq. input unit

## Checking Accessories and Appearance

Your recorder should be accompanied by the standard accessories indicated in figure "Standard Accessories". Check that all are present in the correct quantities. When other accessories, specified by your order, are present, check these also. Consumables should be present too and are indicated in figure "Spares". Also check the external appearance of your recorder to ascertain that no damage has occurred. If you discover any problem concerning the quantity of accessories or external appearance, contact your sales representative.

### Standard Accessories

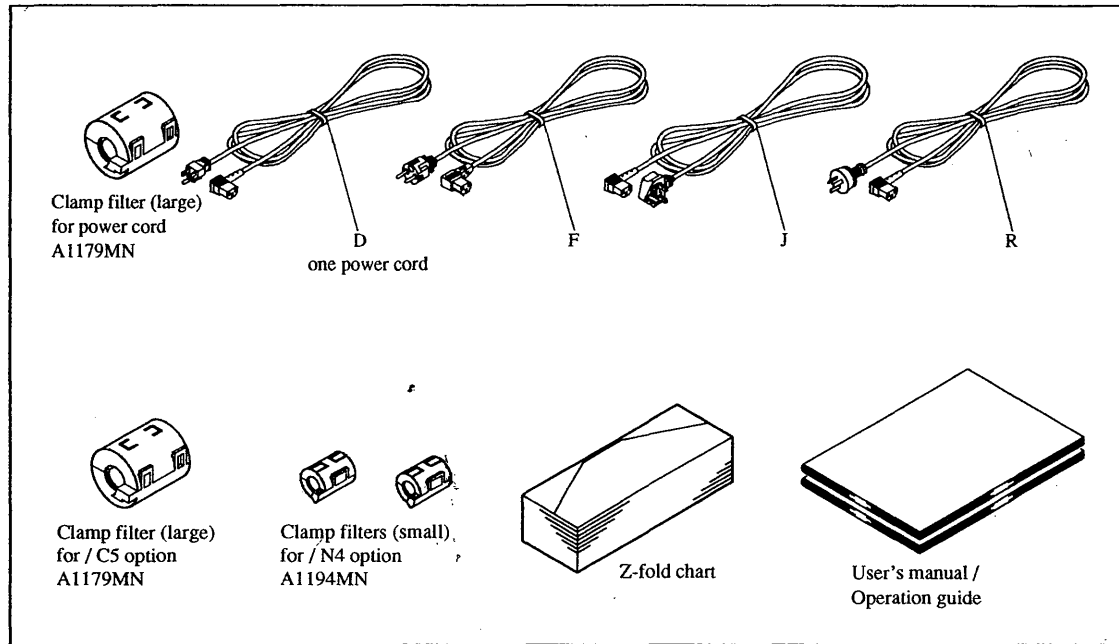

### Optional Accessories

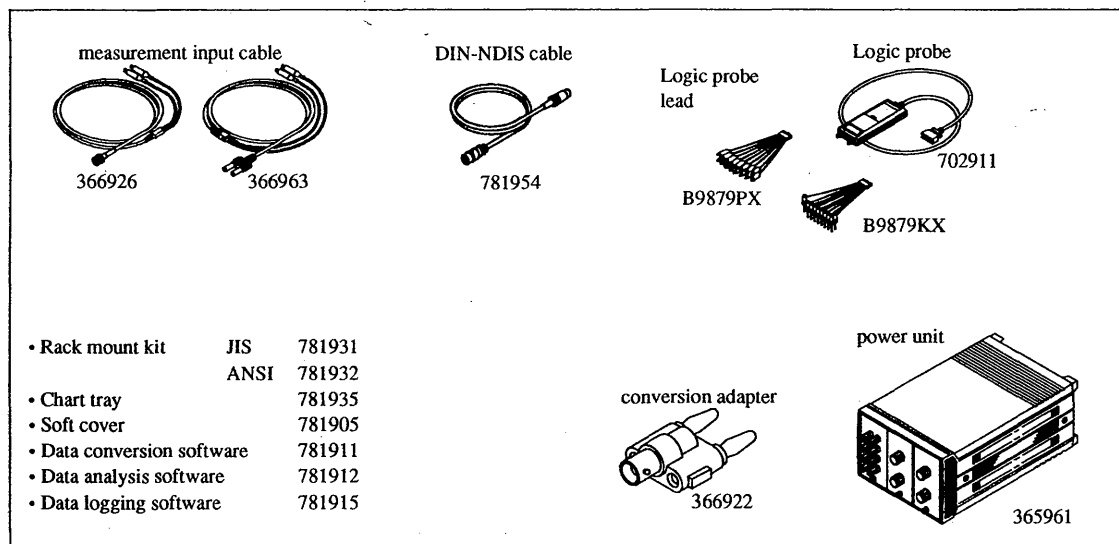

### Spares

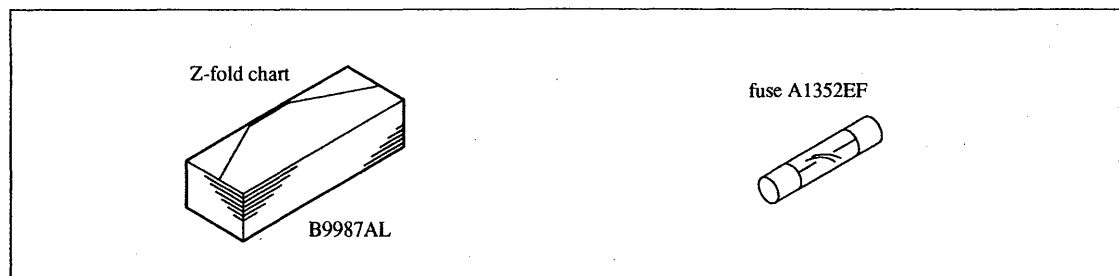

# Safety Precautions

This is a Safety Class I Instrument (provided with terminal for protective earthing).

The following general safety precautions must be observed during all phases of operation, service, and repair of this instrument. Failure to comply with these precautions or with specific WARNINGS given elsewhere in this manual violates safety standards of design, manufacture, and intended use of the instrument.

YOKOGAWA ELECTRIC CORPORATION assumes no liability for the customer's failure to comply with these requirements.

General definitions of safety symbols used on equipment and in manuals.



To avoid injury, death of personnel or damage to the instrument, the operator must refer to an explanation in the user's manual.



Power switch is ON, and therefore power is being supplied to the instrument.



Power switch is OFF, and therefore power is not being supplied to the instrument.



AC power supply



Grounding Function Terminal

## WARNING

A WARNING sign denotes a hazard. It calls attention to a procedure, practice, condition or the like, which, if not correctly performed or adhered to, could result in injury or death of personnel.

## CAUTION

A CAUTION sign denotes a hazard. It calls attention to a procedure, practice, condition or the like, which, if not correctly performed or adhered to, could result in damage to or destruction of parts of the product.

## WARNING

### Power Supply

Ensure the source voltage matches the voltage of the power supply before turning ON the power.

### Power Cord and Plug

To prevent an electric shock or a fire, be sure to use the power supply cord and the 3-to-2 pin adapter supplied by YOKOGAWA. The main power plug must be plugged in an outlet with protective grounding terminal. Do not invalidate protection by using an extension cord without protective grounding.

### Protective Grounding

Make sure to connect the protective grounding to prevent from an electric shock before turning ON the power.

### Necessity of Protective Grounding

Never cut off the internal or external protective grounding wire or disconnect the wiring of the protective grounding terminal. Doing so poses a potential shock hazard.

### Fuse

To prevent a fire, make sure to use fuses with specified standard (current, voltage, type). Before replacing the fuses, turn off the power and disconnect the power source. Do not use a different fuse or short-circuit the fuse holder.

### Do Not Operate in an Explosive Atmosphere

Do not operate the instrument in the presence of flammable liquids or vapors. Operation of any electrical instrument in such an environment constitutes a safety hazard.

### Never Touch the Interior of the Instrument

Inside this instrument there are areas of high voltage; therefore, never touch the interior if the power supply is connected. The cover should be removed by properly trained personnel only.

### External Connection

To ground securely, insert the main power plug before connecting to measurement or control units.

### Signal Cables



All signal cables which are connected to the OR1400 should not be used for process control.

# How to Use this Manual

This manual is divided into twelve chapters, an appendix and an index as described below. Chapters 1 and 2 give an introduction to the recorder. Please read chapter 1 before using the recorder for the first time. Chapters 3 through 9 describe all aspects concerning the operation of the recorder. Chapters 10 through 12 are useful when problems occur or when maintenance needs to be carried out.

Chapter	Title	Description
1	Overview	Describes the features and functions of the OR1400 and its parts.
2	Before Operation	Gives a list of the package contents upon receipt, describes handling precautions and the way to install the recorder. Furthermore, this chapter also describes how to connect the power cord, input unit and cables and how to load the chart.
3	Basic Operation	Describes how to switch the recorder on and off and how to enter settings. This chapter also describes how to set up the input signal settings, monitor data on the screen and how to set the date and time.
4	Real-Time Recording	Describes how to record input signals and how to set the recording format or printing of various information in real time.
5	Data Capture	Describes how to capture data and how to store data into the memory.
6	Triggering	Describes how to set trigger conditions for real-time recording, data capture or chart speed change.
7	Printing and Displaying Captured Data	Describes how to display captured data on the screen and how to print them onto the chart; describes how to use the mathematical function.
8	Floppy Disks	Describes how to save setups and measurement data to a floppy disk and how to load them.
9	Miscellaneous Functions	Describes how to perform linear scaling, initialize settings, print a setup list, start and stop by external input, and other functions.
10	Trouble-Shooting	Describes how to find the causes of malfunctioning, take corrective measures and act on messages.
11	Testing and Maintenance	Describes procedures on how to test some functions, clean the printing head and replace the fuse.
12	Specifications	Lists the recorder's specifications and functions.

# Contents





<b>Introduction</b>	<b>1</b>
<b>Safety Precautions</b>	<b>4</b>
<b>How to Use this Manual</b>	<b>5</b>
<b>Chapter 1 Overview</b>	
1.1 Features .....	1-1
1.2 Functions .....	1-1
1.2.1 Input Capabilities .....	1-1
1.2.2 Real-Time Recording Capabilities .....	1-2
1.2.3 Data Capture Capabilities .....	1-6
1.2.4 Other Useful Functions .....	1-8
1.3 Nomenclature .....	1-9
1.3.1 Front Panel .....	1-9
1.3.2 Key Panel .....	1-10
1.3.3 Rear Panel .....	1-12
1.4 Operation Flow Chart .....	1-13
<b>Chapter 2 Before Operation</b>	
2.1 Handling Precautions .....	2-1
2.1.1 Handling Precautions for the Recorder .....	2-1
2.1.2 Handling Precautions for the Printer Head .....	2-1
2.2 Installing the Recorder .....	2-2
2.3 Installing the Input Unit .....	2-3
2.4 Mounting the Rack .....	2-4
 2.5 Connecting the Power Cord and Signal Cables .....	2-4
2.5.1 Connecting the Power Cord .....	2-4
2.5.2 Connecting Measurement Inputs .....	2-5
2.5.3 Connecting the Gage (for strain input unit only) .....	2-6
2.5.4 Connecting External I/O Control Signals .....	2-7
2.5.5 Connecting Logic Input Signals (option) .....	2-8
2.5.6 External Monitor Output (option) .....	2-9
2.5.7 The External Keyboard (option) .....	2-9
2.5.8 Applying a Clamp Filter .....	2-11
2.6 Loading the Chart .....	2-12
2.7 Handling Precautions for the Charts .....	2-12
2.8 Using the Chart Tray (option) .....	2-13
<b>Chapter 3 Basic Operation</b>	
 3.1 Switching the Recorder ON/OFF .....	3-1
3.2 How to Enter Settings .....	3-1
3.3 Input Signal Settings .....	3-3
3.3.1 How to Set the Input Type and Filter .....	3-3
3.3.2 How to Set the Measurement Range and Full Scale Values .....	3-4
3.3.3 How to Set a Suppression Voltage .....	3-6
3.3.4 Calibration for RMS Measurement (only when RMS converter unit is applied) .....	3-7
 3.3.5 Setting the Bridge Excitation Voltage (only for strain input unit) .....	3-7
3.3.6 Adjusting the Strain Balance (only for strain input unit) .....	3-8
3.3.7 How to Copy Settings to An Other Channel .....	3-8
3.4 Using the Monitor Screen .....	3-9
3.4.1 Switching Between Monitor Screens .....	3-9
3.4.2 Freezing the Monitor Screen .....	3-10
3.4.3 Getting a Manual Printout .....	3-10
3.5 Date and Time Settings .....	3-11
3.6 Changing the Language of the Display .....	3-11

<b>Chapter 4</b>	<b>Real-Time Recording</b>	
4.1	Initial Recording Settings .....	4-1
4.2	Starting/Stopping Real-Time Recording .....	4-3
4.3	Chart Speed Setting .....	4-3
4.4	Fixed and Flexible Zone Recording .....	4-4
4.5	Selecting the Grid Type and Grid Intensity .....	4-6
4.6	Entering and Printing Messages .....	4-6
4.7	Printing Channel Numbers .....	4-8
4.8	Printing the Scale .....	4-8
4.9	Entering and Printing the Header .....	4-9
4.10	Selecting Trace Intensity and Turning Channels OFF .....	4-10
4.11	Inverting the Recording .....	4-10
4.12	X-Y Recording .....	4-11
4.13	Digital Logging Recording .....	4-12
4.14	Orientation of the Printout .....	4-12
4.15	Single-Shot Recording .....	4-13
4.16	Printing the Time Tick or Event Marker .....	4-13
4.17	Logic Recording .....	4-14
<b>Chapter 5</b>	<b>Data Capture</b>	
5.1	Initial Settings .....	5-1
5.2	Setting the Sample Rate .....	5-2
5.3	Setting the Memory Length .....	5-2
5.4	Memory Partitioning .....	5-3
5.5	Starting/Stopping Data Capture .....	5-4
<b>Chapter 6</b>	<b>Triggering</b>	
6.1	Initial Settings and Overview .....	6-1
6.2	Selecting the Trigger Type .....	6-2
6.3	Selecting the Trigger Action .....	6-3
6.4	Selecting the Trigger Mode .....	6-4
6.4.1	Selecting the Trigger Mode in Case of Triggering Real-Time Recording ....	6-4
6.4.2	Selecting the Trigger Mode in Case of Triggering Data Capture .....	6-4
6.5	Setting Pre- or Post-Trigger Conditions .....	6-5
6.6	Selecting AND/OR Triggering .....	6-6
6.7	Setting Trigger Conditions .....	6-7
6.8	Setting Window and Bi-Slope Triggering .....	6-8
6.9	Logic Trigger .....	6-9
<b>Chapter 7</b>	<b>Printing and Displaying Captured Data</b>	
7.1	Printing Captured Data as Analog Waveforms .....	7-1
7.2	Printing Captured Data as Numeric Values .....	7-3
7.3	Printing Captured Data by the Auto Mode Function .....	7-4
7.4	Printing Captured Data Blocks .....	7-5
7.5	Selecting a Section of the Captured Data .....	7-6
7.6	Displaying Captured Data on the Screen as Analog Waveforms ..	7-7
7.6.1	Displaying Data Digitally and Zooming In on Analog Waveforms .....	7-8
7.6.2	Retrieving Waveforms Using the Auto Mode Function .....	7-10
7.6.3	Changing the Scale of the Waveform .....	7-10
7.7	How to Use the Mathematical Function .....	7-11
7.7.1	Performing Arithmetic Computations Between Channels/Comparing Data on the Same Time Axis .....	7-11
7.7.2	Performing Statistical Computation .....	7-12
7.7.3	Statistical Computation by Auto Mode Function .....	7-14
<b>Chapter 8</b>	<b>Floppy Disks</b>	
8.1	Using Floppy Disks Properly .....	8-1
8.2	Formatting a Floppy Disk .....	8-1
8.3	Saving Setups .....	8-2
8.4	Saving Measurement Data .....	8-3



8.5 Saving Captured Data .....	8-5
8.6 Loading Setups or Measurement Data .....	8-5
8.7 Deleting Setups or Measurement Data .....	8-6
8.8 Displaying Information on Measurement Data Files .....	8-6
8.9 Saving Captured Data to the Floppy Disk by Auto Mode Function .....	8-7
8.10 Using the Dump Function .....	8-8
8.11 Data Compatibility .....	8-9

**Chapter 9 Miscellaneous Functions**

9.1 Linear Scaling .....	9-1
9.1.1 Linear Scaling for Strain Measurement Data .....	9-3
9.2 Resetting Control Settings and Memory .....	9-4
9.3 Changing System Settings .....	9-4
9.4 Printing a Setup List .....	9-5
9.5 Getting a Hardcopy of the Display .....	9-5
 9.6 Using an External Control to Start/Stop .....	9-6
 9.7 Changing the Chart Speed Using an External Control .....	9-7
 9.8 Entering an Event Marker Using an External Control .....	9-8
 9.9 Data Capture Using an External Sampling Clock .....	9-9
 9.10 Operating Multiple Recorders in Parallel .....	9-10
9.11 Checking Sampling Conditions .....	9-11
9.12 Saving/Loading a Backup of the Recorder's Setup .....	9-12

**Chapter 10 Trouble-Shooting**

10.1 Diagnosing the Problem .....	10-1
10.2 Messages .....	10-3

**Chapter 11 Testing and Maintenance**

11.1 Testing the Panel Keys and Rotary Knob .....	11-1
11.2 Testing the Memory .....	11-1
11.3 Checking the Thermocouple Accuracy .....	11-2
11.4 Cleaning the Printer Head .....	11-2
11.5 Replacing the Fuse .....	11-3

**Chapter 12 Specifications**

12.1 Measurement Inputs .....	12-1
12.2 Recording .....	12-8
12.3 Data Capture .....	12-9
12.4 Triggering .....	12-10
12.5 Display .....	12-10
12.6 External I/O Signals .....	12-11
12.7 General Specifications .....	12-11
12.8 3.5Inch Floppy Disk .....	12-12
12.9 Options/Accessories .....	12-12
12.10 Warranted Characteristics-EMC and Safety Conformity Standard .....	12-13
12.11 External Dimensions .....	12-14

**Appendix A System Configuration & Block Diagram**

**Appendix B Initial Settings**

**Appendix C English, German and French Displays**

**Index**

# Overview

This chapter describes the features and functions of your recorder, together with the names of components and an operation flow.

## 1.1 Features

The YOKOGAWA OR1400 Oscillographic Recorder is a completely new type of oscillographic recorder. It improves on the high functionality you would expect from a conventional thermal array recorder, while giving you the excellent recording characteristics typical of pen recorders and electromagnetic oscillographs, without the troublesome maintenance.

- Fast, 250 mm/s chart speed which is ideal for real-time recording.
- Wide, 201 mm effective recording span. Additionally printed information, such as annotations, are completely printed within this span. Only analog waveforms use the maximum 200 mm span.
- Proprietary dot-overlap technology that increases the time axis resolution to 32dots/mm, four times more than you get with conventional portable thermal array recorders, for high-quality recording at chart speeds of up to 200 mm/s.
- High, 100 kHz sample rate that lets you record high-speed phenomena with frequencies of up to 10 kHz.
- Superior, user-friendly interfaces, including an easy-to-read LCD display, a rotary knob for the "feel" of analog controls, and key-touch operation.
- Wide range of recording formats and additional data print options that let you customize your printouts.
- 1Mdata/channel of memory for data storage (4-channel model). Note that you can also use data capture during real-time recording.
- In case of the universal input unit, you get a high resolution, 14-bit A/D converter in the input stage, a direct connection for eleven types of thermocouple and a max. 8-channel multipoint connection.
- In case of the voltage input unit, you get a high resolution, 12-bit A/D converter in the input stage, where the max. input range is 500V and the max. allowable input voltage is 350V.
- Using the RMS converter unit, the effective value of AC voltages can be measured.
- After connecting the strain gage or strain gage converter to the strain input unit, the load, acceleration, etc. of the strain phenomenon can be measured.
- After inputting a sine wave or pulse waveform signal to the frequency input unit, the frequency of the input waveform can be measured.
- Using the input unit for power supply frequency, the frequency fluctuation can be measured at a 2 Hz span and with a 0.01 Hz resolution.
- Wide range of selectable trigger conditions for both real-time recording and data capture.
- Features mathematical functions, such as waveform math and statistical computations.
- Optional logic input available.
- At approximately 6.8 kg, this portable recorder combines light weight and high performance.

## 1.2 Functions

### 1.2.1 Input Capabilities

#### Measurement Input

All you have to do is to connect a DC-coupled voltage or thermocouple input, and then set the input type and measurement range on the display. You can select up to 8 input channels, depending on your model.

Input Mode	DC-coupled voltage (except for frequency input units), thermocouple input (for universal unit only), AC-coupled voltage (for frequency input unit only).
Voltage Input Range	Universal unit : 50mV to 50V Voltage unit and frequency units : 100mV to 500V Strain unit : 1mV to 20mV
Thermocouple	K, J, E, T, L, U, R, S, B, N, W
Strain Input Range	100 $\mu$ e to 20000 $\mu$ e
Frequency Input Range	50 Hz to 10000 Hz

Furthermore, you may input up to 16 logic input channels.

#### Input Filters

Each channel has a 1.5 Hz cutoff frequency (frequency of 3dB attenuation) line filter (50dB attenuation at 50/60 Hz) and a lowpass filter (12dB/octave attenuation) with user-selectable cutoff frequencies (except for the RMS mode of the RMS converter unit, where there is no filter). Always select the cutoff frequency which best matches your measurement input.

Selectable frequencies are

for the universal input unit: 1.5 Hz, 40 Hz, 400 Hz, 4kHz

for the voltage input unit, and for DC coupled voltage of the RMS converter unit and for the strain input unit : 1 kHz, 100 Hz, 10 Hz

for the frequency input unit and input unit for power supply frequency : the cutoff-frequency will be automatically assigned according to the measurement range as shown below.

Measurement Range	Cutoff Frequency
100 Hz	100 Hz
200 Hz	1000 Hz
500 Hz	1000 Hz
1000 Hz	1000 Hz
2000 Hz	10000 Hz
5000 Hz	10000 Hz
10000 Hz	10000 Hz
50 Hz	100 Hz
60 Hz	100 Hz

#### A/D Converter

Each channel has a 14-bit (universal input unit) or 12 bit (voltage input unit), max. 100 kHz analog-to-digital converter, which ensures simultaneity of measurement data, high resolution and wide dynamic range.

## 1.2.2 Real-Time Recording Capabilities

You can record input measurement data from each channel in real time directly onto the chart with a 201 mm effective recording span. You can select analog waveform recording or digital logging recording.

### Analog Waveform Recording

In the real-time recording mode, you can record measurement data either as analog waveforms or as numeric values.

#### A Analog Waveform Recording Formats

##### Fixed Zone Recording

You can subdivide the chart recording area into 1, 2, 4, or 8 (depending on your model) equal zones. In each zone, you can record a single channel or a group of channels. See figure 1.1.

##### Flexible Zone Recording

The recording zone of each channel can be designated in 1 mm units within a 0 to 160 mm or 200 mm range. This function allows channel waveforms to overlap each other, including full overlap. See figure 1.2.

### Dark/Light Trace Recording

You can set the trace intensity of waveforms to either dark or light to help distinguish between waveforms that over-lap each other. Note that this function is not available for X-Y recordings.

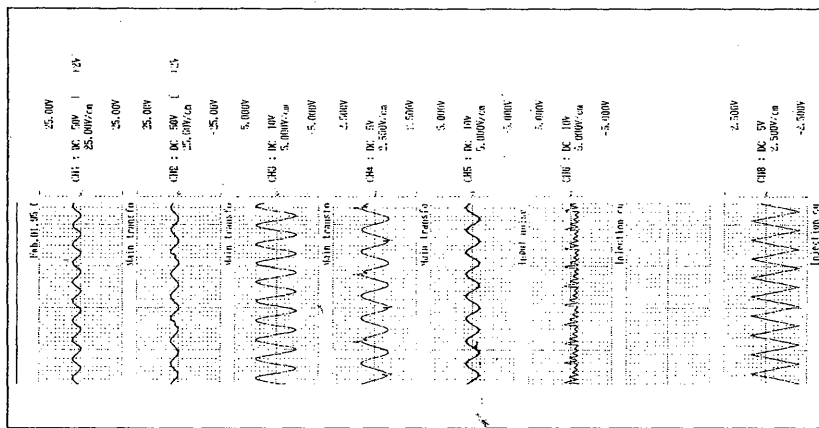
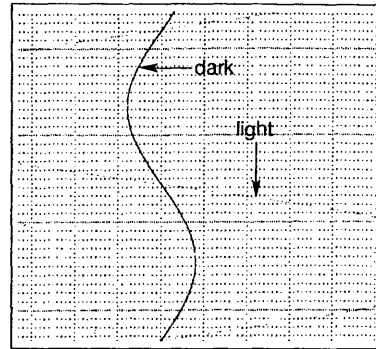

fig. 1.1. Fixed Zone Recording Example

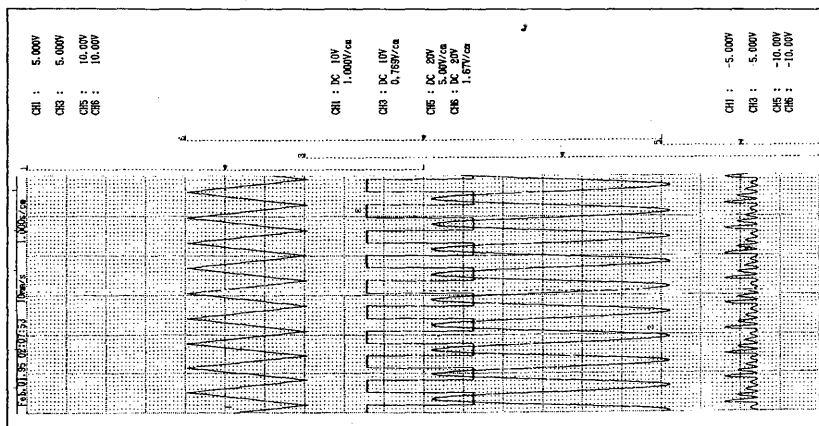
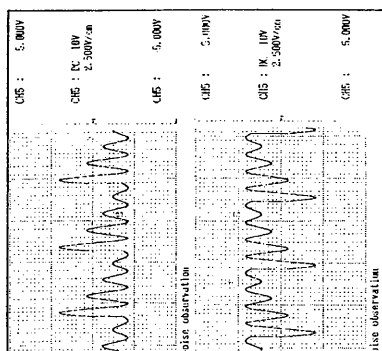

fig. 1.2. Flexible Zone Recording Example

**Inverted Recording**

You can invert the sign of the Y-axis to place positive Y-axis values towards the right hand edge of the chart.



**X-Y Recording**

You can observe the phase relationship between input channels. You can print the grid, scale, message, channel numbers and start/stop time in the X-Y recording mode.

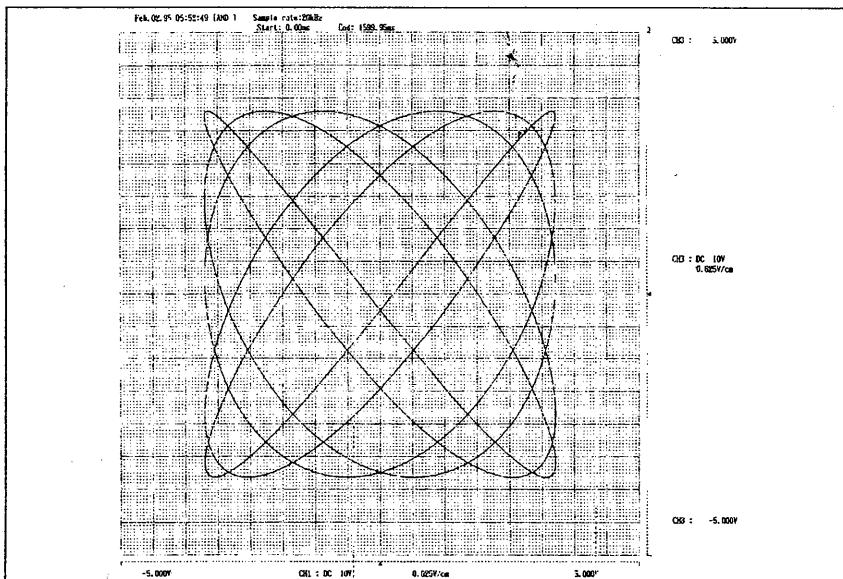

**Single Shot Recording**

You can limit the amount of chart paper used during a single recording to one of four options, which are 0.2, 0.5, 1 or 2 m.

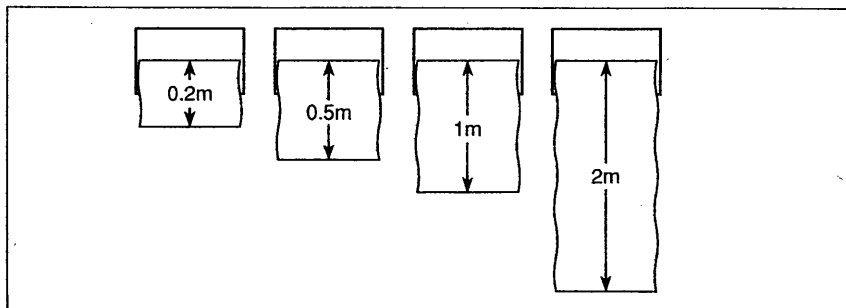

## B Additional Print Information

The analog waveform recording mode lets you record the measurement data. But you can also print the following additional information useful for data observation or analysis.

### Scale (see 4.8)

Scale indicates the maximum and minimum full-scale value that can be printed and the corresponding axis divisions. The units previously set for each channel are also printed. Note that it is possible to set up your own scale values and units using the linear scale function.

### Header (see 4.9)

This is the chart header which can consist of up to 60 characters.

### Chart Speed (see 4.3)

This is the chart (feeding) speed at the time of the recording, and time elapsed per 1 cm.

### Date and Time (see 4.9)

This is the date and time of the recording. The time corresponds with the nearest main vertical grid line before the first character of the printout. When the external time code option is used, a timetick will be printed in front of the date and time.

### Channel Number (see 4.7)

This is the number of the waveform channel.

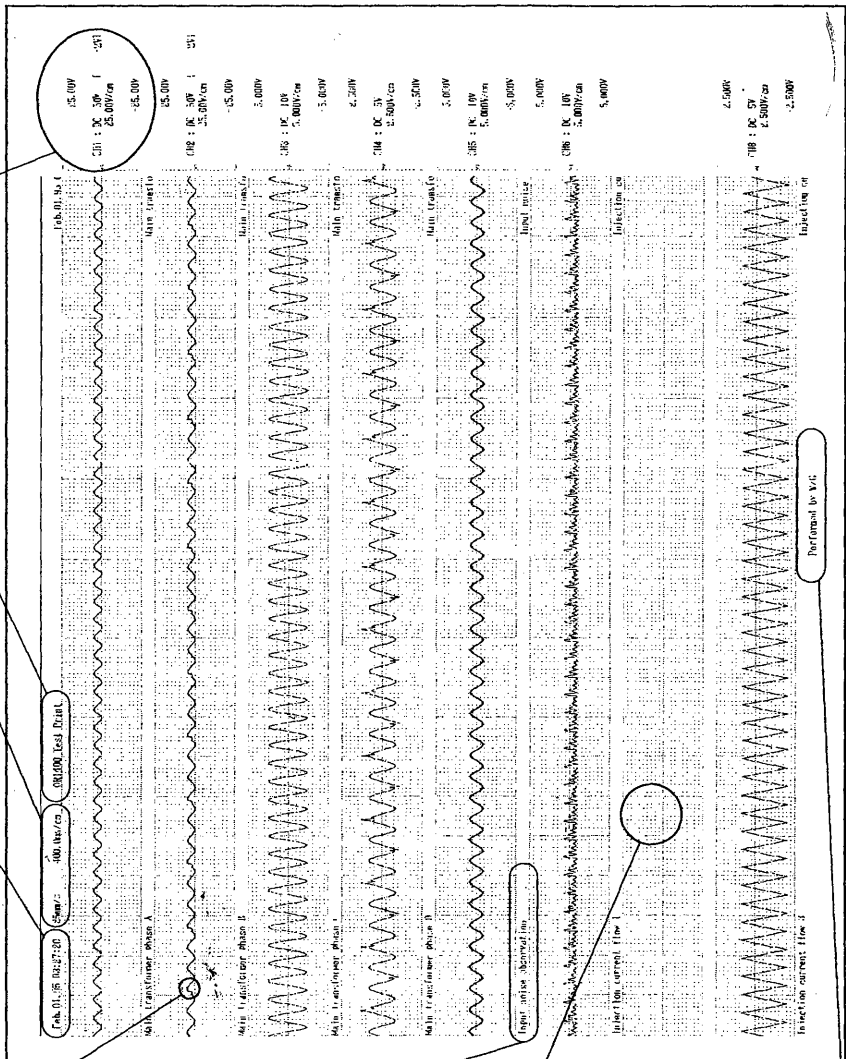

### Annotation (see 4.6)

This is a text field corresponding to the channel for printing information such as the name of the input signal. It is also possible to print other information here, such as range settings.

### Grid (see 4.5)

This indicates the amplitude and time scale gradations for measuring waveform amplitudes and elapsed time. You have a choice of four types of grid and two types of intensity.

### Event Message (see 4.6)

This is a text field not relating to any channel for printing additional information, which can be triggered any time manually or by external control.

### Digital Logging Recording

Digital logging recording mode lets you record the measurement data of each channel at preset intervals as numeric values. Note that you can choose from two orientations of the printout, namely normal and 180° rotated.

01:24:30	4.760	1.281	0.77	2.504	-1.217	-1.687	0.634	-0.987
01:24:29	0.302	1.301	0.74	2.463	0.248	-1.572	0.290	-0.426
01:24:28	4.982	1.301	0.77	2.107	-0.182	-0.005	-0.032	-0.383
01:24:27	0.544	1.281	0.76	1.582	-1.662	-1.061	-0.383	-1.024
01:24:26	4.256	1.281	0.73	0.888	-2.031	-0.920	-0.700	0.198
01:24:25	1.566	4.175	0.68	0.148	-1.170	-1.741	-0.929	-1.602
01:24:24	2.992	4.182	0.66	-0.618	-0.605	-1.438	-0.605	0.783
01:24:23	3.059	4.182	0.69	-1.332	-1.318	1.160	-0.255	-1.844
01:24:22	1.499	4.175	0.69	-1.810	-2.058	-0.617	0.068	0.434
01:24:21	4.357	4.189	0.77	-2.065	-1.863	-0.455	0.412	-1.263
01:24:20	0.463	4.189	0.70	-2.059	-1.312	-1.734	0.722	-0.151
01:24:19	4.989	4.189	0.69	-1.810	-1.271	-1.196	1.031	-0.675

**Numeric Values** (see 4.13)  
These are the measured values of the input signal at preset intervals in units determined by the scale setting.

**Date and Time** (see 4.9)  
This is the date and time at which the input signal was measured.

**Suppression Voltage** (see 3.3.3)  
This is the suppression voltage which can be set for each channel.

**Channel Number** (see 4.7)  
This is the channel number of the input signal.

### Monitor Screen Functions

You can monitor the analog waveforms, numeric values of the measurement input or logic input waveforms on the screen. You can use this screen to check the recording position before recording onto a chart. You can also use this screen to check full-scale values for any channel during analog waveform recording. The data on the monitor screen can also be inverted.

#### Analog Waveform Display

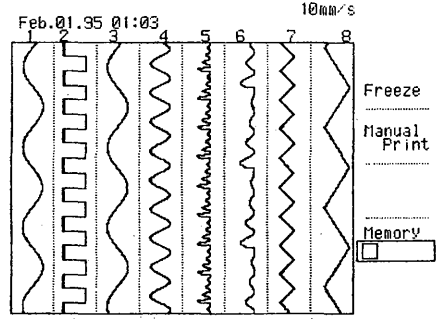

#### Logic Waveform Display

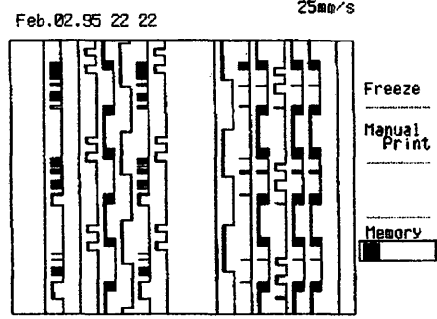

#### Numeric Values Display

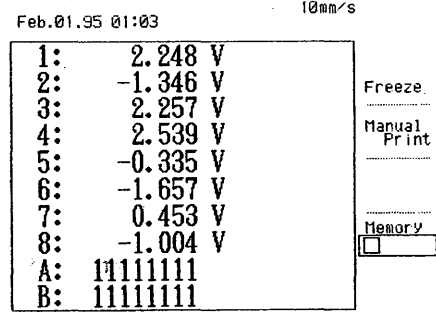

#### Full-Scale Values Display

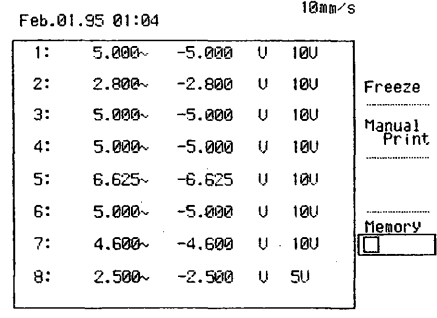

## 1.2.3 Data Capture Capabilities

### Memory Functions

#### Data Capture

The OR1400 can sample the measurement input and then store the sampled data into memory. You will find this useful when recording signals that change too rapidly to be recorded directly onto the chart in real time. In the data capture mode, you can set the optimum of data capture for measurement input by varying the setting of the sample rate, memory length and number of memory blocks to be used.

#### Sample Rate

This is the rate at which the input signal is sampled and then stored into memory. The following sample rates are selectable: 0.1, 0.2, 0.5, 1, 2, 5, 10, 20, 50, 100, 200 and 500 Hz, and 1, 2, 5, 10, 20, 50 and 100\*kHz (depending on your model). Using an external sampling clock input signal, measurement data can be sampled up to 100\*kHz.

\* When real-time recording is in progress, the sample rate can be max. 50kHz.

#### Memory Length

This is the amount of memory allocated to each channel for data storage. This memory length determines the number of sampling (for example, 1000 data).

The following memory length settings are selectable : 1, 2, 4, 8, 16, 32, 64, 128, 256, 512k, 1M<sup>2</sup> data.

<sup>1</sup>In this case you can only use channel 1, 3, 5 and 7 for measurements.

<sup>2</sup>In this case you can only use channel 1 and 5 for measurements.

#### Memory Coupling

You can re-locate the memory by using only a limited number of channels. When you are filling all channels, each channel can use a memory of up to 256kdata. However, when using channel 1, 3, 5 and 7 only, you can use up to 512kdata. Use only channel 1 and 5 and you can use up to 1 Mdata. The situation for the 8-channel mode is as shown in the figure below.

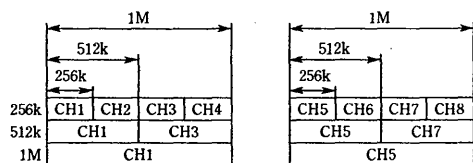

If the memory length is set to 512k or 1Mdata, the memory will be coupled automatically as shown above. Therefore, pay attention to connect the input units to the proper channels.

#### Number of Memory Blocks

This is the number of blocks into which sampled data is stored. Blocks are filled sequentially when you start recording, either manually or in response to a trigger signal. You can specify 1, 2, 4, 8 or 16 memory blocks, depending on the memory length setting. Refer to the figure below.

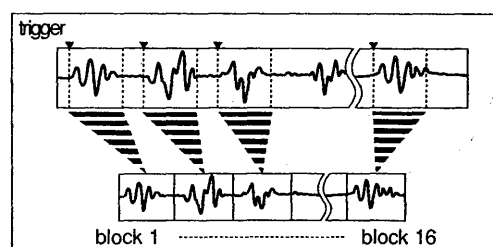

#### Printing Captured Data

You can print captured data onto the chart as analog waveforms or numeric values. In addition, you can choose either partial or complete recording of the captured data. In the analog waveform recording mode, you can also print the time scale and trigger time.

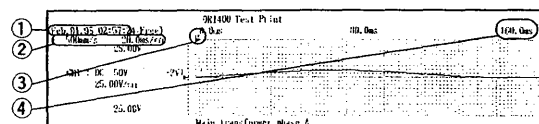

#### ① Trigger Date and Time

This is the date and time at which trigger conditions were satisfied, and only appears when the scale printing is ON.

#### ② Effective Chart Speed

This is the chart speed equivalent to the time scale.

#### ③ Trigger Mark

This indicates the point of triggering. When scale printing is OFF, the trigger time appears here as well.

#### ④ Time Scale

This indicates the scale of the time axis.

#### Paper Format

The size of the paper on which you are printing captured data can be selected from the following: Strip Chart, A4 size and A5 size. See 7.1.

#### • Displaying Captured Data

You can display captured data as an analog waveform.

#### • Data Capture during Real-Time Recording

You can trigger input measurement sampling and then store the sampled data in memory during real-time recording. This allows high-resolution recording of the events you want to capture.

**Auto-Print Function**

With the auto-print function, real-time recording is automatically suspended and the captured data printed directly to the chart whenever the available memory (or memory blocks when memory is partitioned) runs out.

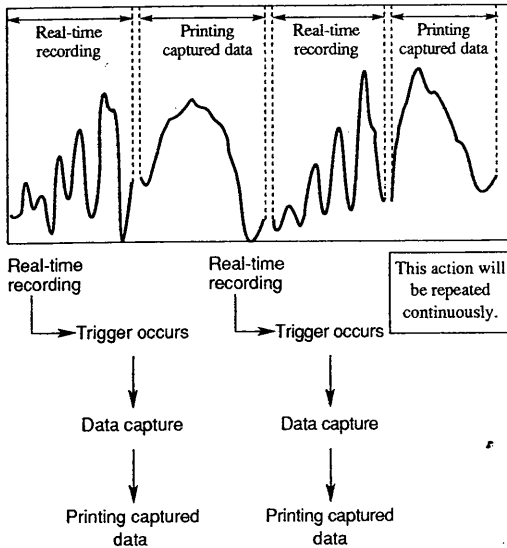
**Triggering**

You can set a variety of trigger conditions to trigger real-time recording, data capture or chart speed change.

**Type**

This lets you select whether to set one trigger condition for each channel or more than one condition for the same channel.

**Action**

This lets you select whether to start real-time recording, data capturing or changing the chart speed after a trigger occurs.

**Mode**

The available settings depend on the previous action setting.

**Repeat**

This lets you start recording each time the preset trigger conditions are met.

**Repeat Rotate**

This lets you start data capturing each time the preset trigger conditions are met, and when the memory runs out, previous data will be overwritten in the same order.

**Repeat Sequence**

This lets you start data capture each time the trigger conditions are met, and when the memory runs out, data capturing will stop.

**Single**

This lets you start a single recording or capture data into memory when the preset trigger conditions are met.

**Free**

This lets you start recording or capture data into memory immediately, regardless of the current trigger conditions.

**Pre- or Post-Trigger**

This lets you specify the amount of memory to set aside for data sampled before the trigger (pre-trigger), which is specified as a percentage of the total memory length (-100 to 0%).

This setting can also be used to set the post-trigger, which specifies the time delay before a data sample will be taken after a trigger occurs. You specify this as a percentage of the total memory length (0 to 1000%).

**AND/OR Trigger****AND**

This lets you start recording/data capturing when the trigger conditions for all selected waveforms are met.

**OR**

This lets you start recording/data capturing when the trigger conditions for any of the selected waveforms are met.

**Source Channels**

This lets you select the channels for triggering.

**Slope (for internal trigger)**

This lets you select either a leading-edge, a trailing-edge, a low-level or a high-level trigger.

**Trigger Level (for internal trigger)**

This lets you select the threshold level for low-level, high-level, leading-edge and trailing-edge triggering as either zero or a percentage between -100 and 100.



## 1.2.4 Other Useful Functions

### Floppy Disk Functions

You can store captured data, waveform data on the screen and setting parameters to a floppy disk.

### Communication Interface (optional)

You can transfer measurement data and setting parameters to a personal computer over an optional GP-IB or RS-232-C interface. You can also control recording and data capture, and enter setting parameters from a personal computer using these interfaces. For details, refer to IM 781011-11E.

### Linear Scaling

When measuring physical quantities such as distortion, vibration, pressure, displacement, acceleration, etc., this function enables chart printouts or displays to use a scale which is appropriate for the measurement subject.

As shown in the figure below, two random scale values (SP1, SP2) which correspond to two measurement voltage/temperature values (VP1, VP2) are designated.

The scale conversion method ( $y=ax+b$ ) is determined according to these four settings.

The upper and lower limits of the full scale can be set at the measurement range settings.

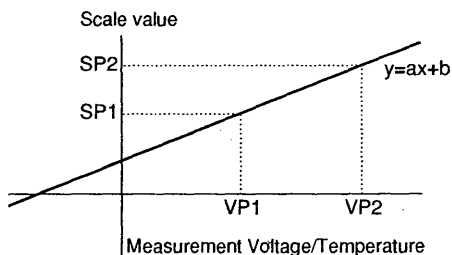

### Copying Setting Parameters and Annotations

When you have a number of input channels for which you want identical control settings, you can save time by selecting the settings for one channel and then just copying them to other channels. Also, annotations and linear scaling settings will be copied as well.

### Hard Copy

You can print out a copy of the current display onto the chart.

### Printing Setups

You can print out a list of the current setup onto the chart whenever you want to keep a record of your measurement conditions. For an example of this printout, see appendix B.

### External Input/Output

The following signals can be in/output at the external input/output terminal at the rear panel.

#### External Trigger Output

You can use this output to trigger other equipments, such as other OR1400 recorders connected in parallel.

#### External Trigger Input

You can use this input signal to have your recorder externally triggered, e.g. when connecting up to 4 OR1400 recorders in parallel.

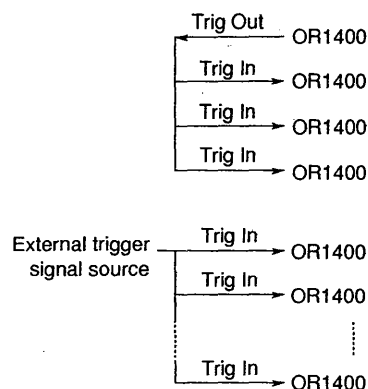

### Start/Stop of Recording, Data Capturing or Printing Messages

You can use this input signal to start and stop real-time recording, data capturing or printing messages.

### External Chart Speed Control

You can use this input signal to change the chart speed.

### External Event Input

You can use this input signal to have an event mark printed.

### External Sampling Clock

You can use this input signal to input an external sampling clock for use during data capture.

### Switching the Language

The language used in the display can be selected from English, German, French or Japanese.

# 1.3 Nomenclature

## 1.3.1 Front Panel

### LCD display

Displays the measurement input as analog waveforms or numeric values. It also displays setting parameters and any error messages.

### Panel keys

Are used to select and enter setting parameters on the display and to control the operation of the recorder. See 1.3.2 for a more detailed explanation.

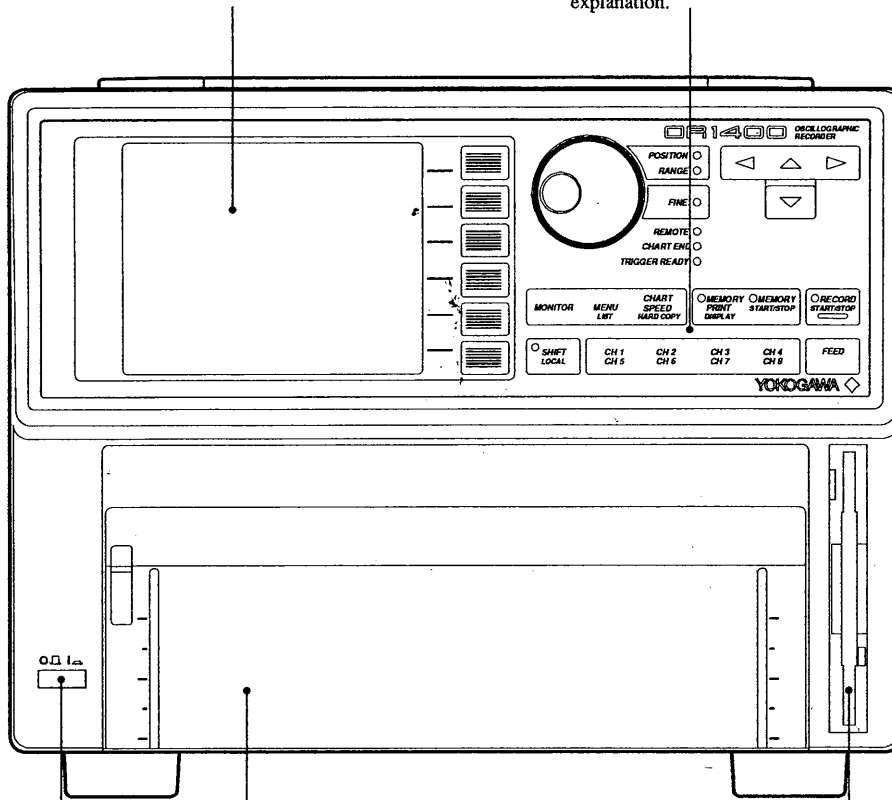

**Power switch**  
Used to turn the power on and off.

**Chart paper cover**  
Contains the chart paper. See 2.6 for loading the paper.

**Floppy disk drive**  
Used to load / save setting parameters / measurement data to and from the floppy disk.

## 1.3.2 Key Panel

### Soft keys

You press these keys to select the corresponding setting indicated in the soft key menu on the screen.

### Rotary Knob

You use the rotary knob for measurement range settings and position settings. You also use this knob to select characters when entering character strings. See 3.3.2 and 3.2.

### Position/Range key

You press this part of the key to select between range and position setting. When position is selected, this indicator will light. See 3.3.2.

### Fine key

You press this key to select between fine and coarse adjustments. In combination with the range setting, you use this key to set the full-scale values. When FINE is selected, the indicator will light. See 3.3.2.

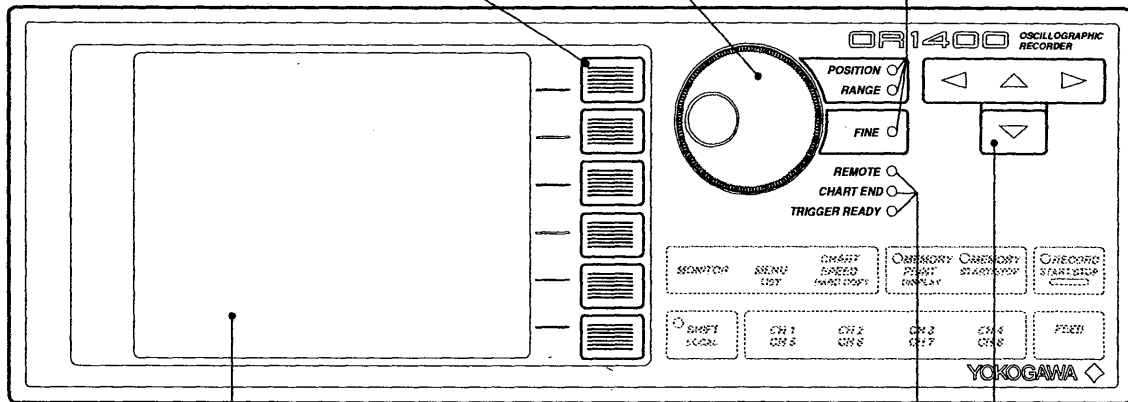

### LCD display

This is used to display the measurement input as analog waveforms or numeric values. It also displays control settings and any error messages.

### Remote Indicator

This indicator lights when the recorder is in the remote control mode.

### Chart End Indicator

This indicator lights when the recorder has run out of paper. See 2.6.

### Trigger Ready Indicator

This indicator lights when the trigger conditions are set. It turns off when the trigger fires.

### Cursor keys

You press these keys to move the cursor on the screen in the direction as indicated by the keys.

### LCD Contrast Controller

When you press the MENU-key, operating the rotary knob results in changing the contrast of the display.

#1	Trace (T-Y)	# 1
#2	Print format	# 2
#3	Memory format	# 3
#4	Trigger	# 4
#5	Load / Save	# 5
#6	Flexible zone adjust	
#7	Retrieve calculation	
#8	Comment	
#9	System	
#10	Logic	
	LCD contrast	NEXT

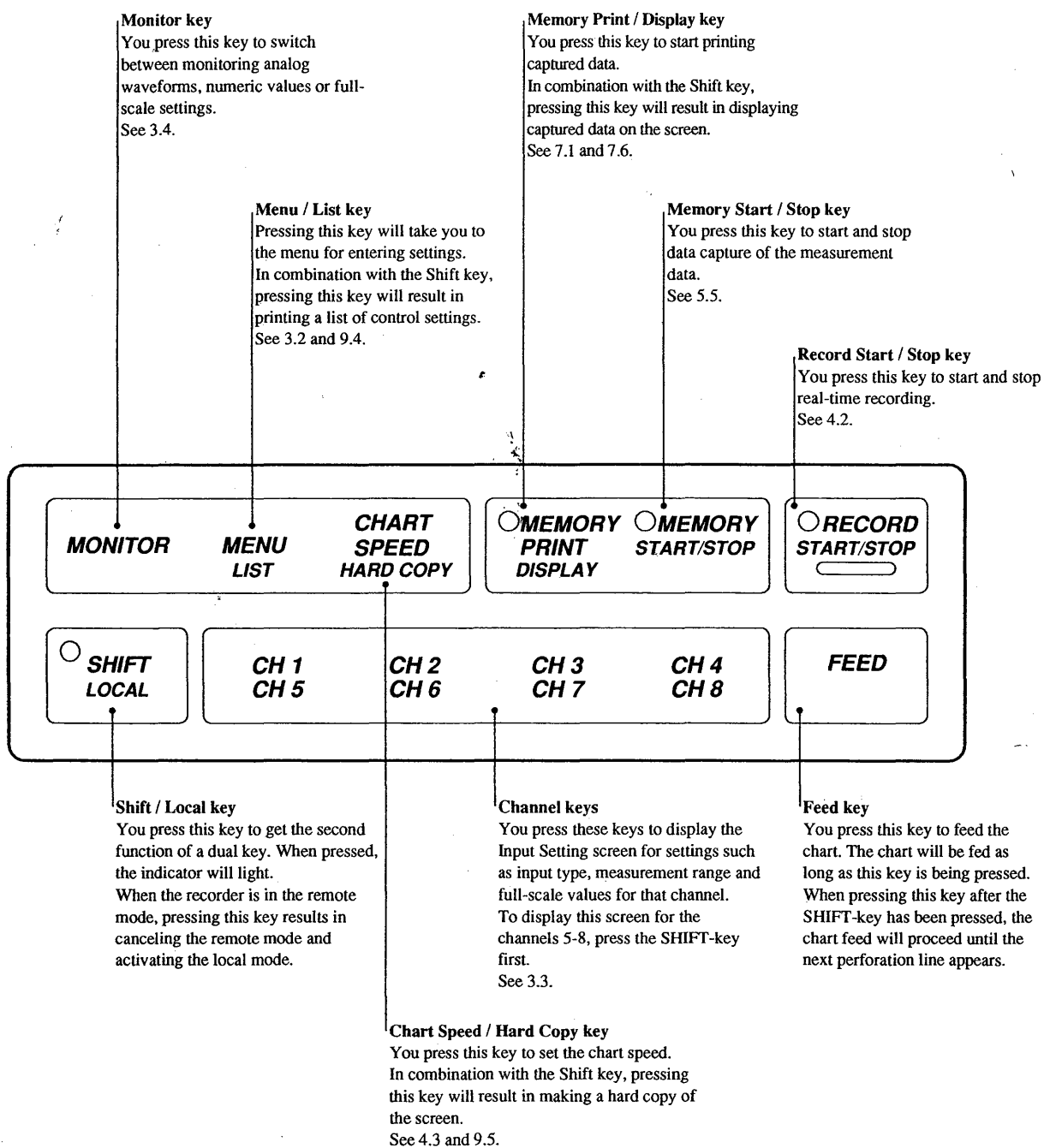

### 1.3.3 Rear Panel

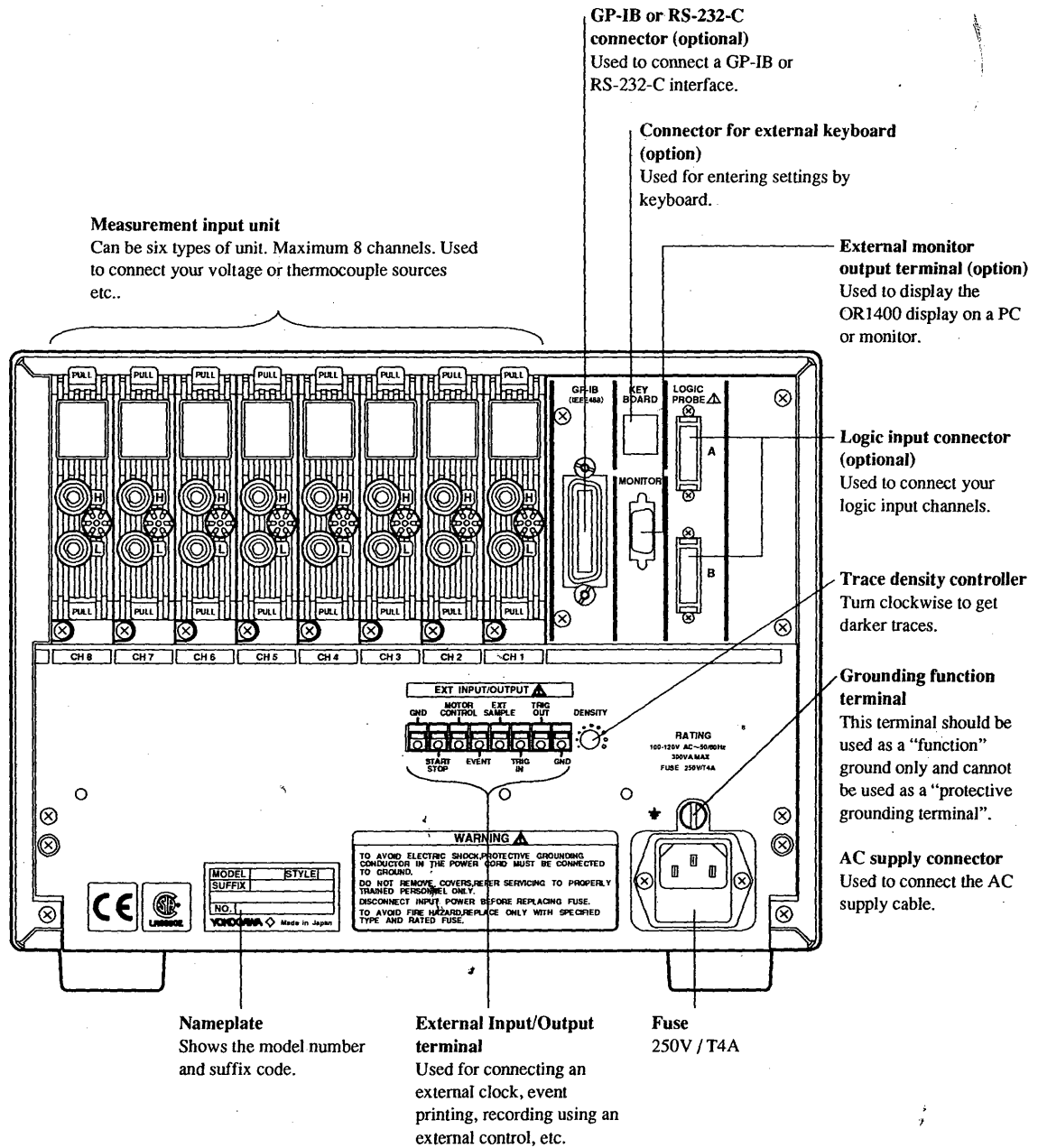

**NOTE**  
This figure shows 8 connected universal input units.

# 1.4 Operation Flow Chart

This section describes an operation flow chart, which makes it easy to keep an overview of the settings you are about to do.

The OR1400 mainly performs four functions:

- Real-time recording
- Data capture
- Printing captured data
- Displaying captured data

The flow chart below shows you the operational flow and where to find information. Reference page numbers are printed in bold script.

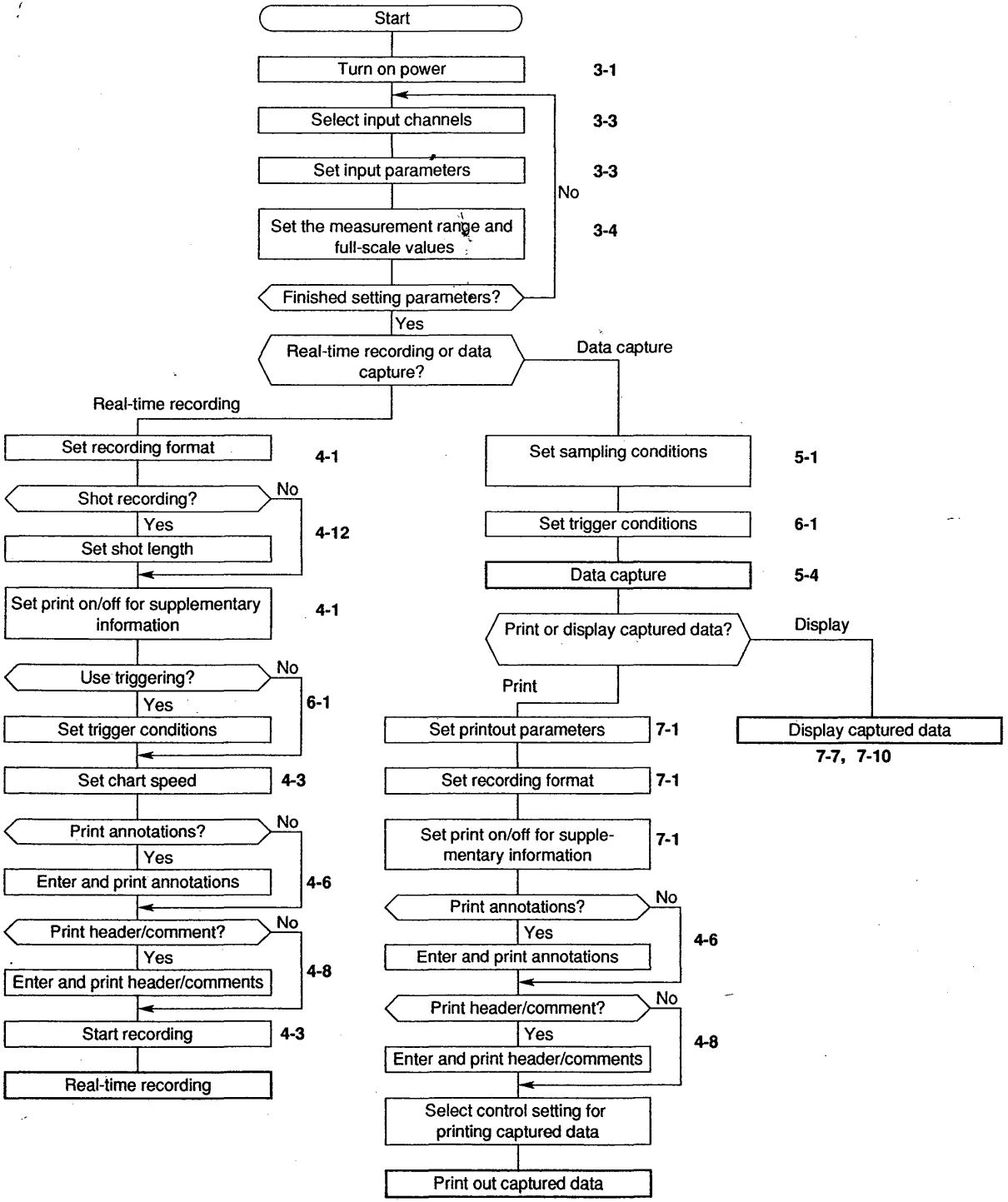

The numbers in bold script show the page numbers.

# Before Operation

This chapter describes the preparations to be made before you can operate the OR1400 recorder. Please read this chapter carefully before installing and using your recorder.

## 2.1 Handling Precautions

### 2.1.1 Handling Precautions for the Recorder

#### Input Terminals

Do not bring any objects charged with static electricity near the input terminals. This might cause malfunction.

Do not jar the input terminals. When a shock is given to a terminal, this might be converted into electric noise and input.

#### Input Cables

In order not to pick up any induction noise from the power cable, we recommend to keep the input and output cables as far away as possible from the power cord.

#### Ventilation

Always keep the ventilating louvers and cooling fan outlet unobstructed to prevent internal heat buildup.

#### Display

Remove the protective film covering the LCD display only after having set up the recorder. The LCD display lasts for about 20,000 operating hours. When the LCD display is used for more than this, the brightness of the display may become weaker. In that case the display needs to be replaced. Contact your sales representative.

#### Cleaning

Do not use volatile chemicals when cleaning the case, operating the panel or other portions of the recorder. Do not allow rubber or vinyl to remain in contact with the recorder for extended periods of time. Always use a dry, soft cloth for cleaning.

#### When Moving the Recorder

Ensure that power cord and input cables are disconnected. When carrying the recorder, use the handle. When the recorder is being moved while the chart is loaded, it is possible that the chart setting may be disturbed. Therefore, when having moved the recorder with the chart loaded, make sure to adjust the chart loading, following the instructions in 2.6.

#### After Use

Ensure that the power is unplugged.

#### In Case of Malfunction

Never continue to use the recorder if there are any symptoms of malfunction such as unusual sounds, smell, or smoke coming from the recorder. Immediately disconnect the power supply and stop further use of the instrument. If such abnormal symptoms occur, contact your sales representative.

### 2.1.2 Handling Precautions for the Printer Head

#### Printer Head's Temperature

The printing load will automatically be reduced if the printer head's temperature exceeds a prescribed level, to protect the head. Therefore there may be cases when the print intensity becomes abruptly fainter during printing. The print intensity will return to its original state when the printer head's temperature is reduced.

#### Soiled Printer Head

The printer head may become soiled over long periods of operation, causing the printout to become blurred in some places. In that case, clean the head as described in 11.4.

#### Printer Head's Life

The life of the printer head is approximately 30km (approx. 750 chart stacks). If this period is exceeded, the quality of the printing may suffer. To replace the printer head, contact your nearest sales representative.

#### Printer Head/Chart Feed Malfunctions

Printing and chart feed may become stuck when the instrument is moved from a cold and dry place to a warm and humid place, or as the result of quick change in the room temperature.

In this case, leave the instrument in the new environment for at least one hour before usage.

## 2.2 Installing the Recorder

The installation site of the OR1400 should meet the following conditions as close as possible:

- The recorder should be placed in a well ventilated area. Always keep the ventilating louvers and cooling fan outlet unobstructed to prevent internal heat buildup. The required space to prevent internal overheating is as indicated below.

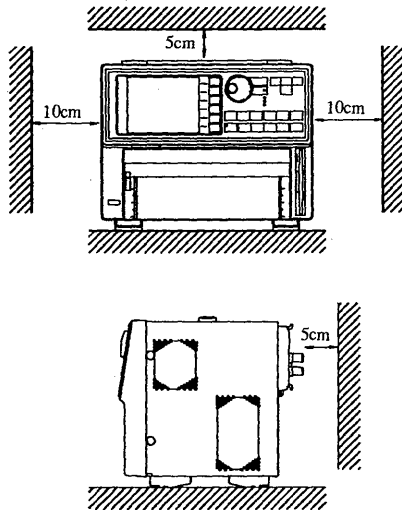

- The recorder will be adversely affected if the unit is exposed to direct sunlight or installed near a heater. Choose a location near room temperature (23°C) with minimal temperature fluctuations. Relative humidity should be 30 to 80% with no condensation. When the relative humidity is 30% or lower, protect the recorder from static electricity buildup by using a grounded discharge mat. When moving the unit from a dry, cool environment to a warm, humid environment, allow the recorder at least one hour to acclimatize.
- The recorder must be installed horizontally. However, the maximum permissible inclination from front to rear is  $\pm 5^\circ$ . Angles greater than this can impede proper recording.
- To expose the recorder to soot, steam, moisture, corrosive gases etc. will adversely affect it.
- To use the recorder within strong electro-magnetic fields may cause malfunction. Please avoid installing near electro-magnetic objects.
- To install the recorder in a location susceptible to mechanical vibrations will adversely affect the mechanical parts and the quality of recording. Please choose an installation site characterized by minimal mechanical vibrations.
- Install the recorder at a location in accordance with category II (CAT II) of IEC1010-1 or CSA1010.1.
- Please do not install the recorder at altitudes above 2000m above sea level.
- This recorder is a POLLUTION DEGREE 2 instrument.
- Installation Site  
To use the OR1400 within domestic establishments and within establishments directly connected to a low voltage power supply network which supplies buildings used for domestic purposes may cause malfunction of other equipments. Please avoid using in domestic environment.



## 2.3 Installing the Input Unit

This section describes how to (dis)connect the input unit used for measurements.

### Type of Input Unit

Two types of input units are available.

- voltage input unit (parts no. : 783051)
- universal input unit (parts no. : 783052)
- RMS converter unit (part no. : 783053)
- Strain input unit (part no. : 783054)
- Frequency input unit (part no. : 783055)
- Power line freq. input unit (part no. : 783056)

### Caution when Installing the Input Unit

After having installed the input unit, turning the power ON will result in initializing the settings. In case you want to keep your settings after the installation, save your settings beforehand to internal RAM or FD.

#### CAUTION

- When installing the input unit, make sure that no measurement signals are connected to the input terminals.
- Make sure to apply the input covers to the channels which are not installed.

### Installation Procedure

- 1 Verify that the power switch on the front panel is turned OFF.
- 2 Remove the screws of the input covers of the to be used channels on the rear panel using a plus-driver and while pressing the upper latch a little downwards, remove the cover.
- 3 Insert the input unit into the connector of the main unit properly.
- 4 Fasten the screw.

Upper latch

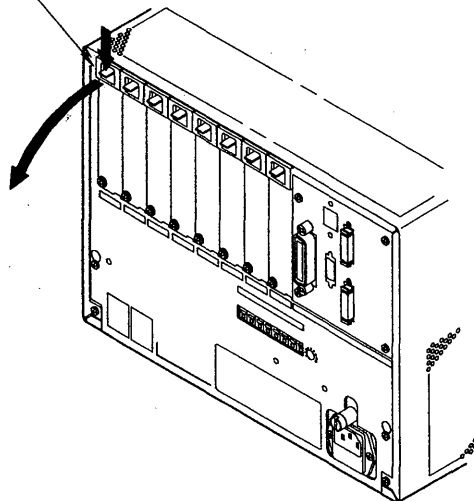

### Removing Procedure

- 1 Verify that the power switch on the front panel is turned OFF.
- 2 Remove the screws of the input units to be removed using a plus-driver.
- 3 While pressing the upper latch a little downwards, and holding the latches with both hands, remove the unit by pulling it slightly forwards.

Upper latch

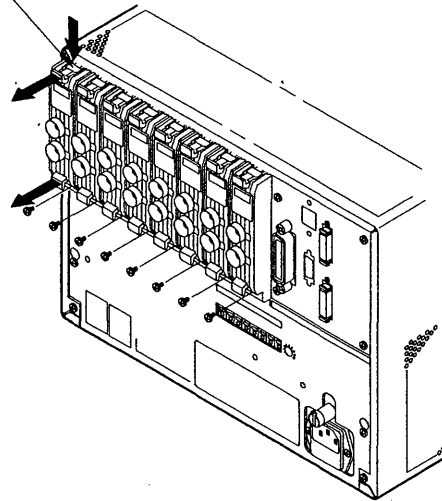

## 2.4 Mounting the Rack

In case the main unit will be rack mounted, use the separate rack mount kit.

### Type of Rack Mount Unit

Two types are available.

- for JIS : 781931
- for ANSI : 781932

#### CAUTION

The OR1400 is equipped with ventilation holes and a fan. When mounting the OR1400 in a rack, make sure to comply with the required spaces as described in 2.2.

### Applying

- 1 Remove the seals covering the holes for rack mounting on the left and right side of the OR1400 main unit.
- 2 Apply the rack mount kit.
- 3 Insert the OR1400 into the rack.

### Rack Mount Measurements

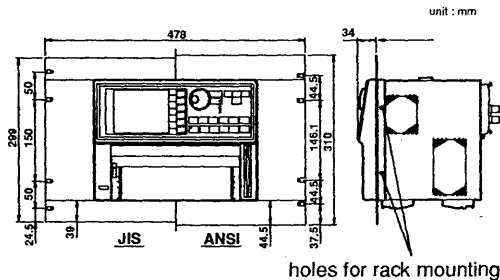

## 2.5 Connecting the Power Cord and Signal Cables

### 2.5.1 Connecting the Power Cord

- 1 Make sure the power switch at the rear panel is turned OFF.
- 2 Plug the female end of the power cord into the socket on the rear panel. Refer to the figure below.
- 3 Plug the male end of the power cord into a power outlet which meets the specifications in the following table. For the power outlet, use a 3-pin power outlet with grounding terminal.

Rated Power Supply Voltage	100 to 120 / 200 to 240 V AC
Permissible Supply Voltage Range	90 to 132 / 180 to 250 V AC
Rated Supply Voltage Frequency	50 / 60 Hz
Permissible Supply Voltage Frequency Range	48 to 63 Hz
Maximum Power Consumption (with chart operation)	300 VA (100V), 360 VA (200V)

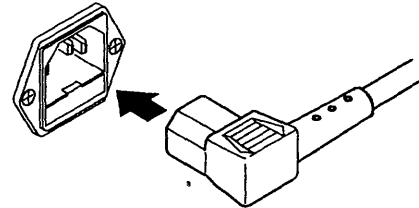

#### WARNING

Verify whether your power outlet supplies 100V or 200V voltage. Only use power supplies that comply with the rated voltages. Always make sure to use grounded power cords. Do not use non-grounded extension cords or other measures that defeat the protective grounding.

#### NOTE

To prevent an emission of electromagnetic disturbances, separate the power cord from the other wires as far as possible.

## 2.5.2 Connecting Measurement Inputs

Connect the signal cables only to the measurement input terminals of the input unit located on the rear panel. The number of input terminals differs by the number of installed input units.

In case of the universal input unit and frequency input unit, the input terminals can be of the binding post type, or of the bananaclip type.

In case of the voltage input unit, RMS converter unit and power line frequency input unit, the input terminals are of the bananaclip type.

In case of the strain input unit, the input terminals are 8 pin DIN connectors.

Connect the input cable as shown below.

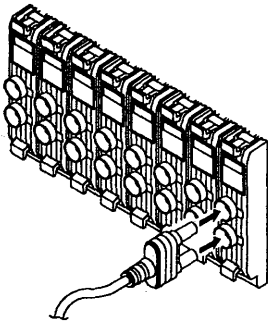

Voltage input unit (parts no. : 783051),  
RMS converter unit (parts no. : 783053)  
or power line freq. input unit (parts no. :  
783056) 8 channels installed

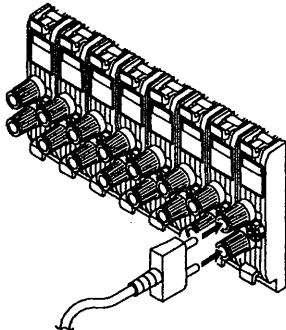

Universal input unit (parts no. : 783052),  
or frequency input unit (parts no. : 783055)  
8 channels installed

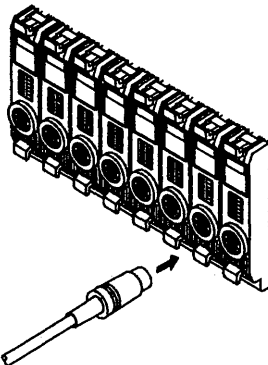

Strain input unit (parts no. : 783054),  
8 channels installed

### WARNING

- When applying input to the input terminals of the voltage input unit, always make sure to use the accessory measurement input cables.
- Never allow the floating voltage to exceed the following values :  
voltage input unit, RMS converter unit and power line freq. input unit : 350VDC + AC peak  
universal input unit, strain input unit and frequency input unit : 30Vrms or 60VDC  
If voltages which exceed these ratings are applied to the input terminal, the input circuit could be damaged.

### CAUTION

- The input impedance is as shown below. The signal source resistance (including input signal line resistance) should be less than 500Ω. If the signal source resistance exceeds 500Ω, a bias current of approximately 2nA will be produced. Beware of measurement errors.

Note that the impedance will change under the following conditions due to the protection circuit.

- voltage input unit : approx. 1MΩ  
when the input voltage is more than 20V, the range 100mV to 5V, the input impedance becomes approx. 500kΩ.
- universal input unit : approx. 1MΩ  
when the input voltage is more than 10V, the range TC or 50mV to 2V, the input impedance becomes approx. 10kΩ.
- RMS converter unit : approx. 1MΩ
- Strain input unit  
Power on : more than 10MΩ ( $V_{in} < 10V$ )  
Power off : more than 1kΩ (input impedance depends on  $V_{in}$ )
- Frequency input unit : approx. 100kΩ
- Power line freq. input unit : approx. 1MΩ
- Never allow the maximum permissible measurement input voltage (potential difference between measurement input terminals) to exceed the following values:

voltage input unit, RMS converter unit or power line freq. input unit : 350VDC + ACpeak  
universal input unit, strain input unit or frequency input unit : 30Vrms or 60VDC.  
Voltages exceeding this level could damage the input circuit.

- When connecting a thermocouple, be sure that the thermocouple wire is connected directly to the measurement input terminal. Do not use a thermocouple with a tip type terminal having a high heat capacity, as this can cause temperature changes at the terminal area, resulting in reference junction compensation errors.

### NOTES

- Keep the signal cables as far as possible from the power cord.
- To prevent an emission of electromagnetic disturbances, separate the Measurement input and Logic input wires from the other wires at least 0.1m. Over 0.5m is recommended.

### 2.5.3 Connecting the Gage (for the strain input unit only)

This section describes how to connect the gage of the strain input unit.

#### Dipswitch

The dipswitches of the strain input unit relate to the following methods of measurement.

- 1/4 bridge
- 3-wire 1/4 bridge
- 1/2 bridge (neighbor)
- 1/2 bridge (opposite)
- Full bridge
- DC mode

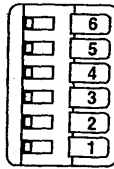

Dipswitch

#### DIN connector

The DIN connector looks as follows.

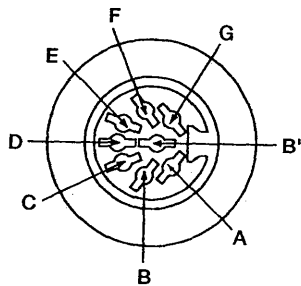

#### Wiring

- 1/4 bridge

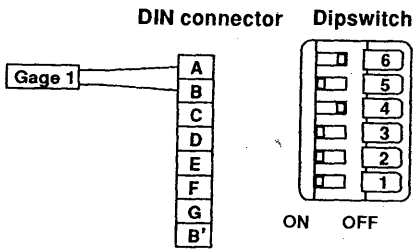

- 3-wire 1/4 bridge

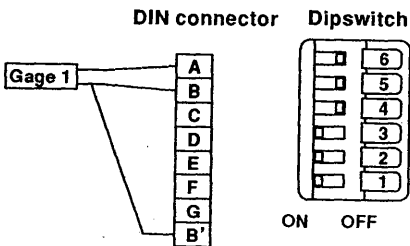

- 1/2 bridge (neighbor)

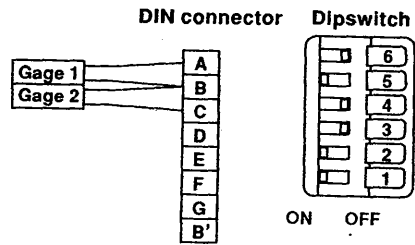

- 1/2 bridge (opposite)

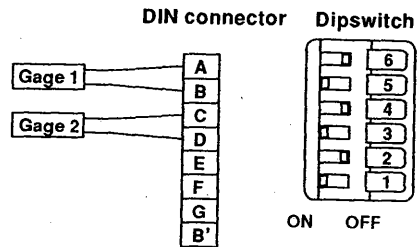

- Full bridge can be used with a strain gage converter (including an external bridge box)

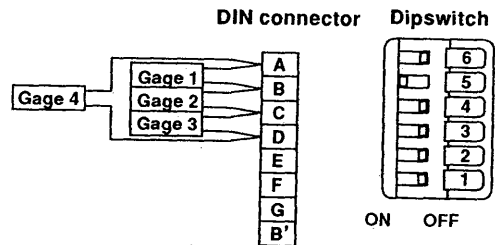

- DC mode

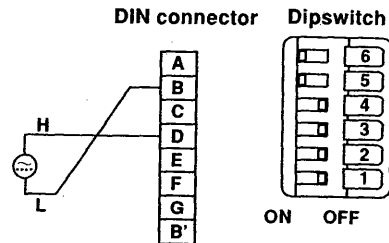

#### NOTE

Make sure to use shielded wires for strain measurements in order to eliminate the effect of external noise.

Apply a shield to the shell of the DIN connector or to the E-terminal.

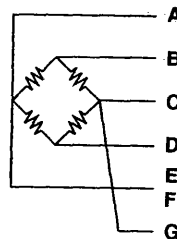

## 2.5.4 Connecting External I/O Control Signals

You can connect external signals to the "EXT Input / Output" terminals located on the rear panel.

External equipment must comply with IEC1010-1 or CSA1010.1.

The terminal looks as follows.

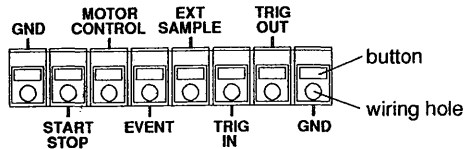

### CAUTION

The maximum input voltage to the external input terminal must not exceed the -5V to 5V range. If voltages which exceed these values are applied, the terminal might be damaged.

### Recording Start/Stop, Data Capturing Start/Stop and Printing Messages (Start/stop)

This is the external start/stop signal you can use to control real-time recording, data capturing and printing out messages by an external source. This input supports TTL-level and contact (open/close) signals. See 9.6.

### External Chart Speed Control (Motor Control)

This is the TTL-level signal you can use to control the chart speed externally. See 9.7.

### External Event Input (Event)

This is the TTL-level signal you can use to enter an event marker. See 9.8.

### External Sampling Clock (Ext sample)

This is the TTL-level, external sampling clock signal input. See 9.9.

### External Trigger Input (Trig in)

This is the TTL-level, trigger signal input you can use to trigger recording. See 6.2. This is also the TTL-level, trigger signal input to be used when you connect other OR1400 recorders. See 9.10.

### External Trigger Output (Trig out)

This is the TTL-level, trigger signal output you use to connect other OR1400 recorders. See 9.10.

### Wires

recommended wire : solid wire  $\phi 1.0$  (AWG18), cross sectional area  $0.75\text{mm}^2$   
usable wires : solid wire  $\phi 0.4$  to  $1.0$  (AWG26 to 18), cross sectional area  $0.3$  to  $0.75\text{mm}^2$  (AWG22 to 20), element wire at least  $\phi 0.18$ .  
bare wire :  $10\text{mm}$

### Wiring Procedure

- 1 Verify that the power switch on the front panel is turned OFF.
- 2 Insert the wire into the appropriate EXT INPUT/OUTPUT terminal at the rear panel. To remove the wire, press the button above the wiring hole using a minus screwdriver, and pull the wire slightly.
- 3 Verify that the wire is fastened properly.
- 4 Turn ON the power of the OR1400.

### NOTES

- Do not use signal cables exceeding 3m in length as they can pick up noise that can disrupt recorder operation.
- Keep the signal cables as far as possible from the power cord.
- To prevent an emission of electromagnetic disturbances, separate the External I/O wires from the power supply and Measurement input and Logic input wires at least 0.1m. Over 0.5m is recommended.

## 2.5.5 Connecting Logic Input Signals (option)

Logic probes can be connected to the OR1400 input connectors.

Since each probe has a TTL level input/contact input selector switch, wide-ranging measurement is available from electronic circuit to relay operation timing.

Logic input consists of channels A and B. Each channel consists of 8 bits, i.e. a total of 16 bits can be input.

The accessory logic probe is used for connection with the measurement points. For connection with the measurement points, you can select between the alligator-clip cable and IC-clip cable.

### Component Names

- |                                    |   |
|------------------------------------|---|
| 1 Input selector switch            | Used to select the input being either TTL level or contact input (CONT).  |
| 2 Connection lead (alligator clip) | Connected mainly to the contact circuit and consisting of eight signal lines (red) and eight ground lines (black).  |
| 3 Connection lead (IC clip)        | Connected mainly to the electronic circuit and consisting of eight signal lines (red) and two ground lines (black). |
| 4 26-Pin connector                 | Connected to the OR1400 logic input connector.  |

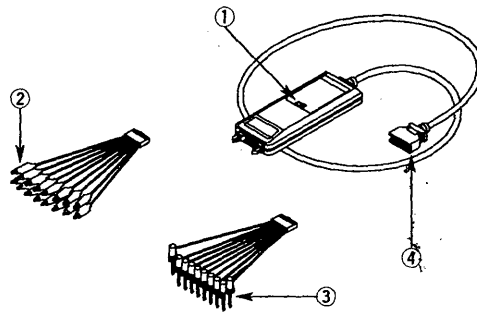

### Operating Procedure

- 1 Connect the connection lead (IC or alligator clip) to the logic probe main unit.
- 2 Set the input selector switch. In case of TTL level input, a voltage higher than the threshold level of approx. 1.4V sets logic to "1"; In case of contact input, shorting signal lines and ground lines sets logic to "1".
- 3 Turn the power switch of the OR1400 off.
- 4 Connect the 26-pin connector to the OR1400 logic input connector.
- 5 Turn the power switch of the OP1400 on.
- 6 Connect individual lead clips to the measurement points.

### Specifications (when connected to the OR1400)

Input type	Common ground within the same probe Floating between recorder and probe
Number of input bits	8
Allowable input range	±35V
Input impedance	10kΩ or more
Threshold level	Approx. +1.4V
Input method	TTL level or contact input (switching type)
Withstanding voltage	Between logic probe and case: 500VDC for one minute
Insulation resistance	Between logic probe and case: 10MΩ or more at 500VDC.

### WARNING

Applying a floating voltage which exceeds 30 Vrms or 60 VDC may cause electrical shocks.

### CAUTION

Do not fail to confirm the selector switch setting before connection.

Eight input lines are grounded in common within one probe. Therefore, to avoid damaging the logic probe or any connected appliances never use contact inputs which have different common voltages.

When the 26-pin connector is connected to or removed from the OR1400 logic input connector, the OR1400 power switch must be turned off. Never attempt to modify (by extension, etc.) the connection lead.

The allowable input range (±35V, including common voltage) must be strictly observed. Otherwise, the logic probe and OR1400 main unit may be damaged.

### NOTES

- If the logic probe is not connected to the OR1400, the waveform becomes "1".
- To prevent an emission of electromagnetic disturbances, separate the Measurement input and Logic input wires from the other wires at least 0.1m. Over 0.5m is recommended.

## 2.5.6 External Monitor Output (option)

This section explains how to display the OR1400 screen on a personal computer or monitor by RGB output and how to connect this interface.

### CAUTION

- Always make sure that the power of both the OR1400 and the monitor is OFF prior to connecting.
- Do not short circuit the monitor terminal, or input any external voltage. This will damage the OR1400.

### Which Monitors

VGA monitors or multisync monitors on which VGA can be displayed, can be used.

### Specifications

PinNo.	Signal	Specifications
1	red	0.7Vp-p
2	green	0.7Vp-p
3	blue	0.7Vp-p
4	GND	
5	GND	
6	GND	
7	GND	
8	GND	
9	—	
10	GND	
11	—	
12	—	
13	horizontal	33.33kHz, TTLlevel <input type="checkbox"/>
14	vertical	60.168Hz, TTLlevel <input type="checkbox"/>
15	—	

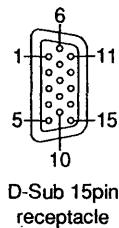

### Connecting the Interface

Turn the OR1400 and the monitor OFF.

- 1 Connect the analog RGB cable to the Monitor terminal at the rear panel of the OR1400.
- 2 Turn the power of the OR1400 ON.
- 3 Turn the power of the monitor ON. The monitor will display the OR1400's screen.

### NOTES

- An ordinary RGB video signal is always being output from the Monitor terminal.
- If you place the OR1400 or any other instrument close to the monitor, display disturbances might occur.
- Depending on the type of monitor, the edges of the screen might be lacking.
- To prevent an emission of electromagnetic disturbances, separate the External Monitor wires from the power supply and Measurement input and Logic input wires at least 0.1m. Over 0.5m is recommended.

## 2.5.7 The External Keyboard (option)

This section explains how to use a keyboard for setting and operating the recorder.

### Which Keyboard

IBM/PS2 compatible keyboards can be used.

### Settings which Cannot be Done from the External Keyboard

- Setting the measurement range and full scale values
- Setting the suppression voltage value
- Setting the adjustable chart speed (V1, V2) in case of real-time recording.

### Which Keys Can be Used

All keys in the shaded line in the figure below can be used. The others cannot be used.

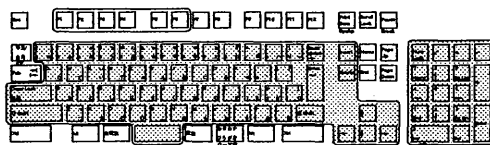

• The numerals will only be valid after having pressed the NumLock key first.

### Equivalent Key Functions

#### Displaying Screens

- Setting screen (MENU key) : Shift-key+F1-key
- Chart Speed setting screen (CHART SPEED key) : Shift-key+F2-key.

#### Moving the Cursor

- △ : ↑
- ▷ : →
- ◁ : ←
- ▽ : ↓

#### Selecting Soft Keys

Print format Mode : Analog Format : <input type="checkbox"/>	1 Zone 200mm ← F1
Grid intensity : Normal Grid type : 10mm fine Scale print : On Annotation : On Channel print : On [400mm] Header print : Time Flexible zone : Off	1 Zone 160mm ← F2
Shot recording : Off Tick / Event : 1 [sec]	2 Zone ← F3
	4 Zone ← F4
	8 Zone ← F5
	X - Y ← F6

### Other Key Board Keys

#### Enter-key

While "Enter" is being displayed at the soft key menu, pressing this key has the same result as if you pressed the corresponding soft key.

**Insert-key**

When entering characters, pressing this key will switch the mode between overwrite and insert, just as the soft key does.

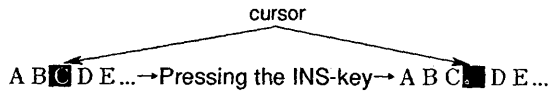

**Backspace-key**

When entering characters, pressing this key will move the cursor leftwards, just as the soft key does.

**Delete-key**

When entering characters, pressing this key will delete the character which the cursor indicates, just as the soft key does.

**Shift and Caps-key**

Pressing these keys while entering characters will switch between upper- and lower-case characters.

**NOTES**

- Even when using the external keyboard, panel key operation stays possible.
- Even in case of communication interface the panel key operation becomes disabled, external keyboard operation stays possible.

**Entering Characters and Numbers**

- You can enter characters at any screen by typing the character keys. However, the special characters and symbols which can be entered at the OR1400's screen cannot be entered using the keyboard or communication interface.
- Numbers can be entered by moving the cursor to the place you want to insert the number, and typing it. Note to press the NumLock first. Press the Enter-key and the setting is completed.

**Connecting the External Keyboard**

- 1 Turn OFF the power of the OR1400.
- 2 Connect the keyboard plug to the "Keyboard" connector located at the rear of the OR1400.
- 3 Turn the power of the OR1400 ON.

**NOTES**

- Make sure to switch the power of the OR1400 OFF before connecting or disconnecting the external keyboard. This is because the OR1400 only verifies whether the external keyboard is connected or not at power ON.
- To prevent an emission of electromagnetic disturbances, separate the External keyboard wires from the power supply and Measurement input and Logic input wires at least 0.1m. Over 0.5m is recommended.

**Operating Procedure**

**Selecting the type of keyboard**

- Selects the type of connected keyboard. The initial setting is "ASCII".
- 1 Press the MENU-key.
  - 2 Press the NEXT soft key and select "#9 System".
  - 3 Select "#5 Misc" using the soft key.
  - 4 Move the cursor to "Ext. Keyboard".
  - 5 Select "JIS" or "ASCII".

Misc		ASCII /
Alarm beep	On	
External ST/SP	Record	
Rec/Mem back up	Off	
Chart clock	Internal	JIS
Ext. key board	JIS	
Hard copy mode	TIFF	



## 2.5.8 Applying a Clamp Filter

Make sure to apply the clamp filter to the power cord to the logic probe input wire, and to the external key board cable, if you're using these options. This is to eliminate the electric emission.

- Type of clamp filter and cable of application

Clamp Filter	Cable of Application
Clamp filter (large) (A1179MN)	Power cord
	External keyboard cable
Clamp filter (small) (A1194MN)	Logic probe

- How to apply the clamp filter

In case of the big clamp filter, hold the clamp filter close to the plug of the power cord, or key board connector, turn the cable once around the clamp and close the clamp filter until it clicks.

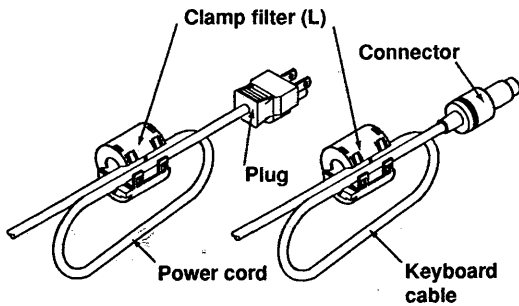

In case of the small filter, apply the clamp filter close to the connector of the logic probe cable.

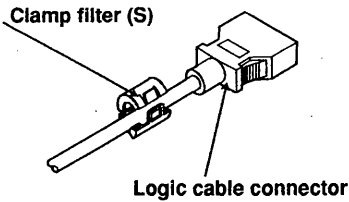

## 2.6 Loading the Chart

### Loading New Paper

- 1 Open the cover of the chart compartment by pulling the tab slightly forward.
- 2 Prepare the paper as shown in the figure below. Make sure the direction of the paper is correct.
- 3 Pull up the release lever which is located at the right.
- 4 Take the front of the paper, and insert it into the chart slot.  
Insert the chart paper until the paper comes out a few centimeters.
- 5 Match the perforation line to the guide, so that each fold of the paper will be located at the position of the guide. Don't worry about the slack of paper.
- 6 Press the release lever down again.
- 7 Close the chart compartment cover.
- 8 Turn ON the power of the OR1400 and press the FEED-key to confirm the paper feeds properly.

### NOTE

- The last meter of the chart is featured with a red band to notify you it is time to replace the chart.
- When the chart runs out, the chart end LED will become illuminated. Prepare a new chart.
- Press the SHIFT-key and then the FEED-key and the paper will be fed until the next perforation.

### Loading for the First Time

- 9 Fold (or cut) the corners of the chart paper and insert the leading edge into the slot. Then push the chart paper until it protrudes from the slot on the other side.
- 10 Align the edges of the chart paper with the flanges.
- 11 Secure the release lever in its original position.
- 12 Close the outer cover.
- 13 Turn the power ON, press the FEED-key and check that the paper moves smoothly.

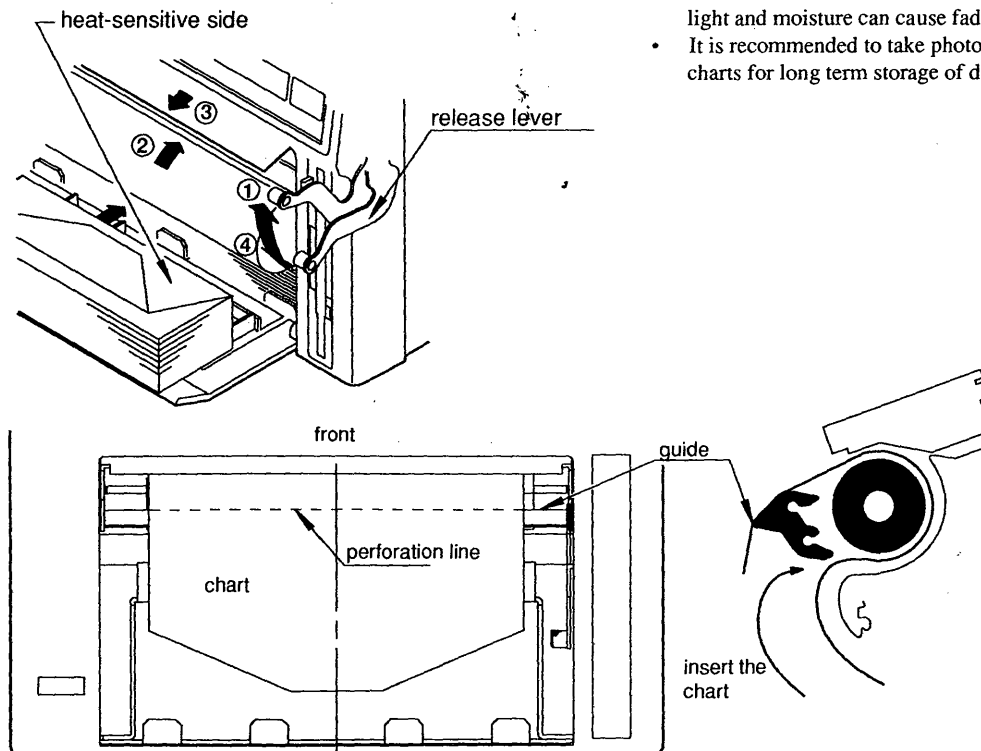

## 2.7 Handling Precautions for the Charts

### About Chart Paper

The chart paper is featured with perforation lines for easy cutting of the chart. Note that the recording on the perforation line might be weak.

### Storing Chart Paper

The used thermal paper changes color at approximately 70°C. Its thermal properties are also affected by moisture and light. Accordingly, you should take the following precautions.

- Store unused chart paper in a cool, dry, dark place.
- After breaking the seal, use the chart paper quickly.
- Prolonged contact with the plastic films which contain plasticizer (vinyl chloride film, cellophane tape, etc.) can cause fading. Therefore, if the paper is to be stored in a holder, a polypropylene type holder should be used.
- When affixing the paper with glue, avoid glues which contain organic solvents such as alcohol and ether, etc. as these will cause discoloration.

### Handling Chart Paper

- Make sure only to use chart paper provided by your sales representative. If other paper is being used, a paper jam might occur.
- Dry your hands before handling the paper to avoid perspiration from fingers, as this can cause smudging.
- Do not rub the surface with hard objects to avoid heat generated from friction, as this can cause discoloration.
- Avoid contact with chemicals, oils and other substances, as these can cause discoloration.

### Storing Recorded Charts

- Store recorded charts in a cool, dry, dark place as heat, light and moisture can cause fading.
- It is recommended to take photocopies of the original charts for long term storage of data.

## 2.8 Using the Chart Tray (option)

Install the chart tray as follows:

- 1 Fasten the bracket to the bottom of the OR1400 by means of the two screws.  
Make sure that the big opening of the bracket is facing the front side.
- 2 Insert the tray into the opening of the bracket.
- 3 As shown in the figure on the right, hang the tray inside the bracket so that the back of the tray is held by the bracket.  
Adjust the bracket to the center of the opening.

### NOTE

The Z-fold chart may not fold properly at high chart speeds.

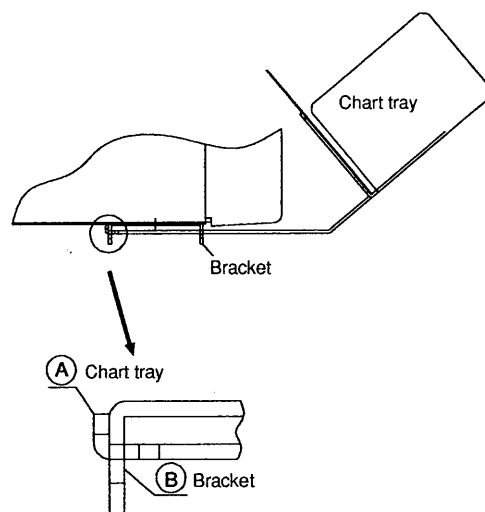
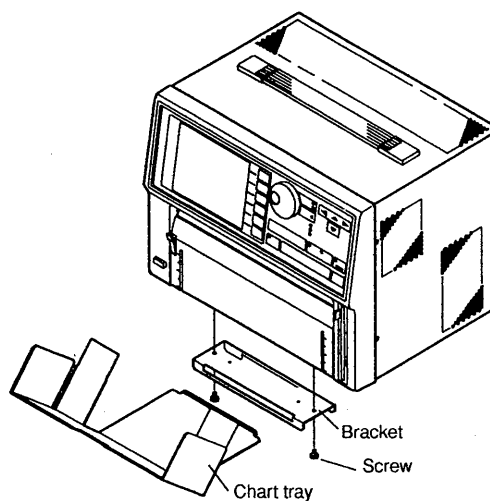

# Basic Operation

This chapter describes some of the basic operations you need to be familiar with before you start real-time recording or data capture.

## 3.1 Switching the Recorder ON/OFF

### Before Switching the Recorder ON

Set up the recorder as described in section 2.2. Then connect the power cord and signal cables as described in 2.3 and 2.5. Confirm that your power supply specifications are within the ranges shown below.

Rated Power Supply Voltage	100 to 120 / 200 to 240 V AC
Permissible Supply Voltage Range	90 to 132 / 180 to 250 V AC
Rated Supply Voltage Frequency	50 / 60 Hz
Permissible Supply Voltage Frequency Range	48 to 63 Hz
Maximum Power Consumption (with chart operation)	300 VA (100V), 360 VA (200V)

### Location of the Power Switch

You will find the power switch in the lower left hand corner of the front panel.

### Power Switch Operation

The power switch is of the push-button type. Pressing it will turn the power ON and OFF alternately.

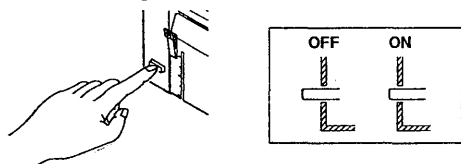

When you turn the power ON, initialization begins and the initialization screen will be shown. During initialization you cannot use the front panel keys. After initialization, the monitor screen will appear. After turning ON the power and having set the input ranges, allow a warm-up time of at least 30 minutes.

### Backup

In case of a power failure or similar, the data are backed up as follows:

- The current recorder setup will be kept.
- Previously saved setups will be kept (see 9.12).
- Measurement data will not be kept.

### NOTE

When you turn the power OFF, wait approximately 10 seconds before switching it ON again. Turn the power switch OFF when the recorder is not used for hours.

## 3.2 How to Enter Settings

The user interface of the OR1400 is designed in a way that settings can be done easily and quickly.

### Getting into the Settings screen

Almost all of the settings can be entered by first pressing the MENU-key and then selecting the required settings using the soft keys, cursor keys and rotary knob.

The menu which initially appears depends on whether recording is in progress or not.

### When the MENU-key is pressed and recording is not in progress:

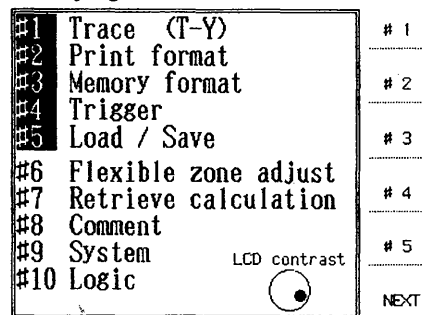

### When the MENU-key is pressed while recording is in progress:

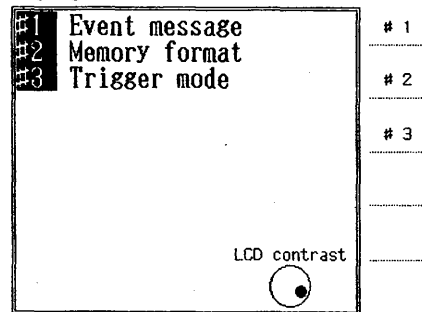

Returning to the initial setting screen can be done by pressing the MENU-key at any time.

For settings concerning the input, press the CH-key and the input setting screen will appear.

Input settings can be done except when data capturing or recording captured data is in progress.

The display looks as follows.

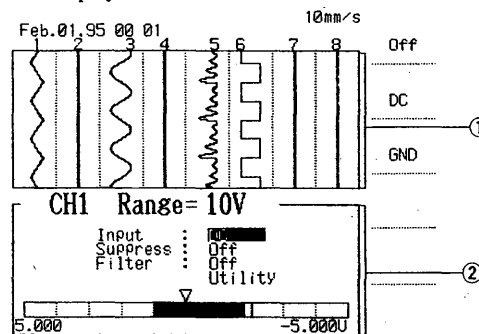

- ① monitor area
- ② setting area

### Selecting Settings

Settings can be entered using cursor keys, soft keys, and the rotary knob. Use them as follows.

#### Cursor keys

The cursor keys are useful to 'walk' to the desired setting within a particular screen. After entering a setting, usually the next setting will light, but you can easily move the cursor to another setting using the cursor keys.

#### Soft keys

In the right side of the display, the selectable items are written and they correspond to the soft keys located next to them. Pressing a soft key will change the setting accordingly.

#### Rotary knob

The rotary knob is mainly used to select numbers and characters. When the rotary knob should be used, a small rotary knob symbol will appear at the right side of the screen. Besides, the rotary knob should be used to set the range and position values.

#### Example

- ① Use the soft keys to select On or Off
- ② Use the rotary knob to select the required value
- ③ Use the cursor keys to select between Lower and Upper

### Entering Characters

The rotary knob is used to light a character which you want to input. When you have selected the required one by turning the knob, move to the next digit where you want to enter a character, using the cursor keys. Repeat this until all characters are set. You can switch between lower-case and upper-case characters by pressing the CAPS soft key. Changes are easy to handle by using the BS (back space), DEL (delete) and INS (insert) soft keys.

The "ALP" and "EUR" selection allows you to switch between the characters of the alphabet and other european languages.

For entering characters using the external keyboard option, refer to 2.5.6.

#### Example

### Entering Numeric Values

Numeric values should be entered using the rotary knob and cursor keys. Basically, the most right digit of a number will light. However, when you require big changes in numeric values, it is easier to move the cursor to another digit to adjust that digit.

#### Example

Assume you want to change the setting '123' to '010'. You can turn the rotary knob for a long time to go from 123 to 122 to 121 etc.. You can also adjust the 3 to 0 first; then move the cursor to the next digit and adjust 2 to 1; then move the cursor to the next digit and adjust 1 to 0.

For entering numeric values using the external keyboard option, refer to 2.5.6.

### 3.3 Input Signal Settings

This section describes how to set the input type & filter, the way to set the measurement range & full scale values, and the way to copy settings to an other channel.

#### 3.3.1 How to Set the Input Type and Filter

##### What You Should Know

###### Input Types

The following input types are available, depending on your model:

- **DC (DC-coupled voltage, except for frequency input units)**

With this input type you obtain the complete range of frequency components of your measurement input. The input impedance is approximately  $1\text{M}\Omega$ . The frequency response for this input type is shown below.

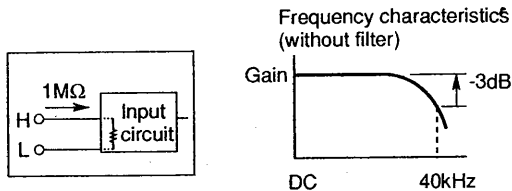

- **Thermocouple Input (for universal input unit only)**

Eleven types of thermocouple input are available when your instrument is equipped with the universal input unit.

type K	type R
type E	type S
type J	type B
type T	type N
type L	type W
type U	

- **RMS measurement (for RMS converter unit only)**

With this input type you can measure the effective value of AC voltage. The input impedance is approx.  $1\text{M}\Omega$ .

- **Strain measurement (for strain input unit only)**

With this input type you can measure strain inputs. The frequency response for this input type is shown below.

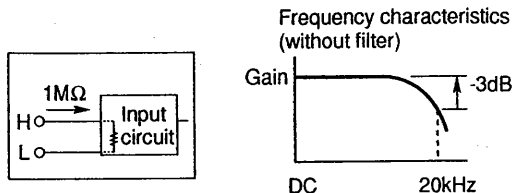

- **Ground (GND, except for frequency input units)**  
With this input type you position the ground level which can be useful for analog waveform recording.

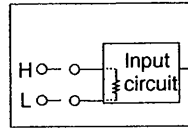

- **Logic Input (option)**  
Logic input channels are available. For settings, refer to 4.17.

- **Channel off (OFF)**  
When this setting is selected, recording and memory input will not occur for the specified channel, even if the corresponding input terminal is connected.

##### Input Filters

The following input filters are available, depending on your model:

- **In case of voltage input**  
You can select an input lowpass filter to remove the high-frequency components from your measurement input signal. Select "off" when no lowpass filtering is necessary.  
The following filters are available:  
voltage input unit RMS converter unit (for DC mode only) and strain input unit (for DC mode only)  
: 1kHz, 100Hz, 10Hz off  
universal input unit: 4kHz, 400Hz, 40Hz, 1.5Hz, off

- **In case of thermocouple input**  
You can select a 1.5Hz line filter to remove the 50 or 60Hz noise from your measurement input signal. Select "off" when no filtering is necessary.

- **In case of frequency input**  
When setting the measurement range, an input filter will be automatically assigned. Therefore, no such selection needs to be made.

##### Frequency Response of Voltage Input

You can record waveforms accurately up to 100Hz as shown below. You can also record waveform envelopes accurately up to 10kHz.

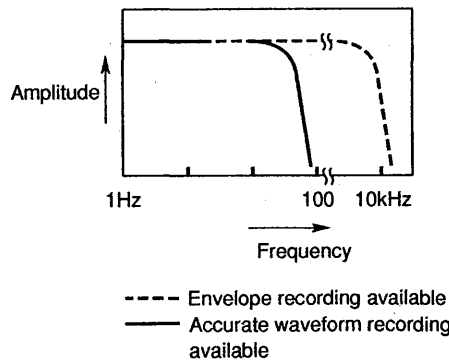

##### NOTES

- You can copy input type and filter settings to other channels. Refer to 3.3.7.
- If you change an input type (or measurement range) when memory has been partitioned, then any data currently in memory will be erased when you next start data capture, starting from the first block.

## Operating Procedure

### Measurement Channel: Setting the Input Type and Filter

- 1 Press the CH-key of the channel whose input type and filter you want to set. To display the channels 5-8, press the SHIFT-key first.
- 2 Select the required input type using the soft keys. If the required input type is already current, you may skip this step.
- 3 When required, move the cursor to the "Suppression" setting. Refer to 3.3.3 for details. Note that the suppression voltage can only be applied to channels of the voltage input unit.
- 4 When required, move the cursor to the "Filter" setting.
- 5 Select the required filter using the soft keys.
- 6 To set the input type and filter for an other channel, press the CH-key of that channel and repeat step 2 to 5. To copy the settings to other channels, refer to page 3-8.

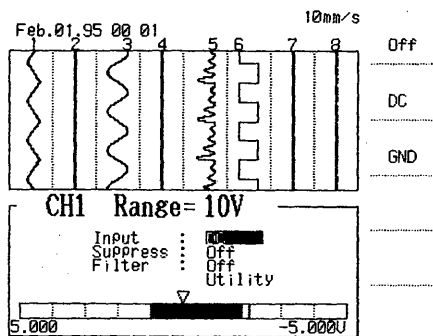

### NOTES

- In case you selected 'RMS' mode for the channels of the RMS converter unit, an input filter cannot be selected.
- When setting the measurement range, a filter will be automatically assigned and a selection will therefore not appear on the screen. For channels of the frequency input unit and input unit for power supply frequency.

Table 3.1 Measurement Ranges

#### DC-coupled voltage inputs:

Measurement Range	Actual Measurement Range	Initial Full-Scale Values	Maximum / Minimum Full-Scale Spans
500 V <sup>1</sup>	±350 V	-250 V to 250 V	1000 V <sup>3</sup> /50 V
200 V <sup>1</sup>	±200 V	-100 V to 100 V	400 V/20 V
100 V <sup>1</sup>	±100 V	-50 V to 50 V	200 V/10 V
50 V	±50 V	-25 V to 25 V	100 V/5 V
20 V	±20 V	-10 V to 10 V	40 V/2 V
10 V	±10 V	-5 V to 5 V	20 V/1 V
5 V	±5 V	-2.5 V to 2.5 V	10 V/0.5 V
2 V	±2 V	-1 V to 1 V	4 V/0.2 V
1 V	±1 V	-0.5 V to 0.5 V	2 V/0.1 V
500 mV	±500 mV	-250 mV to 250 mV	1000 mV/50 mV
200 mV	±200 mV	-100 mV to 100 mV	400 mV/20 mV
100 mV	±100 mV	-50 mV to 50 mV	200 mV/10 mV
50 mV <sup>2</sup>	±50 mV	-25 mV to 25 mV	100 mV/5 mV
20 mV <sup>4</sup>	±20 mV	-10 mV to 10 mV	40 mV/2 mV
10 mV <sup>4</sup>	±10 mV	-5 mV to 5 mV	20 mV/1 mV
5 mV <sup>4</sup>	±5 mV	-2.5 mV to 2.5 mV	10 mV/0.5 mV
2 mV <sup>4</sup>	±2 mV	-1 mV to 1 mV	4 mV/0.2 mV
1 mV <sup>4</sup>	±1 mV	-0.5 mV to 0.5 mV	2 mV/0.1 mV

<sup>1</sup> for voltage input unit <sup>2</sup> for universal input unit

<sup>3</sup> Maximum input voltage is 350VDC + ACpeak

<sup>4</sup> for strain input unit

## 3.3.2 How to Set the Measurement Range and Full Scale Values

### What You Should Know

#### Measurement Range

The measurement range is the maximum range through which measurement is possible. The measurement range setting also determines the recording range and the measuring resolution. Refer to table 3.1.

#### Full-Scale Values

Full scale values are the maximum and minimum measurement values that can be recorded within the recording zone which has been designated for analog recording. Immediately following the measurement range setting, the full scale values are designated as 1/2 of the actual measurement range.

The relationship between the measurement range and the full-scale values are shown in the figure below.

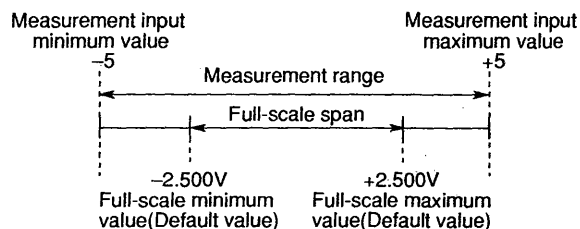

#### Thermocouple inputs: (Universal input unit only)

Measurement Range	Actual Measurement Range	Initial Full-Scale Values	Maximum / Minimum Full-Scale Spans
K	-200.0 to 1300.0°C	-200.0 to 1300.0°C	1500.0°C/100.0°C
J	-200.0 to 1100.0°C	-200.0 to 1100.0°C	1300.0°C/75.0°C
E	-200.0 to 800.0°C	-200.0 to 800.0°C	1000.0°C/60.0°C
T	-200.0 to 400.0°C	-200.0 to 400.0°C	600.0°C/30.0°C
L	-200.0 to 900.0°C	-200.0 to 900.0°C	1100.0°C/75.0°C
U	-200.0 to 400.0°C	-200.0 to 400.0°C	600.0°C/30.0°C
R	0.0 to 1700.0°C	0.0 to 1700.0°C	1700.0°C/125.0°C
S	0.0 to 1700.0°C	0.0 to 1700.0°C	1700.0°C/125.0°C
B	0.0 to 1800.0°C	0.0 to 1800.0°C	1800.0°C/125.0°C
N	0.0 to 1300.0°C	0.0 to 1300.0°C	1300.0°C/100.0°C
W	0.0 to 2300.0°C	0.0 to 2300.0°C	2300.0°C/175.0°C

RMS inputs (for RMS converter units only):

Measurement Range	Actual Measurement Range	Initial Full-Scale Values	Maximum/Minimum Full-Scale Spans
500 V	0 to 350 Vrms	0 V to 500 V	500 V/50 V
200 V	0 to 200 Vrms	0 V to 200 V	200 V/20 V
100 V	0 to 100 Vrms	0 V to 100 V	100 V/10 V
50 V	0 to 50 Vrms	0 V to 50 V	50 V/5 V
20 V	0 to 20 Vrms	0 V to 20 V	20 V/2 V
10 V	0 to 10 Vrms	0 V to 10 V	10 V/1 V
5 V	0 to 5 Vrms	0 V to 5 V	5 V/0.5 V
2 V	0 to 2 Vrms	0 V to 2 V	2 V/0.2 V
1 V	0 to 1 Vrms	0 V to 1 V	1 V/0.1 V
500 mV	0 to 500 mVrms	0 mV to 500 mV	500 mV/50 mV
200 mV	0 to 200 mVrms	0 mV to 200 mV	200 mV/20 mV
100 mV	0 to 100 mVrms	0 mV to 100 mV	100 mV/10 mV

Frequency inputs (for frequency input units and power line freq. input unit only):

Measurement Range	Actual Measurement Range	Initial Full-Scale Values	Maximum/Minimum Full-Scale Spans
100 Hz	0 to 100 Hz	0 to 100 Hz	100 Hz/10 Hz
200 Hz	0 to 200 Hz	0 to 200 Hz	200 Hz/20 Hz
500 Hz	0 to 500 Hz	0 to 500 Hz	500 Hz/50 Hz
1000 Hz	0 to 1000 Hz	0 to 1000 Hz	1000 Hz/100 Hz
2000 Hz	0 to 2000 Hz	0 to 2000 Hz	2000 Hz/200 Hz
5000 Hz	0 to 5000 Hz	0 to 5000 Hz	5000 Hz/500 Hz
10000 Hz	0 to 10000 Hz	0 to 10000 Hz	10000 Hz/1000 Hz
50 Hz	40 to 60 Hz	45 to 55 Hz	20 Hz/2 Hz
60 Hz	50 to 70 Hz	55 to 65 Hz	20 Hz/2 Hz

Strain inputs (for strain input units only):

Measurement Range	Actual Measurement Range	Initial Full-Scale Values	Maximum/Minimum Full-Scale Spans
20000 µε	±20000 µε	-10000 µε to 10000 µε	40000 µε / 2000 µε
10000 µε	±10000 µε	-5000 µε to 5000 µε	20000 µε / 1000 µε
5000 µε	±5000 µε	-2500 µε to 2500 µε	10000 µε / 500 µε
2000 µε	±2000 µε	-1000 µε to 1000 µε	4000 µε / 200 µε
1000 µε	±1000 µε	-500 µε to 500 µε	2000 µε / 100 µε

## Operating Procedure

### Measurement Range / Full-Scale Values

- 1 Press the CH-key for which you want to set the measurement range.
  - 2 Press the RANGE part of the POSITION/RANGE-key. The LED will light.
  - 3 Turn the rotary knob to set the measurement range.
  - 4 If required, you can adjust the full-scale values by turning the rotary knob after having pressed the FINE-key.
- In case of frequency units, press the soft key.
- 5 To set the measurement range for an other channel, press the CH-key of that channel and repeat step 1 to 4. To copy the settings to other channels, refer to page 3-8.

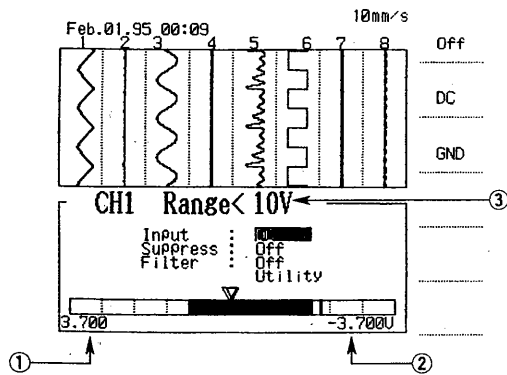

- ① Maximum full-scale value
- ② Minimum full-scale value
- ③ Measurement range setting

If you select a recording zone smaller than the measurement range, the symbol "<" appears.

### NOTES

- The rotary knob can be used to set the measurement range by first pressing the RANGE part of the POSITION/RANGE-key. Turning the knob clockwise results in decreasing the setting value (and therefore increasing the waveform size).

- You can easily reset the full-scale value to the default setting value. To do so, move the cursor onto the "Utility" setting and select "Reset" using the soft keys.
- If the measurement setting is changed while a voltage is being input (input type setting is DC or GND), the full-scale span will be changed to its initial setting value following the measurement range setting change. However, the zero-position will not be changed.
- The full-scale values will not be changed even if the input type setting is switched between DC and GND.
- The measurement range and full-scale values may be changed during real-time recording. However, they cannot be changed during data capture operations.
- Existing memory block data will be deleted if a data capture operation is started following certain "input type" or "measurement range" setting changes. The new data will then be captured to memory block number 1. The input type changes are
  - from DC, GND to TEMP or OFF
  - from TEMP to DC, GND or OFF
- When designating the linear scaling setting, the full-scale values are displayed as linear scaling values. For details regarding linear scaling settings, refer to 9.1.

## Operating Procedure

### Recording Position

- 1 When you are continuing with the previous settings, skip this step. Otherwise, press the CH-key to display the "Input Setting" screen.
- 2 Press the POSITION part of the POSITION/RANGE-key. The LED will light.
- 3 Turn the rotary knob to set the recording position. The triangle corresponds with the zero level.
- 4 If required, you can set the recording position more accurately by turning the rotary knob after having pressed the FINE-key.
- 5 To set the recording position for an other channel, press the CH-key of that channel and repeat step 1 to 4. To copy the settings to other channels, refer to page 3-8.



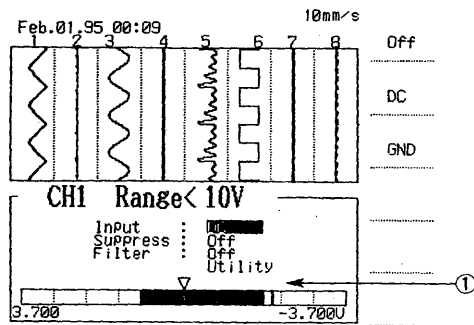

① Zero position mark

#### NOTES

- The rotary knob can be used to set the recording position of the waveform by first pressing the POSITION part of the POSITION/RANGE-key. Turning the knob clockwise results in moving the recording position to the right (by actually moving the scale).
- You can easily reset the full-scale value to the default setting value. To do so, move the cursor onto the "Utility" setting and select "Scale Reset" using the soft keys.

#### Automatic Full-Scale Setting (Auto Scale)

This function automatically designates the minimum and maximum full scale settings according to the measurement inputs. When the "Auto scale" soft key (located within the "Utility" menu) is pressed, the maximum and minimum values for a measurement input of approximately five seconds are detected. These detected values are then designated as the maximum and minimum full scale values. You can reset the full scale values by pressing the "Scale Reset" soft key.

However, when using the auto scale function, be aware of the following:

If the detected minimum and maximum values exceed the measurement range, they will be revised to the minimum and maximum full-scale values. The data lying outside this range will not be measured. In such a case, adjust the measurement range.

If the difference between the detected minimum and maximum values is less than the default minimum full scale span, the detected minimum value will become the minimum full scale span. The maximum full scale value will be decided according to the minimum full scale span.

### 3.3.3 How to Set a Suppression Voltage

This section describes the way to set the suppression voltage to add or subtract a certain offset value.

#### What You Should Know

##### Setting Range of the Suppression Voltage

In case the measurement range is 100mV to 5V:

-10.00 to 10.00V

In case the measurement range is 10V to 500V:

-500 to 500V.

#### Permissible Measurement Ranges when Using Suppression Voltage

Range	Suppression Voltage Setting Range	Input Voltage Range
100mV 200mV 500mV 1V 2V 5V	-10.00 to 10.00V	$\pm 10V^{*1}$
10V 20V 50V 100V 200V 500V	-500 to 500V	$\pm 350V$

#### Displaying the Suppression Voltage

The suppression voltages will appear in the scale display and printout, digital display and printout, communication output and when highlighted by the cursor.

#### NOTES

- The suppression voltages will be ignored in case of performing arithmetic or statistical computations.
- When you use linear scaling, the suppressed voltage values will not be printed or displayed.

#### Operating Procedure

The initial value is "OFF".

- 1 Press the CH-key of the channel you want to set.
- 2 Move the cursor to the "Suppress" setting.
- 3 Press the "ON" soft key.
- 4 Set the voltage value using the rotary knob.

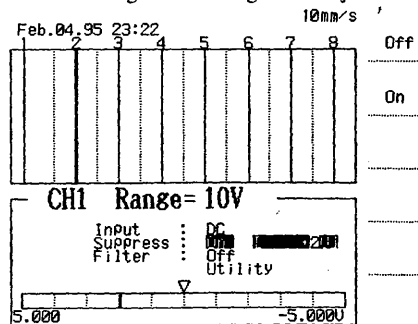

### 3.3.4 Calibration for RMS Measurement (only when RMS converter unit is applied)

This section describes how to perform calibration for RMS measurement in case you need even more accurate measurements.

- **Points to note when performing this calibration**

These calibrated data will only be kept until the power is turned OFF. In case you want to keep these data after power OFF, make sure to turn backing-up data ON (refer to 9.3 Changing System Settings).

#### Operating Procedure

1. Press the CH-key for which you want to perform calibration.
2. Verify that the input mode is set to 'RMS'.
3. Press the CAL soft key. The message 'RMS calibration' appears in the upper left screen, and calibration is finished when the message disappears.

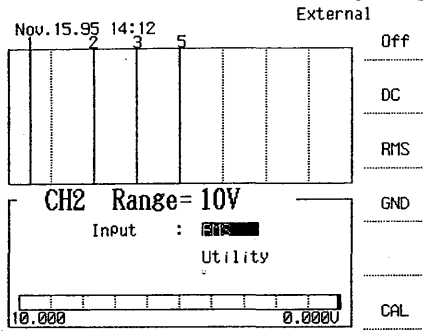

### 3.3.5 Setting the Bridge Excitation Voltage (only for strain input unit)

When you are using the strain input unit, it is necessary to set this excited voltage.

#### CAUTION

Make sure to disconnect the strain gage, strain gage converter etc. from the strain input unit before changing the value of the excited voltage. The strain gage, strain gage converter etc. might be damaged when setting a wrong excited voltage.

#### Bridge excitation voltage selections

Select the appropriate excited voltage from the table below. However, since the excited voltages depend on the adjustive gage resistances, select accordingly.

Excited Voltage	Gage Resistance
2 V	120 $\Omega$ to 1 k $\Omega$
3 V	
5 V	350 $\Omega$ to 1 k $\Omega$
10 V	

#### Operating Procedure

The initial value is 2V.

1. Press the CH-key which you want to set.
2. Move the cursor to the 'BV' setting.
3. Select the appropriate excited voltage.

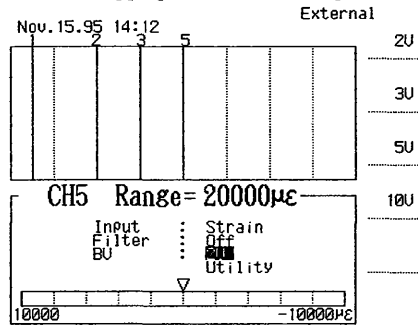

### 3.3.6 Adjusting the Strain Balance (only for strain input unit)

This section describes the way to eliminate the unbalanced part of the bridge resistance of the strain gage, strain gage converter etc.

The following two methods exist.

- **All adjust**  
All the channels for which the input mode is set to 'Strain' will be balanced.
- **Adjust**  
Only the channel which is currently being displayed will be balanced.

### Operating Procedure

1. Press the CH-key for which you want to carry out strain balancing.
2. Verify that its input mode is set to 'Strain'.
3. Select 'All adjust' or 'adjust' using the soft keys.

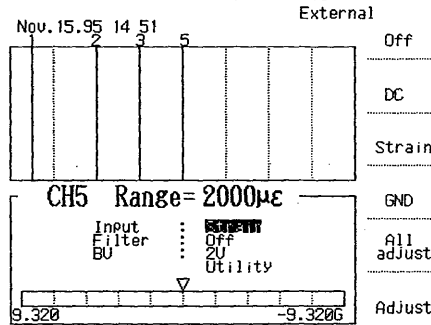

#### NOTE

Strain balance need not be executed but after the following situations.

- When changing the input mode to others than 'Strain'.

However, balanced will be kept even after the power is turned OFF.

### 3.3.7 How to Copy Settings to Another Channel

You can conveniently copy settings to other channels. Proceed as follows:

- 1 Press the CH-key of the channel whose values you want to copy to other channels. The "Input Setting" screen will appear.
- 2 Move the cursor onto the "Utility" command.
- 3 Press the "Copy to" soft key.
- 4 Move the cursor onto the channel of destination.
- 5 Press the "yes" soft key.
- 6 Repeat the last two steps for other destination channels.
- 7 Press the "Copy execute" soft key. The display will return to the "Input Setting" screen once the soft key has been pressed. The "Copy completed" message appears on the screen when copying has been finished.

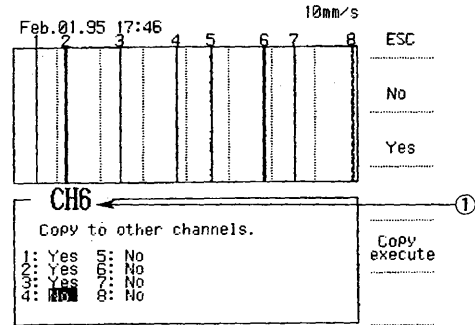

① Source channel

#### NOTE

It is not possible to copy the setting contents from channels of one input unit to channels of a different kind of input unit.

## 3.4 Using the Monitor Screen

### 3.4.1 Switching Between Monitor Screens

#### What You Should Know

##### Screen Sequence

The sequence of the screens which appear by pressing the MONITOR-key starts with the Analog Waveform screen, followed by the Logic Waveform screen if this option is installed, followed by the Numeric Value screen and by the Full-Scale Value screen.

##### Analog Waveform Screen

This screen is used to monitor the recording of analog and logic waveforms. Waveforms will be displayed according to the settings you set in the Recording Setting screen (see chapter 4). The waveforms scroll from the top of the screen down. Note that X-Y waveforms will not be displayed, but T-Y is displayed. Note that when your recorder is equipped with the optional logic input channels, these will be displayed after pressing the MONITOR-key after the Analog Waveform screen again.

The rate at which Analog Waveform screens scroll down depends on the chart speed. See also 12.5. This display looks as follows:

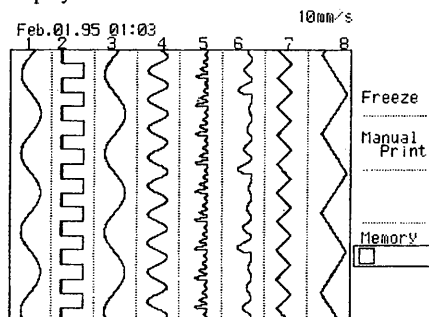

##### Numeric Values Screen

This screen is used to monitor the recording of digital logging. Data of all channels, provided they are not set to OFF, will be displayed as numeric values. The values are updated every 0.5 seconds. When the measured value lies outside the measurement range, +\*\*\*\*\*V will be displayed to indicate an overrange condition. This display looks as follows:

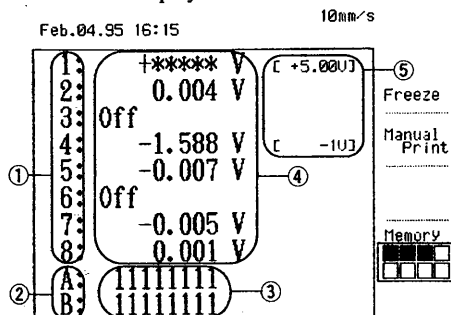

- ① Channel number
- ② Logic channels
- ③ Logic data
- ④ Analog data
- ⑤ Suppression voltage value

##### Full-Scale Values Screen

This screen displays the previously set maximum and minimum values for all channels. This display looks as follows:

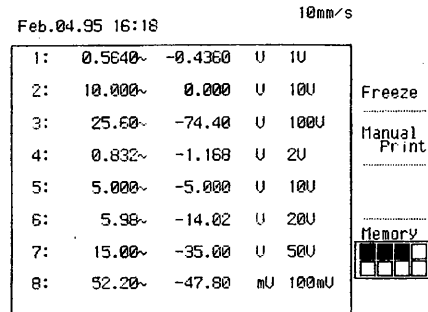

#### Operating Procedure

##### Selecting the Monitor screen

- 1 Press the MONITOR-key once.
- 2 Continuing to press the MONITOR-key results in displaying the Numeric Values screen, the Logic Waveform and the Full Scale Values screen respectively.

##### Switching the Monitor screen at the Input Setting screen

The Input Setting screen (which appears by pressing any CH-key) also displays the Monitor screen at the upper half of the screen. It is possible to switch this Monitor screen while you are active in the Input Setting screen. Proceed as follows:

- 1 Move the cursor onto the "Utility" command.
- 2 Press the "Monitor" soft key until you reach the screen you want. You can enter settings as before in the lower half of the screen.

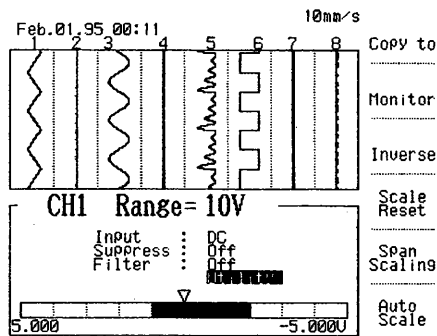

#### NOTE

You cannot switch between Monitor screens during recording. When you start recording, the currently selected screen remains active.

### 3.4.2 Freezing the Monitor Screen

This section describes the way to "freeze" the monitor screen which is useful for viewing specific data.

#### Operating Procedure

- 1 Press the Monitor-key several times until the required monitor screen comes up.
- 2 Press the Freeze soft-key. The display will "freeze" the data on the screen.  
However, data sampling continues.
- 3 To release the "freeze-status", press the MONITOR-key.

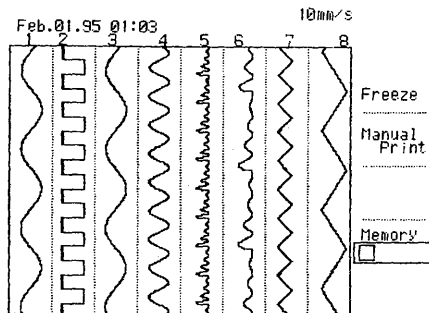

#### NOTE

When capturing data or playing back captured data, this "freeze"-function cannot be used.

### 3.4.3 Getting a Manual Printout

#### What You Should Know

Manual printouts consist of the latest measurement data, printed digitally.

A manual printout can be obtained in several ways.

- by pressing the "manual print"-soft key at the monitor display.
- by pressing the "manual print"-soft key during real-time recording (chart speed should be 10mm/s or less, and "data manual" should be set at the annotation setting).
- by external input signal (refer to 9.6)
- by communication interface.

The result of the first operation looks as follows.

23:26:42 1= 1.982V 2= -0.992V 3= 0.005V

#### Operating Procedure

- 1 Press the MONITOR-key several times until the required monitor-screen comes up.
- 2 Press the "manual print" soft key. One line of measurement data will be printed.

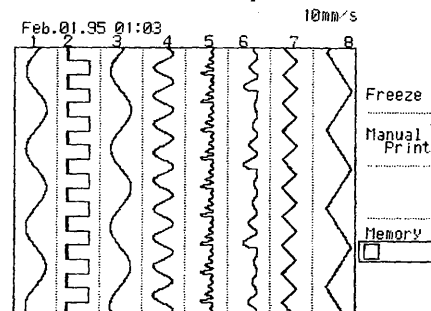

### 3.5 Date and Time Settings

This section describes how to set the date and time which will be used to be printed or displayed.

#### What You Should Know

##### Setting the Date

You don't have to enter the slashes.

e.g. 94/12/31 (year/month/day)

Leap years are automatically provided.

##### Setting the Time

You don't have to enter the colons.

e.g. 14:05:00 (hour:minute:second)

#### Operating Procedure

- 1 Press the MENU-key.
- 2 Press the NEXT soft key and select "#9 System".
- 3 Select "#1 System" using the soft keys.
- 4 Move the cursor onto the date setting.
- 5 Select the required number by turning the rotary knob.
- 6 Use the cursor keys to move to the next number (within the date setting) which you want to adjust.
- 7 Once you set the required date, press the "Setting" soft key. The cursor will move to the time setting.
- 8 Select the required number by turning the rotary knob.
- 9 Use the cursor keys to move to the next number (within the time setting) which you want to adjust. You can select the next number now. Once you set the new time, press the "Setting" soft key.

System	
Date	: 95/02/01
Time	: 17:51:55
Back ground	: White
Display language	: English

Setting									
1	2	3	4	5	6	7	8	9	ESC

#### NOTES

- If you press the "ESC" soft key before you press the "Setting" soft key, the old setting will be kept.
- This setting screen will show the time when the screen was opened and does not change on the screen. However, the internal clock keeps working as usual.
- The new time starts as soon as you press the "Setting" soft key.

### 3.6 Changing the Language of the Display

This section describes how you can change the language used on the display.

#### What You Should Know

The display can appear in the following languages.

- English
- German
- French
- Japanese

#### Operating Procedure

The initial setting is English.

- 1 Press the MENU-key.
- 2 Press the NEXT soft key and select "#9 System".
- 3 Move the cursor onto the "Display language" setting.
- 4 Select the required language using the soft keys.

System		English
Date	: 95/02/01	.....
Time	: 04:16:20	.....
Back ground	: White	.....
Display language	: English	77
		.....
		Français
		.....
		Deutsch
		.....
		.....
		.....

# Real-Time Recording

This chapter describes the initial recording settings, how to start/stop real-time recording, and how to adjust the recording format. When triggering is required, refer to chapter 6.

## 4.1 Initial Recording Settings

The initial settings for real-time recording are as follows (printed in bold script):

Print Format screen (Press the MENU-key and select #2)

Parameter	Description	Values
Mode	Selects analog waveforms or digital logging recording	<b>Analog</b> , Digital
Format	Selects the number of zones for T-Y recording, or selects X-Y recording	1 Zone 200mm, 1 Zone 160mm 2 Zone, 4 Zone, <b>8 Zone</b> , X-Y
Grid Intensity	Selects the intensity of the grid in printouts	Normal, <b>dark</b>
Grid Type	Selects a type of grid	Off, <b>10mm fine</b> , 10mm simple, 10div fine, 10div simple
Scale Print	Selects whether to print the scale	Off, <b>On</b>
Annotation	Selects whether to print an annotation	<b>Off</b> , On, CH.Info., Data Distance, Data Manual
Channel Print	Selects whether to print the channel number and at which interval	Off, 200, <b>400</b> , 1000, 2000
Header Print	Selects whether to print date, time, chart speed and comments	Off, <b>Time</b> , Comments, Time + Comments
Flexible Zone	Selects zone recording ON/OFF and whether to print outside its boundaries	<b>Off</b> , Boundary, w/o Boundary
Shot Recording	Selects shot recording and its length	<b>Off</b> , 0.2, 0.5, 1, 2 m
Tick/Event	Selects whether to print time tick or event and the interval of the time tick	Off, Event, 0.01, 0.1, <b>1</b> , 10, 60 s
Assign X-Axis	Assigns the horizontal axis	<b>Off</b> , CH1, CH2, ..., CH8
Assign Y-Axis	Assigns the vertical axis	<b>Off</b> , CH1, CH2, ..., CH8
Time Interval	Selects the interval for digital logging	<b>1</b> , 2, 5, 10, 20, 30, 60 s, 1, 2, 5, 10, 20, 30, 60 min
Direction	Selects the direction of the printout	<b>Normal</b> , 180° rotation

Trace Setting screen (Press the MENU-key and select #1).

Parameter	Description	Values
Trace	Selects whether to print a waveform and its intensity	Off, <b>Dark</b> , Light

Flexible Zone Adjust screen (Press the MENU-key, select #5 and then 1 "Zone"):

Parameter	Description	Values
Upper	Sets the upper value of the zone	1 to 100
Lower	Sets the lower value of the zone	0 to 99

Event Message Set screen (Press the MENU-key, select #9 and then 2 "Event message"):

Parameter	Description	Values
Event message	Selects event message mode	<b>Off</b> , Time, Message, Time + Message

The following table shows which settings are selectable for three types of recording.

The real-time recording of logic channels will be done together with the analog T-Y waveforms. Therefore, for settings concerning logic recording, refer to that column. However, the settings with an asterisk apply to analog T-Y waveforms only.

Setting	Analog T-Y Waveform	Analog X-Y waveform	Numeric Values Recording	Reference Page
Mode	Analog	Analog	Digital	4-5
Format	except X-Y	X-Y	x	4-5
Grid Intensity	o	o	x	4-5
Grid Type	o	o	x	4-5
Scale Print* (On/Off)	o	o	x	4-8
Annotation Print*	o	o	x	4-6
Channel Print*	o	o	x	4-7
Header Print	o	o	x	4-8
Flexible Zone	o	x	x	4-5
Shot Recording	o	x	x	4-12
Tick/Event	o	x	x	4-13
Assign X-axis	x	o	x	4-10
Assign Y-axis	x	o	x	4-10
Time Interval	x	x	o	4-11
Direction	x	x	o	4-12

Setting	Analog T-Y Waveform	Analog X-Y waveform	Numeric Values Recording	Reference Page
Chart speed	o	x	x	4-3
Trace	o	x	x	4-9

o: setting is possible  
x: setting is not possible  
\*: not for logic waveforms



## 4.2 Starting / Stopping Real-Time Recording

This section describes how to start and stop real-time recording.

### What You Should Know

You can interrupt the current recording process using the RECORD START/STOP-key under the following conditions:

- During a single shot recording
- When performing data capture during real-time recording. You can only interrupt the current process during the real-time recording.

### Operating Procedure

#### T-Y Recording

You can start T-Y recording after you selected all the necessary settings by simply pressing the RECORD START/STOP-key. Pressing the same key again results in stopping the recording.

#### X-Y Recording

In case of X-Y recording, pressing the RECORD START/STOP-key results in the creation of image data of X-Y. Pressing the same key again results in starting the recording. After the recording has been completed, recording will stop.

Note that the screen will show the T-Y display.

#### NOTES

- Real-time recording cannot be started under the following conditions:
  - During data capture
  - When displaying captured data
  - When printing captured data
  - When accessing a Floppy disk
  - When printing out a setup list
  - When printing out a hardcopy.
- When you selected the repeat or single trigger mode and you press the RECORD START/STOP-key, real-time recording will not start as long as the trigger conditions are not satisfied. Refer to chapter 6.
- When recording starts, the screen turns to the "Monitor" screen. The "Monitor" screen can be changed by pressing the MONITOR-key.
- Note that waveforms will not be recorded for channels whose trace intensity was set to "Off." See 4.10.

## 4.3 Chart Speed Setting

This section describes the way to change the chart speed using the front panel keys.

### What You Should Know

The chart speed can be set to any of the following speeds:

mm/s : 1, 2, 5, 10, 25, 50, 100, 200, 250  
mm/min : 1, 2, 5, 10, 25, 50, 100, 200, 250  
mm/h : 10, 25, 50, 100, 200, 250

The intervals between the grids on the time axis differ depending on whether the chart speed is set at 250 mm/s or any other speed.

The rule applies to all types of grids (see Section 4.5).

With the chart speed set at a speed other than 250 mm/s

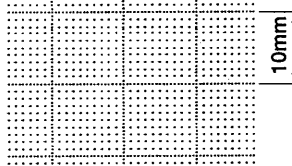

With the chart speed set at 250 mm/s

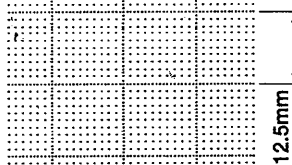

Two additional chart speeds are available which you can set yourself; they are  $V_1$  and  $V_2$  and can be set to 1 to 200 mm/s, 1 to 200 mm/min, 10 to 200 mm/h. These chart speeds can be triggered (See 6.3).

#### NOTE

The chart speed cannot be changed while data capturing is in progress, while loading or saving, while printing out a setup list or while printing out/ displaying captured data is in progress.

## Operating Procedure

### Setting the Chart Speed

- 1 Press the CHART SPEED-key.
- 2 Use the cursor keys or rotary knob to move the cursor onto the desired chart speed. The chart speed will change accordingly.
- 3 Select the unit using the soft keys. The chart speed will change accordingly.

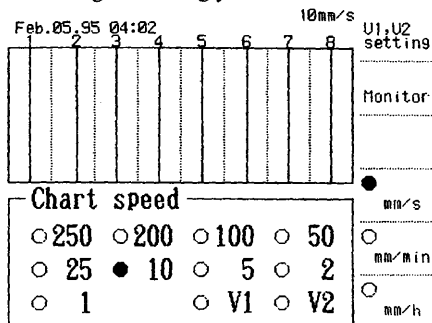

### NOTES

- It is also possible to have the chart speed changed after triggering occurs. See 6.3.
- When using the recorder for a long time at low speeds, dust might gather at the printer head, which results in no printout. In such a case, perform "Cleaning the Printer Head", as described in 11.4.

### Setting the Additional Chart Speed V<sub>1</sub>, V<sub>2</sub>

- 1 Press the CHART SPEED-key.
- 2 Select "V<sub>1</sub>, V<sub>2</sub> Setting" using the soft keys.
- 4 Turn the rotary knob until the required value is shown.
- 5 Select the appropriate unit.
- 6 Press the ESC-key to return to the previous screen.
- 7 Select V<sub>1</sub> or V<sub>2</sub> using the rotary knob.

## 4.4 Fixed and Flexible Zone Recording

This section describes how to record T-Y analog waveforms in different zones. This has the advantage that waveforms can be recorded without overlap. The recorder has pre-set fixed zones, but you can set the width of the zones yourself too (flexible zone recording).

### What You Should Know

#### Types of Fixed Zones

Zone Setting	Recording Width	On Each Zone
1 zone 200 mm	200 mm	All waveforms* <sup>1</sup>
1 zone 160 mm	160 mm	All waveforms* <sup>2</sup>
2 zones	80 mm	1-4ch input: max. 2 waveforms 5-8ch input: max. 4 waveforms
4 zones	40 mm	1-4ch input: max. 1 waveform 5-8ch input: max. 2 waveforms
8 zones	20 mm	1-8ch input: max. 1 waveform

\*<sup>1</sup> messages, annotations, logic waveforms (option) will overlap with the analog waveforms

\*<sup>2</sup> messages, annotations, logic waveforms (option) will not overlap with the analog waveforms

#### Flexible Zones

Flexible zones can only be set in case 1 Zone 200 mm or 1 Zone 160 mm has been set at the Format setting. The zones are decided by setting the upper and lower limit values in terms of percentage. The maximum value is 100%.

The lower limit can be set from 0 to 99% of the recording span, the upper limit from 1 to 100%, selectable for each channel.

The lower limit can not be bigger than the upper limit. The minimum width of a zone is 1%, the maximum width is 100%.

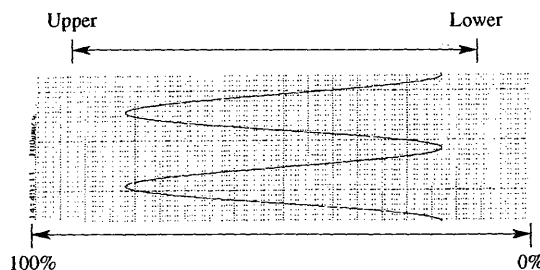

#### Logic Signals and Zones

The logic signals CH-A and CH-B will be recorded in zones too. Refer to 4.17 for more details.

### Assigning Channels to Zones

In case of using fixed zones, the channels are assigned to the zones as shown in the following table. The table shows the situation for the 8-channel model.

8Zone	4Zone	2Zone	1Zone
CH1	CH1, 2	CH1~4 (CH1, 2)	CH1~8 (CH1~4)
CH2			
CH3	CH3, 4	CH5~8 (CH3, 4)	
CH4			
CH5	CH5, 6	CH5~8 (CH3, 4)	
CH6			
CH7	CH7, 8		
CH8			

(in case the 4-ch input unit is connected)

### Recording outside Zones

You can select how you want to record data which fall outside the set zone. You can still have them recorded, or not, by setting whether data should be recorded beyond the zone's boundaries.

### Recording outside the Zones

In case you are using flexible zones and select the setting "w/o Boundary", the measurement data will appear outside the boundaries also.

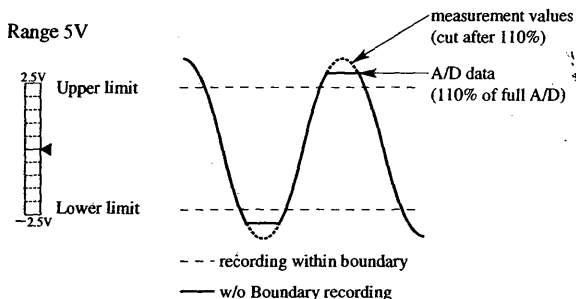

Make sure that "1 zone 200mm" or "1 Zone 160 mm" at the "Format" setting of the "#2 Print format" screen (see operating procedure for fixed zones) is selected.

- 1 Press the MENU-key.
- 2 Press the NEXT soft key and select "#6 Flexible zone adjust".
- 3 Move the cursor to the 'Upper' setting of the channel for which you want to adjust the zone.
- 4 Set the upper value using the rotary knob.
- 5 Move the cursor to the 'Lower' setting.
- 6 Set the lower value using the rotary knob.
- 7 Repeat step 3 to 6 for all the channels you want to adjust.

Flexible zone adjustment		
CH	Upper	Lower
1	500	0%
2	1000	40%
3	500	60%
4	1000	80%
5	500	50%
6	1000	80%
7	1000	80%
8	1000	80%

### Recording outside Zones

"OFF" is the initial value.

- 1 Press the MENU-key.
- 2 Select "#2 Print format" using the soft keys.
- 3 Move the cursor to the "Flexible zone" setting.
- 4 Select from one of the following:
  - OFF Zone recording will not be done
  - Boundary Data lying outside the boundaries will not be recorded.
  - w/o Boundary Data lying outside the boundaries will still be recorded.

## Operating Procedure

### Fixed Zones

- 1 Press the MENU-key.
- 2 Select "#2 Print format" using the soft keys.
- 3 Make sure that "Analog" is selected at the Mode setting. Zone recording is meaningless for the digital logging mode.
- 4 Move the cursor to the "Format" setting.
- 5 Select the number of zones using the soft keys.

Print format	1 Zone 200mm
Mode	1 Zone 160mm
Format	2 Zone
Grid intensity	4 Zone
Grid type	8 Zone
Scale print	X - Y
Annotation	
Channel print	
Header print	
Flexible zone	
Shot recording	
Tick / Event	

### Flexible Zones

## 4.5 Selecting the Grid Type and Grid Intensity

This section describes how to select the most appropriate grid to analyze your printouts.

### What You Should Know

#### Grid Types

You can select one of the following four grid types shown below. It is also possible to record waveforms without using a grid (off).

Note that you cannot change the grid type during real-time recording.

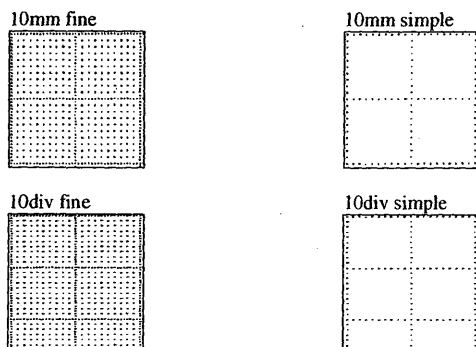

The grid intensity can be selected from normal and dark.

### Operating Procedure

#### Selecting the Grid Intensity

"Normal" is the initial value.

- 1 Press the MENU-key.
- 2 Select "#2 Print format" using the soft keys.
- 3 Move the cursor to the "Grid intensity" selection.
- 4 Select the grid intensity using the soft keys.

Print format		Normal
Mode	: Analog	
Format	: 8 Zone	
Grid intensity		Dark
Grid type	: 10mm fine	
Scale print	: On	
Annotation	: On	
Channel print	: On [400mm]	
Header print	: Time	
Flexible zone	: Off	
Shot recording		
Tick / Event	: 1 [sec]	

#### Selecting the Grid Type

"10mm fine" is the initial value.

- 1 Press the MENU-key.
- 2 Select "#2 Print format" using the soft keys.
- 3 Move the cursor to the "Grid type" selection.
- 4 Select the grid type using the soft keys.

Print format		Off
Mode	: Analog	
Format	: 8 Zone	
Grid intensity		10mm fine
Grid type	: 10mm simple	
Scale print	: On	
Annotation	: Off	
Channel print	: On [400mm]	
Header print	: Time	
Flexible zone	: Off	
Shot recording		
Tick / Event	: 1 [sec]	
		10div fine
		10div simple

## 4.6 Entering and Printing Messages

This section describes the way to enter and print messages. There are two kinds of messages: one is attached to a channel and can be set for each channel separately. This type is called annotation. The other one is a message which can be voluntarily printed and does not correspond to any channel. This type is called event message.

### What You Should Know

#### Entering Annotations

You can set an annotation for each channel, each one up to 60 characters in length. Entering can be done using the rotary knob to select the characters. The soft keys can be used to insert characters (INS), to delete characters (DEL), to move back space (BS) and to get upper-case characters (CAPS). It is also possible to copy annotations to other channels using the soft key.

#### Printing Annotations

Annotations will only be printed with analog recordings. Your annotations will be printed repeatedly at a 200 mm interval. Annotations will be truncated when its length exceeds the recording length. Annotations will be printed in the lower area of the recording zone of each channel. In case of "1 Zone 200mm", the annotations and the corresponding waveforms might overlap.

#### Entering Event Messages

A voluntarily event message can be printed during analog recording. Five event messages can be entered each of up to 16 characters. The contents of the printout can be selected from the time (min:sec) only, or the message only, or both. You cannot copy event messages.

#### Printing Event Messages

Printing an event message can be started by key operations, communication command (see IM781011-11E) or external input (see 9.6). However, in case of external input, you cannot select which event message will be printed; they will be printed alternately. When keys are used to start printing, the message which is pointed out by the cursor will be printed.

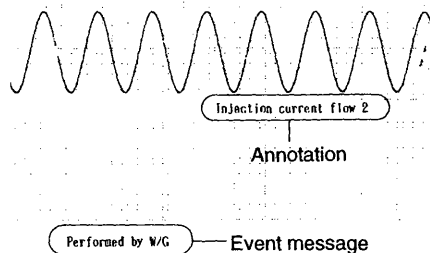

## Operating Procedure

### Entering Annotations

- 1 Press the MENU-key.
- 2 Press the NEXT soft key and select "#8 Comment".
- 3 Move the cursor to the channel for which you want to set an annotation.
- 4 Use the rotary knob to select the character. For more information regarding entering characters, refer to 3.2. Continue until you completed your annotation.

### Copying Annotations

- 5 Move the cursor to the annotation you want to copy.
- 6 Press the "Copy to" soft key.
- 7 Select the number of channel(s) to where you want to copy, by selecting "Yes".
- 8 Press the "Copy execute" soft key.

Header & Annotation [ 23]		Copy to
H: [Real time measuring ]		BS
1: [Remote timing clock ]		DEL
2: [Main transformer Phase 1 ]		INS
3: [Main transformer Phase 2 ]		
4: [Main transformer Phase 3 ]		
5: [Injection current flow ]		
6: [ ]		
7: [ ]		
8: [ ]		

1 " # \$ % & ( ) ( ) ^ _ \   1 2 3	<input type="checkbox"/> CAPS
4 5 6 7 8 9 0 . * ' a b c d e f g h	<input type="checkbox"/> ALP
i j k l m n o p q r s t u v w x y z	<input type="checkbox"/> EU

### Printing Annotations

"On" is the initial value.

- 1 Press the MENU-key.
- 2 Select "#2 Print format" using the soft keys.
- 3 Make sure that "Analog" is selected at the "Mode" setting.
- 4 Move the cursor to the "Annotation" setting.
- 5 Select "On" or "Off" using the soft keys.

Print format		Off
Mode : Analog		On
Format : 8 Zone		CH. info.
Grid intensity : Normal		Data Distance
Grid type : 10mm fine		Data Manual
Scale print : On		
Annotation : On		
Channel print : On [400mm]		
Header print : Time		
Flexible zone : Off		
Shot recording : Off		
Tick / Event : 1 [sec]		

### Printing Channel Information

When you select "Channel Info." at the "Annotation" setting, channel information, such as input mode, range setting, filter, suppression value, and scale value, will be printed instead of annotations.

### Printing Measurement Data

When you select "Data Distance" or "Data Manual", measurement data will be printed digitally instead of annotations.

Selecting Data Distance will result in a digital printout of the measurement data every 40 mm. This is only valid in case the chart speed is less than 10 mm/s and if the chart speed is not controlled by external signal. Selecting Data Manual will result in a digital printout of the measurement data every time you want to. Only valid for chart speeds less than 10 mm/s. For setting by external input or communication, refer to 9.6.

- 1 Press the MENU-key.
- 2 Select "#2 Print format" using the soft keys.
- 3 Make sure that "Analog" is selected at the "Mode" setting.
- 4 Move the cursor to the "Annotation" setting.
- 5 Select "Data Manual" using the soft keys.
- 6 Press the START/STOP-key and verify that recording starts.
- 7 Press the "Manual print"-key at the monitor display and the manual print will appear.

## Operating Procedure

### Entering Event Messages

- 1 Press the MENU-key.
- 2 Press the NEXT soft key and select "#9 System".
- 3 Select "#2 Event message" using the soft keys.
- 4 Move the cursor to the number of the event message which you want to set.
- 5 Use the rotary knob to select the character. For more information regarding entering characters, refer to 3.2. Continue until you completed your event message.
- 6 Move the cursor to the "Print mode" setting.
- 7 Select how you want to have your messages printed using the soft keys. Selectable from time only, message only or time and message, or off.

Event message		Print
# 1 : [Executed by Ber ]		BS
# 2 : [ ]		DEL
# 3 : [ ]		INS
# 4 : [ ]		
# 5 : [ ]		
Print mode : Message		

1 " # \$ % & ( ) ( ) ^ _ \   1 2 3	<input type="checkbox"/> CAPS
4 5 6 7 8 9 0 . * ' a b c d e f g h	<input type="checkbox"/> ALP
i j k l m n o p q r s t u v w x y z	<input type="checkbox"/> EU

### Printing Event Messages

The printing of event messages can be started by the panel keys (explained hereafter), by external input (see 9.6) or by communication. Note that event messages can only be printed during analog recording, and for chart speeds below 100 mm/s.

- 1 Press the MENU-key while recording is in progress.
- 2 Select "#1 Event message" using the soft keys. See figure above.
- 3 Move the cursor to any character within the event message you want to print out.
- 4 Select "Print" using the soft keys to start printing. Note that you can also enter or change event messages on this screen the same way as described above.
- 5 Move the cursor to the "Print mode" and select how you want to have your messages printed. Selectable from time only, message only or time and message, or off.

## 4.7 Printing Channel Numbers

This section describes how to print channel numbers with analog waveforms and how to change the interval of printing channel numbers.

### What You Should Know

#### Location

Channel numbers can be printed beside each waveform. See figure below. However, depending on the waveform, the waveform and channel number might overlap, so the channel number might become hardly visible.

#### Interval

Channel numbers are printed according to a specific interval. The interval is selectable from 200, 400, 1000 or 2000 mm. You cannot change the interval during real-time recording.

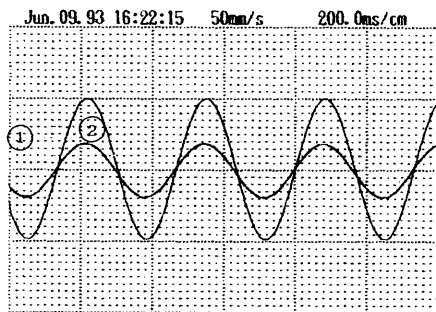

### Operating Procedure

“400” is the initial value.

- 1 Press the MENU-key.
- 2 Select “#2 Print format” using the soft keys.
- 3 Make sure that “Analog” is selected at the “Mode” setting.
- 4 Move the cursor to the “Channel print” setting.
- 5 Select between “Off” or the desired interval using the soft keys.

Print format	Off
Mode : Analog	
Format : 8 Zone	
Grid intensity : Normal	200
Grid type : 10mm fine	
Scale print : On	
Annotation : On	
Channel print : On [400mm]	400
Header print : Time	
Flexible zone : Off	1000
Shot recording : Off	
Tick / Event : 1 [sec]	2000

① Printing interval

#### NOTE

In case of the ‘1 Zone 200 mm’ setting, and the annotation setting is other than Off, the channel No. will not be printed in the designated annotation area (width of 0 to 45 mm).

The channel number will only be printed for chart speeds below 100 mm/s.

## 4.8 Printing the Scale

This section describes how to print the scale together with your analog recordings.

### What You Should Know

#### Contents

The scale printout consists of both full scale values (minimum and maximum), the measurement range, the zero position mark and the zero suppression value (when set).

In case of recording captured data the time axis will be printed.

When the full scale values are changed during real-time recording, the new values will be printed. For an example, refer to page 1-4.

#### Location

Scales can only be printed with analog waveforms.

In case of real-time recording, the scale is printed immediately after recording stops.

In case of printing captured data as an analog waveform, the scale is printed before recording of the waveforms start. A scale can also be printed for X-Y recording.

#### Linear scaling

You can adjust the scaling factor for physical quantities such as mechanical distortion, vibration, pressure and displacement. See also 9.1.

### Operating Procedure

“On” is the initial value.

- 1 Press the MENU-key.
- 2 Select “#2 Print format” using the soft keys.
- 3 Make sure that “Analog” is selected at the “Mode” setting.
- 4 Move the cursor to the “Scale print” setting.
- 5 Select “On” or “Off” using the soft keys.

Print format	Off
Mode : Analog	
Format : 8 Zone	
Grid intensity : Normal	On
Grid type : 10mm fine	
Scale print : On	
Annotation : On	
Channel print : On [400mm]	
Header print : Time	
Flexible zone : Off	
Shot recording : Off	
Tick / Event : 1 [sec]	

## 4.9 Entering and Printing the Header

This section describes how to get a printout of the date, time, chart speed and any comment together with your recording.

### What You Should Know

The header can consist of any of the following, or a combination: date, time, chart speed, any comment. In case of T-Y recording, the header can be printed with a 200 mm interval. The time corresponds with the vertical grid line located just before the first character of the date.

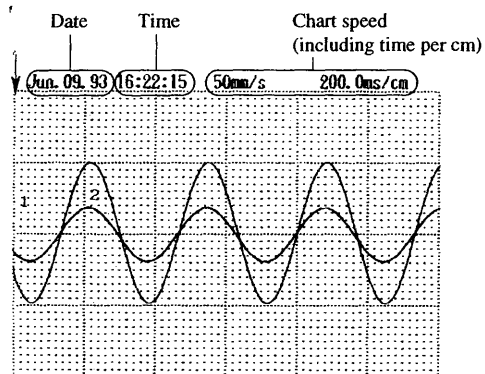

In case of X-Y recording, the time when the recording of image data started and were completed can be printed.

In case of printing captured data, every 40 mm the time scale will be printed.

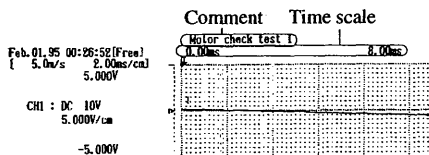
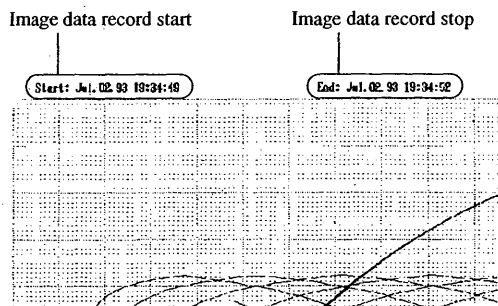

## Operating Procedure

### Entering the Header Comment

The comment of the header can be entered the same way as annotation. Refer to 4.6. The header should be entered at the "H:[ ]" setting.

### Printing the Header

"Time" is the initial value.

- 1 Press the MENU-key.
- 2 Select "#2 Print format" using the soft keys.
- 3 Make sure that "Analog" is selected at the "Mode" setting.
- 4 Move the cursor to the "Header print" setting.
- 5 Select from any of the following:
  - Off header will not be printed
  - Time real-time rec: date, time, chart speed are printed
  - captured data: every 40 mm the time axis will be printed
  - Comment preset comment of up to 60 characters will be printed. In case of data retrieving from a floppy, the file name will be printed.
  - Time + Comment real-time rec: The date, time, chart-speed and comment will be printed.
  - captured data: contents will be divided into two sections, in the upper are the comment will be printed, whereas the lower one will show the time axis every 40 mm.
  - In case of '1 zone 200 mm' setting, the time axis will be printed in the grid.

Event message	Print
# - - - - - [Execute by Bert]	BS
#####	DEL
#####	INS
Print mode : Message	
!"#\$%&'()*~\ :;123	<input type="checkbox"/> CAPS
4567890. * abcdefgh	<input type="checkbox"/> ALP
ijklmnopqrstuvwxyz	<input type="checkbox"/> EU

## 4.10 Selecting Trace Intensity and Turning Channels OFF

This section describes how to select the intensity of the traces.

### What You Should Know

You can choose from two intensities for your waveform: dark and light. You can also choose "off," which results in no recording of the waveform for that channel.

The trace intensity can be changed during real-time recording, but not during data capture.

### Operating Procedure

"Dark" is the initial value.

- 1 Press the MENU-key.
- 2 Select "#1 Trace (T-Y)" using the soft keys.
- 3 Move the cursor to the channel for which you want to adjust the trace setting.
- 4 Select "Off," "Dark" or "Light" using the soft keys.

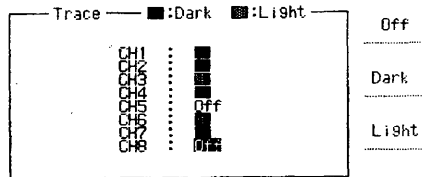

## 4.11 Inverting the Recording

This section describes how to invert the Y-axis in the T-Y recording mode.

### What You Should Know

The Y-axis (vertical axis) can be inverted around the X-axis (horizontal axis).

The full scale values (displayed in the Input Settings screen) will also be inverted accordingly.

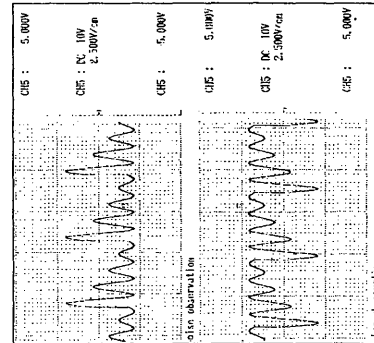

### Operating Procedure

- 1 Press the CH-key of the channel whose recording you want to invert.
- 2 Move the cursor to the "Utility" setting.
- 3 Select "Inverse" using the soft keys. The waveform will be inverted.

You can cancel the inversion by pressing the "Inverse" soft key again.

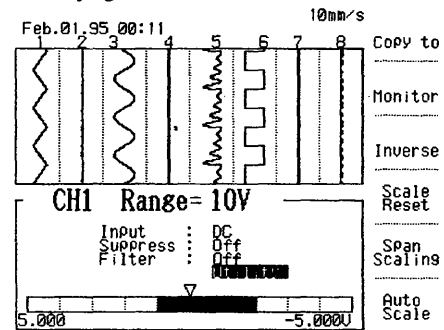



## 4.12 X-Y Recording

This section describes how to get X-Y recordings. X-Y recordings are useful to measure the phase difference between input channels.

### What You Should Know

Up to four graphs can be generated using the input of one channel for the X-axis and using the input of up to four channels for the Y-axis.

### Recording

Pressing the RECORD START/STOP-key once results in creating image data which will be stored into memory. Pressing the same key again results in printing out the stored X-Y image. Refer to the figure below.

### Additional Settings

Within the X-Y recording, you can select the following items:

- Grid type and intensity (see 4.5)
- Scale print ON/OFF (see 4.8)
- Annotations (which will only be printed for the channels corresponding to the X- and Y-axis (see 4.6))
- Channel numbers (which is convenient to see which channel has been assigned to the Y-axis (see 4.7))
- Start/stop time of generating the waveform (see 4.9). The way to select these items is the same as for T-Y recordings. Therefore, refer to the corresponding sections.

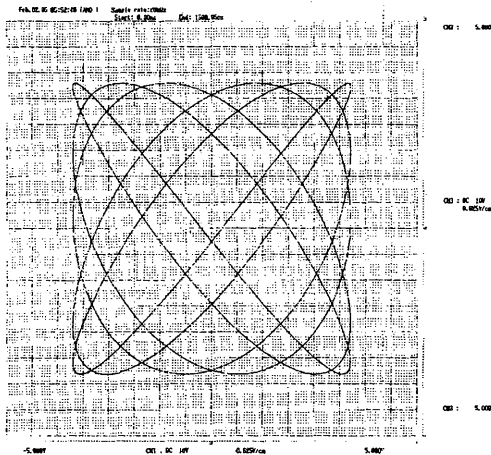

### NOTE

The X-Y recording cannot be monitored on the display screen. The monitor screen will show the data in the T-Y format.

## Operating Procedure

### Assigning Channels to the X- and Y-Axes

The initial value is "CH1" for the X-axis and "CH2" for the Y-axis.

- 1 Press the MENU-key.
- 2 Select "#2 Print format" using the soft keys.
- 3 Make sure that "Analog" is selected at the "Mode" setting.
- 4 Move the cursor to the "Format" setting and select "X-Y" using the soft keys.
- 5 Move the cursor to the "Assign X-Axis" setting and select the channel number which will correspond to the X-axis using the soft keys.
- 6 Move the cursor to the "Assign Y-Axis Graph 1" setting and select, using the soft keys, the channel number which will correspond to the Y-axis of the first graph. You can set up to four graphs here. In case of an input unit of more than four channels, use the "-Next-" soft key to display other channel numbers. Select the Y-axes of other graphs as well, as required.

Print format		1 Zone
Mode	: Analog	200mm
Format	: X-Y	1 Zone
		100mm
Grid intensity	: Dark	2 Zone
Grid type	: 10mm fine	4 Zone
Scale print	: On	8 Zone
Annotation	: Off	X - Y
Channel print	: On	
Header print	: Time	
Assign		
X - Axis	: Off	
Y - Axis Graph 1	: Off	
Graph 2	: Off	
Graph 3	: Off	
Graph 4	: Off	

- 7 Press the RECORD START/STOP-key to start making the image data.
- 8 Press the RECORD START/STOP-key again to start recording.

### NOTE

Depending on the kind of input signal, or when changing the monitor display, etc., the sample rate might change which might affect the recording. Therefore, when a stable recording is necessary, it is recommended to store the data into memory first, and record afterwards.

## 4.13 Digital Logging Recording

This section describes how to record your measurement input as numeric values.

### What You Should Know

The numeric values of your measurement input are printed in the order of the channel number.

You can select one of the following recording intervals:

- 1, 2, 5, 10, 20, 30 or 60 seconds, or
- 2, 5, 10, 20, 30 or 60 minutes.

When the measurement data are outside the measurement range, "+\*\*\*\*\*" will appear. While the measurement range is being changed during numeric recording, "\*\*\*\*\*" will appear.

Within the numeric recording, you can select the following items:

- Printing of channel numbers ON/OFF (see 4.7)
- Printing of date and time (see 4.9).

16:24:56	0.005	21.09	4.95	10.04
16:24:57	0.005	21.09	4.95	10.04
16:24:58	-0.002	21.09	4.95	10.01
16:24:59	0.012	21.09	4.95	10.04
16:25:00	-0.002	21.08	4.95	10.01
16:25:01	-0.002	21.09	4.95	10.01
16:25:02	-0.002	21.08	4.95	10.04

### Operating Procedure

- 1 Press the MENU-key.
- 2 Select "#2 Print format" using the soft keys.
- 3 Move the cursor to the "Mode" setting.
- 4 Select "Digital" using the soft keys.
- 5 Move the cursor to the "Time interval" setting and select it using the soft keys. If the preferred interval is not displayed, press the "-Next-" soft key first.
- 6 Press the RECORD START/STOP-key to start the recording. To stop the recording, press once again.

Print format		Analog
Mode	: Digital	.....
		Digital
Time interval	: 1 [Sec]	.....
Direction	: Normal	.....

## 4.14 Orientation of the Printout

This section describes how to select the most appropriate orientation for your digital printouts.

### What You Should Know

You can select from two types of orientation for your digital printouts:

- Normal,
- 180° rotated.

The difference lies in the presentation of the time axis.

When you look at the printed result in the case of normal, you will find the oldest data on the bottom of the chart and the newest at the top.

When you look at the printed result in the case of 180° rotation, you will find the oldest data on the top of the chart and the newest at the bottom.

#### Normal Printout

16:25:03	-1.001	0.005	0.302	1.217
16:25:05	-1.667	0.005	0.903	0.437
16:25:07	-1.310	0.005	0.004	1.716
16:25:06	0.204	0.005	0.003	2.581
16:25:05	1.953	0.011	0.004	-2.240
16:25:04	1.881	0.005	0.004	0.982
16:25:03	-2.105	0.002	0.004	0.625

#### 180° Printout

16:24:56	0.005	21.09	4.95	10.04
16:24:57	0.005	21.09	4.95	10.04
16:24:58	-0.002	21.09	4.95	10.01
16:24:59	0.012	21.09	4.95	10.04
16:25:00	-0.002	21.08	4.95	10.01
16:25:01	-0.002	21.09	4.95	10.01
16:25:02	-0.002	21.08	4.95	10.04

### Operating Procedure

"Normal" is the initial value.

- 1 Press the MENU-key.
- 2 Select "#2 Print format" using the soft keys.
- 3 Make sure that "Digital" is selected at the "Mode" setting.
- 4 Move the cursor to the "Direction" setting.
- 5 Select "Normal" or "180" using the soft keys.

Print format		Normal
Mode	: Digital	.....
		180
Time interval	: 1 [Sec]	.....
Direction	: Normal	.....

## 4.15 Single-Shot Recording

This section describes how to start a single-shot recording for a preset interval using a one-touch operation.

### What You Should Know

Single-shot recording allows you to record waveforms in real-time on a specified length of chart paper. After the chart travels this specified length, recording will stop.

The length of chart paper used for recording can be selected from the following:  
0.2, 0.5, 1 or 2m.

When the "repeat" trigger mode is selected, single-shot recording will occur at each trigger point (see 6.4.1).

Single-shot recording is only valid during real-time recording of analog waveforms, and is therefore impossible during digital logging or X-Y waveform recording, or during printing of captured data.

### Operating Procedure

"Off" is the initial value.

- 1 Press the MENU-key.
- 2 Select "#2 Print format" using the soft keys.
- 3 Make sure that "Analog" is selected at the "Mode" setting, and that "X-Y" is not selected at the "Format" setting.
- 4 Move the cursor to the "Shot recording" setting.
- 5 Select the required shot length, or "Off" using the soft keys.
- 6 Press the RECORD START/STOP-key to start the recording.

Print format		
Mode	: Analog	Off
Format	: 8 Zone	
Grid intensity : Dark		0.2
Grid type	: 10mm fine	
Scale print	: On	0.5
Annotation	: Off	
Channel print	: On [400mm]	1
Header print	: Time	
Flexible zone	: Off	2
Shot recording : Off		
Tick / Event	: 1 [sec]	

## 4.16 Printing the Time Tick or Event Marker

This section describes how to set and print timing marks to keep track of the time-scale setting. Two kinds are available: time ticks or event markers.

### Time Ticks

Time ticks are printed at the top of the printout and look as follows. Setting can be selected for OFF (no printing) and each 0.01, 0.1, 1, 10 or 60 seconds.

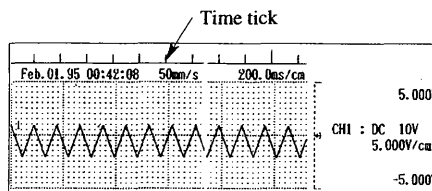

### Event Marker

Event marker can be recorded using external input control. Input a TTL-level signal.

For more details regarding external input controls, refer to 9.8.

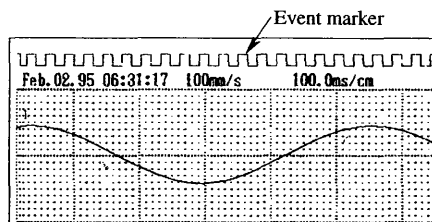

### Operating Procedure

"1 sec" is the initial value.

- 1 Press the MENU-key.
- 2 Select "#2 Print format" using the soft keys.
- 3 Make sure that "Analog" is selected at the "Mode" setting, and that "X-Y" is not selected at the "Format" setting.
- 4 Move the cursor to the "Tick/Event" setting.
- 5 Select the required time tick interval, or, in case event markers are required, "Event".

Print format		
Mode	: Analog	Off
Format	: 8 Zone	
Grid intensity : Dark		Event
Grid type	: 10mm fine	
Scale print	: On	0.01
Annotation	: Off	
Channel print	: On [400mm]	0.1
Header print	: Time	
Flexible zone	: Off	1
Shot recording : Off		
Tick / Event	: 1 [sec]	

-Next-

## 4.17 Logic Recording

This section describes the operation for real-time recording of the optional logic input channels.

### What You Should Know

The logic input option allows you to record up to two channels; CH-A and CH-B. Up to eight signals can be input to each channel.

#### Label

You can attach a label to each channel of up to five characters.

#### Location

The recording of logic waveforms will take place together with the real-time recording of analog T-Y waveforms. The location where the recording appears can be selected by entering a zone number. The number corresponds to the zones as set for T-Y recording. Then the location will be as follows.

- 1 zone 200mm  
The recording of CH-A and CH-B will always appear on the right side of the chart, regardless of your "Print zone" setting.
- 1 zone 160mm  
The recording of CH-A and CH-B will always appear on the right side of the chart, regardless of your "Print zone" setting. The recordings of the logic channels and analog waveforms will not overlap.
- 2 zones - 4 zones  
Recording will be done in the zone which you selected in the "Print zone" setting. When you select the same zone number for CH-A and CH-B, both will be recorded in that zone.
- 8 zones  
Recording will be done in the zone which you selected in the "Print zone" setting. When you select the same zone number for CH-A and CH-B, only CH-A will be recorded.

### Operating Procedure

- 1 Press the MENU-key.
- 2 Select "#10 Logic" using the soft keys.
- 3 Select the input for CH-A and CH-B, which can be "On" or "Off".
- 4 Move the cursor to the "Print zone" setting.
- 5 Select the print zone for CH-A and CH-B. The number corresponds to the zones as set in the "Format" setting on the "Print format" screen. The zones are numbered from the left side of the chart (= 1) to the right side of the chart (=2, 4, or 8). When "1 zone 200mm or 160mm" is selected, CH-A and CH-B will always be recorded on the right side of the chart. "Off" results in no recording.
- 6 Move the cursor to the "Label" setting.
- 7 Here you can set a label for each logic input channel (eight for each channel). These labels will be printed on the chart. The initial values are "A1" to "A8" and "B1" to "B8".

Input	Logic	CH-A	CH-B	
Print	zone	Off	On	Off
Label	1	1	1	On
	2	2	2	
	3	3	3	
	4	4	4	
	5	5	5	
	6	6	6	
	7	7	7	
	8	8	8	

# Data Capture

This chapter describes how to sample measurement inputs and store sampled data into memory, which is called data capture. When triggering is required, refer to chapter 6.

## 5.1 Initial Settings

The initial settings for data capture are as follows (printed in bold script):

Memory Format screen (Press the MENU-key and select #3)

Parameter	Description	Values
Sample Rate	Selects the rate at which the input signal is sampled and stored into memory	100k <sup>1</sup> , <b>50k</b> , 20k, 10k, 5k, 2k, 1k, 500, 200, 100, 50, 20, 10, 5, 2, 1, 0.5, 0.2, 0.1Hz, Ext.
Memory Length	Selects the memory length per channel	<b>1k</b> , 2k, 4k, 8k, 16k, 32k, 64k, 128k, 256k, 512k, 1M
No. of blocks	Selects the number of memory blocks	<b>1</b> , 2, 4, 8, 16

<sup>1</sup> While real-time recording and data capturing are both in progress, the maximum sample rate is 50kHz. In case this situation occurs while 100kHz has been set for the sample rate, an error will occur.

## 5.2 Setting the Sample Rate

This section describes how to set the sample rate, which is the rate at which you sample and store data into the memory.

### What You Should Know

#### Sample Rate

You can select from the following sample rates.  
1, 2, 5, 10, 20, 50, 100 kHz  
0.1, 0.2, 0.5, 1, 2, 5, 10, 20, 50, 100, 200, 500 Hz

It is also possible to select "Ext" for data capture using an external sampling clock. See 9.9.

#### Sample Rate and Data Capture Duration

The data capture duration is equal to the memory length (see 5.3), or number of possible samples, divided by the sample rate. For example the data capture duration to fill 1kdata of memory at a 5Hz sample rate is '1000/5=200s'. The data capture duration is displayed too. The used abbreviations are as follows: ms:msec, s:sec, m:min, h:hour, d:day.

#### Thermocouple Inputs

The sample rate for thermocouple inputs is set to 135Hz. This sample rate cannot be changed, regardless of the sample rate setting. Even when you set the sample rate to be more than or equal to 200Hz, thermocouple input will be sampled at 135Hz.

### Operating Procedure

- 1 Press the MENU-key.
- 2 Select "#3 Memory format" using the soft keys.
- 3 Select the sample rate using the soft keys. If necessary, press the "-Next-" soft key to display the required sample rate.

Memory format	100kHz
Sample rate	1k
Memory length	( 20.0ms)
No. of blocks	50kHz
Playback conditions	
Auto mode	Off
Calculation	Off
Format	Strip chart
Expansion	100 [Data/cm]
Trigger print	On
Block printout	Current only
Data retrieve	Total
	-Next-

#### NOTE

While real-time recording and data capturing are both in progress, the maximum sample rate is 50kHz. In case this situation occurs while 100kHz has been set for the sample rate, an error will occur.

## 5.3 Setting the Memory Length

This section describes how to set the memory length/channel available for data capture.

### What You Should Know

#### Unit

The memory length is expressed in units of data. One sample fills one data. The following memory lengths are available.

1k, 2k, 4k, 8k, 16k, 32k, 64k, 128k, 256k, 512k, 1M

When you divide the memory into blocks (see 5.4), then the memory length of each block will be decided by this setting.

#### Maximum Memory Length

When you set the memory length, the memory of the channels for which no input unit is connected, can be used also.

When all 8 channels are connected, the maximum memory length is 256k data. When you want to assign a memory length of 512k data or more, the number of usable channels becomes limited and are as shown in the figure below. The figure shows the situation for the 8-channel model.

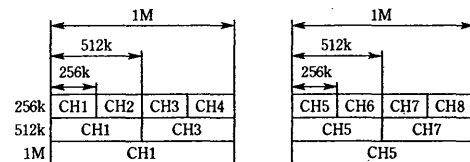

If you select a memory size of 512k, you will be able to use only channel 1, 3 and 5.

If you select a memory size of 1M, you will be able to use only channel 1 and 5.

For logic input channels, the situation is similar as shown below.

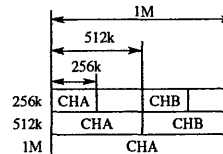

#### Memory Length and Data Capture Duration

The data capture duration is equal to the memory length, or number of possible samples, divided by the sample rate. For example the data capture duration to fill 1kdata of memory at a 5Hz sample rate is '1000/5=200s'. The data capture duration is displayed too. The used abbreviations are as follows: ms:msec, s:sec, m:min, h:hour, d:day.

## Operating Procedure

- 1 Press the MENU-key.
- 2 Select "#3 Memory format" using the soft keys.
- 3 Move the cursor to the "Memory length" setting.
- 4 Select the memory length using the soft keys. If necessary, press the "-Next-" soft key to display the required memory length.

Memory format		1k
Sample rate	: 50kHz	
Memory length	: (20.0ms)	
No. of blocks	: 1	2k
Playback conditions		4k
Auto mode	: Off	
Calculation	: Off	
Format	: Strip chart	8k
Expansion	: 100 [Data/cm] (5.0m/s)	
Trigger Print	: On	16k
Block printout	: Current only	
Data retrieve	: Total	-Next-

## 5.4 Memory Partitioning

This section describes how to divide the memory into blocks. Dividing the memory into blocks makes a more efficient use of the memory possible.

### What You Should Know

#### Number of Blocks

You can divide a channel into 1, 2, 4, 8, or 16 blocks.

#### Number of Blocks and Memory Length

The memory length has consequences for the available number of blocks, as shown below:

Memory Length	Available Number of Blocks				
	1	2	4	8	16
1k	1	2	4	8	16
2k	1	2	4	8	16
4k	1	2	4	8	16
8k	1	2	4	8	16
16k	1	2	4	8	16
32k	1	2	4	8	
64k	1	2	4		
128k	1	2			
256k	1				
512k	1				
1M	1				

In case you are using the mathematical functions, this table doesn't apply. Refer to 7.7.

#### Partitioning Memory and Trigger Modes

You can divide the memory into blocks and trigger data capture as described below (see also chapter 6).

##### Free

Data will be captured without triggering. Data will be stored in the next block each time you press the MEMORY START / STOP-key. When the last block has been used and you press the MEMORY START / STOP-key again, all blocks will be initialized and the data will be stored in block one.

##### Single

After the trigger occurred, only one memory block will be filled. Data capture will stop after this one block is full, regardless whether other triggers occur.

##### Sequence

Every time a trigger occurs, one block will be filled up until all are full. Data capture will stop when all blocks are full, regardless whether other triggers occur.

##### Rotate

Every time a trigger occurs, one block will be filled up until all are full. When all blocks are full and a next trigger occurs, block one will be overwritten. When a next trigger occurs, block two will be overwritten, etc..

## NOTES

- All data will be erased when you start data capturing after you changed the measurement range, memory length, number of blocks, sample rate or input type (except setting changes among DC/GND). In that case, new sampled data will be stored into the memory, starting from the first block.
- If you interrupt data capture by pressing the MEMORY START/STOP-key and then restart data capture, new sampled data will be stored in the next, consecutive block.

## Operating Procedure

- 1 Press the MENU-key.
- 2 Select "#3 Memory format" using the soft keys.
- 3 Move the cursor to the "No. of blocks" setting.
- 4 Select the number of blocks using the soft keys.

Memory format		1
Sample rate	: 50kHz	
Memory length	: 1k	
No. of blocks	: <input type="checkbox"/> ( 20.0ms)	2
Playback conditions		
Auto mode	: Off	4
Calculation	: Off	
Format	: Strip chart	8
Expansion	: 100 [Data/cm] ( 5.0m/s )	
Trigger Print	: On	16
Block Printout	: Current only	
Data retrieve	: Total	

## 5.5 Starting/Stopping Data Capture

This section describes how to start and stop data capture.

### What You Should Know

#### Starting Data Capture

- When the following data is changed before starting data capture, all previous data will be deleted at the time the MEMORY START/STOP-key is pressed;
  - input type (except changes between DC and GND)
  - measurement range
  - sample rate
  - memory length
  - number of memory blocks.

If you do not want to overwrite existing data, you can save your captured data onto a floppy disk before you start data capture.

- When your memory consists of only one block and you start data capture, previous captured data will be deleted.

#### Backup

When you turn the power off after data capture, all captured data will be lost.

When the power is turned off during data capture and turned on again, data capturing will automatically return to previously in progress, provided that the backup setting is set to on. Refer to 9.3. However, data captured before the power was turned off, is lost.

## NOTES

- After you start data capturing using the MEMORY START/STOP-key, all other keys do not operate until data capture stops.
- Immediately after pressing the MEMORY START/STOP-key, there is a period (the TRIGGER READY LED does not light up) during which the trigger conditions, if met, will not start data capture until the data required for trigger detection is captured. Note that this period is longer for lower sample rates.

## Operating Procedure

You can start data capturing by pressing the MEMORY START/STOP-key once. You can stop data capturing by pressing the MEMORY START/STOP-key again.

#### Auto Mode

The Auto mode allows you to combine data capture and printing or saving to the floppy disk automatically. This is useful since captured data would not be kept when a power failure occurs. Therefore, using this function, you can be sure to keep your captured data without any trouble. Refer to 7.3, 7.6.2, 7.7.3 and 8.9.



## NOTES

- Data capture can be started during real-time recording. However, data capture cannot be started when captured data are being printed or while the auto-print function is in progress.
- During data capture, the MEMORY START/STOP display LED is on and "Capturing..." will be displayed. Note that this message will not be displayed during post-triggering is in progress.
- The display screen will change to the Numeric Values screen. During data capture, you cannot change the monitor screen.
- You can interrupt data capture by pressing the MEMORY START/STOP-key again. All data up to the point of interruption will be kept in memory, except in case you interrupted post-trigger data capturing. Then no data will be kept.
- When data capture is completed, the message "Data capture completed" will appear on the screen. However, in case the trigger mode is set to "repeat rotate", this message does not appear.
- If you selected the trigger mode to be either "free" or "single," data capture will stop when the available memory runs out. When the MEMORY START/STOP-key is pressed during data capture, capturing will be interrupted.
- If you selected the trigger mode to be "repeat sequence," data is captured repeatedly until all blocks are full or until you interrupt data capturing by pressing the MEMORY START/STOP-key.
- If you selected the trigger mode to be "repeat rotate," data is captured repeatedly until you interrupt data capturing by pressing the MEMORY START/STOP-key.
- If you interrupt data capturing by pressing the MEMORY START/STOP-key and then start data capture again, the new sampled data will be stored in the next memory block, provided that memory is partitioned. However, when you interrupt the data capture in the last block and then start again, and you are not using the rotate mode, all data will be deleted and data will be stored in the first block. In the rotate mode, not all data will be deleted, but blocks will be overwritten one by one.
- When you select the trigger mode to be "free", and you start data capturing by pressing the MEMORY START/STOP-key, data capture will start immediately. However, when trigger conditions are set, it might take some time before actual data capture will start.

# Triggering

This chapter describes the way to set the trigger settings to trigger real-time recording, data capture or chart speed change.

## 6.1 Initial Settings and Overview

This section gives an overview of the settings related to triggering.

### What You Should Know

You can set a variety of trigger conditions to trigger real-time recording, data capture or chart speed change.

#### Initial Settings

Trigger screen (Press the MENU-key and select #4)\*

Parameter	Description	Values
Trigger	Selects the type of trigger	Window, All-CH, Ext.
Action	Selects the action after triggering: real-time recording, data capture, or change of chart speed	Memory, Record, Chart Speed
Mode	Selects the trigger mode	Single, Repeat, Free, Repeat seq., Repeat rotate
Delay	Selects pre- or post-trigger	-100 to 1000%
AND/OR	Selects AND or OR	AND, OR
CH	Selects the channel for triggering Selects channel for triggering in case of logic input	Off, CH1, CH2, ..., CH8 Off, CH A, CH B
Slope	in case of Window type: Selects leading or trailing edge, high or low in case of Channel type: Selects off, leading, trailing edge, high or low in case of Ext type: Selects leading edge or trailing edge	Rise, Fall, High, Low Off, Rise, Fall, High, Low Rise, Fall
Level	Sets the trigger level	0%, -100 to 100%
Logic	Selects the level for logic trigger	1, 0, x

**Trigger Type Window**

This selection allows you to enter up to four conditions (two in case of logic input), where it is possible to enter more than one condition for the same channel.

**All Channels**

This selection allows you to enter one condition for each individual channel.

**External**

This selection is used when external control signals are used. You can choose between leading-edge signals (rise) and trailing-edge signals (fall).

**Action**

**Memory**

This selection allows you to start capturing data when the trigger conditions are met.

**Record**

This selection allows you to start recording when the trigger conditions are met.

**Chart Speed**

This selection allows you to change the chart speed when the trigger conditions are met.

**Mode**

The selectable settings here depend on the selected action (Memory, Record or Chart Speed). When the action is set to "Record", refer to 6.4.1. When the action is set to "Memory", refer to 6.4.2. When the action is set to "Chart speed", there is no need for a mode setting. Refer to page 6-3.

**AND/OR Trigger**

**AND**

This lets you start recording when the trigger conditions (source channel, slope and level) for all selected channels are met.

**OR**

This lets you start recording when the trigger conditions (source channel, slope and level) for any one of the selected channels are met.

**Slope**

This lets you select either a leading-edge (rise), trailing-edge (fall), low-level (low) or high-level (high) trigger.

**Trigger Level**

This lets you select the threshold level for percentage (between -100 and 100) of the measurement range setting value.

Voltage (V) or temperature (°C) is displayed with the percentage.

**6.2 Selecting the Trigger Type**

This section describes how to select the appropriate trigger type.

**What You Should Know**

There are three types of triggers you can choose from:

**Window**

This selection is useful when you want to set more than one trigger condition for the same channel. You can set up to four conditions (up to two in case of logic input) when selecting this trigger type.

The display looks as follows:

Trigger : Window		Window
Action	: Memory	Ext.
Mode	: Free	
Delay	: 0% ( 0ms)	
AND/OR	: OR	
Condition		
No	CH	Slope
1	Off	
2	Off	
3	Off	
4	Off	
Logic		
No	CH	1 2 3 4 5 6 7 8
1	Off	
2	Off	

**All Channels**

This selection is useful when you want to set one trigger condition for each individual channel.

The display looks as follows:

Trigger : All Channels		Window
Action	: Memory	Ext.
Mode	: Free	
Delay	: 0% ( 0ms)	
AND/OR	: OR	
CH1	: Rise	5% [ 0.50 ]
CH2	: High	-5% [ -0.50 ]
CH3	: Fall	-10% [ -1.00 ]
CH4	: Off	
CH5	: Off	
CH6	: Off	
CH7	: Off	
CH8	: Off	
Channel No.	Trigger condition	

**External**

This selection is useful when you want to trigger in response to an external control signal. When selecting external, be sure to input the external signal at the EXT INPUT/OUTPUT connector.

The display looks as follows:

Trigger : External		Window
Action	: Memory	Ext.
Mode	: Free	
Delay	: 0% ( 0ms)	
Slope	: Rise	
All-CH		

## Operating Procedure

- 1 Press the MENU-key.
- 2 Select "#4 Trigger" using the soft keys.
- 3 The cursor will be on the "Trigger" setting. Select from "Window," "Ext." or "All-CH" using the soft keys.
- 4 The setting screen will change accordingly. In case you made a mistake, you can easily correct this by moving the cursor to the "Trigger" setting again and selecting the correct type of trigger.

## 6.3 Selecting the Trigger Action

This section describes how to select the trigger action.

### What You Should Know

There are three types of action you can choose from:

#### Memory

This selection is used when you want to start data capturing when the trigger conditions are met.

#### Record

This selection is used when you want to start real-time recording when the trigger conditions are met.

#### Chart Speed

This action is valid in case of real-time recording only. When a trigger occurs, the chart speed will change to a second, preset, value. After that, every second the trigger will be verified and the second chart speed will stay valid until the trigger conditions are not met anymore. Therefore, the delay between the time the trigger conditions are not met anymore and the time the chart speed changes back again is maximum one second. Refer to the figure below.

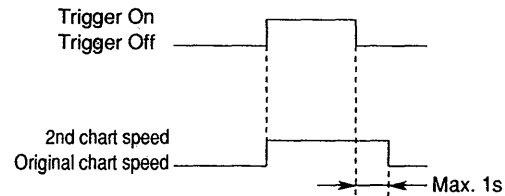

Note that you cannot select chart speeds with the unit "mm/h" for this chart speed.

### Operating Procedure

Continuing from the "Trigger" setting (6.2)...

- 1 Move the cursor onto the "Action" setting, if necessary.
- 2 Select the required action.

Trigger : Window		Memory
Action Mode	Free	Record
Delay	OR % ( 0ms)	
AND/OR		
Condition		Chart speed
No CH	Slope Level	
1	Off	
2	Off	
3	Off	
4	Off	
Logic		
No CH	1 2 3 4 5 6 7 8	
5	Off	
6	Off	

#### NOTES

- When the trigger action is set to "Record", data capture is not available during real-time recording.
- When the trigger action is set to "Chart speed" and a trigger occurs very soon after real-time recording starts, then the old chart speed might be printed.

## 6.4 Selecting the Trigger Mode

This section describes how to select the trigger mode. The selectable trigger mode depends on the action setting. When the action is set to "Chart speed", there is no trigger mode.

### 6.4.1 Selecting the Trigger Mode in Case of Triggering Real-Time Recording

This section describes the trigger mode setting in case you assigned "Record" as the trigger action.

#### What You Should Know

There are three types of modes you can choose from:

##### Free

This mode is useful when starting the recording is not related to the occurrence of any trigger. You can start the recording by pressing the RECORD START/STOP-key (see 4.2) or by external input (see 9.6).

##### Single

You can activate this mode by pressing the RECORD START/STOP-key once. When this mode is activated and the trigger conditions are met, recording will start. To stop recording, press the RECORD START/STOP-key again. When you selected single-shot recording as well (see 4.15), the recording will stop automatically when the chart travelled the specified length.

##### Repeat

You can activate this mode by pressing the RECORD START/STOP-key once. When this mode is activated and the trigger conditions are met, recording will start. To stop the recording, press the RECORD START/STOP-key again. When you selected single-shot recording as well (see 4.15), the recording will stop automatically when the chart travelled the specified length. Then, the "waiting for trigger" message appears. When the trigger conditions are met again, recording will start again.

#### Operating Procedure

Continuing from the "Action" setting (6.3)...

- 1 Move the cursor onto the "Mode" setting, if necessary.
- 2 Select the required mode using the soft keys. In case you made a mistake, you can easily correct this by moving the cursor to the "Action" setting again and selecting the correct type of action.

Trigger	:	Window	
Action	:	Record	Free
Mode	:	Free	Single
AND/OR	:	OR	Repeat
Condition			
No	CH	Slope	Level
1	Off		
2	Off		
3	Off		
4	Off		
Logic			
No	CH	1	2 3 4 5 6 7 8
5	Off		
6	Off		

### 6.4.2 Selecting the Trigger Mode in Case of Triggering Data Capture

This section describes the trigger mode setting in case you assigned "Memory" as the trigger action.

#### What You Should Know

There are four types of modes you can choose from:

##### Free

This mode is useful when starting data capture is not related to the occurrence of any trigger. You can start data capturing by pressing the MEMORY START/STOP-key (see 5.5) or by external input (see 9.6). In case you divided the memory into blocks, data will be stored in the next block each time you press the MEMORY START/STOP-key. When the last block has been used, all previous data will be deleted, and the next data will be stored in block one, overwriting previous data.

##### Single

You can activate this mode by pressing the MEMORY START/STOP-key once. A "waiting for trigger" status will be established. When the preset trigger conditions are met, data capture will start. In case you divided the memory into blocks, only one memory block will be filled, each time a trigger occurred.

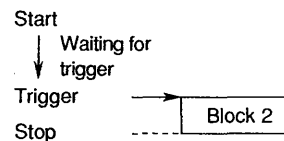
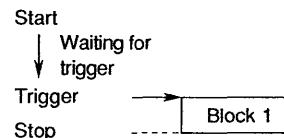

##### Repeat Sequence

You can activate this mode by pressing the MEMORY START/STOP-key once. A "waiting for trigger" status will be established. When the preset trigger conditions are met, data capture will start. In case you divided the memory into blocks, one block will be filled up every time a trigger occurs until all are full. Data capture will stop when all blocks are full, regardless whether other triggers occur.

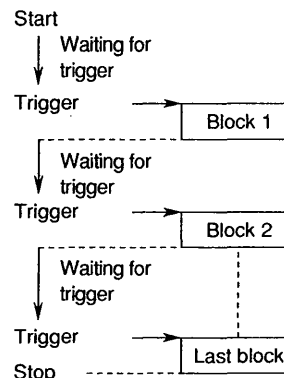

### Repeat Rotate

You can activate this mode by pressing the MEMORY START/STOP-key once. A "waiting for trigger" status will be established. When the preset trigger conditions are met, data capture will start. In case you divided the memory into blocks, one block will be filled up every time a trigger occurs until all are full. When all blocks are full and a next trigger occurs, block one will be overwritten. When a next trigger occurs, block two will be overwritten, etc..

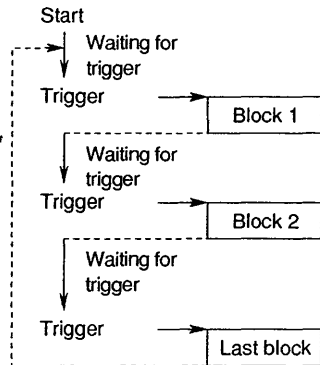

### NOTE

When waiting for trigger, the following block will already be emptied.

### Operating Procedure

Continuing from the "Action" setting (6.3)...

- 1 Move the cursor onto the "Mode" setting, if necessary.
- 2 Select the required mode using the soft keys. In case you made a mistake, you can easily correct this by moving the cursor to the "Action" setting again and selecting the correct type of action.

Trigger : Window		Free							
Action	Memory	Single							
Mode	Free	Repeat Sequence							
Delay	0% ( 0ms)	Repeat Rotate							
AND/OR	OR								
Condition									
No	CH	Slope	Level						
1	Off								
2	Off								
3	Off								
4	Off								
Logic									
No	CH	1	2	3	4	5	6	7	8
0	On	Off							
1	Off								

You can also change the trigger mode while recording is in progress. Note that this setting only affects the trigger mode in case of data capturing.

- 1 Press the MENU-key.
- 2 Select "#4 Trigger" using the soft keys.
- 3 Select the required trigger mode using the soft keys.

Trigger		Free
Mode	Repeat Sequence	Single
		Repeat Sequence
		Repeat Rotate

## 6.5 Setting Pre- or Post-Trigger Conditions

This section describes how to select the portion of memory available for storing data sampled before a trigger event occurs.

### What You Should Know

#### Pre-Trigger Setting

A pre-trigger can only be set in case the trigger action is set to "Memory".

When you press the MEMORY START/STOP-key, data capture starts immediately, regardless of the trigger conditions you have set. Consequently, you can record sampled data even before a trigger event occurs. This is called pre-trigger recording.

You set the memory length reserved for pre-trigger recording as a percentage (-100 to 0%) of the total memory length in multiples of 1%.

in formula:

the number of pre-trigger data = number of sampled data x pre-trigger (%)

#### Example

Assume you have set the following parameters.

Sample rate : 1kHz  
 Memory length : 1kdata  
 Number of memory blocks : 1  
 Pre-trigger : -10%

When a trigger event occurs, sampled data will be stored in memory as follows:

data sampled before the trigger 100data covering a 0.1s period  
 data sampled after the trigger 900data covering a 0.9s period.

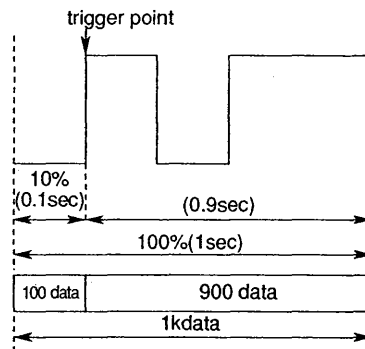

### NOTE

When you set the percentage for pre-trigger data and then press the MEMORY START/STOP-key, data is sampled and stored in that part of memory allocated for pre-trigger only. During the period this pre-trigger data is stored, the trigger conditions are ignored (the TRIGGER READY display LED remains off). Only when the memory for pre-trigger data is full, the trigger conditions become active (the TRIGGER READY display LED turns on). When you stop capturing by pressing the MEMORY START/STOP-key before the waiting for trigger status occurs, captured data cannot be retrieved.

### Post-Trigger Setting

A post-trigger can only be set in case the trigger action is set to "Memory". When using a post-trigger, a data sample will be taken after a certain time elapsed after the trigger. By setting the post-trigger, you specify the time delay before data sampling will start. You set the post-trigger as a percentage of the total memory length (0 to 1000%).

in formula:

$$\text{post-trigger delay} = \text{total memory length} \times \text{post-trigger} (\%)$$

### Example

Assume you have set the following parameters.

Sample rate : 1kHz  
 Memory length : 1kdata  
 Number of memory blocks : 1  
 Post-trigger : 80%

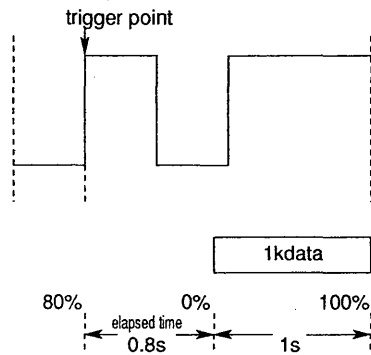

### Operating Procedure

Continuing from the "Mode" setting (6.4)... Note that "Memory" must be set for "Action" (6.3).

- 1 Move the cursor onto the "Delay" setting, if necessary.
- 2 Select the required delay using the rotary knob. You are setting a pre-trigger by setting any percentage of -100% to 0%. You are setting a post-trigger by setting any percentage of 0% to 1000%.

Trigger : Window	
Action	Memory
Mode	Free
Delay	0% ( 0ms )
AND/OR	OR

①

Condition			
No	CH	Slope	Level
1	CH1	Rise	0% [ 0mV 0.00U ]
2	Off		
3	CH4	Rise	0% [ 0.00U ]
4	Off		

Logic									
No	CH	1	2	3	4	5	6	7	8
5	Off								
6	Off								

① Time corresponding to the pre-trigger data or post-trigger delay.

## 6.6 Selecting AND/OR Triggering

This section describes how to select AND/OR trigger conditions.

### What You Should Know

#### AND Triggering

You can start recording or data capture when the trigger conditions (to be specified in 6.7) for all selected waveforms are met. Note that the number of waveforms which can be selected depends on the trigger type (up to four in case of "Window" type and up to 8 in case of "All channels" type, see 6.2) and whether logic input channels are being installed (an extra two).

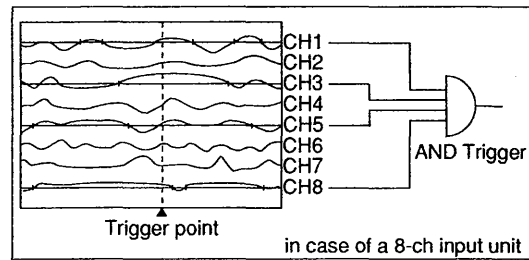

#### OR Triggering

You can start recording when the trigger conditions (to be specified in 6.7) for any one of the selected waveforms are met. Note that the number of waveforms which can be selected depends on the trigger type (up to four in case of "Window" type and up to 8 in case of "All channels" type, see 6.2).

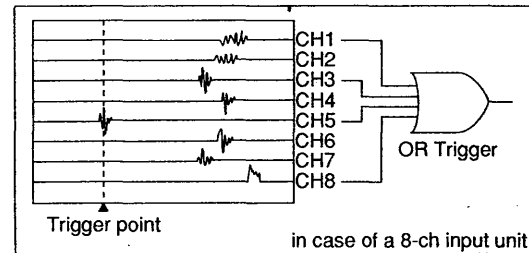

### NOTE

If you select only one trigger condition, the trigger logic is identical for both AND and OR triggering.

### Operating Procedure

Continuing from the "Mode" setting (6.4)...

- 1 Move the cursor onto the "AND/OR" setting, if necessary.
- 2 Select "AND" or "OR" using the soft keys. In case you made a mistake, you can easily correct this by moving the cursor to the "AND/OR" setting again and selecting again.

Trigger : Window	
Action	Memory
Mode	Free
Delay	0% ( 0ms )
AND/OR	OR

Condition			
No	CH	Slope	Level
1	CH1	Rise	0% [ 0mV 0.00U ]
2	Off		
3	CH4	Rise	0% [ 0.00U ]
4	Off		

Logic									
No	CH	1	2	3	4	5	6	7	8
5	Off								
6	Off								

## 6.7 Setting Trigger Conditions

This section describes how to select trigger conditions such as source channels, trigger slope and level. These settings are all located in the lower hand of the "Trigger" screen.

### What You Should Know

The screen to enter the trigger conditions depends on the type of trigger (see 6.2). One of the following two screens may appear:

#### Trigger Window

```

Trigger : Window
Action   : Memory
Mode     : Free
Delay    : 0% ( 0ms)
AND/OR   : OR

Condition
No CH    Slope  Level
1 CH1    Rise   0%[ 0mU 0.00U]
2 CH2    Off    0%[ 0mU 0.00U]
3 CH3    Rise   0%[ 0mU 0.00U]
4 CH4    Off    0%[ 0mU 0.00U]

Logic
No CH    1 2 3 4 5 6 7 8
1 CH1    Off Off
2 CH2    Off Off
3 CH3    Off Off
4 CH4    Off Off

Trigger slope
source channel Trigger level
    
```

#### Trigger All Channels

```

Trigger : All Channels
Action   : Record
Mode     : Repeat
AND/OR   : AND

CH1 : Off 5%[ 5m 0.00U]
CH2 : Off 5%[ 5m 0.00U]
CH3 : Off 5%[ 5m 0.00U]
CH4 : Off 5%[ 5m 0.00U]
CH5 : Off 5%[ 5m 0.00U]
CH6 : Off 5%[ 5m 0.00U]
CH7 : Off 5%[ 5m 0.00U]
CH8 : Off 5%[ 5m 0.00U]

Off
Rise
Fall
High
Low

Trigger slope
Source channel Trigger level
    
```

#### Source Channels

You select source channels you want to include in AND/OR triggering. See also 6.6.

#### Slope

You can select the trigger to be activated in case of the following input states:

##### Rise

Trigger will be activated at the leading edge of a signal.

##### Fall

Trigger will be activated at the trailing edge of a signal.

##### High

Trigger will be activated when the signal level is higher than the set level (not for external trigger).

##### Low

Trigger will be activated when the signal level is lower than the set level (not for external trigger).

#### Trigger Level

You can set the trigger level to a percentage of the measurement range between -100 and 100% in 1% increments, by turning the rotary knob.

In case of voltage input, the trigger level can be designated as "-100 to 100%", regardless of the measurement range.

In case of thermocouple input, the trigger level varies according to the type, as shown in the table below.

This is to permit level setting where the measurement range upper limit is +100% with a minus value of -100% (for example, K-type thermocouple where -1300°C is -100%; -1300°C however is not available, so the minimum value will become approx. -15% which corresponds with -200°C). The table below shows the permissible setting ranges of the trigger levels and the value per 1% increment.

#### Permissible Setting Ranges for Thermocouple Inputs

Measurement Range	Actual Measurement Range	Setting Range of Trigger Level	Temperature per 1%
K	-200.0 to 1300.0°C	-15% to 100%	13.0°C
J	-200.0 to 1100.0°C	-18% to 100%	11.0°C
E	-200.0 to 800.0°C	-25% to 100%	8.0°C
T	-200.0 to 400.0°C	-50% to 100%	4.0°C
L	-200.0 to 900.0°C	-22% to 100%	9.0°C
U	-200.0 to 400.0°C	-50% to 100%	4.0°C
R	0.0 to 1700.0°C	0% to 100%	17.0°C
S	0.0 to 1700.0°C	0% to 100%	17.0°C
B	0.0 to 1800.0°C	0% to 100%	18.0°C
N	0.0 to 1300.0°C	0% to 100%	13.0°C
W	0.0 to 2300.0°C	0% to 100%	23.0°C

#### NOTE

When you set the trigger slope in combination with the AND trigger, and two or more conditions are designated for a RISE or FALL setting, there is a high possibility that the trigger will not be activated. This is because it is extremely unlikely that the RISE and FALL conditions will be met simultaneously.

#### Trigger Point Error

Depending on the measurement data reception timing, a slight discrepancy occurs between the designated trigger activation time and the actual trigger activation time, as illustrated in the figure below. This is particularly noticeable when the sample rate is low.

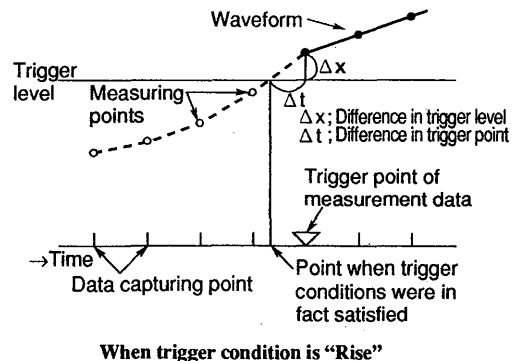



## Operating Procedure

Continuing from the "AND/OR" setting (6.6) and assuming to work within the "Window" trigger screen...

- 1 Move the cursor to any "CH" setting and select the number of the source channel. The cursor moves to the "Slope" setting.
- 2 Select the required setting using the soft keys. The cursor moves to the "Level" setting.
- 3 Set the level using the rotary knob. Pressing the (left) cursor key moves the cursor to the most significant digit of the current setting. Turning the rotary knob results in changing the setting in increments of 10%.
- 4 Repeat step 1 to 3 for all required source channels.

Trigger : Window									
Action Mode	:	Memory							
Delay	:	Freq							
AND/OR	:	OR							
-----									
Condition									
No	CH	Slope	Level						
1	CH1	Rise	0% [ 0mU 0.00U ]						
2	Off	Off							
3	CH4	Rise	0% [ 0mU 0.00U ]						
4	Off	Off							
-----									
Logic									
No	CH	1	2	3	4	5	6	7	8
5	Off								
6	Off								

Trigger slope  
Source channel    Trigger level

Continuing from the "AND/OR" setting (6.6) and assuming to work within the "All Channels" trigger screen...

- 1 Move the cursor to any "Slope" setting (most left one in the condition block) and select the required slope setting (or off) using the soft keys. By this setting, you also select which channel is on or off.
- 2 Move the cursor to the "Level" setting and set the level using the rotary knob. Pressing the (left) cursor key moves the cursor to the most significant digit of the current setting. Turning the rotary knob results in changing the setting in increments of 10%.
- 3 Repeat step 1 and 2 for all the required source channels.

Trigger : All Channels				
Action Mode	:	Record Repeat		
AND/OR	:	AND		
-----				
CH1	:	Off	5% [ 5m 0.00U ]	Off
CH2	:	Off		
CH3	:	Fall	-5% [ -0.5U ]	Fall
CH4	:	High	10% [ 1.0U ]	High
CH5	:	Low	-15% [ -1.5U ]	Low
CH6	:	Off		
CH7	:	Off		
CH8	:	Off		

Trigger slope  
Source channel    Trigger level

### Points to note in case when setting the trigger conditions for frequency inputs

When setting the measurement range, an input filter will automatically be assigned. Therefore, accurate measurement cannot be performed outside this measurement range. (Refer to page 1-2 for the relation between cutoff freq. and meas. range).

## 6.8 Setting Window and Bi-Slope Triggering

This section tells you how to set window and bi-slope trigger conditions using AND or OR logic triggering.

### What You Should Know

#### Window triggering using AND logic

You can use this setting to activate a trigger when the measurement input signal level is higher than preset trigger level 1 and lower than preset trigger level 2 (where level 1 is lower than level 2).

#### Example

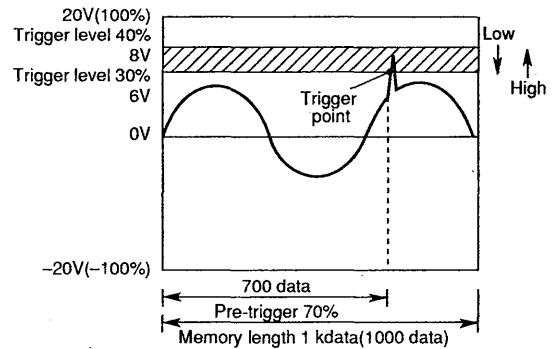

#### Window triggering using OR logic

You can use this setting to activate a trigger when the measurement input signal level is lower than preset trigger level 1 or higher than preset trigger level 2 (where level 1 is lower than level 2).

#### Example

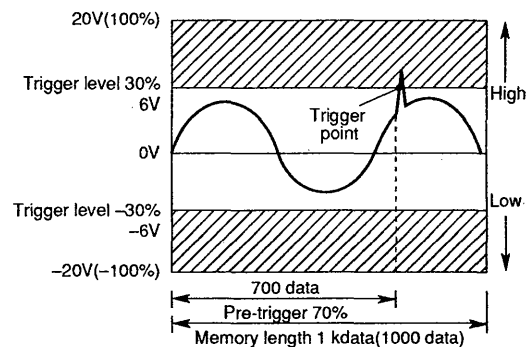

#### Bi-slope triggering using OR logic

You can use this setting to activate a trigger when the measurement input signal level falls below preset trigger level or rises above preset trigger level.

#### Example

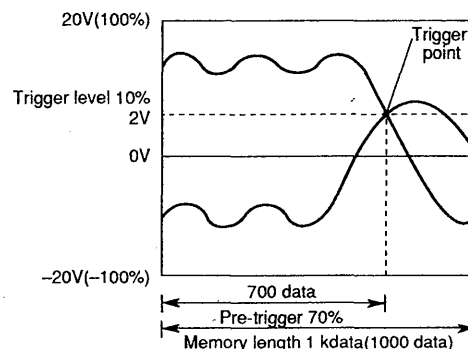

## Operating Procedure

### Window triggering

- 1 Press the MENU-key.
- 2 Select "#4 Trigger" using the soft keys. It is assumed that you are working within the "Window" trigger screen (see 6.2).
- 3 Move the cursor onto the "AND/OR" setting.
- 4 Select either "AND" or "OR" using the soft keys. The cursor moves to the "CH" setting position.
- 5 Press the soft key corresponding to the required source channel. The cursor moves to the "Slope" setting.
- 6 Press the "High" soft key to set the slope for trigger level 1. The cursor moves to the "Level" setting.
- 7 Set level 1 by turning the rotary knob.
- 8 Repeat steps 5 to 7 to set level 2. Note that you select "Low" in step 6.

Trigger : Window									
Action	Memory								
Mode	Free								
Delay	0% ( Ext. )								
AND/OR	AND								
Condition									
No	CH	Slope	Level						
1	CH1	High	20%L	2.0U ]					
2	Off								
3	CH4	Low	8%L	0.0U ]					
4	Off								
Logic									
No	CH	1	2	3	4	5	6	7	8
5	Off								
6	Off								

## Operating Procedure

### Bi-slope triggering

- Perform steps 1 to 3 as described under "Window triggering"
- 4 Select "OR" using the soft keys. The cursor moves to the "CH" setting position.
  - 5 Press the soft key corresponding to the required source channel. The cursor moves to the "Slope" setting.
  - 6 Press the "Rise" soft key to set the slope for trigger level 1. The cursor moves to the "Level" setting.
  - 7 Set level 1 by turning the rotary knob.
  - 8 Repeat steps 5 to 7 to set level 2. Note that you select "Fall" in step 6.

## 6.9 Logic Trigger

This section describes how to handle logic trigger settings.

### What You Should Know

You can input up to two logic input channels, channel A and B, within the Trigger Window screen (see 6.2). The logic input connector is of the 8-pin type. Therefore on the screen and chart 8 input channels will be shown (A1 to A8 and B1 to B8).

By the setting described here you specify the condition of all eight bits for a trigger occurrence. You can select from the following conditions:

- x "don't care"; this bit will be ignored
- 1 the value of this bit is "1", high
- 0 the value of this bit is "0", low

Logic triggering can be set when the trigger setting is set to "window".

In case of AND: when all 8 conditions are met, a trigger will occur.

In case of OR: when any one of the 8 conditions is met, a trigger will occur.

### Operating Procedure

- 1 Press the MENU-key.
- 2 Select "#4 Trigger" using the soft keys.
- 3 Move the cursor to the "CH" setting within the Logic setting section.
- 4 Select the source channel using the soft keys. Selectable from "Off", "CH-A" or "CH-B". The cursor moves to the condition setting position for bit 1.
- 5 Press the soft key corresponding to the required condition for bit1. Selectable from "0", "1" and "x" (don't care). The cursor moves to the condition setting for bit2.
- 6 Repeat this until the conditions for all bits are set.
- 7 If required, steps 4 to 6 for a second source channel.

Trigger : Window									
Action	Record	0							
Mode	Repeat								
AND/OR	AND	1							
Condition									
No	CH	Slope	Level						
1	CH1	Rise	0%L	0.0U 0.00U ]					
2	Off								
3	CH4	Rise	0%L	0.0U ]					
4	Off								
Logic									
No	CH	1	2	3	4	5	6	7	8
5	CH-A	x	0	1	0	1	x	1	x
6	CH-B	1	0	1	1	0	x	0	x

① bit number

# Printing and Displaying Captured Data

This chapter describes how to display captured data on the display and how to print the data onto the chart.

## 7.1 Printing Captured Data as Analog Waveforms

This section describes how to print captured data onto the chart as analog waveforms.

### What You Should Know

The printing of captured data will occur according to the settings you entered for real-time recording. Since the setting procedures are exactly the same as those for real-time recording, see the relevant sections in chapter 4. The settings are listed below.

The printing can be started by pressing the MEMORY PRINT-key. The corresponding LED will light. The printing will stop automatically. You can interrupt the printing by pressing the MEMORY PRINT-key again.

### NOTES

- Data capture operation is suspended during the period captured data is being printed.
- Channels with input type "off" in the Input Settings screen (displayed by pressing the CH-key) are not printed. To change this setting, refer to 3.3.1.
- Even when printing captured data, the full scale values can be changed.

Trace (T-Y) (press the MENU-key and select #1)

Parameter	Description	Section
Trace	Select whether to print a waveform and its intensity	4.10

Print Format screen (press the MENU-key and select #2)

Parameter	Description	Section
Mode	Select analog waveform	-
Format	Select the number of zones for T-Y recording, or select X-Y recording	4.4, 4.12
Grid Intensity	Select the intensity of the grid	4.5
Grid Type	Select a type of grid	4.5
Scale Print	Select whether to print the scale	4.8
Annotation	Select whether to print an annotation	4.6
Channel Print	Select whether to print the channel number and at which interval	4.7
Header	Select whether to print the date/time/chart speed or header	4.9
Flexible Zone	Select zone recording on or off, and whether to print outside its boundaries.	4.4
Assign X-Axis	Assign the horizontal axis for X-Y recording	4.12
Assign Y-Axis	Assign the vertical axis for X-Y recording	4.12

Flexible zone adjust (press the MENU-key and select #6)

Parameter	Description	Section
Zone Adjust	Select the required span of zones	4.4

### Example T-Y Recording

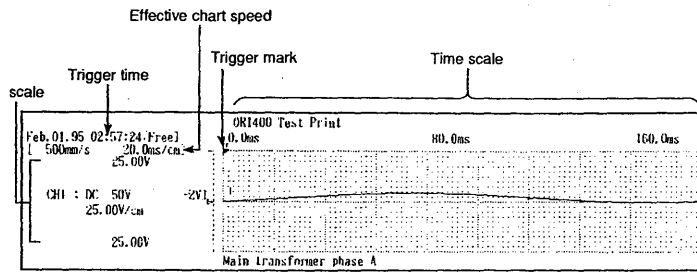

### Example X-Y Recording

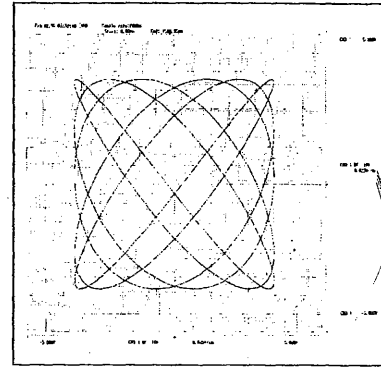

Settings which can be selected here, are:

#### Sample Rate (see 5.2)

The sample rate is the rate at which you sample and store data into memory.

#### Memory Length (see 5.3)

This setting specifies the length of the memory available for data capture per channel.

#### Number of Blocks (see 5.4)

This setting specifies the number of blocks into which the memory has been divided.

#### Auto Mode (see 7.3)

This setting specifies what will be done with the data upon termination of data capture; you can print them out, save them to the floppy disk or just capture them.

#### Calculation (see 7.7)

This setting specifies whether calculation is ON or OFF.

#### Format

This setting specifies what the format of the chart will be when printing out captured data or what the format of the data will be when saving data to the floppy disk; you can choose between strip chart (where the selected area will be recorded according to the expansion rate setting), A4 size (where the selected area will be recorded in A4 size) or A5 size (where the selected area will be recorded in A5 size). Note that when the cursor is displayed and you select a format of A5 size,

the cursor will appear on the chart too. See also 7.6.1. And, in case of 'file' you can choose from Tiff or BMP format.

#### Expansion

With this setting you specify the playback rate (in data/cm). Refer to the relation between playback rate, sample rate and effective chart speed in the table below. Note that the expansion rate is automatically decided for A4 and A5 size formats.

#### Trigger Print

With this setting you specify whether to print the time and date the trigger occurred. For an example, see the example above.

#### Block Printout (see 7.4)

If you divided the memory into blocks (see 5.4), you can specify here from which block you want to print captured data. You can select to print out all blocks, or the current only. However, when you display captured data on the screen and print out that data, then only the current (displayed) block will be printed, even when you selected all blocks here.

#### Data Retrieve (see 7.5)

With this setting you can select whether to print all data, a specified part of them, or just the displayed area. The selection "Display area" allows you to specify the area to be printed more accurately using the cursor (see page 7-6). When you select "Partial", the next setting will be from which data number to start and where to end.

Sample Rate (Hz)	Playback Rate (data/cm)							
	25	50	100	200	400	1000	2000	5000
100.000	40.0m/s	20.0m/s	10.0m/s	5.0m/s	2.5m/s	1.0m/s	500mm/s	200mm/s
50.000	20.0m/s	10.0m/s	5.0m/s	2.5m/s	1.25m/s	500mm/s	250mm/s	100mm/s
20.000	8.0m/s	4.0m/s	2.0m/s	1.0m/s	500mm/s	200mm/s	100mm/s	40mm/s
10.000	4.0m/s	2.0m/s	1.0m/s	500mm/s	250mm/s	100mm/s	50mm/s	20mm/s
5000	2.0m/s	1.0m/s	500mm/s	250mm/s	125mm/s	50mm/s	25mm/s	10mm/s
2000	800mm/s	400mm/s	200mm/s	100mm/s	50mm/s	20mm/s	10mm/s	4mm/s
1000	400mm/s	200mm/s	100mm/s	50mm/s	25mm/s	10mm/s	5mm/s	2mm/s
500	200mm/s	100mm/s	50mm/s	25mm/s	12.5mm/s	5mm/s	2.5mm/s	1mm/s
200	80mm/s	40mm/s	20mm/s	10mm/s	5mm/s	2mm/s	1mm/s	24mm/min
100	40mm/s	20mm/s	10mm/s	5mm/s	2.5mm/s	1mm/s	30mm/min	12mm/min
50	20mm/s	10mm/s	5mm/s	2.5mm/s	1.25mm/s	30mm/min	15mm/min	6mm/min
20	8mm/s	4mm/s	2mm/s	1mm/s	30mm/min	12mm/min	6mm/min	2.4mm/min
10	4mm/s	2mm/s	1mm/s	30mm/min	15mm/min	6mm/min	3mm/min	1.2mm/min
5	2mm/s	1mm/s	30mm/min	15mm/min	7.5mm/min	3mm/min	1.5mm/min	36mm/h
2	48mm/min	24mm/min	12mm/min	6mm/min	3mm/min	1.2mm/min	36mm/h	14.4mm/h
1	24mm/min	12mm/min	6mm/min	3mm/min	1.5mm/min	36mm/h	18mm/h	7.2mm/h
0.5	12mm/min	6mm/min	3mm/min	1.5mm/min	45mm/h	18mm/h	9mm/h	3.6mm/h
0.2	4.8mm/min	2.4mm/min	1.2mm/min	36mm/h	18mm/h	7.2mm/h	3.6mm/h	1.44mm/h
0.1	2.4mm/min	1.2mm/min	36mm/h	18mm/h	9mm/h	3.6mm/h	1.8mm/h	0.72mm/h

## NOTES

• The OR1400 records 20 dots/mm (8 dots/mm in case of A5). Since these settings cannot be changed, it may happen that when you select A4 or A5 size format together with a section of captured data, the recording may not fill up the whole A4 or A5 space.

### Chart speed for printing out captured data

The chart speed is 50 mm/s, except when the format is set to 'A4', then the chart speed is as follows:  
in case of a memory length of 512 k or 1 M (at time of sampling): 25 mm/s  
in case of a memory length of 256 k or less (at time of sampling): 50 mm/s

### Relation between playback rate, sample rate and effective chart speed

When T-Y recording is executed, the effective chart speed varies according to the playback rate (expansion) and sample rate settings, as shown in the table on the previous page.

## Operating Procedure

- 1 Press the MENU-key.
- 2 Select "#3 Memory format" using the soft keys. Note that the actual selection to print analog waveforms or digital data is made in the "#2 Print format" screen.
- 3 Move the cursor to the "Format" setting.
- 4 Select the required format using the soft keys. When "Strip chart" is selected, the cursor will move to the "Expansion" setting. Otherwise, the cursor moves to the "Trigger print" setting.  
When "file" is selected, the cursor will move to the "File format setting".
- 5 In case of "Strip chart": select the required expansion (playback rate) using the soft keys. If necessary, use the "-Next-" soft key to display other expansion settings. The cursor will move to the "Trigger print" setting.  
In case of "File": select the data format in which the data will be saved to the floppy disk.
- 6 Select whether to print the time the trigger occurred using the soft keys. If you have divided the memory into blocks, the cursor will move to the "Block printout" setting.
- 7 Select whether to retrieve data from all blocks, or from the current block only by using the soft keys. The cursor will move to the "Data retrieve" setting. See also 7.4.
- 8 Select whether to print all data in the memory, print the data partially or the displayed area. See also 7.5.
- 9 You can start printing by pressing the MEMORY PRINT-key.

Memory format	Strip chart
Sample rate : 50kHz	Page (A4)
Memory length : 1k ( 20.0ms)	Page (A5)
No. of blocks : 1	File
Playback conditions	
Auto mode : Off	
Calculation : Off	
Format : File	
Expansion : 100 [Data/cm]	
Trigger Print : On	
Block Printout : Current only	
Data retrieve : Total	

## 7.2 Printing Captured Data as Numeric Values

This section describes how to print captured data onto the chart as numeric values.

### What You Should Know

The printing of captured data will occur according to the settings you entered for real-time recording. Since the setting procedures are exactly the same as those for real-time recording, see the relevant sections in chapter 4.

Select "Mode: Digital" at the Print Format screen (press the MENU-key and select #2)

Settings which can be selected here, are:

#### Sample Rate (see 5.2)

The sample rate is the rate at which you sample and store data into memory.

#### Memory Length (see 5.3)

This setting specifies the length of the memory available for data capture per channel.

#### Number of Blocks (see 5.4)

This setting specifies the number of blocks into which the memory has been divided.

#### Auto Mode (see 7.3)

This setting specifies what will happen with the captured data; you can print them out, save them to the Floppy disk or just capture them.

#### Calculation (see 7.7)

This setting specifies whether calculation is ON or OFF.

#### Data Skip

This setting specifies the increment between data samples. When you select a data skip of 1, all data samples will be printed. When you select a data sample of 5, every 5th data sample is printed starting from the first data sample (thus 1st, 6th, 11th, etc.).

#### Block Printout (see 7.4)

If you divided the memory into blocks (see 5.4), you can specify here from which block you want to print captured data. You can select to print out all blocks, or the current only. However, when you display captured data on the screen and print out that data, then only the current (displayed) block will be printed, even when you selected all blocks here.

#### Data Retrieve (see 7.5)

With this setting you can select whether to print all data, a specified part of them, or just the displayed area. The selection "Display area" allows you to specify the area to be printed more accurately using the cursor (see page 7-6). When you select "Partial", the next setting will be from which data number to start and where to end.

## NOTES

- Data capture operation is suspended during the period captured data is being printed.
- Channels with input type "off" in the Input Setting screen (displayed by pressing the CH-key) are not stored into memory and therefore not printed. To change this setting, refer to 3.3.1.
- While data is being output from the memory, it is impossible to store data into memory.

Example	Numeric Value Printout		
	10	0.16	-0.002
	9	0.16	0.005
	8	0.16	-0.002
	7	0.16	-0.002
	6	0.16	-0.002
Data number	5	0.16	-0.002
	4	0.16	0.005
	3	0.16	-0.002
	2	0.16	-0.002
	1	0.16	-0.002
	0	0.16	-0.002

Occurred trigger	Data No	[mV ]	[V ]
		CH1	CH3
		Jul. 10. 93 21:30:43 [Free]	Sample

When the logic option is ON, logic data will be printed on the right side.

## Operating Procedure

- 1 Press the MENU-key.
- 2 Select "#3 Memory format" using the soft keys. Note that the actual selection to print analog waveforms or digital data is made in the "#2 Print format" screen.
- 3 Move the cursor to the "Data skip" setting.
- 4 Select the required increment using the soft keys. If necessary, select "-Next-" to display other available settings. If you have divided the memory into blocks, the cursor will move to the "Block printout" setting.
- 5 Select whether to retrieve data from all blocks, or from the current block only by using the soft keys. The cursor will move to the "Data retrieve" setting. See also 7.4.
- 6 Select whether to print all data in the memory, print the data partially or the displayed area. See also 7.5.
- 7 You can start printing by pressing the MEMORY PRINT-key.

Memory format	1
Sample rate : 50kHz	
Memory length : 1k (20.0ms)	
No. of blocks : 1	2
Playback conditions	5
Auto mode : Off	
Calculation : Off	10
Data skip : █	20
Block printout : Current only	
Data retrieve : Total	
	-Next-

## 7.3 Printing Captured Data by the Auto Mode Function

This section describes the Auto mode setting, which specifies what will be done with the data upon termination of data capture.

### What You Should Know

The Auto mode setting allows you to combine data capture and displaying/printing or saving (the results of statistical computations) to the Floppy disk automatically. For saving to the Floppy disk, refer to 8.5.

When data capture finishes, the recorder automatically prints or saves the data and then returns to the mode that was previously active when you started this function.

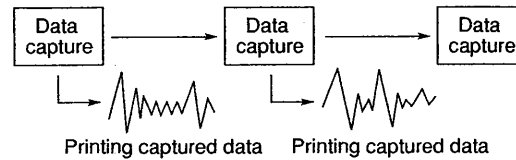

The data capture settings are selected in the normal way on the "#3 Memory condition" screen and the "#4 Trigger" screen. However, note the following differences:

- If you have divided the memory into blocks, the recorder prints out the data from each memory block immediately after it is full.
- If you have selected one of the repeat trigger modes, the recorder starts capturing data each time the trigger conditions are met and then prints the data when data capture finishes.

When printing out is selected, the printing will occur according to the settings you entered for real-time recording. Refer to the relevant sections in chapter 4.

### NOTE

When using the Auto mode function, the "Block printout" and "Data retrieve" settings will be ignored. Always the current block only will be printed.

## Operating Procedure

- 1 Press the MENU-key.
- 2 Select "#3 Memory format" using the soft keys.
- 3 Move the cursor to the "Auto mode" setting and select "Print" using the soft keys.
- 4 Press the MEMORY-key to start.

Memory format	Off
Sample rate : 50kHz	
Memory length : 1k (20.0ms)	
No. of blocks : 1	Print
Playback conditions	FD
Auto mode : <input checked="" type="checkbox"/>	
Calculation : Off	Display
Format : Strip chart	
Expansion : 100 [Data/cm]	
	(5.0ms)
Trigger print : On	Accum.
Block printout : Current only	
Data retrieve : Total	
	-Next-

## 7.4 Printing Captured Data Blocks

This section describes how to select whether to print the contents of all blocks or just the current block. However, this selection is only available when you divided the memory into blocks (see 5.4).

### What You Should Know

If you divided the available memory into blocks, you can print captured data from either the current block or from all blocks.

It is also possible to print a section of captured data from either all blocks or the current block only (see 7.5).

You can also print the captured data from any selected block.

#### All blocks

You can print the captured data from all blocks. When printing onto the chart, an interval of 30mm is inserted between blocks to distinguish the data.

#### Current only

You can print the captured data from the current block only. The current block is the block which is displayed on the Data Capture Playback screen (which appears by pressing the SHIFT-key and the MEMORY PRINT-key). It is possible to change the current block at that screen.

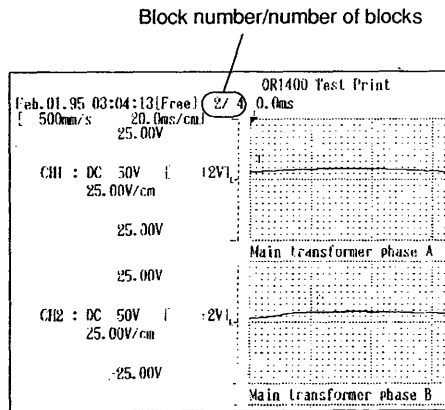

### Operating Procedure

- 1 Press the MENU-key.
- 2 Select "#3 Memory format" using the soft keys.
- 3 Move the cursor to the "Block printout" setting and select the required block setting using the soft keys.
- 4 Press the MEMORY PRINT-key to start.

Memory format		Current
Sample rate	: 50kHz	
Memory length	: 1k ( 20.0ms)	All blocks
No. of blocks	: 1	
Playback conditions		
Auto mode	: Off	
Calculation	: Off	
Format	: Strip chart	
Expansion	: 100 [Data/cm] ( 5.0mm/s )	
Trigger Print	: On	
Block printout	: <del>Current only</del>	
Data retrieve	: Total	

### Selecting a Specific Block to Print Data from

Make sure that "Current only" is selected at the "Block printout" setting (see setting above).

- 1 Press the SHIFT-key and the MEMORY PRINT-key to display the Captured Data Playback screen.
- 2 Select "Block" using the soft keys.
- 3 Move the cursor onto the required block number.
- 4 Select "Block change" using the soft keys. You will see the data on the display.
- 5 To start printing, press the MEMORY PRINT-key.

Memory block			ESC
	Data	Time of trigger	
1:	1000 95/02/01	21:27:15	
2:	1000 95/02/01	21:27:17	Block change
3:	1000 95/02/01	21:27:19	
4:	1000 95/02/01	21:27:20	
5:	1000 95/02/01	21:27:21	
6:	1000 95/02/01	21:27:23	
7:	0	*	①
8:	0	*	②
9:	-	-	
10:	-	-	Reset
11:	-	-	
12:	-	-	
13:	-	-	
14:	-	-	
15:	-	-	
- Not exist			

- ① Still empty block  
② Not existing block

## 7.5 Selecting a Section of the Captured Data

This section describes how to select a part of the captured data for printing.

### What You Should Know

You can select a section of the captured data on the following two screens:

- Data Capture Setting screen (appears by pressing the MENU-key and selecting "#3 Memory format")
- Data Capture Playback screen (appears by pressing the SHIFT-key and MEMORY PRINT-key)

### Selecting on the Data Capture Setting screen

You can select a section of the captured data by changing the data retrieve setting from "Total" to "Partial" or "Display area".

The "Partial" setting then allows you to specify the playback range by entering the sample number where to start and where to end. The range of the data sample numbers is from zero to the total memory length minus one. For example, when the memory length setting is 1kword, the range of data samples is from 0 to 999. The data sample number from where to start should be less than or equal to the data sample number where to end.

The "Display area" setting will result in a printout of only the data which are shown on the display. It is possible to specify the starting and ending point of the data to be printed using a cursor, however you cannot specify this on this Data Capture Setting screen. It should be done on the Data Capture Playback screen and is described below.

### Selecting on the Data Capture Playback screen

You can select a section of the captured data by choosing from "Total", "Partial" or "Display area". When you select "Display area" here, the required starting point and ending point should be specified using the cursor. The cursor should be moved using the rotary knob.

When you select "Partial" here, the sample number where to start and end will be according to the settings you did on the Data Capture Setting screen, as described above. You cannot adjust these settings on this screen here.

### NOTE

When you set this playback range setting on the Data Capture Playback screen, the "Data retrieve" setting at the Data Capture Setting screen will change accordingly. This will occur even if the setting was "Total".

## Operating Procedure

### Selecting on the Data Capture Setting screen

- 1 Press the MENU-key.
- 2 Select "#3 Memory format" using the soft keys.
- 3 Move the cursor to the "Data retrieve" setting and select "Partial" using the soft keys. The cursor will move to the "First" setting.
- 4 Turn the rotary knob to set the sample number from where to start.
- 5 Move the cursor to the "Last" setting.
- 6 Turn the rotary knob to set the sample number where to stop. Remember that you can also use the cursor keys to select the digit to be adjusted.
- 7 Press the MEMORY PRINT-key to start.

Memory format	
Sample rate	: 50kHz
Memory length	: 1k (20.0ms)
No. of blocks	: 8
Playback conditions	
Auto mode	: Off
Calculation	: Off
Format	: Strip chart
Expansion	: 100 (Data/cm)
Trigger print	: On (5.0m/s)
Block printout	: Current only
Data retrieve	: Partial
First	: 0
Last	: 999

### Selecting on the Data Capture Playback screen

- 1 Press the SHIFT-key and the MEMORY PRINT-key to display the Captured Data Playback screen.
- 2 Select "Print cond." using the soft keys.
- 3 Inverse (and thus select) "Display area" using the soft keys. Note that you might have to press the corresponding soft key several times. The "First/Last" selection appears.
- 4 Use the soft keys to select whether you want to set the "First" point of the data samples or the "Last" point of the data samples.
- 5 Use the rotary knob to adjust the starting or ending point. Note that the corresponding values will be displayed at the top of the screen.
- 6 The other selections here allow you to specify the printing mode (analog or digital), the format (strip chart, A4 or A5) and the expansion rate. These selections only affect the printing result, not the display.
- 7 To start printing, press the MEMORY PRINT-key.

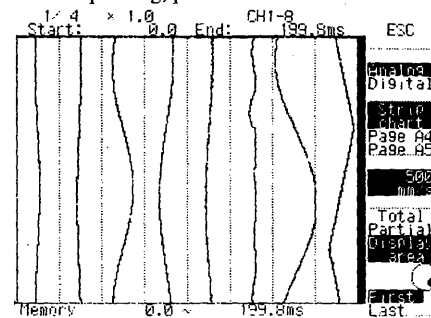



## 7.6 Displaying Captured Data on the Screen as Analog Waveforms

This section describes how to display captured data on the screen as analog waveforms.

### What You Should Know

You can display captured data on the screen as analog waveforms or numeric values.

#### Analog Waveform Screen

This screen appears by pressing the SHIFT-key and the MEMORY PRINT-key. The analog waveform display is a convenient way to check all measurement data which has been stored into memory.

The display looks as follows:

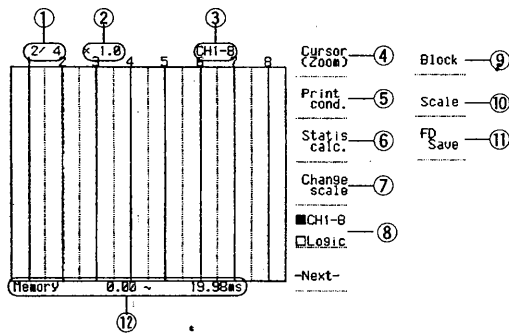

#### ① Number of the Displayed Block

You can change the displayed block by pressing the "Block" soft key. If you divided the memory into blocks, data is displayed by block, starting with the current block.

#### ② Zoom Rate

You can change the zoom rate by pressing the "Cursor (Zoom)" soft key.

#### ③ Indication of the Displayed Channels

You will find the number of the displayed channel here or, in case you are using the logic option, "CH-A, B". Note that this does not appear in case of X-Y waveforms.

#### ④ Cursor (Zoom) (see p.7-8)

Press this soft key to use the cursor function and zoom function.

#### ⑤ Printing Conditions (see p.7-6)

Press this soft key to adjust the printing conditions as mode, format and range.

#### ⑥ Statistical Calculation (see p.7-12)

Press this soft key to execute statistical computation.

#### ⑦ Change Scale

Press this soft key to change the full scale values.

#### ⑧ Channel Indication

Press this soft key to select between the display of CH1-8 or logic channels.

#### ⑨ Block (see this page)

Press this soft key to change the displayed block.

#### ⑩ Scale

Press this key to check the conditions for data capturing.

#### ⑪ FD Save (see p. 8-5)

Press this soft key to save the displayed captured data to the FDD.

#### ⑫ Memory Length

This indicates the time data capture was started and completed for the displayed data, and equals the time triggering started and stopped.

Note that in case of X-Y recordings, only the block soft key menu will appear.

Differences between displaying on the screen and recording on the chart are as follows:

- Scales for the X and Y axes, messages, channel numbers, date, time and trigger times are not displayed.
- All channels are displayed at the same trace intensity, regardless of the current trace intensity setting.
- The expansion, or playback rate, is ignored.
- When displaying by X-Y axis, the waveform of channels set to X axis and Y1 axis is displayed.

### Operating Procedure

#### Displaying captured data on the screen as analog waveforms

- 1 Press the SHIFT-key and the MEMORY PRINT-key. The captured data will appear on the screen as analog waveforms, which looks as the figure below.

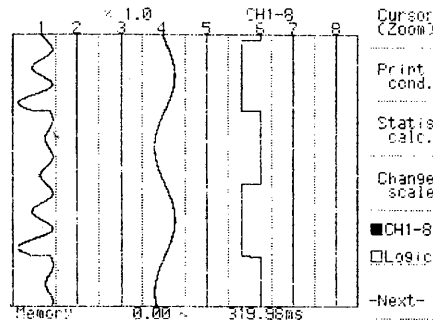

#### Displaying a specific block on the screen as analog waveforms

- 1 Press the SHIFT-key and the MEMORY PRINT-key. The captured data will appear on the screen as analog waveforms.
- 2 Press the NEXT soft key and select "Block".
- 3 Move the cursor to the block number you want to display.
- 4 Once you selected the required block number, press the "Block change" soft key. Pressing the "ESC" soft key here, will take you to the previous display. Pressing the "Reset" soft key here, will result in emptying all blocks. Take care. The data of that block will appear on the screen.
- 5 To select an other block, repeat steps 2 to 4 again.

Memory block	Data	Time of trigger	ESC
1	1000	95/02/01 21:27:15	Block change
2	1000	95/02/01 21:27:17	
3	1000	95/02/01 21:27:19	Reset
4	1000	95/02/01 21:27:21	
5	1000	95/02/01 21:27:23	
6	---	---	
7	---	---	
8	---	---	
9	---	---	
10	---	---	
11	---	---	
12	---	---	
13	---	---	
14	---	---	
15	---	---	
16	---	---	
17	---	---	
18	---	---	
19	---	---	
20	---	---	
21	---	---	
22	---	---	
23	---	---	
24	---	---	
25	---	---	
26	---	---	
27	---	---	
28	---	---	
29	---	---	
30	---	---	
31	---	---	
32	---	---	
33	---	---	
34	---	---	
35	---	---	
36	---	---	
37	---	---	
38	---	---	
39	---	---	
40	---	---	
41	---	---	
42	---	---	
43	---	---	
44	---	---	
45	---	---	
46	---	---	
47	---	---	
48	---	---	
49	---	---	
50	---	---	
51	---	---	
52	---	---	
53	---	---	
54	---	---	
55	---	---	
56	---	---	
57	---	---	
58	---	---	
59	---	---	
60	---	---	
61	---	---	
62	---	---	
63	---	---	
64	---	---	
65	---	---	
66	---	---	
67	---	---	
68	---	---	
69	---	---	
70	---	---	
71	---	---	
72	---	---	
73	---	---	
74	---	---	
75	---	---	
76	---	---	
77	---	---	
78	---	---	
79	---	---	
80	---	---	
81	---	---	
82	---	---	
83	---	---	
84	---	---	
85	---	---	
86	---	---	
87	---	---	
88	---	---	
89	---	---	
90	---	---	
91	---	---	
92	---	---	
93	---	---	
94	---	---	
95	---	---	
96	---	---	
97	---	---	
98	---	---	
99	---	---	
100	---	---	

## 7.6.1 Displaying Data Digitally and Zooming In on Analog Waveforms

This section describes how you can display data of the analog waveform digitally and zoom in on analog waveforms.

### What You Should Know

When you use the zoom function, you will see an expanded view of the analog display around the readout cursor.

This readout cursor automatically displays the value of the cross-point of the analog waveform and the readout cursor as a numeric value. Using a reference cursor you can measure and display the difference in values and time between the readout cursor and reference cursor.

The display looks as follows:

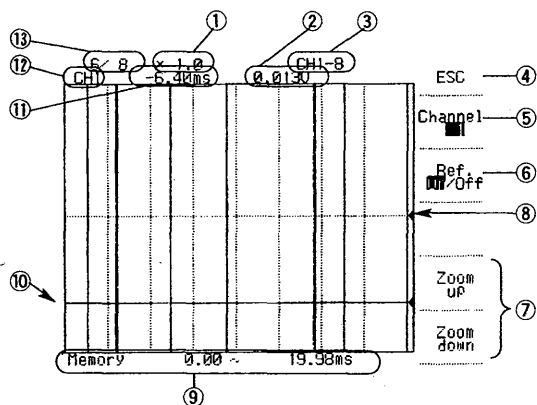

#### ①Zoom Rate

You can change the zoom rate by pressing the “Zoom Up/Down” soft keys.

#### ②Measured Value

When you are not using a reference cursor, this value corresponds to the position of the readout cursor. When you are using a reference cursor, this value indicates the difference in value between the readout cursor and the reference cursor.

#### ③Indication of the Displayed Channels

You will find the number of the displayed channel here or, in case you are using the logic option, “CH-A, B”. Note that this does not appear in case of X-Y waveforms.

#### ④ESC key

Press this soft key to return to the previous display.

#### ⑤Channel key

Press this soft key to change the channel.

#### ⑥Reference key (see p.7-9)

Use this soft key whether to select a reference cursor.

#### ⑦Zoom up/down keys

Press these soft keys to expand the display around the cursor line.

#### ⑧Readout Cursor

You can change the value of the readout cursor by turning the rotary knob or cursor keys.

#### ⑨Memory Length

This indicates the time data capture was started and completed for the displayed data, and equals the time triggering started and stopped.

#### ⑩Reference Cursor

You can select a reference cursor by using the soft key. Changing its value can be done by the rotary knob or cursor keys.

#### ⑪Time of Data Capture

When you are not using a reference cursor, this value indicates the actual time corresponding to the readout cursor. When you are using a reference cursor, this value indicates the time difference between the readout cursor and the reference cursor.

#### ⑫Channel Number

You can change the displayed channel by pressing the “Channel” soft key.

#### ⑬Block Number

If you divided the memory into blocks, this will indicate which block is being displayed.

The maximum zooming rate depends on the memory length of the captured data. See the table below.

Memory Length	Zoom Rate									
1k	5	2.5	1							
2k	10	5	2	1						
4k	20	10	4	2	1					
8k	40	20	8	4	2	1				
16k	80	40	16	8	4	2	1			
32k	160	80	32	16	8	4	2	1		
64k	320	160	64	32	16	8	4	2	1	
128k	640	320	128	64	32	16	8	4	2	1
256k	1280	640	256	128	64	32	16	8	4	1
512k	2560	1280	512	256	128	64	32	16	4	1
1M	5120	2560	1024	512	256	128	64	16	4	1

## Operating Procedure

### Displaying data as analog waveforms

- 1 Press the SHIFT-key and the MEMORY PRINT-key to display the Captured Data Playback screen.

### Displaying data corresponding to the readout cursor as a numeric value

- 2 Select "Cursor (Zoom)" using the soft keys.
- 3 Select the required channel by pressing the "Channel" soft key.
- 4 The readout cursor appears. The value corresponding to the position of the cursor already appears in the upper hand of the screen.
- 5 While moving the position of the readout cursor by turning the rotary knob, the value changes according to the new position. You can move the readout cursor more accurately by pressing the FINE-key first. You can quickly move the readout cursor using the cursor keys.

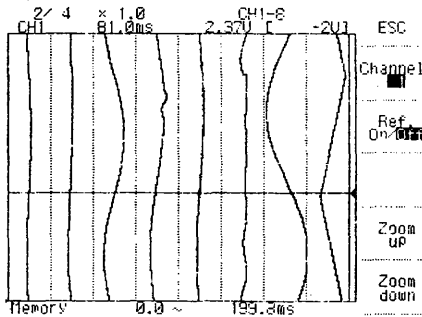

### Displaying data corresponding to the difference between reference cursor and readout cursor

- 2 Select "Cursor (Zoom)" using the soft keys.
- 3 Select the required channel by pressing the "Channel" soft key.
- 4 The readout cursor appears. Move the cursor using the rotary knob to the required reference position.
- 5 Select "On" at the "Ref. On/Off" setting using the soft keys. A reference cursor appears at the same position where the readout cursor is located.
- 6 Turning the rotary knob now will move the readout cursor while the reference cursor stays at the same position. The upper screen will indicate the difference between readout cursor and reference cursor in value and time. You can quickly move the readout cursor using the cursor keys.

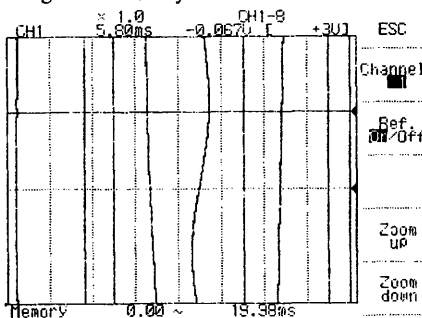

### Displaying an expanded view of the analog waveform display around the readout cursor

- 1 Press the SHIFT-key and the MEMORY PRINT-key to display the Captured Data Playback screen.
- 2 Select "Cursor (Zoom)" using the soft keys.
- 3 Select the required channel by pressing the "Channel" soft key.
- 4 The readout cursor appears. Move the readout cursor to the position of which you want to have an expanded view. You can also set the reference cursor here as explained before.
- 5 Select "Zoom up" using the soft keys. An expanded view will appear on the display. You can adjust the expanded display by using the "Zoom up" and "Zoom down" soft keys.

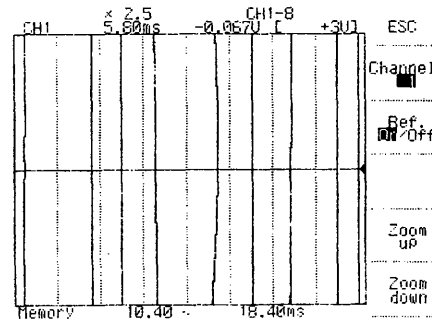

## 7.6.2 Retrieving Waveforms Using the Auto Mode Function

This section describes how to display waveforms on the screen automatically after retrieving data from the memory.

You can select to display the current block on the screen only or accumulate the retrieved blocks. The channels which will be displayed will be the same as shown on the previous monitor screen (1-8CH, Logic CH). However, when you previously used the full-scale value display, or the numerical value display, then 1-8CH will be displayed.

When using the accumulate function, the memory should be divided into blocks and the trigger should be set to "Repeat".

### NOTES

- Pressing the MEMORY START/STOP-key will result in the disappearance of all the so far displayed waveforms, even when you are using the accumulate function.
- In case the trigger is set to "Repeat rotate" and you are using the accumulate function, the block number will not be displayed, regardless the trigger condition.
- Analysis such as zooming, etc. cannot be performed on waveforms displayed using the Auto mode function.
- Nothing will be displayed while recording is in progress.

### Operating Procedure

- 1 Press the MENU-key.
- 2 Select "#3 Memory format" using the soft keys.
- 3 Move the cursor to the "Auto mode" setting.
- 4 Select "Display" or "Accumulate" using the soft keys.
- 5 Press the MEMORY START/STOP-key.

Memory format		Off
Sample rate	: 50kHz	
Memory length	: 1k	
No. of blocks	: 8 (20.0ms)	Print
Playback conditions		FD
Auto mode	: Accumulate	
Calculation	: Off	Display
Format	: Strip chart	
Expansion	: 100 [Data/cm] (5.0m/s)	Accum.
Trigger print	: On	
Block printout	: Current only	
Data retrieve	: Total	-Next-

## 7.6.3 Changing the Scale of the Waveform

This section describes how to change the full scale values of the retrieved waveform.

### NOTES

- You cannot change the full scale values of the computed data.
- You cannot change the full scale values of data saved on other equipment.
- You cannot change the full scale values in case of the X-Y display. However, changing the scales on the T-Y display will result in changed scales on the X-Y display also.

### Operating Procedure

- 1 Press the SHIFT-key and the MEMORY PRINT-key. The captured data will appear on the screen as analog waveforms.
- 2 Select "Change scale" using the soft keys.
- 3 Select the channel for which you want to change the full scale values. You can change the channel number by pressing the "Channel" soft key. (If the required channel does not appear, you may try to press the ESC-soft key and select 1-8CH or logic.)
- 4 Turning the rotary knob when the RANGE LED is lit will result in changing the full scale values. Turning the rotary knob when the POSITION LED is lit, will result in changing the recording position.
- 5 Pressing the "Scale Reset" soft key will result in resetting the full scale values to their original settings when they were captured. Pressing the "ESC" soft key will result in displaying the previous display.

Memory format		Off
Sample rate	: 50kHz	
Memory length	: 1k	
No. of blocks	: 8 (20.0ms)	Print
Playback conditions		FD
Auto mode	: Accumulate	
Calculation	: Off	Display
Format	: Strip chart	
Expansion	: 100 [Data/cm] (5.0m/s)	Accum.
Trigger print	: On	
Block printout	: Current only	
Data retrieve	: Total	-Next-

### Auto Display / Accumulate

It is possible to display waveforms automatically after each time of data capture.

Besides, using the accumulate function will result in displaying the waveforms accumulatively each time data are saved to a block.

## 7.7 How to Use the Mathematical Function

This section describes how to perform waveform computations or statistical computations on captured data.

### 7.7.1 Performing Arithmetic Computations Between Channels / Comparing Data on the Same Time Axis

It is possible to perform arithmetic computations between two channels on unprocessed, captured data. Furthermore, by specifying any blocks, data which differ on the time axis can be displayed and recorded on the same time axis.

You can select from the following five types of mathematical functions:

+, -, \*, /, : (colon is to be used for specifying blocks in case of comparing data on time series). Computations can be performed on all channels except for the optional logic channels. Besides, settings can be set ON/OFF per channel.

Computation is also possible between the measurement values of voltage and temperature (calculation of numerical value). When comparing mV and V, all data will be transferred into V.

#### Number of Blocks / Memory Length in Case of Computation

There might be cases where calculation cannot be carried out because of the corresponding settings of memory length and number of blocks. This is because in case of computation, you will use twice the substantial memory, since you are generating computational data of the same amount as the set memory length. For example, in case you set the memory length to be 64k, the setting data will utilize 64k, the calculation data will utilize 64k and the substantial memory will therefore become 128k. Refer to the figure below. Note that the memory will also contain measurement data, which can be used as normal when calculation is set to OFF.

	Memory length	Number of blocks				
		1	2	4	8	16
	1k	○	○	○	○	○
	2k	○	○	○	○	○
	4k	○	○	○	○	○
	8k	○	○	○	○	○
	16k	○	○	○	○	×
	32k	○	○	○	×	—
	64k	○	○	×	—	—
	128k	○	×	—	—	—
	256k	×	—	—	—	—
	512k	×	—	—	—	—
	1M	×	—	—	—	—

× : calculation is not possible  
 ○ : calculation is possible  
 — : setting is not possible

#### Linear Scaling

In case you set linear scaling for channels which data are to be used for computation, linear scaling of the measurement data will be done previous to computation.

In case you set linear scaling for the computation channel, linear scaling will not be done.

#### NOTES

- In case of the settings which are described as not possible in the table above, an error message will be displayed and data will not be retrieved or calculated.
- During computation, the message "Calculating..." will be displayed and after computation has finished, the data will be retrieved.
- In case you are retrieving data from instruments other than the OR1400, computation cannot be performed.
- In case of a data overflow, an error will occur. In such a case, change the method of computation.
- These computed data can be displayed and recorded as waveforms, displayed and recorded as digital data, and can be used for statistical computation; however, these data cannot be saved to the floppy disk.
- Arithmetic computation cannot be performed between blocks.
- Results of arithmetic computation cannot be output by communication interface.
- Only when calculation is set to "On", information concerning computation settings will be printed.

#### Operating Procedure

##### Calculation ON/OFF

Calculation ON/OFF should be selected at the memory format screen.

- 1 Press the MENU-key.
- 2 Select "#3 Memory format" using the soft keys.
- 3 Move the cursor to the "Calculation" setting.
- 4 Select "On" or "Off" using the soft keys.

Memory format		Off
Sample rate	: 50kHz	.....
Memory length	: 1k	.....
No. of blocks	: 8 (20.0ms)	On
Playback conditions		.....
Auto mode	: Accumulate	.....
Calculation	: <input checked="" type="checkbox"/>	.....
Format	: Strip chart	.....
Expansion	: 100 (Data/cm)	.....
	( 5.0m/s )	.....
Trigger print	: On	.....
Block printout	: Current only	.....
Data retrieve	: Total	.....

### Arithmetic Computation

- 1 Press the MENU-key.
- 2 Press the NEXT soft key and select "#7 Retrieve calculation".
- 3 Select the number of the channel which will retrieve the computed data.
- 4 Select "On" using the soft keys.
- 5 Enter the computation formula by soft keys.
- 6 Enter the upper and lower scale by soft keys and rotary knob. Enter the range within the following range:  $-1.0 \times 10^{+10} \leq x < -1.0 \times 10^{-10}$ ,  $0$ ,  $1.0 \times 10^{-10} < x \leq 1.0 \times 10^{+10}$ .  $-1.0 \times 10^{+10}$  will be set as  $-1.0e+10$ .
- 7 Enter the required unit by cursor keys and rotary knob (max. 6 characters).
- 8 The setting has been completed.

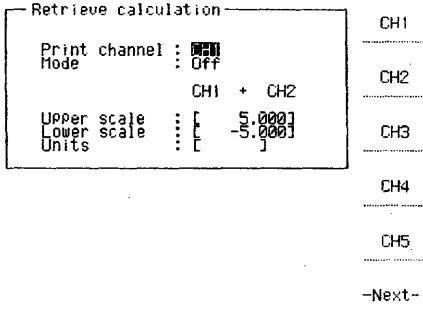

### Comparing Data on Time Series

Perform steps 1 to 4 as described under Arithmetic Computation.

- 5 Enter the channel and the block number which data will be retrieved according to the following format "Channel number : Block number". (: is the computation symbol).
- 6 Enter the upper and lower scale by soft keys and rotary knob. Enter the range within the following range:  $-1.0 \times 10^{+10} \leq x < -1.0 \times 10^{-10}$ ,  $0$ ,  $1.0 \times 10^{-10} < x \leq 1.0 \times 10^{+10}$ .  $-1.0 \times 10^{+10}$  will be set as  $-1.0e+10$ .
- 7 Enter the required unit by cursor keys and rotary knob (max. 6 characters)
- 8 Set the channel number and block number of a different channel, which you want to display on the same time axis, in the same way as before.
- 9 By displaying or recording the computational channels, differences in data on the same time axis will be clearly visible.

## 7.7.2 Performing Statistical Computation

This section describes how to perform computations as maximum, minimum, average and effective value, regarding a designated interval.

After retrieving data from memory, the following statistical computations can be done concerning the designated interval of the memory:

- Maximum value (MAX), and the time\* at which the maximum value occurred.
- Minimum value (MIN), and the time\* at which the minimum value occurred.

\* written as the time span elapsed from the trigger point.

- Average (AVG)

$$AVG = \frac{\sum_{i=m}^n D(i)}{n - m + 1}$$

- Effective value (RMS)

$$RMS = \sqrt{\frac{\sum_{i=m}^n D^2(i)}{n - m + 1}}$$

The display on which to perform statistical computations looks as follows:

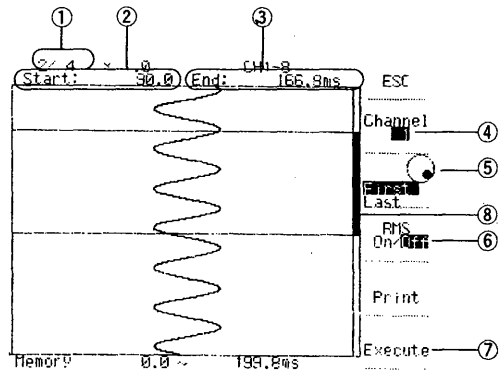

- ① If you divided the memory into blocks, this will indicate which block is being displayed
- ② Starting time of statistical computation (measured from the point triggering starts)
- ③ Finishing time of statistical computation (measured from the point triggering starts)
- ④ Setting of the channel for computation
- ⑤ Selection of starting/finishing point of data
- ⑥ Setting the RMS computation ON or OFF
- ⑦ Executing the computation
- ⑧ Computation interval (settable by rotary knob)

- When setting the computation interval by rotary knob, you can set the interval more accurately by using the FINE-key.
- The computed results can be printed out, and its contents is as follows:  
 Sample rate  
 Trigger date and time  
 Channel number  
 Linear scaling ON/OFF  
 Linear scaling coefficient  
 Linear scaling offset value  
 Unit of measurement data  
 Unit of time during which data was taken  
 Results of computation

**NOTE**

Pressing the "ESC" soft key during computation will result in abortion of the process. The message "Execution aborted" will appear.

You can move the display which shows the results up or down the screen using the cursor keys. When the results are shown in the upper side of the screen, you may execute computation again which will result in displaying the new results (in the lower side of the screen) together with the previous results. By switching the computation channel, you may display the computation results of two different channels at the same time. The printout will not show both results, just the latest results.

**NOTES**

- When setting linear scaling, computation will be performed using the scaled values.
- When data overrange occurs during the designated interval, computation will not be carried out.
- After completion of the computations, turning the rotary knob will result in disappearance of the computation data of the screen.

**Operating Procedure**

- 1 Press the SHIFT-key and the MEMORY PRINT-key. The Captured Data Playback screen will show the data as analog waveforms.
- 2 Select "Statis calc" using the soft keys.
- 3 Select the number of the computation channel using the "Channel" soft key.
- 4 Designate the interval of computation using the rotary knob. The starting / ending point can be changed using the corresponding soft key.
- 5 Select whether RMS computation will be done (ON) or not (OFF).
- 6 The computation will be performed when pressing the "Execute" soft key. The progress of computation will be shown on the display until the computation has finished. When computation has finished, a window with the results will appear.
- 7 Pressing the "Print" soft key will result in a printout of the computation data.

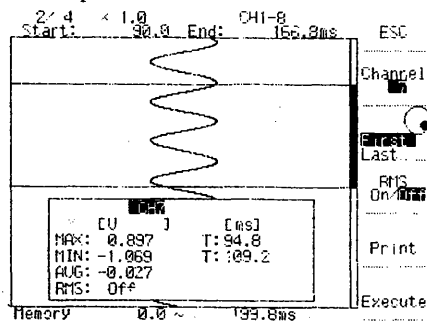

7 Printing and Displaying Captured Data

### 7.7.3 Statistical Computation by Auto Mode Function

This section describes how to use the Auto mode function for automatically performing statistical computation and displaying the results, or for automatically performing statistical computation and printing the results, or for automatically performing statistical computation and saving the results to a floppy disk.

When using the Auto mode function for statistical computation, you can select from the following three modes:

#### Auto statis

Data will be taken from the memory, and after performing statistical computations, the results will be displayed. When the trigger has been set to "repeat", the computational results of only the current block will be displayed.

#### Auto statis & Print

Data will be taken from the memory, and after performing statistical computations, the results will be both displayed and printed. The format of the printout will be as standard.

#### Auto statis & File

Data will be taken from the memory, and after performing statistical computations, the results will be both displayed and saved to the floppy disk in ASCII format. The filename will be "STATIS.LOG". When the trigger has been set to "repeat" and data will be captured to memory continuously, these data will be added to the "STATIS.LOG" file. In case of using the MEMORY START/STOP-key, or a communication interface, or an external trigger for capturing data to memory, the file will be overwritten (which results in loss of previous data).

### Operating Procedure

- 1 Press the MENU-key.
- 2 Select "#3 Memory format" using the soft keys.
- 3 Move the cursor to the "Auto mode" setting.
- 4 Select "Statis", "Statis & Print" or "Statis & File" using the soft keys.
- 5 Select the number of the channel to be computed; computation on all channels is also possible.
- 6 Select whether RMS should be computed or not.

Memory format		CH1
Sample rate	: 50kHz	.....
Memory length	: 1k ( 20.0ms)	.....
No. of blocks	: 8	CH2
Playback conditions		CH3
Auto mode	: Statis.	.....
Auto statis CH	: Off	.....
Auto statis RMS	: Off	.....
Calculation	: On	CH4
Format	: Strip chart	.....
Expansion	: 100 [Data/cm]	.....
	( 5.0m/s )	.....
Trigger Print	: On	CH5
Block printout	: Current only	.....
Data retrieve	: Total	.....
		-Next-

#### NOTES

- Computation cannot be operated while recording is in progress.
- Computation cannot be operated when the recording format is set to X-Y.

```
Jan.30.93 15:00:00
CH1
V ms
S:0      E:999
MAX:0.0139 692
MIN:-0.0139 700
AVG:0.0002 999
RMS:0.0098 999
#END
```

} one data

```
Jan.30.93 14:30:00 ← Time of triggering
CH1                ← Channel of computation
V ms              ← Unit of measurement data, unit of time
S:0      E:999    ← S:Time between the triggering
                  point and the start of computation
                  E:Time between the triggering
                  point and the end of computation
MAX:0.0255 645
MIN:-0.0255 650
AVG:0.0003 999
RMS:0.0198 999
#END
```

} Each computation result and the time elapsed since the triggering point (In case of AVG and RMS, the time shows the time from starting the computation to the end of computation)



# Floppy Disks

This chapter describes how to use Floppy Disks to save and load setups and measurement data.

## 8.1 Using Floppy Disks Properly

### Floppy Disks To Be Used

The following 3.5-inch floppy disks can be used:

- 2DD type: 720KB (MS-DOS format, or to be formatted by OR1400)
- 2HD type: 1.2MB (MS-DOS format, or to be formatted by OR1400)
- 1.44MB (MS-DOS format, or to be formatted by OR1400)

### How to Insert the Floppy Disk

Hold the floppy disk as shown in the figure below and insert it into the slot until the eject button pops out.

### How to Eject the Floppy Disk

Press the eject button after having verified that the accessing indicator is not lit.

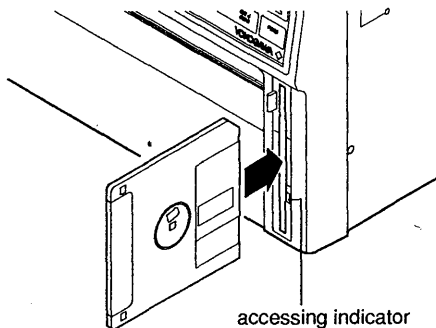

#### CAUTION

When ejecting the floppy disk from the slot while the indicator is lit, the magnetic head of the disk drive might be damaged, and data on the disk might be lost.

### Handling Precautions Regarding the Floppy Disk

For handling precautions regarding the floppy disk refer to the instruction manual accompanying the floppy.

### When Using a Personal Computer

Special software is necessary when reading data which is saved in binary format.

For more information on this topic, contact your nearest representative. Addresses may be found on the back cover of this manual.

## 8.2 Formatting a Floppy Disk

### Caution on Formatting

Note that formatting a floppy disk erases all data on the disk. Insert the floppy disk into the slot to verify whether the disk has been previously formatted. If it has already been formatted, the volume label and available free memory space will appear on the Load/Save Settings screen.

### Kinds of Format

You can select any of the following three formats:

- 720KB (2DD) : A 2DD floppy disk will be formatted into 9 sections.
- 1.2MB (2HD) : A 2HD floppy disk will be formatted into 8 sections.
- 1.44MB (2HD) : A 2HD floppy disk will be formatted into 18 sections.

### Volume Label

You can enter a volume label of up to 11 characters for the newly formatted floppy disk. These characters can be letters, digits or other valid MS-DOS characters (such as !, #, \$, %, ', (), {}, -, ^, \_ and ~), except that the first character cannot be a space. Lowercase characters will be regarded as uppercase characters.

### Operating Procedure

- 1 Insert the floppy disk into the slot.
- 2 Press the MENU-key.
- 3 Select "#5 Load/Save" using the soft keys.
- 4 Select "FD" using the soft keys.
- 5 Set "Utility" using the soft keys.
- 6 Select the required format using the soft keys.
- 7 Insert the volume label using the rotary knob. For information on entering the characters, refer to 3.2.
- 8 Select "Execute" using the soft keys.
- 9 Press the "Yes" soft key. The message "Formatting..." will appear while formatting is in progress.

### NOTE

When selecting "#5 Load/Save" while there is no floppy in the slot, the message "Media not ready" will appear on the screen.

## 8.3 Saving Setups

This section describes how to save setups to a floppy disk, entered either manually or through a communication interface.

### What You Should Know

Before using a floppy disk for the first time, it has to be formatted. See 8.2.

#### Number of Files You Can Save

The number of files you can save to a floppy disk containing either setups or measurement data, are as follows:

2DD(720KB)	2HD(1.2MB)	2HD(1.4MB)
112	192	224
(111)	(191)	(223)

(when a volume label has been set)

Always insert the floppy disk before you select "#5 Load/Save" from the menu. Consequently, the volume label and available space information will appear. Otherwise, you have no means of checking that you are using the correct floppy or that there is enough memory on the floppy.

#### Data Which Cannot Be Saved

You cannot save setups related to communication interfaces, RJC check settings, floppy disk's SAVE/LOAD operations, the color of the background setting, the language of the display, and the current date and time.

#### File Name

You give each setup an MS-DOS compatible file name of one to eight characters. These characters can be letters, digits or other valid MS-DOS characters (such as !, #, \$, %, &, ', (, ), {, }, -, ^, \_ and ~). When you do not append a file name, the message "Invalid file name" will appear.

#### NOTE

The message "Media not ready" appears on the screen when you select "#5 Load/Save" while no floppy is inserted in the slot.

## Operating Procedure

- 1 Insert the floppy disk into the slot.
- 2 Press the MENU-key and select "#5 Load/Save" using the soft keys.
- 3 Select "FD" using the soft keys at the "Media" setting. The cursor moves to the "Mode" setting.
- 4 Select "Panel" using the soft keys. The cursor moves to the "Function" setting.
- 5 Select "Save" using the soft keys. The cursor moves to the "File name" setting.
- 6 Enter the required characters here using the rotary knob (see 3.2 to enter characters).
- 7 Move the cursor onto the "Execute" command.
- 8 Press the "Yes" soft key when you want to start saving. The message "Saving..." will appear on the screen. When saving finishes, the screen will return to the previously active screen. When a file having an identical name already exists, the "Same file name exists. OK?" message will be displayed. When the existing file is to be overwritten, press the "Yes" soft key. If a different file name is to be designated, press the "No" soft key and enter the new file name.

```

Load/Save
Media < > : FD 1221KB
Mode      : Panel
Function  : Save
Filename  : [ ] Execute
    
```

BS

DEL

INS

```

! " # $ % & ' ( ) * + , - . / : ; < > ? @ [ \ ] ^ _ ` { | } ~
4 5 6 7 8 9 0 . * + , - . / : ; < > ? @ [ \ ] ^ _ ` { | } ~
i j k l m n o p q r s t u v w x y z
    
```

CAPS

ALP

EU

77

## 8.4 Saving Measurement Data

This section describes how to save measurement data to a floppy disk.

### What You Should Know

Before using a floppy disk for the first time, it has to be formatted. See 8.2.

The data can be saved in either binary or ASCII format. However, data saved in ASCII format cannot be loaded. Use a personal computer for this purpose.

### Number of Files You Can Save

See 8.3.

### Save Operation and Memory Blocks

If you have partitioned the available memory into blocks, the save operation stores data to the floppy disk one block at a time starting from the current memory block. The current block is the last block recorded, displayed or printed. To change the current block, see the operating procedure on changing the block to be saved on page 8-4.

### Channel and Data Contents

You can limit the number of channels and the range of data to be saved. See the operating procedure for specifying the range to be saved on page 8-4. For the data range, setting is available on the Memory Data Playback screen. See 7.5.

### File Name

You give each measurement data file an MS-DOS compatible file name of one to eight characters. These characters can be letters, digits or other valid MS-DOS characters (such as !, #, \$, %, &, ', (, ), {, }, ~, ^, \_ and ~). When you do not append a file name, the message "Invalid file name" will appear.

### Required Memory

For binary data:

The memory required to save the data is given by the following formula:

Required memory = File header length + Data length (bytes)

where

- file header length =  $152 + (64 \times A) + (32 \times B)$  rounded up to the next integer multiple of 64;  
A = number of analog channels\* + (8 x number of logic channels\*)  
B = number of analog channels\* + number of logic channels\*
- data length =  $2 \times \text{memory length}^{**} \times \text{number of selected channels}^*$

\* The number of channels to be saved, except channels set to "off" or "save option".

\*\* Measurement data length to be saved.

### Example

In case you want to save the data of 8 analog channels and 2 logic channels at a length of 1K, the required memory can be calculated as follows:

$$\text{File header length} = 152 + (64 \times 24) + (32 \times 10) = 2008$$

The nearest integer multiple of 64 is therefore 2048

$$\text{Data length} = 2 \times 1000 \times 10 = 20000$$

Therefore, the required memory becomes 22048bytes.

For ASCII data:

The memory required to save 1000 measurement data is as follows:

for 8 analog channels: approx. 90kbytes

for 8 analog channels + 2 logic channels: approx. 250kbytes.

### NOTE

The message "Media not ready" appears on the screen when you select "#5 Load/Save" while no floppy disk is inserted in the slot.

## Operating Procedure

### Saving Measurement Data

- Insert the floppy disk into the slot.
- Press the MENU-key and select "#5 Load/Save" using the soft keys.
- Select "FD" using the soft keys at the "Media" setting. The cursor moves to the "Mode" setting.
- Select "Data" using the soft keys. The cursor moves to the "Function" setting.
- Select "Save Binary" or "Save Ascii" using the soft keys. The cursor moves to the "File name" setting.
- Enter the required characters here using the rotary knob (see 3.2 to enter characters).
- Move the cursor onto the "Execute" command (see the next pages for the "Save block" and "Option" settings).
- Press the "Yes" soft key when you want to start saving. The message "Saving..." will appear on the screen. When saving finishes, the screen will return to the previously active screen. When a file having an identical name already exists, the "Same file name exists. OK?" message will be displayed. When the existing file is to be overwritten, press the "Yes" soft key. If a different file name is to be designated, press the "No" soft key and enter the new file name.

Load/Save		No
Media	: FD	.....
<	>	1221KB
Mode	: Data	Yes
Function	: Save (Binary)	.....
Filename	: t	.....
Save block	: 1	.....
Option	: Off	.....

### Changing the Block and then Saving the Measurement Data

- 7 Before moving the cursor onto the "Execute" command, move it onto the "Save block" setting.
- 8 Press the soft key corresponding to the required block number.
- 9 The cursor moves to the "Execute" setting. Press the "Yes" soft key when you want to start saving. The message "Saving..." will appear on the screen. When saving finishes, the screen will return to the previously active screen. When a file having an identical name already exists, the "Same file name exists. OK?" message will be displayed. When the existing file is to be overwritten, press the "Yes" soft key. If a different file name is to be designated, press the "No" soft key and enter the new file name.

Load/Save			1	
Media	:	FD 1221KB		
Mode	:	Data	2	
Function	:	Save (Binary)		
Filename	:	[ Execute	3	
Save block	:	Off	4	
Option	:		5	
				-Next-

### Specifying the Range to be Saved

- 7 Before moving the cursor onto the "Execute" command, move it onto the "Option" setting.
- 8 Select "Set option" using the soft keys if you want to change the current -optional- settings regarding saving. (If you do not want to change the current - optional - settings, select "on" using the soft keys and the cursor moves to the "Execute" setting. Refer to step 8 on the previous page.)

Load/Save			Off
Media	:	FD 1221KB	
Mode	:	Data	On
Function	:	Save (Binary)	
Filename	:	[ Execute	
Save block	:	Off	
Option	:		

- 9 The Save Options Settings Screen will appear.
- 10 Move the cursor onto the channel which you want to save, and select "Yes" using the soft keys.
- 11 Repeat this for all the channels which you want to save.
- 12 In case of saving in Ascii format, move the cursor to the "Data skip" setting. If no data is to be skipped, set "1" (see also 7.2). The "Data skip" setting has only significance when saving in the Ascii format.
- 13 Move the cursor onto the range start and range end settings and adjust the starting and/or ending point by turning the rotary knob.
- 14 Select "Setting" using the soft keys and the settings will be kept. You will return to the Load/Save setting screen. The "Option" setting is turned "On" and the cursor will be at the "Execute" setting. When you select "ESC" using the soft keys, all operations from step 9 will be ignored and you will return to the Load/Save setting screen.
- 15 Select "Yes" using the soft keys. A "Saving..." message will appear on the screen. When saving finishes, the cursor will move to the "File name" setting.

In case you do not want to start saving at the time, select "No" using the soft keys.

Data save option			ESC
Select save channels			
1	:	No	No
2	:	No	
3	:	No	
4	:	No	Yes
5	:	No	
6	:	No	
Logic			
A :	No	B :	No
Data skip :	1		Setting
Set limit to save data			
First :	0		
Last :	999		

## 8.5 Saving Captured Data

This section describes how to save captured data to the floppy disk while being displayed on the screen.

### What You Should Know

#### File Name

The data will be saved under the file name MEM□□□.xxx. The data format can be either binary or ascii. □□□ will be a number automatically applied starting from 000. xxx is the extension, which will be applied automatically; DAT in case of binary format, ASC in case of ASCII format.

#### Cautions when Saving Captured Data

- Beware that files will be overwritten if files with the same names already exist.
- The option setting at the 'Load/Save' screen remains valid when saving captured data to the floppy disk. However, the data range can be adjusted by the rotary knob on the display.
- When there is not sufficient space available at the floppy disk, the error message 'Not enough space to save' will appear and the saving will be interrupted.
- When the number of files exceeds the maximum number, the error message 'Directory full' will appear and saving will be interrupted.

### Operating Procedure

- 1 Press the SHIFT-and the MEMORY PRINT-key. The captured data will appear on the screen as analog waveforms.
- 2 Press the 'Next'-soft key and select "FD save".
- 3 Select the range of data to be saved by specifying the starting and ending point. Select "First" and "Last" using the soft keys.
- 4 Select the format in which you want to save from "binary" or "ascii" using the soft key.
- 5 Press the "Save execute" soft key to start saving. The message 'saving ...' will appear.

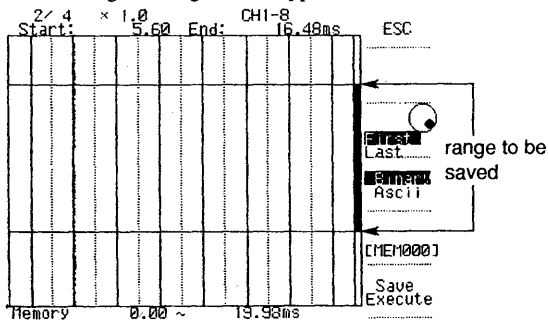

## 8.6 Loading Setups or Measurement Data

This section describes how to load a file containing control settings or measurement data from the floppy disk.

### What You Should Know

#### Contents of the Load Screen

A list of file names will appear on the screen with the dates and times that trigger conditions were satisfied. When the data is saved on other equipments, the date and time the file was saved, is displayed. A "Invalid file format" message indicates that either the file contains invalid data, is of a type not supported by the OR1400 or is otherwise unloadable.

#### Notes for Loading Setups

The setup or measurement data which you load from a floppy disk will replace the current setup and data in the OR1400. Note that data capture always overwrites data loaded from a floppy disk, even when memory partitioning is in effect, as the save operation stores memory blocks as individual files.

Always insert the floppy disk before you select "#5 Load/Save" from the menu. Consequently, the volume label and available space information will appear. Otherwise, you have no means of checking that you are using the correct card.

Files saved in the ascii format cannot be loaded.

### Operating Procedure

- 1 Insert the floppy disk into the slot.
- 2 Press the MENU-key and select "#5 Load/Save" using the soft keys.
- 3 Select "FD" using the soft keys at the "Media" setting. The cursor moves to the "Mode" setting.
- 4 Select "Panel" (to load setups) or "Data" (to load measurement data) using the soft keys. The cursor moves to the "Function" setting.
- 5 Select "Load" using the soft keys. The cursor moves to the "File name" setting.
- 6 Press the soft key corresponding to the number of the required file name displayed in the lower half of the screen. The cursor moves onto the "Execute" command.
- 7 Press the "Yes" soft key when you want to start saving. The message "Loading..." will appear on the screen. When loading finishes, the screen will return to the previously active screen.

In case you don't want to start loading here, press the "No" soft key. The screen will return to the "File name" setting.

Load/Save		# 1
Media	: FD 932KB	
Mode	: Data	# 2
Function	: Load	
Filename	: [ ]	# 3
	: Execute	
#1	AT001 95/02/01 22:43	# 4
#2	TEST01 95/02/01 22:51	
#3		# 5
#4		
#5		-Next-

## 8.7 Deleting Setups or Measurement Data

This section describes how to delete a file containing setups or measurement data from a floppy disk.

### What You Should Know

Always insert the floppy disk before you select “#5 Load/Save” from the menu. Consequently, the volume label and available space information will appear. Otherwise, you have no means of checking that you are using the correct card.

### Operating Procedure

- 1 Insert the floppy disk into the slot.
- 2 Press the MENU-key and select “#5 Load/Save” using the soft keys.
- 3 Select “FD” using the soft keys at the “Media” setting. The cursor moves to the “Mode” setting.
- 4 Select “Panel” (to delete setups) or “Data” (to delete measurement data) using the soft keys. The cursor moves to the “Function” setting.
- 5 Select “Delete” using the soft keys. The cursor moves to the “File name” setting.
- 6 Press the soft key corresponding to the number of the required file name displayed in the lower half of the screen. The cursor moves onto the “Execute” command.
- 7 Press the “Yes” soft key when you want to start deleting. The message “Deleting...” will appear on the screen. When deleting finishes, the screen will return to the previously active screen.

In case you don't want to start deleting here, press the “No” soft key. The screen will return to the “File name” setting.

Load/Save		# 1
Media	: FD 932KB	
Mode	: Data	# 2
Function	: Delete	
Filename	: [AT001]	# 3
	Execute	
#1	AT001 95/02/01 22:43	# 4
#2	TEST01 95/02/01 22:51	
#3		# 5
#4		
#5		-Next-

### NOTE

The message “Media not ready” appears on the screen when you select “#5 Load/Save” while no floppy disk is inserted in the slot.

## 8.8 Displaying Information on Measurement Data Files

This section describes how to display information about a floppy disk file containing measurement data.

### What You Should Know

#### Type of Information

You can display the following information about measurement data files:

- Trigger time Date and time that trigger conditions were satisfied.
- Data Number of saved samples.
- Sample rate Sample rate in Hz. For measurement data saved using other sources, the unit is seconds.
- Sampled by Name of the source used to save the measurement data. However, spaces will be displayed in case of the OR1400, while “Other” will be displayed for other instruments.
- Save ch No. This is the number of channels saved. The “Number of ch” is also displayed for files saved using other sources.

Always inserts the floppy disk before you select “#5 Load/Save” from the menu. Consequently, the volume label and available space information will appear. Otherwise, you have no means of checking that you are using the correct card.

### Operating Procedure

- 1 Insert the floppy disk into the slot.
- 2 Press the MENU-key and select “#5 Load/Save” using the soft keys.
- 3 Select “FD” using the soft keys at the “Media” setting. The cursor moves to the “Mode” setting.
- 4 Select “Data” using the soft keys. The cursor moves to the “Function” setting.
- 5 Select “Info.” using the soft keys. The cursor moves to the “File name” setting.
- 6 Press the soft key corresponding to the number of the required file name displayed in the lower half of the screen. The information will appear.
- 7 Select “ESC” using the soft keys to return to the previous menu.

Load/Save		ESC
Media	: FD 932KB	
Mode	: Data	
Function	: Information	
Filename	: [AT001]	
Trigger time	: 95/02/01 22:39	
Data	: 1000	
Sample rate	: 50kHz	
Save ch No.	: 1, 2, 3, 4 5, 6, 7, 8 A, B	

## 8.9 Saving Captured Data to the Floppy Disk by Auto Mode Function

This section describes how to save captured data to the floppy disk automatically using the Auto mode function.

### What You Should Know

The Auto mode function allows you to save your measurement data automatically to the floppy disk after data capture finishes. After saving to the floppy disk, the previously active mode will return.

Instead of saving to the floppy disk, it is also possible to have your measurement data printed automatically when data capture finishes. See 7.3 for details.

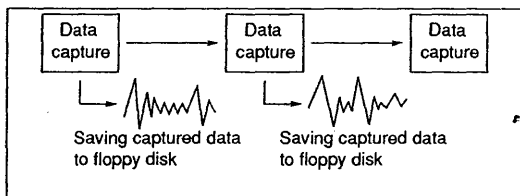

The data capture settings are selected in the normal way on the "#3 Memory condition" screen and the "#4 Trigger" screen. However, note the following differences:

- If you have divided the memory into blocks, the recorder saves to the floppy disk the data from each block immediately after it is full.
- If you have selected one of the repeat trigger modes, the recorder starts capturing data each time the trigger conditions are met and then saves the data to the floppy disk when data capture finishes.

Data will be saved under the file names "AUTO000", "AUTO001", etc.. Note that when the auto mode function has been stopped and started again, the same file names will be used and therefore old files will be overwritten.

### Operating Procedure

- 1 Press the MENU-key.
- 2 Select "#3 Memory format" using the soft keys.
- 3 Move the cursor to the "Auto mode" setting and select "FD" using the soft keys.
- 4 Press the MEMORY START/STOP-key to start.

Memory format		Off
Sample rate	: 50kHz	
Memory length	: 1k	
	( 20.0ms )	
No. of blocks	: 8	Print
Playback conditions		
Auto mode	: <input checked="" type="checkbox"/>	FD
Calculation	: On	
Format	: Strip chart	Display
Expansion	: 100 [Data/cm]	
	( 5.0ms )	
Trigger print	: On	Accum.
Block printout	: Current only	
Data retrieve	: Total	
		-Next-

### NOTES

- When the available space at the floppy disk runs out, the message "Not enough space to save" will appear. The saving process will be interrupted. Delete abundant files or use another card.
- When the number of files exceed the number which can be stored, the message "Directory full" will appear. The saving process will be interrupted. Delete abundant files or use another card.
- Be aware that when files with the same names exist, these will be overwritten by this auto mode function without message.
- The captured data cannot be saved to the floppy disk by Auto Mode Function while real time recording is in progress.
- The option setting at the 'Load/Save' screen remains valid when saving captured data to the floppy disk. However, the data range can be adjusted by the rotary knob on the display.

# Miscellaneous Functions

This chapter describes the way to use other functions, which have not been explained so far. They include linear scaling, initializing and printing control settings, start and stop the chart using external controls and others.

## 9.1 Linear Scaling

This section describes how to use the linear scaling function to change the scale of the X- and Y-axis for measurements of physical quantities, such as mechanical distortion, vibration, pressure, displacement and acceleration.

### What You Should Know

Two random scale values (SP1, SP2) which correspond to two measurement voltage/temperature values (VP1, VP2) are designated. The scale conversion method ( $y=ax+b$ ) is determined according to these four settings. Based on this linear scaling method, the full-scale values which have been designated at the Input Setting screen (enter by pressing a CH-key) will be converted as shown in the Example.

#### Example

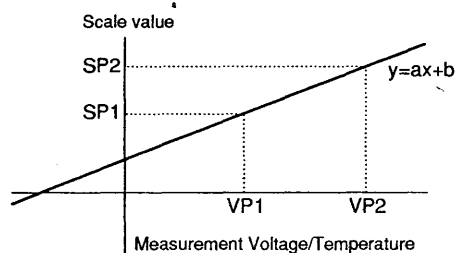

When full-scale values are -5V to 5V, and VP1=3V, VP2=5V, SP1=50kg and SP2=100kg :

$$y = \frac{50 - 100}{3 - 5} x + \frac{3 \times 100 - 50 \times 5}{3 - 5}$$

Scale conversion formula :  $y = 25x - 25$

Minimum full-scale value =  $25 \times (-5) - 25 = -150\text{kg}$

Maximum full-scale value =  $25 \times (5) - 25 = 100\text{kg}$

Full-scale values after conversion : -150kg to 100kg

#### NOTE

The linear scaling formula is obtained by the following calculation:

$$y = \frac{SP1 - SP2}{VP1 - VP2} x + \frac{VP1 \times SP2 - SP1 \times VP2}{VP1 - VP2}$$

### Permissible Setting Range

The permissible setting range for the measurement voltage/temperature (VP1, VP2), and the scale values (SP1, SP2) is as follows:

$$1.0E - 10 < \text{Setting value} \leq 1.0E + 10$$

$$\text{Setting value} = 0$$

$$-1.0E + 10 \leq \text{Setting value} < -1.0E - 10$$

If a setting outside the above range is attempted, the error message "E200: Out-of-range setting" will appear.

### Settings Designated for Each Channel

Linear scaling settings are designated for each channel. Besides, linear scaling can be selected "On" and "Off" at each channel.

### Unit

A 6-character unit is the maximum.

### Measure Function

The measurement voltage/temperature (VP1, VP2) values can be designated as the measurement values for the selected channel's current input signal.

### Setting Error

If the measurement voltage/temperature (VP1, VP2) and scale value (SP1, SP2) settings are designated as being equal (VP1=VP2 and/or SP1=SP2), a setting error will occur and the message "E203: Cannot set this data" will be displayed.

#### NOTE

When designating large values as VP1, VP2 and SP1, SP2, the settings can be designated using a mantissa and an exponent as follows:  $-1.0E + 10$ .



## Operating Procedure

- 1 Press the CH-key for which you want to set linear scaling.
- 2 Move the cursor onto the "Utility" command.
- 3 Press the "Span scaling" soft key.
- 4 Move the cursor onto the "Scaling" command.
- 5 Select "On" or "Off" using the soft keys. The cursor moves to the "Units" setting.
- 6 Enter the required unit here using the rotary knob (see 3.2 to enter characters).

CH1 Range 10U		ESC
Lower	: [ -5.000 ] U	Off
Upper	: [ 5.000 ] U	On
Scaling	: [ On ]	
Units	: [ ]	
	Volts Scale	
Pos.1	: [ 0.000 ] [ 0.000 ]	
Pos.2	: [ 2.000 ] [ 2.000 ]	

### Entering a Value for VP1 and SP1

- 6 Move the cursor to the "Volts", "µe" or "Frequency" setting of the "Pos.1" setting and set the value VP1. You can do this by pressing the "Measure" soft key to have this value measured automatically, or you can enter this value yourself using the rotary knob. The 'lower' value corresponds with the lower value of the span setting.
- 7 Press the "Enter" soft key. The cursor moves to the "Pos.1" setting of the "Scale" setting.
- 8 Enter the SP1 value using the rotary knob.
- 9 Press the "Enter" soft key.

### Entering a Value for VP2 and SP2

- 10 Move the cursor to the "Volts", "µe" or "Frequency" setting of the "Pos.2" setting and set the value VP2. You can do this by pressing the "Measure" soft key to have this value measured automatically, or you can enter this value yourself using the rotary knob. The 'upper' value corresponds with the upper value of the span setting.
- 11 Press the "Enter" soft key. The cursor moves to the "Pos.2" setting of the "Scale" setting.
- 12 Enter the SP2 value using the rotary knob.
- 13 Press the "Enter" soft key.

### NOTE

- The engineering unit of the Pos.1 and Pos.2 values is "V". Even if the span values are designated in mV, the Pos.1 and Pos.2 values become V.
- You can copy the linear scaling settings to any other channel the same way as other channel settings. See 3.3.7.

## Assigning Scale Values for Pos.1 and Pos.2

- 7 Set the "Volts", "µe" or "Frequency" setting of Pos.1 to "Lower" using the soft key.
- 8 Press the "Enter" soft key. The cursor will move to the "Scale" setting of Pos.1.
- 9 Use the rotary knob and the cursor keys to set the value.
- 10 Press the "Enter" soft key.
- 11 Set the "Volts", "µe" or "Frequency" setting of Pos.2 to "Upper" using the soft key.
- 12 Press the "Enter" soft key. The cursor will move to the "Scale" setting of Pos.2.
- 13 Use the rotary knob and the cursor keys to set the value.
- 14 Press the "Enter" soft key.

CH1 Range 10U		ESC
Lower	: [ -5.000 ] U	DEL
Upper	: [ 5.000 ] U	Lower
Scaling	: [ On ]	Measure
Units	: [ ]	Enter
	Volts Scale	
Pos.1	: [ 0.000 ] [ 0.000 ]	
Pos.2	: [ 2.000 ] [ 2.000 ]	

### Setting the Scale Values

- 1 Press the CH-key for which you want to set the scale.
- 2 Move the cursor to "Utility".
- 3 Select "Span scaling" using the soft keys.
- 4 Enter the scale value at the "Lower" setting using the rotary knob and cursor keys.
- 5 Press the "Enter"-key.
- 6 The cursor moves to the "Upper" setting.
- 7 Enter the scale value at the "Upper" setting using the rotary knob and cursor keys.
- 8 Press the "Enter" soft key.

CH1 Range 10U		ESC
Lower	: [ 0.000 ] U	DEL
Upper	: [ 5.000 ] U	Pos.1,2 data
Scaling	: [ Off ]	
Units	: [ ]	
	Volts Scale	
Pos.1	: [ 0.000 ] [ 0.000 ]	
Pos.2	: [ 2.000 ] [ 2.000 ]	

### Assigning Pos.1 and Pos.2 as the Scale Values

- Perform step 1 to 3 as described above.
- 4 Move the cursor to either the "Lower" or "Upper" setting.
  - 5 Press the "Pos.1, 2 data" soft key.

### 9.1.1 Linear Scaling for Strain Measurement Data

In case of 1/2 bridge or full bridge measurements, the measurement results after slightly from the actual phenomenon. (basically, the measurement results  $\geq$  the actual phenomenon). In case you are using the strain gage converter as a load cell or acceleration converter, the engineering unit of the measurement value and the actual phenomenon differs. For example, in case of the load cell, the engineering unit of actual phenomenon is kgf, whereas the engineering unit of the measurement value is  $\mu\epsilon$ .

Using the scaling function, it is possible to adjust the measurement values to the actual values of the phenomenon.

The settings are explained hereafter with the use of an example.

Specification for a strain input unit connected with an acceleration converter :

- rated output
- recommended applied voltage : 3V
- rated capacity :  $\pm 10G$

#### Operating Procedure

1. Press the CH-key to which the acceleration converter is connected.
2. Set the measurement range to 2000 $\mu\epsilon$ , since the rated output of the acceleration converter is 1073 $\mu\epsilon$ .
3. Move the cursor to the 'BV' setting.
4. Using the soft keys, set the bridge excitation voltage to a value smaller than or equal to the recommended applied voltage, therefore being 2 V or 3 V.
5. Move the cursor to the 'Utility' setting.
6. Select 'Span scaling' using the soft keys.
7. Enter the scale value '-1073' at the 'Lower' setting using the rotary knob and soft keys.
8. Press the 'Enter' soft key.
9. Move the cursor to the 'Upper' setting and set the scale value '1073' using the rotary knob and soft keys.
10. Press the 'Enter' soft key.
11. Move the cursor to the 'Scaling' setting.
12. Press the ON soft key. The cursor moves to the 'Unit' setting.
13. Set the engineering unit of the actual phenomenon (G) using the rotary knob.  
In this example, the actual value of 0G corresponds to a measurement value of 0 $\mu\epsilon$ ; where as the actual value of 10G corresponds to a measurement value of 1073 $\mu\epsilon$ . Therefore, the Pos1 and Pos2 settings will be set accordingly.
14. Move the cursor to the  $\mu\epsilon$  setting for Pos.1.
15. Enter the value '0' using the rotary knob.
16. Press the Enter soft key. The cursor moves to the 'Scale' setting for Pos.1.
17. Enter the value '0' using the rotary knob.
18. Press the Enter soft key. The cursor moves to the ' $\mu\epsilon$ ' setting for Pos.2.
19. Enter the value '1073' using the rotary knob.
20. Press the Enter soft key. The cursor moves to the 'Scale' setting for Pos.2.
21. Enter the value '10' using the rotary knob.
22. Press the Enter soft key.

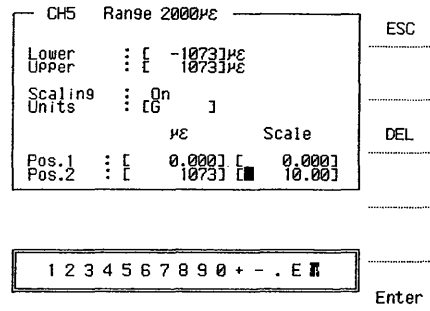

By following the above example, you have adjusted the recording span of the measurement result to the rated capacity of the phenomenon (span). Furthermore, when you set the recording zone to '1 Zone 200 mm', 1 will correspond with 1G. (Refer to 4.4 Fixed and Flexible Zone Recording).

#### NOTE

- In case of scaling of strain measurement data, the extension  $10^{-6}$  will automatically be applied to the Pos.1 and Pos.2 values. For example, setting the value  $2.0e^{-1}$  will result in 20000  $\mu\epsilon$ .

## 9.2 Resetting Control Settings and Memory

This section describes how to reset control settings to their initial settings (factory defaults) and how to clear the acquisition memory, which is the memory used for data storage.

### What You Should Know

There are different levels of resetting:

- Reset all settings and initialize all the acquisition memory.
- Initialize all the acquisition memory.

The only control settings that will not be reset are the date, time, communication settings, color of the background, setting data in the internal RAM and backed up data.

You cannot clear memory of blocks independently when you clear the acquisition memory.

The initial settings are shown in Appendix B.

### Operating Procedure

#### Reset all settings and initialize all the acquisition memory.

- 1 Press the MENU-key.
- 2 Press the NEXT soft key and select "#9 System".
- 3 Select "#4 Initialize" using the soft keys. The message "Setting initialized" and the message "Acq. memory initialized" will appear on the screen, while the alarm beep can be heard.

#### Initialize all the acquisition memory

- 1 Press the SHIFT-key and the MEMORY PRINT-key. The captured data will appear on the screen.
- 2 Press the "Next" soft key and select "Block".
- 3 Select "Reset" using the soft keys. The message "OK to delete acq. data?" will appear.
- 4 Select "Yes" using the soft keys and the acquisition memory will be initialized.

## 9.3 Changing System Settings

This section describes how to turn the alarm beep on or off, how to select whether to keep back-up data, how to select the memory print mode, and the color of the background.

### What You Should Know

#### Alarm Beep

The alarm beep can be selected on or off. The initial value is "On".

#### Back-Up Data

You can select to continue with your recording/data capturing after a power failure. When recording/data capturing is in progress and the power turns off and on again, the recorder will continue as before the power turned off. Note that measurement data will not be kept after the power turned off. The initial value is "Off".

#### Background

You can select the background to be either white or blue. Note that this setting will not be saved to the internal RAM or to the floppy disk when saving setups.

### Operating Procedure

#### Alarm Beep

- 1 Press the MENU-key.
- 2 Press the NEXT soft key and select "#9 System".
- 3 Select "#5 Misc" using the soft keys.
- 4 Move the cursor to the "Alarm beep" setting.
- 5 Select "On" or "Off" using the soft keys.

Misc		
Alarm beep	On	Off
External ST/SP	Record	
Rec/Mem back up	Off	
Chart clock up	Internal	On
Ext. key board	ASCII	
Hard copy mode	TIFF	

#### Back-up Data

- 1 Press the MENU-key.
- 2 Press the NEXT soft key and select "#9 System".
- 3 Select "#5 Misc" using the soft keys.
- 4 Move the cursor to the "Rec/Mem back up" setting.
- 5 Select "On" or "Off" using the soft keys.

#### Background

- 1 Press the MENU-key.
- 2 Press the NEXT soft key and select "#9 System".
- 3 Select "#1 System" using the soft keys.
- 4 Move the cursor to the "Back ground" setting.
- 5 Select "White" or "Blue" using the soft keys.

## 9.4 Printing a Setup List

This section describes how to print a list of the current control settings onto the chart.

### What You Should Know

The following control settings will not be printed:

- Volume label, file names and other settings from the "#5 Load / Save" screen.
- Settings from the RJC check settings screen.

Once started, this printout cannot be interrupted.

This printout is not available:

- during real-time recording;
- during data capture;
- while printing out captured data;
- when waiting for a trigger;
- during feeding the chart;
- while printing a hard copy of the screen.

Full-scales values are output as non-converted values, even if Linear scaling is on.

For an example of this printout, see appendix B.

### Operating Procedure

Press the SHIFT-key and MENU-key to start this printout.

## 9.5 Getting a Hardcopy of the Display

This section describes how to get a hardcopy of the display.

### What You Should Know

Getting a hardcopy can be done in three different ways.

- Just a hardcopy on paper (print)
- A hardcopy on paper and saving this data to the floppy in BMP format (BMP)
- A hardcopy on paper and saving this data to the floppy in TIFF format (TIFF).

Once started, these printouts cannot be interrupted.

This printout is not available:

- during real-time recording;
- during data capture;
- while printing out captured data;
- during feeding the chart.

### Operating Procedure

Selecting the type of hardcopy

1. Press the MENU-key.
2. Press the NEXT soft key and select "#system".
3. Select "#5MISC" using the soft keys.
4. Move the cursor to the 'Hardcopy mode' setting.
5. Select the required setting using the soft keys.

Misc		Print
Alarm beep	: On	.....
External ST/SP	: Record	.....
Rec/tem back up	: Off	.....
Chart clock	: Internal	BMP
Ext. key board	: ASCII	.....
Hard copy mode	: <b>TIFF</b>	TIFF
		.....
		.....
		.....
		.....

### Printing the Hardcopy

Press the SHIFT-key and CHART SPEED-key to start this printout.

### NOTES

- The message "Media not ready" appears on the screen when you selected 'BMP' or 'TIFF' while no floppy is inserted in the slot and you tried to print the hardcopy.
- Before using a floppy disc for the first time, it has to be formatted. See 8.2 Formatting a Floppy Disk.

## 9.6 Using an External Control to Start/Stop

This section describes how to use an external input signal to start / stop real-time recording, start / stop data capturing, to print event messages, and to start a manual printout.

### What You Should Know

#### Input Signals

The recorder supports two types of input control signals.

- TTL level (High/Low) High: 2.7 V or more; Low: 0.8 V or less.
- Contact (Open/Close) When closed, approximately 5mA current flows.

The input transitions are as shown below.

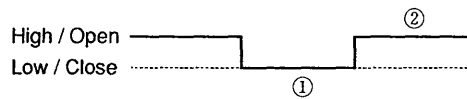

Status	①	②
recording	recording starts	recording stops
data capture	data capture starts	data capture stops*
event message	prints the next message	-
manual printout	manual printout starts	-

\* Nothing will happen in case data capture is already finished.

In the case of event message printing, you cannot specify which event message will be printed. The messages will be printed in numerical order. Therefore, at the first change, message 1 will be printed, at the next change, message 2, etc.. This is regardless the event messages are all spaces or not.

#### Input Connector

The external input terminal (EXT INPUT/OUTPUT) is located at the rear panel. The connector looks as follows.

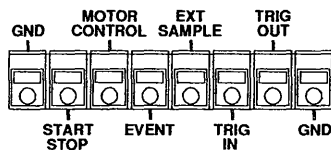

For connecting, refer to 2.5.4.

#### Input Circuit Configuration

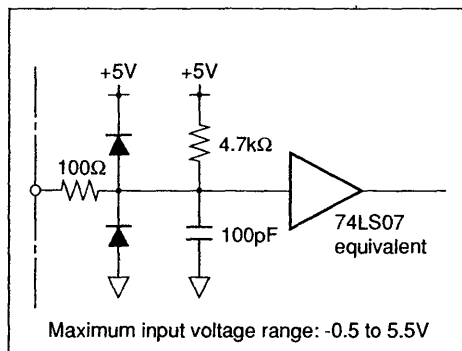

#### CAUTION

Applying a voltage outside the maximum input voltage range can damage the input circuit.

#### NOTES

- Do not use signal cables in excess of 3 m. long as they can pick up noise that can disrupt the recorder operation.
- Signals that start real-time recording are ignored under certain circumstances. Refer to section 4.2.
- When you set an external input signal, the panel keys RECORD START/STOP and MEMORY START/STOP can be used too. So you can stop recording/data capturing, which has been started by an external signal, using the panel keys. In case you started recording/data capturing using the panel keys already and after that the external signal to start occurs, nothing will happen.

### Operating Procedure

- 1 Connect a signal cable to START/STOP terminal at the EXT INPUT/OUTPUT terminal, located on the rear panel.
- 2 Press the MENU-key.
- 3 Select "#9 System" using the soft keys.
- 4 Select "#5 Misc" using the soft keys.
- 5 Move the cursor onto the "External ST/SP" setting.
- 6 Select the required setting using the soft keys. You can select from

Record : Real-time recording start and stop

Memory : Data capturing start and stop

Rec&Mem : Both real-time recording and data capturing start and stop

Message : Event message printing.

Data print : Measurement data at the time of contact change will be printed.

Misc	Record
Alarm beep	On
External ST/SP	Record
Rec/Mem back up	Off
Chart clock	Internal
Ext. key board	ASCII
Hard copy mode	TIFF

Record  
Memory  
Rec&Mem  
Message  
Data Print

## 9.7 Changing the Chart Speed Using an External Control

### What You Should Know

#### Input Signal

The following two TTL-level input signals are possible.

- frequency up to 1280Hz
  - pulse width of 2  $\mu$ s or more.
- The chart speed changes by the frequency of the input signal. The relation is as follows.
- $$f = 32 V$$
- where  $f$  : frequency of the input signal (Hz)  
 $V$  : chart speed (mm/s)

e.g. When you want a real-time recording chart speed of 10 mm/s, input a TTL-level signal of 320 Hz.

#### Input Connector

The external input terminal (EXT INPUT/OUTPUT) is located at the rear panel. The connector looks as follows.

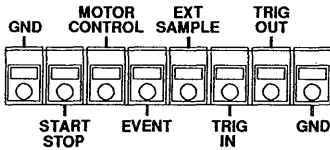
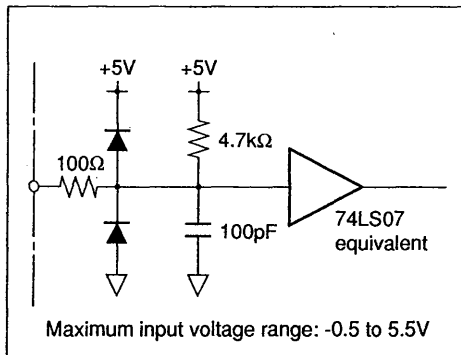

Chart speed control is regulated by the MOTOR CONTROL terminal.

For connecting, refer to 2.5.4.

#### Input Circuit Configuration



#### CAUTION

Applying a voltage outside the maximum input voltage range can damage the input circuit.

#### NOTE

Do not use signal cables exceeding 3 m in length as they can pick up noise that can disrupt recorder operation.

### Operating Procedure

- 1 Press the MENU-key.
- 2 Select "#9 System" using the soft keys.
- 3 Select "#5 Misc" using the soft keys.
- 4 Move the cursor to the "Chart clock" setting.
- 5 Select "Ext." using the soft keys.
- 6 Connect the external input cable to the "MOTOR CONTROL" terminal at the rear panel.
- 7 Apply the external signal and start real-time recording.
- 8 Control the chart speed by regulating the frequency of the external input signal.

Misc		
Alarm beep	On	Int.
External ST/SP	Record	
Rec/Mem back up	Off	
Chart clock	Ext.	Ext.
Ext. key board	ASCII	
Hard copy mode	TIFF	

## 9.8 Entering an Event Marker Using an External Control

### What You Should Know

#### Input Signal

The following two types of input signals are available.

- TTL-level (High/Low)  
High : 2.7 V or more  
Low : 0.8 V or less
- Contact (Open/Close)

In case of close, approx. 5 mA current follows.

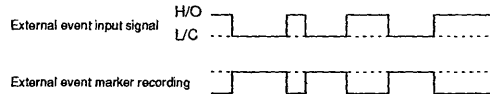

#### Recording Position

Refer to 4.17.

#### Input Connector

The external input terminal (EXT INPUT/OUTPUT) is located at the rear panel. The connector looks as follows.

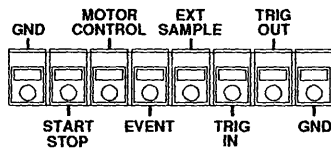

Event marker printing is regulated by the EVENT terminal.

For connecting, refer to 2.5.4.

#### Input Circuit Configuration

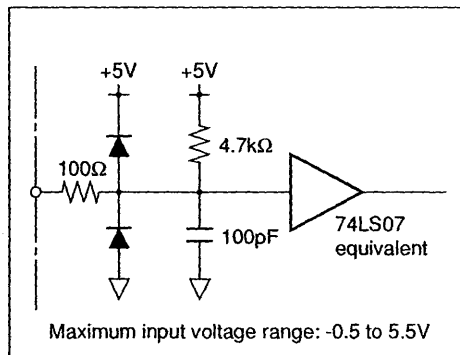

#### CAUTION

Applying a voltage outside the maximum input voltage range can damage the input circuit.

#### NOTE

Do not use signal cables exceeding 3 m in length as they can pick up noise that can disrupt recorder operation.

### Operating Procedure

- 1 Press the MENU-key.
- 2 Select "#2 Print format" using the soft keys.
- 3 Set "Analog" at the "Mode" setting.
- 4 Make sure "X-Y" is not selected at the "Format" setting.
- 5 Move the cursor to the "Tick/Event" setting.
- 6 Select "Event" using the soft keys.
- 7 Select the external input cable to the "EVENT" terminal at the rear panel.
- 8 Apply the external signal when an event marker is required.

Print format		Off
Mode	: Analog	
Format	: 1 Zone[200mm]	
Grid intensity	: Dark	
Grid type	: 10mm fine	
Scale print	: On	
Annotation	: Off	0.01
Channel print	: On [400mm]	
Header print	: Time	0.1
Flexible zone	: Boundary	
Shot recording	: Off	
Tick / Event	: Event	1
		-Next-

## 9.9 Data Capture Using an External Sampling Clock

This section describes how to use an external clock signal as the sampling clock for data capture.

### What You Should Know

#### Input Signals

100kHz maximum frequency input is available with TTL-level signals.

#### Input Connector

The external input terminal (EXT INPUT/OUTPUT) is located at the rear panel. The connector looks as follows.

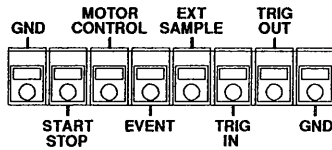

Data capture using an external sampling clock is regulated by the EXT SAMPLE terminal. For connecting, refer to 2.5.4.

#### Input Circuit Configuration

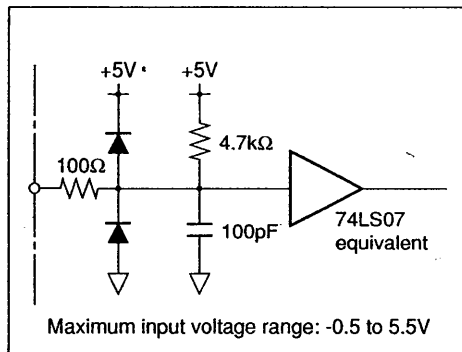

#### CAUTION

Applying a voltage outside the maximum input voltage range can damage the input circuit.

#### NOTES

- When real-time recording is in progress, the maximum sample rate is 50kHz.
- Do not use signal cables in excess of 3 m. long as they can pick up noise that can disrupt the recorder operation.
- Since the A/D converter uses the same external clock signal, the choice of clock frequency can affect the display and recording resolutions of the sampled data.
- The time scale on displays and printouts of T-Y analog waveforms recorded using an external sampling clock use the number of data samples instead of time units.

### Operating Procedure

- 1 Press the MENU-key.
- 2 Select "#3 Memory condition" using the soft keys.
- 3 Select "Ext." using the soft keys. Note that it might be necessary to press the "-Next-" soft key.

Memory format		1Hz
Sample rate	: 1000Hz	
Memory length	: 1k	
No. of blocks	: 8 (Ext.)	0.5Hz
Playback conditions		0.2Hz
Auto mode	: FD	
Calculation	: On	
Format	: Strip chart	0.1Hz
Expansion	: 100 [Data/cm] (External)	
Trigger Print	: On	Ext.
Block printout	: Current only	
Data retrieve	: Total	
		-Next-



## 9.10 Operating Multiple Recorders in Parallel

This section describes how to use the recorder's output to synchronize multiple recorders operating in parallel.

### What You Should Know

#### Recorder Configurations

There are two configurations which you can use to connect multiple recorders:

Type A : where one recorder generates the external trigger signal for the others;

Type B : where an external source supplies the trigger signal.

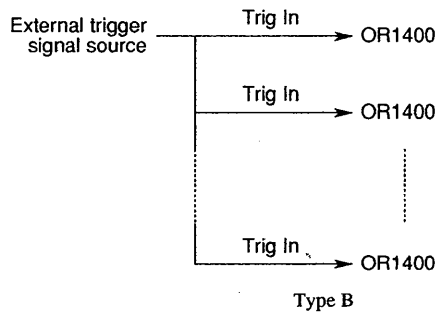
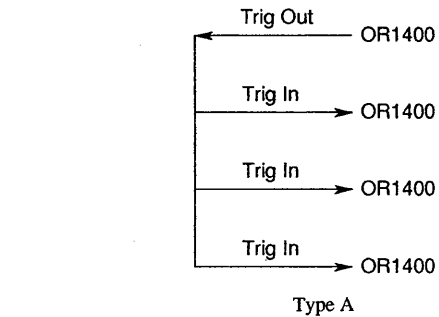

#### Number of Recorders

Type A : Supports up to four recorders, including the one supplying the trigger;

Type B : Can support as many recorders as the output impedance of the external trigger source will allow.

#### Signals

Trig out : TTL-level, leading edge ( $\uparrow$ ) signal with a minimum pulsewidth of  $2\mu\text{s}$ .

Trig in : TTL-level, leading edge ( $\uparrow$ ) or trailing edge ( $\downarrow$ ) signal with a minimum pulsewidth of  $2\mu\text{s}$ .

### Input and Output Circuit Configurations

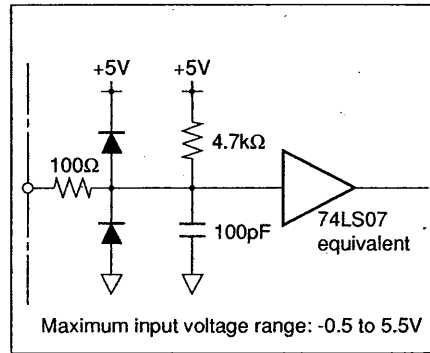

Input circuit configuration (TRIG IN)

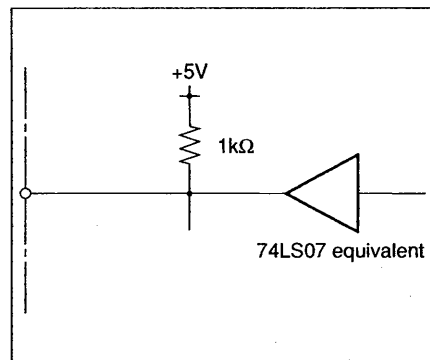

Output circuit configuration (TRIG OUT)

#### Failure to Synchronize

Note that the recorder ignores external trigger signals during both real-time recording and data capturing. To ensure proper synchronization for type A configurations, always set triggering to the single-trigger mode for both the recorder generating the trigger signal and the recorders receiving the trigger signal.

## Operating Procedure

Follow the steps 1 to 11 for type A configuration and start from step 5 for type B configuration.

### Recorders generating the trigger signal (Type A only)

- 1 Press the MENU-key.
- 2 Select "#4 Trigger" using the soft keys.
- 3 Move the cursor to the "Mode" setting.
- 4 Select "Single" using the soft keys.

### Recorders receiving the trigger signal (Type A and B)

- 5 Press the MENU-key.
- 6 Select "#4 Trigger" using the soft keys.
- 7 Select "External" using the soft keys.
- 8 Move the cursor to the "Mode" setting.
- 9 Select "Single" using the soft keys.
- 10 Connect a signal cable to the TRIG IN or TRIG OUT terminal, located on the rear panel, according to your setup.

Parallel operation is available after the above steps have been completed.

#### CAUTION

Applying a voltage outside the maximum input voltage range can damage the input circuit. When operating multiple recorders in parallel, consuming electric power gets higher. Therefore, a suitable power source should be used. For the maximum electric power per one unit see page 12-11.

#### NOTES

- Do not use signal cables in excess of 3 m. long as they can pick up noise that can disrupt the recorder operation.
- For type A configurations, there is a delay between the internal trigger signal and the Trig Out signal. When the trigger action is set to "Record", the length of this delay is determined by the recorder's trigger action (10 $\mu$ s during real-time recording and one sampling period during data capture).

## 9.11 Checking Sampling Conditions

This section describes how to review the sampling conditions you used to capture the data stored in memory, including the input and memory settings, even if you have changed the settings since.

### What You Should Know

There are two screens where you can check sampling conditions.

#### Scale of Stored Data

You can check the full-scale values and the units for each channel on the following screen:

Scale of stored data			ESC
CH	Upper	Lower	Range
1:	5.000	-5.000	
2:	5.000	-5.000 U	
3:	5.000	-5.000 U	
4:	5.000	-5.000 U	
5:	5.000	-5.000 U	
6:	5.000	-5.000 U	
7:	50.00	-50.00 U	
8:	0.5000	-0.5000 U	

- ① Maximum full-scale value
- ② Minimum full-scale value

#### Memory Information

You can check the memory length, sample rate and the measurement ranges for each channel on the following screen:

Memory information		ESC
Memory size :	1k	
Sample rate :	External	
Range		
CH1 :	10U	
CH2 :	20U	
CH3 :	1U	
CH4 :	200mU	
CH5 :	100U	
CH6 :	20U	
CH7 :	50U	
CH8 :	50mU	
Logic CH-A :	On	
Logic CH-B :	On	

### Operating Procedure

- 1 Press the SHIFT-key and the MEMORY PRINT-key to display the Captured Data Playback screen.
- 2 Select "Scale" using the soft keys. The display showing the scales of stored data will appear.
- 3 Select "Range" using the soft keys. The display showing memory information will appear.
- 4 Use the "ESC" soft key to return to the Captured Data Playback screen.

#### NOTE

The sampling conditions cannot be checked for X-Y recording.

## 9.12 Saving /Loading a Backup of the Recorder's Setup

This section describes how to make a backup of a setup. This is useful when different setups are being used frequently, since it eliminates the need to enter settings again.

### What You Should Know

You can save up to four setups, where each can be given a unique name. The contents of the data which are saved concern the channel settings (such as input type and ranges) only.

A saved backup will be kept after the power has been turned off. Furthermore, a saved backup will not be reset by initializing as described in 9.2.

### Operating Procedure

#### Saving

- 1 Press the MENU-key.
- 2 Select "#5 Load/Save" using the soft keys.
- 3 Select "Int. RAM" using the soft keys at the "Media" setting.
- 4 Move the cursor to the "Function" setting and select "Save" using the soft keys. The cursor will move to the "File #" setting while the screen will show all previous saved setups together with their names.
- 5 Select the number of setup using the soft keys. Note that you can save up to four setups.
- 6 If required, enter your comment to the setup you are going to save.
- 7 Move the cursor to the "Execute" setting and select "Yes" using the soft keys. The message "Completed" will appear.

Load/Save				
Media	:	Int.RAM1		Set 1
Function	:	Save		Set 2
File #	:			Set 3
		Execute		
Comment	:	[テスト 1 ]		
Set1		95/02/01 23:52 [テスト 1 ]		
Set2		95/02/01 23:53 [Test 2 ]		Set 4
Set3		[ ]		
Set4		[ ]		

#### Loading

- 1 Press the MENU-key.
- 2 Select "#5 Load/Save" using the soft keys.
- 3 Select "Int. RAM" using the soft keys at the "Media" setting.
- 4 Move the cursor to the "Function" setting and select "Load" using the soft keys. The cursor will move to the "File #" setting while the screen will show all previous saved setups together with their names.
- 5 Select the number of setup you want to load using the soft keys. The cursor moves to the "Execute" setting.
- 6 Select "Yes" using the soft keys. The message "Completed" will appear.

# Trouble-Shooting

This chapter describes what to do if a problem arises with your recorder. This chapter also lists an explanation of the recorder's messages.

## 10.1 Diagnosing the Problem

This section describes how to diagnose any problem which might occur with your recorder. If a message appears on the screen, you should first check the explanation given in section 10.2. In case the recorder requires servicing, contact your sales representative.

Problem	Things to Do	Reference Page
The recorder does not power-up at turning on.	<ul style="list-style-type: none"> <li>• Check that the power switch is on.</li> <li>• Check that the power cord is firmly plugged in to the electrical outlet.</li> <li>• Check the power supply voltage against the recorder's rating.</li> </ul>	3-1
		2-4
		2-4
The settings are not backed up between sessions.	<ul style="list-style-type: none"> <li>• Change the backup battery if the "Battery flat" message appears. Note that its life is approx. 10 years.</li> <li>• Contact your sales representative.</li> </ul>	
The panel keys do not function.	<ul style="list-style-type: none"> <li>• Check the REMOTE display LED. If the LED is ON, press the LOCAL-key.</li> <li>• If possible, test the keys as described in 11.1.</li> </ul>	9-6 11-1
The rotary knob does not function.	<ul style="list-style-type: none"> <li>• Check the REMOTE display LED. If the LED is ON, press the LOCAL-key.</li> <li>• If possible, test the keys as described in 11.1.</li> </ul>	9-6 11-1
Measurement values are obviously erroneous.	<ul style="list-style-type: none"> <li>• Noise might be picked up. Check that the recorder is grounded. Check that the measurement input ground is connected to the recorder's ground terminal.</li> <li>• Check the input filter settings.</li> <li>• Always allow the recorder to stabilize for at least 30 minutes before taking measurements to obtain full accuracy.</li> </ul>	3-3
Temperature measurement values are obviously erroneous.	<ul style="list-style-type: none"> <li>• Check that the two thermocouple leads are not too far apart.</li> <li>• Check that the thermocouple is not in contact with any metal surface.</li> <li>• Check the input filter settings.</li> </ul>	3-3
The printout is faint.	<ul style="list-style-type: none"> <li>• Check that you are using the proper type of thermal paper.</li> <li>• Clean the printer head as described in 11.4.</li> <li>• The printer head life is approx. 30km (approx. 750 stacks of paper). If this life is exceeded the printing quality may deteriorate, and the printer head must be replaced. For replacement, contact your sales representative.</li> <li>• Check that the recorder environment satisfies the conditions described in 2.2 or that there is no foreign matter trapped between the printer head and the paper. If so, contact your sales representative.</li> </ul>	3 11-2
		2-2
No print.	<ul style="list-style-type: none"> <li>• Check that the thermal paper is the right way up.</li> <li>• Check that the input type settings are not "Off" for all channels.</li> </ul>	2-12
		3-3

Problem	Things to Do	Reference Page
The trace intensity has become faint.	<ul style="list-style-type: none"> <li>• Check that the trace intensity has not been changed from dark to light.</li> <li>• Note that if the image is mostly blank, the recorder may have lowered the intensity as a safety measure to avoid overheating and thus damaging the print head.</li> <li>• Check the position of the LCD contrast controller.</li> </ul>	<p style="text-align: center;">4-9</p> <p style="text-align: right;">1-10</p>
The recorder cannot save data to a floppy disk.	<ul style="list-style-type: none"> <li>• Check that the floppy disk has been formatted for use with your recorder.</li> <li>• Check that the floppy disk is fully inserted in the slot.</li> <li>• Check that there is enough space available on the disk for the data.</li> </ul>	<p style="text-align: right;">8-1</p> <p style="text-align: right;">8-1</p> <p style="text-align: right;">8-6</p>
The recorder cannot load data from a floppy disk.	<ul style="list-style-type: none"> <li>• Check that the floppy disk is fully inserted in the slot.</li> <li>• Check that the floppy disk has been formatted for use with your recorder, either by the recorder itself or a compatible device.</li> <li>• Check that the data file format is compatible with your recorder.</li> </ul>	<p style="text-align: right;">8-1</p> <p style="text-align: right;">8-1</p> <p style="text-align: right;">8-1</p>
The GP-IB interface does not function.	<ul style="list-style-type: none"> <li>• Check that the control program knows the recorder's device address. If not, you will need to change the current address setting.</li> <li>• Unless the "yes" soft key is pressed after the cursor is moved to "Set", the setting cannot be changed.</li> </ul>	<p style="text-align: right;">IM 781011-11E</p>
The RS-232-C interface does not function.	<ul style="list-style-type: none"> <li>• Check that the control program knows the recorder's device address. If not, you will need to change the current address setting.</li> <li>• Unless the "yes" soft key is pressed after the cursor is moved to "Set", the setting cannot be changed.</li> <li>• Check that you are using the correct type of cable for the intended application.</li> </ul>	<p style="text-align: right;">IM 781011-11E</p>
The chart has jammed.	<ul style="list-style-type: none"> <li>• Turn the power off.</li> <li>• Remove the jammed paper by opening the cover, lifting the release lever and removing the paper.</li> </ul>	<p style="text-align: right;">3-1</p> <p style="text-align: right;">2-12</p>
The chart does not appear.	<ul style="list-style-type: none"> <li>• Check that the recorder has not run out of paper.</li> <li>• Check that the release lever is down, bringing the feed mechanism in contact with the paper.</li> <li>• Check that the paper protrudes properly from the paper compartment.</li> </ul>	<p style="text-align: right;">2-12</p> <p style="text-align: right;">2-12</p> <p style="text-align: right;">2-12</p>

## 10.2 Messages

This section describes the error messages and warning messages together with their description and handling.

When the messages are still displayed even though proper action has been taken, contact your sales representative.

### Error Messages

Message Code	Message	Description and Handling	Reference Page
0012	(Communication)	No such command. Cannot recognize the sent command. >Check whether the correct command and delimiter have been sent.	IM 781011-11E
0013	No such ch.	A channel has been selected for which no input unit is connected. >Connect the proper input unit, or change the channel setting.	
E120	No effective triggers	Tries to trigger in single or repeat mode when there is no effective trigger source. >Check that all trigger conditions, the source channel input type, the logic trigger or all channel trigger is not off.	3-3 6-7
E131	Memory storage unavailable	Cannot perform data capture during real-time recording when the trigger action is set to 'Record' or 'Chart speed'. >Perform data capture after stopping real-time recording.	4-3
E140	Out-of-range data	Tried to measure an out-of-range linear scaling setting value. >Set an appropriate measurement range setting.	9-1
E170	Cannot retrieve memory	Data cannot be retrieved due to computation settings and the corresponding settings. >adjust the memory length and / or number of blocks settings.	5-2, 5-3
E200	Out-of-range setting	Tried to set a value that is out of range or tried to enter text beyond the limit. >Set values that are within the legal range. >Input the correct value.	
E201	Syntax / lexical error	Incorrect date or time setting was attempted or invalid characters. >Enter the correct setting.	3-11
E203	Cannot set this data	Pos.1 and Pos.2 were designated the same value at the linear scaling setting. Tried to set the same upper and lower scale values for computations. >Designate different values.	9-1 7-13
E204	Less than allowable value	This value is less than the minimum allowable value.	
E210	Invalid parameter	Tried to set a parameter other than those allowed in the current setting using the communications interface. >Correct the parameter setting.	IM 781011-11E
E304	All channels are off	The input type setting is off for all channels.	3-3
E312	100kHz sample unavailable	While real-time recording is in progress with 100kHz, data capture cannot be done. >Change the sample rate	5-2

Message Code	Message	Description and Handling	Reference Page
E322	Illegal data present	Illegal data concerning statistical computation exist.	
E350	Change scale unavailable	Designated channel is incorrect.	
E500	Out of chart paper	>Load new chart paper.	2-12
E501	Printhead raised	Printer head is raised. >Press the printer release lever.	2-12
E502	Printhead disable	Printer fault detected when recording begins. >Contact your sales representative.	
E520	Invalid data number	First/last data number during captured data playback is invalid. The first data number is greater than the last data number or the last number is out of range. >Set appropriate first/last numbers.	7-6
E700	Media not ready	The media has not been inserted. >Insert the floppy.	8-1
E701	Media unformatted	The media has not been formatted. >Format the floppy.	8-2
E702	Media write protected	Floppy disk is write protected. >Remove the protection or use another floppy.	
E703	Load/Save unavailable	Tried to load/save while recording is in progress.	
E710	Specified file unavailable	Cannot find the specified file. Tried to delete an unretrievable dump file.	8-5, 8-8
E715	Invalid file name	File name is too long or invalid symbols or characters have been used. >Use a valid file name.	8-2
E716	Invalid volume label	Volume label is too long or invalid symbols or characters have been used. >Use valid characters/symbols.	8-2
E720	No data to save	There is no data to save in the acquisition memory to save to the floppy disk. >Save after data capture.	5-1
E721	No data for specified ch.	No data in the load file. The specified file cannot be loaded.	
E723	Not enough space to save	There is not enough space on the media. >Delete unnecessary files or save onto another media.	
E724	Directory full	Number of files that can be stored in the root directory has been exceeded. >Delete unnecessary files or save onto another floppy disk.	8-2
E728	Invalid file format	OR1400 cannot process this file format.	8-1
E729	Format version mismatch	Cannot process because the format version is different.	
E732	Cannot read this data type	Tried to load a data type OR1400 cannot handle.	8-1
E733	Cannot find specified data	An attempt was made to load the measurement data of channels 5 to 8 to a 4-channel model.	

Message Code	Message	Description and Handling	Reference Page
E734	Write protected	The files are write protected. Cannot overwrite or delete the data.	
E740	Cannot save this data type	Cannot save the contents of files loaded from another recorder.	8-1
E745	Load/save error	Data cannot be loaded/saved, because the media is extracted from the slot, or physical failure occurred. >Insert a proper media card.	
E760	Invalid during output	Tried to format the floppy disk, or to load/save/delete data, or to check settings, or to sample by panel key, while data output was in progress. >Perform those operation after data output has finished.	
E765	Dump already completed	Tried to dump same data again while dump has already been completed.	8-8
E900	RAM error	Detected an RAM error. >Contact your sales representative.	
E901	Acq. memory error	Detected an error in the acquisition memory. >Contact your sales representative.	
E950	Comm. card error	Detected an error in the communications card. >Contact your sales representative.	
E951	FDD Card error	Control card of the floppy disk is not working properly. >Contact your sales representative.	
E960	Printer card error	Detected an error in the printer card. >Contact your sales representative.	

#### Warning Messages

Message Code	Message	Description and Handling	Reference Page
W000	No captured data	No measurement data.	
W003	No data on X-axis	The X-axis channel number has not been selected, or the input type is off.	3-3 4-10
W200	End of chart paper	Ran out of chart paper during recording. >Load chart paper.	2-12
W202	Printhead inactive	Abnormal voltage has been detected at printer head. >To continue the recording operation, switch the power off and on again. >If the abnormal voltage is detected again, contact sales representative.	
W203	Printhead overloaded	Printer head load is too heavy and the printer head temperature has reached its limit (occurs under continuous, heavy printing). >Select the light trace intensity to preserve the printer head. When the temperature of the head falls, you can continue recording as before.	
W500	Acq. memory initialized	Acquisition memory has been initialized.	9-4



Message Code	Message	Description and Handling	Reference Page
W510	Battery flat	The backup battery for the clock setting is flat. >Contact your sales representative.	
W520	Settings initialized	Setting values are changing. They have been initialized.	9-4
W521	Calendar clock reset	Calendar clock has been reset.	
W522	Equipment changed	Detected the change of input unit. When this change is made, all settings will be initialized. >When this happened without any change being made, contact your sales representative.	
W910	A/D NV-RAM 1 error	Detected an error in A/D converter RAM 1. >Contact your sales representative.	
W911	A/D NV-RAM 2 error	Detected an error in A/D converter RAM 2. >Contact your sales representative.	
W912	A/D NV-RAM 3 error	Detected an error in A/D converter RAM 3. >Contact your sales representative.	
W913	A/D NV-RAM 4 error	Detected an error in A/D converter RAM 4. >Contact your sales representative.	
W914	A/D NV-RAM 5 error	Detected an error in A/D converter RAM 5. >Contact your sales representative.	
W915	A/D NV-RAM 6 error	Detected an error in A/D converter RAM 6. >Contact your sales representative.	
W916	A/D NV-RAM 7 error	Detected an error in A/D converter RAM 7. >Contact your sales representative.	
W917	A/D NV-RAM 8 error	Detected an error in A/D converter RAM 8. >Contact your sales representative.	
W920	Comm. card unavailable	Communications card has not been installed properly or is missing. >Contact your sales representative to have the card installed properly.	
W921	Comm. card error	Detected an error in the communications card interface. >Contact your sales representative.	
W922	Comm. parameter error	A parameter setting error was detected at a communication control command. >Contact your sales representative.	

# Testing and Maintenance

This chapter describes some routine tests and maintenance which you can perform yourself in order to confirm that your recorder works properly.

## 11.1 Testing the Panel Keys and Rotary Knob

This section describes how to test the operation of the keys and rotary knob located on the front panel.

### What You Should Know

When testing the panel keys and rotary knob, a symbolic display of the front panel will appear on the screen.

Pressing a key should result in inverting the corresponding area. Turning the rotary knob clockwise should result in increasing the number on the screen, turning the knob counterclockwise should result in decreasing the number.

If a panel key or the rotary knob does not behave as expected, contact your sales representative. The screen looks as follows.

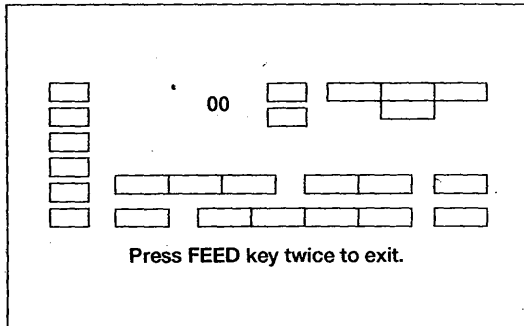

### Operating Procedure

- 1 Press the MENU-key.
- 2 Select "#9 System" using the soft keys.
- 3 Select "#3 Self test" using the soft keys.
- 4 Select "#2 Key test" using the soft keys.
- 5 Press the keys and turn the rotary knob to test their correct operation.
- 6 Press the FEED-key twice to return to the "Self test" screen. Note that pressing the FEED-key for the first time will check its operation.

## 11.2 Testing the Memory

This section describes how to test the memory when data capture obviously generates erroneous results.

### What You Should Know

A list of memory types is displayed on the screen with indications of whether each passed (OK) or failed (NG) the test.

If a memory type does not pass the test (NG), contact your sales representative.

The screen looks as follows.

Memory test	
ROM	: OK
RAM1	: OK
RAM2	: OK
VRAM(Disp)	: OK
VRAM(Wave)	: OK
VRAM(Print)	: OK
Aqu. 1 - 4	: OK
Aqu. 5 - 8	: OK
Aqu. Logic	: OK

### Operating Procedure

- 1 Press the MENU-key.
- 2 Select "#9 System" using the soft keys.
- 3 Select "#3 Self test" using the soft keys.
- 4 Select "#3 Memory test" using the soft keys. The test will start immediately after the key is pressed.
- 5 If all memories are OK, the test will be ended automatically. You will return to the "Self test" screen. If an NG memory has been detected, the FEED-key must be pressed to return to the "Self test" screen.

## 11.3 Checking the Thermocouple Accuracy

This section describes how to check the accuracy of your recorder for temperature measurements by thermocouple input.

### What You Should Know

The OR1400 uses a built-in reference junction compensation (RJC) circuit to compensate for thermocouple input signals. For this test you will need to change the RJC settings on the "RJC check" screen.

#### Settings

##### Internal

Compensation enabled

##### Zero fix

Compensation disabled

If a temperature measurement is obviously erroneous, contact your sales representative.

### Operating Procedure

#### Setting Up

- 1 Connect a DC-coupled reference voltage source to the channel to be tested.
- 2 Press the corresponding CH-key for that channel.
- 3 Set the required thermocouple type using the soft keys.

#### Testing

- 4 Press the MENU-key.
- 5 Select "#9 system" using the soft keys.
- 6 Select "#3 Self test" using the soft keys.
- 7 Select "#4 RJC check" using the soft keys.
- 8 Move the cursor to the channel to be tested.
- 9 Select "Zerofix" using the soft keys.
- 10 Select "Setting" using the soft keys. The message "Settings completed" will appear.
- 11 Press the MONITOR-key until the numeric display appears.
- 12 Input the voltage which is equivalent to the reference junction temperature for your thermocouple.
- 13 Check that the displayed temperature of the corresponding channel is correct.

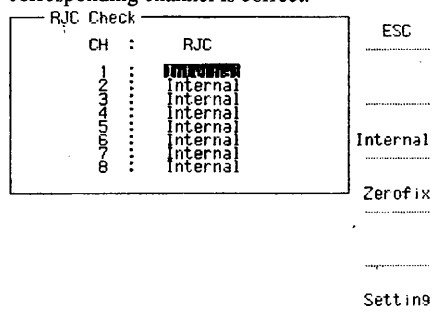

#### NOTES

- This test requires that both the OR1400's internal circuits and the DC-coupled input reference voltage be stable. Therefore allow the OR1400 at least 30 minutes to stabilize.
- When the power turns on again, settings have returned to "Internal" again.
- Even when not all 8 input units are connected, 8 channels appear on the display.

## 11.4 Cleaning the Printer Head

This section describes how to clean the printer head when your printouts become unclear and difficult to read.

### What You Should Know

When you clean the printer head, a pattern is recorded onto the chart paper as shown below. The cleaning of the head takes approximately ten seconds, and cannot be interrupted.

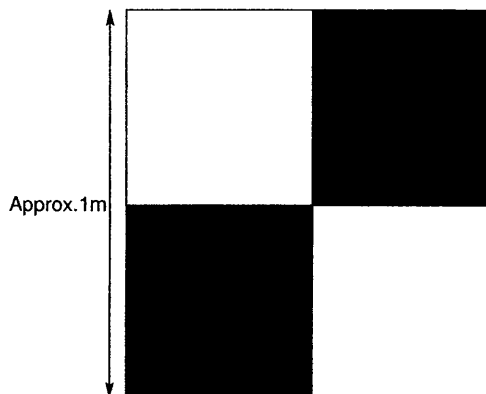

### Operating Procedure

- 1 Press the MENU-key.
- 2 Select "#9 system" using the soft keys.
- 3 Select "#3 Self test" using the soft keys.
- 4 Select "#1 Print head cleaning" using the soft keys. The test will start immediately after the key is pressed.

#### NOTES

- If your printouts are still no better after having cleaned the head, contact your sales representative.
- The life of the printer head is approximately 30 km (or about 750 chart stacks). When the printer head exceeds this amount, the printing quality might become poor and the head needs to be replaced. Contact your sales representative for servicing.

## 11.5 Replacing the Fuse

This section describes how to replace the fuse.

### What You Should Know

It is recommended to replace the fuse at least once every two years for preventive maintenance. Before replacing the fuse, always make sure to turn OFF the power.

### Operating Procedure

- 1 Pull out the fuse holder by placing a screw driver under the tab and pulling the holder forward.
- 2 Push fuse 1 downwards to remove it.
- 3 Push fuse 2 in either horizontal direction to remove it. Note that fuse 2 is a spare one.
- 4 Make sure the ratings of the new fuses are correct and install them.
- 5 Click the holder back into its place.

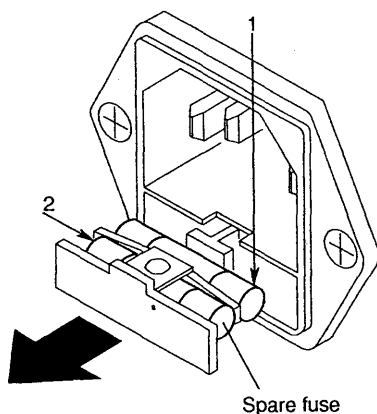

### WARNING

Before replacing the fuse, make sure to turn OFF the power supply and disconnect the power source. Use only specified fuses which should only be obtained from your sales representative. The usage of other fuses might cause fire. Fuse specifications : 250 V/4 A, Time lag

# Specifications

This chapter describes the specifications of the OR1400 recorder.

## 12.1 Measurement Inputs

### Voltage Inputs Units (783051)

Number of channels	1/unit
Input type	Floating, unbalanced, isolated channels
Measurement range & accuracy	As shown below (filter off, zero suppression off, at 23±°5C)

DCV input

Measurement Range	Actual Measurement Range	Accuracy
500 V	±350.0 V	±(0.5% of meas. range)
200 V	±200.0 V	±(0.5% of meas. range)
100 V	±100.0 V	±(0.5% of meas. range)
50 V	±50.00 V	±(0.5% of meas. range)
20 V	±20.00 V	±(0.5% of meas. range)
10 V	±10.00 V	±(0.5% of meas. range)
5 V	±5.000 V	±(0.5% of meas. range)
2 V	±2.000 V	±(0.5% of meas. range)
1 V	±1.000 V	±(0.5% of meas. range)
500 mV	±500.0 mV	±(0.5% of meas. range)
200 mV	±200.0 mV	±(0.5% of meas. range)
100 mV	±100.0 mV	±(0.5% of meas. range)

Input coupling	DC
Suppression voltage	Can be turned on or off 100 mV to 5 V ranges: ±10 V 10 V to 500 V ranges: ±500 V
Setting accuracy	±10 V suppression ±1% ±500 V suppression ±2%
Frequency bandwidth (filters off)	DC – 40kHz (+1dB, –3dB, Typical)
A/D resolution	12 bit
Maximum sampling rate	100kS/sec
Maximum input voltage	350 VDC + ACpeak
Input impedance	1MΩ ± 1%
Noise	350μVp-p (Typical, zero suppression off) for 100mV input, short circuit input
Maximum floating voltage	350 VDC + ACpeak (between input terminal and case, between all channels)
Common mode rejection ratio	More than 80dB (50/60Hz, signal source resistance less than 500Ω)
Temperature coefficients	
Zero point	Automatically calibrated before measurement, and 0.03% of measurement range/ °C thereafter
Gain	0.02% of measurement range/°C
Filter	Lowpass filter, filter ON/OFF
Cutoff frequency	10Hz, 100Hz, 1kHz
Filter characteristics	–12dB/octave
Input terminals	Safety terminals (Bananaclip type)

**Weight** approx. 160 gr.

**Accessories** Measurement leads (1/unit)

**Universal Inputs Units (783052)**

**Number of channels** 1/unit

**Input type** Floating, unbalanced, isolated channels

**Measurement range & accuracy** As shown below (filter off, at 23±°5C)

DCV input

Measurement Range	Actual Measurement Range	Accuracy
50 V	±50.00 V	±(0.25% of m.r.* + 50µV)
20 V	±20.00 V	±(0.25% of m.r.* + 50µV)
10 V	±10.00 V	±(0.25% of m.r.* + 50µV)
5 V	±5.000 V	±(0.25% of m.r.* + 50µV)
2 V	±2.000 V	±(0.25% of m.r.* + 50µV)
1 V	±1.000 V	±(0.25% of m.r.* + 50µV)
500 mV	±500.0 mV	±(0.25% of m.r.* + 50µV)
200 mV	±200.0 mV	±(0.25% of m.r.* + 50µV)
100 mV	±100.0 mV	±(0.3% of m.r.* + 50µV)
50 mV	±50.00 mV	±(0.5% of m.r.* + 50µV)

\* m.r.=measurement range

TC input

Measurement Range	Actual Measurement Range	Accuracy <sup>1</sup>
K	-200.0 to 1300.0°C	± (0.2% of rdg + 1.5°C) however, -200 to 0°C: ± (0.5% of rdg + 1.5°C)
J	-200.0 to 1100.0°C	
E	-200.0 to 800.0°C	
T	-200.0 to 400.0°C	
L	-200.0 to 900.0°C	
U	-200.0 to 400.0°C	
N	0.0 to 1300.0°C	± (0.2% of rdg + 2°C) -200 to 0°C: ±6°C 200 to 800°C: ±4°C
R	0.0 to 1700.0°C	
S	0.0 to 1700.0°C	
B	0.0 to 1800.0°C	± (0.2% of rdg + 4°C) 400 to 700°C: ±8°C accuracy less than 400°C not specified
W	0.0 to 2300.0°C	± (0.2% of rdg + 3°C)

<sup>1</sup> under standard operating conditions

**Reference junction compensation accuracy** ±1°C (input terminal temperatures are balanced)  
±1.5°C (R, S, B, W)

**Input coupling** DC

**Frequency bandwidth (filters off)**

DC coupling input  
TC input

DC - 40kHz (+1dB, -3dB, Typical)  
DC - 6Hz (+1dB, -3dB, Typical)

**A/D resolution** 14 bit

**Maximum sampling rate**

100kS/sec  
For TC input : Sample rate is 135 Hz, regardless of the sample rate setting.

**Maximum input voltage**

30 Vrms AC or 60 VDC

**Input impedance**

1MΩ ± 1%

**Noise**

200µVp-p(Typical) for 50mV input, short circuit input

<b>Maximum floating voltage</b>	30 Vrms or 60 VDC (in accordance with safety standards); 250 Vrms AC (common mode rejection ratio is satisfied), between input terminal and case and between each channel
<b>Normal mode rejection ratio</b>	50dB (50/60Hz, with 1.5Hz filter ON)
<b>Common mode rejecton ratio</b>	More than 120dB (50/60Hz, with 1.5Hz filter ON, signal source resistance less than 500Ω) 80dB (50/60Hz, with 1.5Hz filter OFF, signal source resistance less than 500Ω)
<b>Temperature coefficients</b>	
Zero point	Automatically calibrated before measurement, and 0.02% of measurement range/°C thereafter
Gain	0.02% of measurement range/°C after auto calibration
<b>Filter</b>	Line filter, lowpass filter, filter ON/OFF
Cutoff frequency	Line filter           1.5Hz Lowpass filter       40Hz, 400Hz, 4kHz
Filter characteristics	
Line filter	Normal mode rejection ratio -50dB (50/60Hz) Common mode rejection ratio -120dB (50/60Hz)
Lowpass filter	-12dB/octave
<b>Input terminals</b>	Binding post type
<b>Weight</b>	approx. 180 gr.
<b>RMS Converter Unit (783053)</b>	
Number of channels	1/unit
Input Type	Floating, unbalanced, isolated channels
Input coupling	DC
Measurement function	DC measurement/RMS convert switchable
A/D resolution	12 bit
Maximum sampling rate	100kS/sec
Maximum input voltage	350 VDC + ACpeak
Input impedance	1MΩ ± 1%
Noise	500μVp-p(Typical), for 100mV input, short circuit input
Maximum floating voltage	350 VDC + ACpeak (between input terminal and case, between all channels)
Common mode rejection ratio	More than 80dB (50/60Hz, signal source resistance less than 500Ω)
<b>Temperature coefficients</b>	
Zero point	Automatically calibrated before measurement (DC model only)*, and ±0.03% of range/°C thereafter
Gain	±0.02% of range/°C
<b>Input terminals</b>	Safety terminals (Bananaclip type)
<b>Weight</b>	approx. 170 gr.
<b>Accessories</b>	Measurement leads (1/unit)
* In case of RMS converter mode, the default calibration values or manually set calibration values are used.	
<b>• DC Measurement Mode</b>	
Frequency bandwidth (filters off)	DC-40kHz (+1dB, -3dB, Typical)
Measurement range & accuracy	As shown below (filter off, at 23±5°C)



Measurement Range	Actual Measurement Range	Accuracy
500 V	±350.0 V	±(0.5% of meas. range)
200 V	±200.0 V	±(0.5% of meas. range)
100 V	±100.0 V	±(0.5% of meas. range)
50 V	±50.00 V	±(0.5% of meas. range)
20 V	±20.00 V	±(0.5% of meas. range)
10 V	±10.00 V	±(0.5% of meas. range)
5 V	±5.000 V	±(0.5% of meas. range)
2 V	±2.000 V	±(0.5% of meas. range)
1 V	±1.000 V	±(0.5% of meas. range)
500 mV	±500.0 mV	±(0.5% of meas. range)
200 mV	±200.0 mV	±(0.5% of meas. range)
100 mV	±100.0 mV	±(0.5% of meas. range)

**Filter** Lowpass filter, ON/OFF  
Cutoff frequency  
Filter characteristics

10Hz, 100Hz, 1kHz  
-12dB/octave

**•RMS Converter Mode**  
**Frequency bandwidth**  
**Measurement range & accuracy**

DC, 40Hz-10kHz  
As shown below (Frequency bandwidth : DC, 40Hz-1kHz, at 23±5°C)

Measurement Range	Actual Measurement Range	Accuracy
500 V	0 to 350.0 Vrms	For crest factor 3: ±3% of range
200 V	0 to 200.0 Vrms	
100 V	0 to 100.0 Vrms	
50 V	0 to 50.00 Vrms	
20 V	0 to 20.00 Vrms	
10 V	0 to 10.00 Vrms	
5 V	0 to 5.000 Vrms	For crest factor 2: ±2% of range
2 V	0 to 2.000 Vrms	
1 V	0 to 1.000 Vrms	
500 mV	0 to 500.0 mVrms	
200 mV	0 to 200.0 mVrms	
100 mV	0 to 100.0 mVrms	

However, do not input any voltage exceeding the max. input voltage

**Response speed**  
Rising signal  
Falling signal

: 100ms (typical), however 0-90% of Range  
: 200ms (typical), however 100-10% of Range

**Crest factor**

3

**Strain Input Unit (783054(120Ω), 783054/R3(350Ω))**

**Number of channels**

1/unit

**Input Type**

Balanced, diferencial, Floating, isolated channels

**Measurement function**

Strain measurement / DC measurement mode switchable

**Frequency bandwidth**

DC-20kHz

**A/D resolution**

14 bit

**Maximum sampling rate**

100kS/sec

**Maximum input voltage**

10 VDC + ACpeak

**Noise**

20μVp-p(Typical), for 1mV input, short circuit input

**Maximumfloating voltage**

30 Vrms AC or 60VDC (value conform safety standard)  
250 Vrms AC (value in accordance with Common mode rejection ratio)  
between input terminal and case, between all channels



**Common mode rejection ratio** More than 80dB (50/60Hz, signal source resistance less than 1kΩ)

**Temperature coefficients**

Strain measurement mode  
 Zero point  $\pm 5\mu\epsilon / ^\circ\text{C}$   
 Gain  $\pm 0.1\%$  of range/ $^\circ\text{C}$   
 automatically balanced, 1 gauge, without strain gauge temperature coefficients  
 DC measurement mode  
 Zero point  $\pm 2.5\mu\text{V} / ^\circ\text{C}$   
 Gain  $\pm 0.1\%$  of range/ $^\circ\text{C}$

**Filter** Lowpass filter, filter ON/OFF  
 Cutoff frequency 10Hz, 100Hz, 1kHz  
 Filter characteristics -12dB/octave

**Input terminals** 8 pin DIN connector (female)

**Weight** approx. 170 gr.

**Accessories** 8 pin DIN connector (male)

**Optional accessories** DIN-NDIS cable

**•Strain Measurement Mode  
 Measurement method**

DC bridge with 120Ω (783054) or 350Ω (783054/R3) built-in resistor

**Measurement range & accuracy**

As shown below (filter off, balanced, at 23±5°C)

Measurement Range	Actual Measurement Range	Accuracy
1000μϵ	±1000μϵ	±(2.5% of Range +50μϵ)
2000μϵ	±2000μϵ	±(1.5% of Range +50μϵ)
5000μϵ	±5000μϵ	±(1.0% of Range +50μϵ)
10000μϵ	±10000μϵ	±(1.0% of Range +50μϵ)
20000μϵ	±20000μϵ	±(1.0% of Range +50μϵ)

**Adjustive excitation method** 1,2,4 gauge

**Gage resistance** 120-1000Ω (bridge voltage 2, 3 V)  
 350-1000Ω (bridge voltage 5, 10 V)

**Gage factor** 2 (only for hard ware, can be adjusted using OR1400 (783001)'s scaling function)

**Bridge excitation voltage** 2,3,5,10 V

**Strain balance** Electronic auto balance  
 Balance range  $\pm 10000 \mu$  strain (Typical)  
 Remaining voltage  $\pm 10\mu\epsilon$   
 Balance time Within 0.5 seconds  
 Balance mode All channels together or each channel separately

**•DC Measurement Mode  
 Measurement method**

Differential DC amplifier

**Measurement range & accuracy**

As shown below (filter off, at 23±5°C)

Measurement Range	Actual Measurement Range	Accuracy
1 mV	±1.000 mV	±(1.5% of Range +35μV)
2 mV	±2.000 mV	±(1.0% of Range +35μV)
5 mV	±5.000 mV	±(1.0% of Range +35μV)
10 mV	±10.000 mV	±(1.0% of Range +35μV)
20 mV	±20.00 mV	±(1.0% of Range +35μV)



**Frequency Input Unit (783055)****Number of channels**

1/unit

**Input**

Floating, unbalanced, isolated channels

**Measurement range & accuracy**

As shown below (at 23±5°C)

Measurement Range	Actual Measurement Range	Accuracy	Minimum Setting Span
50Hz	40.00 to 60.00Hz	±0.05Hz	2.00Hz
60Hz	50.00 to 70.00Hz	±0.05Hz	2.00Hz
100Hz	0.00 to 100.00Hz	±(0.2% of F.S.)	10.00Hz
200Hz	0.0 to 200.0Hz	±(0.2% of F.S.)	20.0Hz
500Hz	0.0 to 500.0Hz	±(0.2% of F.S.)	50.0Hz
1000Hz	0.0 to 1000.0Hz	±(0.2% of F.S.)	100.0Hz
2000Hz	0 to 2000Hz	±(0.2% of F.S.)	200Hz
5000Hz	0 to 5000Hz	±(0.2% of F.S.)	500Hz
10000Hz	0 to 10000Hz	±(0.2% of F.S.)	1000Hz

**Input coupling**

AC

**Frequency bandwidth**

1Hz-10kHz

**Measurement waveform**

Sine wave and pulse wave

**Data sampling time**

2.291ms (although sampling rate)

**Input voltage range**

1-30 Vp-p

**Maximum input voltage**

30 Vrms AC or 60 VDC

**Input impedance**

102kΩ ± 1%

**Maximum floating voltage**

30 Vrms AC or 60VDC (between input terminal and case, between all channels)

**Response time**

2 Pulse + 50ms (DC offset voltage, however, in case of changing DC offset, 1.5 sec must be added)\*

**Duty ratio**

50% ± 30%

**Input terminals**

Binding post type

**Weight**

approx. 170 gr.

\* The internal circuitry of the freq. input unit operates in such a way that the oscillation of the DC offset voltage seems like a rising or falling signal of a pulse wave. Therefore, when the DC offset voltage of the input signal alters and exceeds the threshold level, the measurement values might be inaccurate. In this case, the response time increases.

**Power Line Freq. Input Unit (783056)**

Number of channels 1/unit

Input Floating, unbalanced, isolated channels

Measurement range &amp; accuracy As shown below (at 23±5°C)

Measurement Range	Actual Measurement Range	Accuracy	Minimum Setting Span
50Hz	40.00 to 60.00Hz	±0.05Hz	2.00Hz
60Hz	50.00 to 70.00Hz	±0.05Hz	2.00Hz
100Hz	0.00 to 100.00Hz	±(0.2% of F.S.)	10.00Hz
200Hz	0.0 to 200.0Hz	±(0.2% of F.S.)	20.0Hz
500Hz	0.0 to 500.0Hz	±(0.2% of F.S.)	50.0Hz
1000Hz	0.0 to 1000.0Hz	±(0.2% of F.S.)	100.0Hz
2000Hz	0 to 2000Hz	±(0.2% of F.S.)	200Hz
5000Hz	0 to 5000Hz	±(0.2% of F.S.)	500Hz
10000Hz	0 to 10000Hz	±(0.2% of F.S.)	1000Hz

Input coupling AC

Frequency bandwidth 1Hz-10kHz

Measurement waveform Sine wave and pulse wave

Data sampling time 2.291ms (although sampling rate)

Input voltage range

Sine wave 30-240 V rms  
Pulse wave 85-670 Vp-p  
maximum input voltage

Maximum input voltage 350 VDC + ACpeak

Input impedance 1.01MΩ ± 1%

Maximum floating voltage 350 VDC + ACpeak (between input terminal and case, between all channels)

Response time 2 Pulse + 50ms (DC offset voltage, however, in case of changing DC offset, 1.5 sec must be added)\*

Duty ratio 50% ± 30%

Input terminals Safety terminals (Bananaclip type)

Weight approx. 170 gr.

Accessories Measurement leads (1/unit)

\* The internal circuitry of the power line freq. input unit operates in such a way that the oscillation of the DC offset voltage seems like a rising or falling signal of a pulse wave. Therefore, when the DC offset voltage of the input signal alters and exceeds the threshold level, the measurement values might be inaccurate. In this case, the response time increases.

## 12.2 Recording

<b>Printer type</b>	Thermal printer (dot overlap)
<b>Recording functions</b>	
real-time recording	T-Y, X-Y, numeric value recording
captured data recording	T-Y, X-Y, numeric value recording, A4/A5 format recording, mathematical computations
<b>Recording/Printing</b>	Measurement data, captured data, setup list, unit, scale, text (message), time tick, event marker, grid, channel number, etc.
header	60 characters/channel plus time or channel information (input range, scale), will be printed every 200mm
CH annotations	Measurement values (numeric values), message (60 characters) or channel information (range, span, filter) printed every 200 mm.
manual printout	Measurement values are printed up to 10 mm/s chart speed.
Event messages	Measurement values (numeric) and time printed (on key command or by remote input, up to 10 mm/s chart speed)
Time ticks	five types, 16 characters each, printed on key command or remote input with time (up to 100 mm/s chart speed)
Event Marker	Printed every 0.01, 0.1, 1, 10 or 60 seconds (cannot be used in combination with event markers)
Grid	Printed by remote input (cannot be used in combination with time ticks)
Channel number	OFF, 10 mm Fine, 10 mm Simple, 10 Div Fine (time axis 10 mm Fine), 10 Div Simple (time axis 10 mm Simple), shading selectable
List	Printed at 200xn intervals (n=1, 2, 5, 10) at chart speed up to 100 mm/s Prints a list of the set parameters
<b>Recording width</b>	Maximum 201 mm
<b>Recording format</b>	
T-Y recording	8 zones of 20mm/zone 4 zones of 40mm/zone 2 zones of 80mm/zone 1 zone of 160mm or 200mm flexible zone: zone width can be set for each channel
X-Y recording	Single channel on the X-axis and up to four channels on the Y-axis
Digital recording	At a recording interval of 1, 2, 5, 10, 20, 30 or 60s
<b>Recording accuracy</b>	Measurement accuracy $\pm 0.125$ mm (1dot)
<b>Recording resolution</b>	8 dots/mm
<b>Time-axis resolution</b>	32 dots/mm for chart speeds up to 200 mm/s, 25.6 dots/mm for chart speed of 250 mm/s 8 dots/mm for X-Y recording
<b>Chart speed</b>	
real time recording	10, 25, 50, 100, 200, 250 mm/h 1, 2, 5, 10, 25, 50, 100, 200, 250 mm/min 1, 2, 5, 10, 25, 50, 100, 200, 250 mm/s V <sub>1</sub> , V <sub>2</sub> : 10 mm/h to 200 mm/s settable, not settable from 201 to 250 mm/h, mm/min, mm/s
printing captured data	50mm/s however, 25 mm/s in case of recording captured data in A4 format
<b>Shot recording</b>	Can be activated by trigger or by key operation, and prints out a previous set length automatically (only for real-time recording)
<b>Shot recording length</b>	0.2, 0.5, 1 or 2m
<b>Recording trace intensity</b>	Dark or light (except for X-Y recording)
<b>Chart paper</b>	Z-fold chart (approx. 210mm x 40m)

## 12.3 Data Capture

<b>Maximum memory size</b>	256kdata/ch, 1Mdata/ch (in case of 4 ch).
<b>Memory type</b>	DRAM
<b>Storage method</b>	
standard	Assigns maximum memory to each channel equally
re-allocated memory	The memory length of two or four channels can be combined. However, this imposes limits on the number of usable channels.
partitioned memory	Divides the memory for each channel into blocks, one for each channel event
number of memory blocks	1, 2, 4, 8, 16 (note that the memory length for each channel and the total memory capacity impose an upper limit on this number)
<b>Memory length setting</b>	1k, 2k, 4k, 8k, 16k, 32k, 64k, 128k, 256k, 512k <sup>1</sup> , 1M <sup>2</sup> <sup>1</sup> using only channels 1, 3, 5 and 7 <sup>2</sup> using only channel 1 and 5
<b>Sample rate</b>	0.1, 0.2, 0.5, 1, 2, 5, 10, 20, 50, 100, 200, 500, 1k, 2k, 5k, 10k, 20k, 50k, 100k S/sec or by external sampling clock; however, when real-time recording is in progress, the max. sample rate is 50k S/sec
<b>Time-axis accuracy</b>	±0.02%
<b>Captured data output</b>	Recording, display, floppy disk, communication
Recording scale change	Recording scale and zero position can be changed (except for computed data or data loaded from other instrument types)
Playback rate for analog recording	25, 50, 100, 200, 400, 1000, 2000, 5000 data/cm
Playback rate for digital recording	1, 2, 5, 10, 20, 50, 100 data/cm
cursor function	available (zoom on T-axis possible)
block setting	block number can be printed and recorded
recording span setting	by cursor or by numeric setting
<b>Auto Sequence functions</b>	All of the below-listed operations can be started after memory sampling ends (note that only auto-print is usable during real-time recording)
Auto print	Playback recording of captured data
Auto save	Saving captured data to floppy disk
Auto display	Displaying captured data
Accumulate	Overwrite display of captured data
Auto statistical computation	Automatic statistical computation processing of captured data, with recording or saving to floppy disk.
<b>Computation functions</b>	Four-function arithmetic between any two channels. When specifying computation, memory buffer for each channel must contain at least 50% free space. Any block of any channel can be displayed and recorded on the same time axis as a specified block from a specified channel.
<b>Statistical computation</b>	Statistical computation on any portion of any channel's data. In the auto mode, basic statistics for all channels will be computed. Types are: max, min, mean, RMS Time span is selected by rotary knob

## 12.4 Triggering

Trigger type	Window trigger, all channels trigger, external trigger
Trigger action	Real-time recording, data capture, chart speed change
Trigger mode	Single, repeat, free
Pre-trigger	0 to 100%
Post-trigger	-100 to 1000%
Trigger combination	AND, OR
Trigger level	Rise, fall, high, low (-100 to 100%)
Trigger output	Output to external terminal

## 12.5 Display

Displaying method	Scrolling from the top to the bottom of the screen
Screen	LCD (5inches)
Dot	320 x 240
Contents of the screen	Measurement data screen (waveform, numeric values), setting screen, span display
<b>Displaying format for measurement data</b>	
T-Y display	Displays waveforms of analog inputs (max 8ch). When equipped with the logic input option, analog waveforms and logic data will be displayed on two screens.
X-Y display	Displaying one of max. four waveforms (recording will be up to four waveforms). X-Y waveforms will only be displayed in case of displaying captured data; in case of real-time recording, the screen will show the T-Y display
Digital value display	Numeric display of measurement values (max. 8ch+logic channels)
Time axis of full-scale display	according to the formula $R=(D/P)/S$ , where D=200 (dots), P=dots/mm (i.e. 16 in case of chart speed of 100mm/s, otherwise 32), S=chart speed in mm/s. While digital recording, hard copy or scale printing is in progress: 250msec. While list printing is in progress: 125msec. While X-Y recording is in progress: 250msec for normal setting, 125msec for fast setting.
Play back rate of numeric values display	Will be updated approx. every 0.5s
Display lifetime	20.000 hours, under normal operating conditions

## 12.6 External I/O Signals

External trigger input	TTL level (pulse width more than 2 $\mu$ s)
External trigger output	TTL level (pulse width more than 2 $\mu$ s)
External clock	TTL level (up to max 100kHz, pulse width more than 2 $\mu$ s; however, when real-time recording is in progress, up to 50kHz)
Chart speed control	max. up to 25 mm/s TTL level (pulse width more than 2 $\mu$ s, max. pulse 800 Hz) V=f132 V=chart speed in mm/s; f=pulse frequency
Start/stop	Recording or/and data capture, or start event message (text and time) or manual printout (numeric printout of measurement values) TTL-levels (pulse width more than 2 $\mu$ s) start/stop : level-sensitive, active low initiate : edge-sensitive, active low
Event marker	TTL-levels (pulse width 200 $\mu$ s/min)

## 12.7 General Specifications

Number of analog channels	max. 8
Operating conditions	0 – 40°C, 30 – 80%RH (no condensation) In case of operating floppy disk : 5 – 40°C
Warm up time	At least 30 minutes
<b>Dielectric strength rating</b>	
between power supply and case	1500VAC for 1 minute
between input terminals and case	1500VAC for 1 minute
between input terminals	1500VAC for 1 minute
<b>Insulation resistance rating</b>	
between power supply and case	10M $\Omega$ (minimum) at 500VDC
between input terminals and case	10M $\Omega$ (minimum) at 500VDC
between input terminals	10M $\Omega$ (minimum) at 500VDC
Signal source resistance	Max. 500 $\Omega$
Magnetic field strength	Max. 400A/m 400A/m $\pm$ 1% (at smallest voltage range)
Momentary power loss rating	Less than 1 cycle (at 100VAC 50 Hz)
Position	Horizontal
Clock accuracy	$\pm$ 100ppm (typical)
Battery backup	For up to four setups and clock: lithium battery with a service life, at room temperature, of 10 years
Permissible power supply voltage	100–120VAC 50/60Hz or 200–240VAC 50/60Hz (to be specified by suffix code -1/-5)
Rated power supply voltage	100V type: 90–132V, 48–63Hz 200V type: 180–250V, 48–63Hz
<b>Power consumption</b>	
while chart recording	100V type: 300VA max. 150W max. 200V type: 360VA max. 150W max.
without chart recording	100V type: 140VA max. approx. 55W 200V type: 170VA max. approx. 55W

<b>Overall dimensions</b>	Approx. 320(W) x 220(H) x 434(D) mm
<b>Weight</b>	approx. 6.8kg (without chart and input units)
<b>Standard accessories</b>	Chart paper (Z-fold, 210 mm/40 m) Power cord Instruction manual Fuse (250V/4A timelag)
<b>Machine Noise</b>	Machine Noise Information Ordinance 3. GSGV, January 18, 1991: The maximum sound pressure level is equal or less than 60dB (A) according to ISO 7779.

## **12.8 3.5 Inch Floppy Disk**

<b>Number of drives</b>	1
<b>Data save format</b>	Ascii or Binary
<b>Kind of media</b>	2HD, 2DD
<b>Capacity</b>	720KB, 1.2MB, 1.44MB
<b>Memory data</b>	Selectable part of the waveform memory will be saved to the floppy disk
<b>Retrieving display</b>	By retrieving data, it is possible to display data as waveforms
<b>Dump function</b>	If data in memory exceeds floppy capacity, data is automatically partitioned for saving to multiple floppies

## **12.9 Options / Accessories**

<b>GP-IB interface</b>	
<b>Standard</b>	IEEE 488-1978
<b>Functions</b>	Setting parameters input/output, measurement values output (all settings other than power ON/OFF)
<b>RS-232-C interface</b>	
<b>Standard</b>	EIA RS-232-C
<b>Baud rate</b>	75, 150, 300, 600, 1200, 2400, 4800, 9600bps
<b>Functions</b>	Setting parameters input/output, measurement values output (all settings other than power ON/OFF)
<b>Logic input</b>	
<b>Number of channels</b>	16 (2x8)
<b>Probe</b>	702911 logic probe (8ch/probe)
<b>Input type</b>	Shared common within probe Floating between probe and recorder case TTL level or contact inputs (open/close)
<b>Maximum input voltage range</b>	±35VDC
<b>Trigger</b>	2source (8ch pattern trigger)
<b>Input impedance</b>	More than 10kΩ
<b>Threshold level</b>	TTL level
<b>Dielectric strength rating</b>	500VDC for 1 minute between probe and case



<b>Insulation resistance rating</b>	10 $\Omega$ minimum at 500VDC between probe and case
<b>External monitor interface</b>	
<b>Scan frequencies</b>	horizontal : 33.3 kHz vertical : 60.168 Hz
<b>Scan lines</b>	690x480 dots (however display resolution equivalent to 320 x 240 dots)
<b>Output signal</b>	video : 0.7 V <sub>p-p</sub> /75 $\Omega$ H-sync : TTL-level V-sync : TTL-level VGA compatible
<b>External keyboard interface</b>	
<b>Keyboard type</b>	IBM PC-AT or PS2 compatible keyboard
<b>Connector</b>	Round miniature DIN connector
<b>Input data</b>	Text entry function selection (excluding V <sub>1</sub> and V <sub>2</sub> , suppression voltage and range selection functions)
<b>Rackmounting hardware</b>	for JIS or ANSI
<b>Chart tray</b>	Z-fold chart tray (chart may sometimes not refold by itself at high chart speeds)

## 12.10 Warranted Characteristics-EMC and safety conformity standard

### Emissions Susceptibility

EN55011 Class A  
EN50082-2

IEC1000-4-2	Electrostatic Discharge 8kV(Air), 4kV(Contact)	Performance Criteria B
IEC1000-4-3	Radiated Susceptibility 80~1000MHz, 10V/m	Performance Criteria A*
IEC1000-4-4	Fast Transients AC Pow. Line 2kV, The other Lines 1kV	Performance Criteria B
IEC1000-4-6	Radiated Susceptibility 0.15~80MHz, 10V	Performance Criteria A*
IEC1000-4-8	Magnetic Susceptibility 50Hz, 30A/m	Performance Criteria A

\*Effect on accuracy

$\pm 10\%$  of range or  $\pm 100\text{mV}$  ; with 783051(Voltage Input Units) installed  
 $\pm 5\%$  of range or  $\pm 10\text{mV}$  ; with 783052(Universal Input Units) installed  
 $10\%$  of range or  $350\text{mVrms}$  ; with 783053 (RMS Converter Units) installed  
 $60\%$  of range or  $10000\mu\text{e}$  ; with 783054 (Strain Input Units) installed  
 $0.2\%$  of range or  $\pm 0.05\text{Hz}$  ; with 783055 (Frequency Input Units)  
and 783056 (Power Line Freq. Input Units) installed

### Safety

Approve CSA1010  
Self-certification to comply with IEC1010 recommendations.

## 12.11 External Dimensions

### OR1400

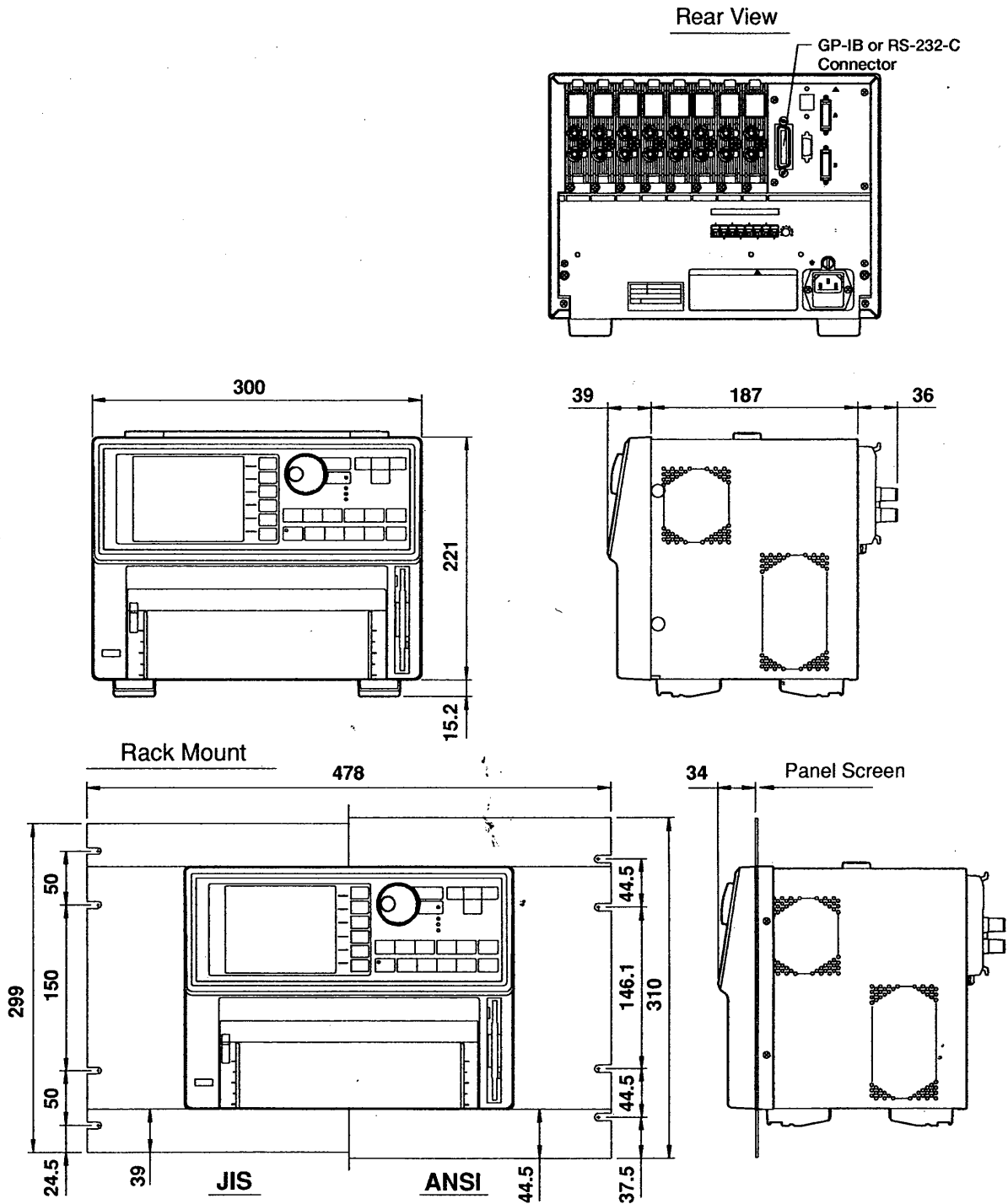

Unit : mm  
( Approx. inch )

If not specified, the tolerance is  $\pm 3\%$ . However, in cases of less than 10mm, the tolerance is  $\pm 0.3\text{mm}$ .

# Appendix A

## System Configuration & Block Diagram

### System Configuration

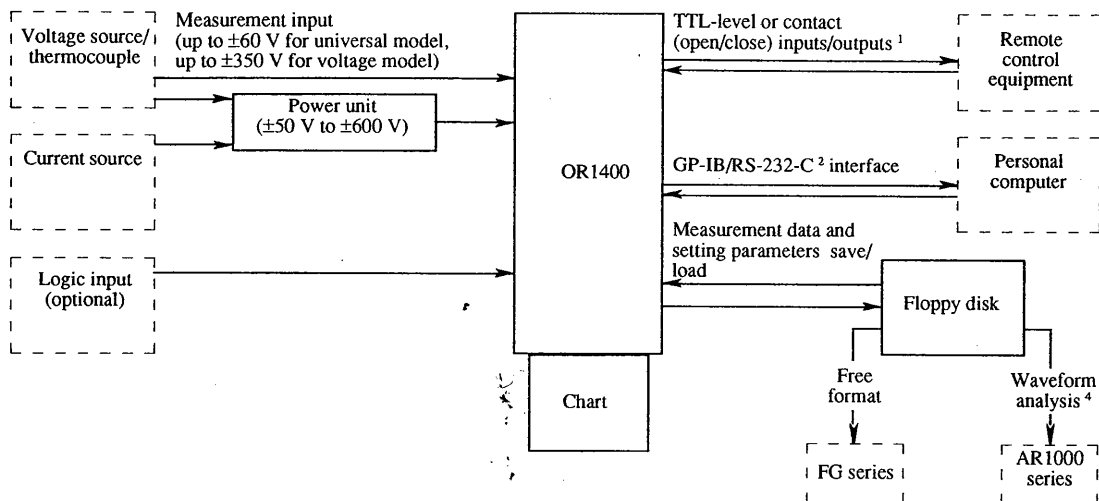

<sup>1</sup> For external trigger input/output, real-time recording start/stop control and external sampling clock.

<sup>2</sup> For remote control, measurement data and setting parameters conflict handling and error message handling.

<sup>3</sup> The power unit (model 365961) supports input voltages up to 600 V and input currents up to 10A.

<sup>4</sup> Analysis functions excluding FFT analysis and analysis by programming.

### Block Diagram

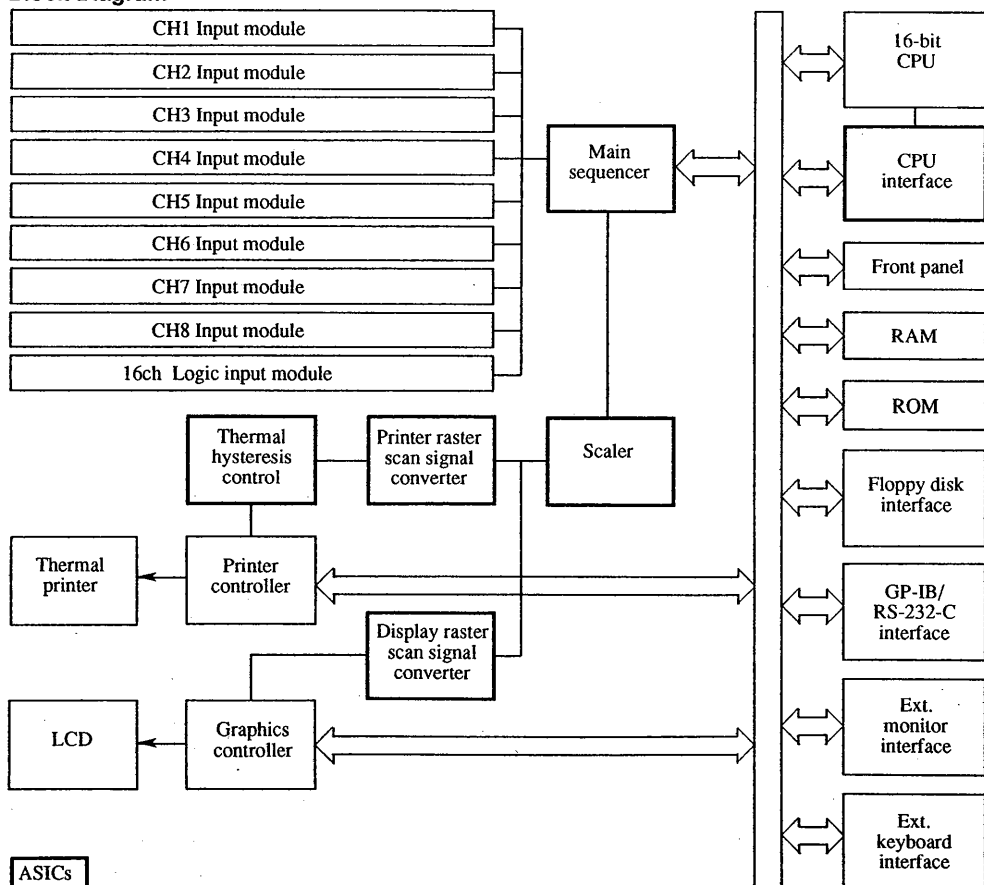

# Appendix B Initial Settings

This appendix supplies a list of the initial factory settings, in the format of the list printout.

1400

Feb.01.95 01:47:51

Chart speed : 10mm/s

App-2

Trace  Dark  Light

CH1 :   
 CH2 :   
 CH3 :   
 CH4 :   
 CH5 :   
 CH6 :   
 CH7 :   
 CH8 :

Flexible zone adjustment

CH	Upper	Lower
1	100	0%
2	100	0%
3	100	0%
4	100	0%
5	100	0%
6	100	0%
7	100	0%
8	100	0%

Misc

Alarm beep : On  
 External ST/SP : Record  
 Rec/Mem back up : Off  
 Chart clock : Internal  
 Ext. key board : ASCII

Range

CH	Input	Range	Filter	Scale	Units	Suppress
1	DC	10V	Off	5.000~-5.000	V	Off
2	DC	10V	Off	5.000~-5.000	V	-
3	DC	10V	Off	5.000~-5.000	V	-
4	DC	10V	Off	5.000~-5.000	V	-
5	DC	10V	Off	5.000~-5.000	V	-
6	DC	10V	Off	5.000~-5.000	V	-
7	DC	10V	Off	5.000~-5.000	V	-
8	DC	10V	Off	5.000~-5.000	V	-

Print format

Mode : Analog  
 Format : 8 Zone

Trigger : Window

Action : Memory  
 Mode : Free  
 Delay : 0% ( 0ms)  
 AND/OR : OR

Event message

#1 : [ ]  
 #2 : [ ]  
 #3 : [ ]  
 #4 : [ ]  
 #5 : [ ]

Print mode : Message

Span / Scale

CH	Scaling	Units	Pos.1		Pos.2	
			Volts/Temp	Scale	Volts/Temp	Scale
1	Off		0.000	0.000	2.000	2.000
2	Off		0.000	0.000	2.000	2.000
3	Off		0.000	0.000	2.000	2.000
4	Off		0.000	0.000	2.000	2.000
5	Off		0.000	0.000	2.000	2.000
6	Off		0.000	0.000	2.000	2.000
7	Off		0.000	0.000	2.000	2.000
8	Off		0.000	0.000	2.000	2.000

Grid intensity : Dark  
 Grid type : 10mm fine  
 Scale print : On  
 Annotation : Off  
 Channel print : On [400mm]  
 Header print : Time  
 Flexible zone : Off

Condition

No	CH	Slope	Level
1	Off		
2	Off		
3	Off		
4	Off		

RJC Check

CH : RJC

1 : Internal  
 2 : Internal  
 3 : Internal  
 4 : Internal  
 5 : Internal  
 6 : Internal  
 7 : Internal  
 8 : Internal

Shot recording : Off  
 Tick / Event : 1 [sec]

Logic

No	CH	1	2	3	4	5	6	7	8
5	Off								
6	Off								

Header & Annotation

H: [ ]  
 1: [ ]  
 2: [ ]  
 3: [ ]  
 4: [ ]  
 5: [ ]  
 6: [ ]  
 7: [ ]  
 8: [ ]

Memory format

Sample rate : 50kHz  
 Memory length : 1k ( 20.0ms)  
 No. of blocks : 1

Logic CH-A CH-B

Input	Print zone	On	Off	On	Off
Label	Bit 1	[A1]	[B1]		
	Bit 2	[A2]	[B2]		
	Bit 3	[A3]	[B3]		
	Bit 4	[A4]	[B4]		
	Bit 5	[A5]	[B5]		
	Bit 6	[A6]	[B6]		
	Bit 7	[A7]	[B7]		
	Bit 8	[A8]	[B8]		

Communication setting

<GP-IB>  
 Address : 1

Playback conditions

Auto mode : Off

Calculation : Off  
 Format : Strip chart  
 Expansion : 100 [Data/cm]  
 ( 5.0m/s )

Trigger print : On

Block printout : Current only  
 Data retrieve : Total

Retrieve calculation

CH	Mode	Units	Scale	
			Upper	Lower
1	Off	CH1 + CH2	5.000	-5.000
2	Off	CH1 + CH2	5.000	-5.000
3	Off	CH1 + CH2	5.000	-5.000
4	Off	CH1 + CH2	5.000	-5.000
5	Off	CH1 + CH2	5.000	-5.000
6	Off	CH1 + CH2	5.000	-5.000
7	Off	CH1 + CH2	5.000	-5.000
8	Off	CH1 + CH2	5.000	-5.000

# Appendix C

## English, German and French Displays

The following list shows the used vocabulary in the English displays with its equivalent in German and French. To change the language of the display, refer to 3.6.

	English	German	French
Range	Range	Bereich	Gamme
	Input	Eingang	Entrée
	DC	DC	DC
	HV	HV	HV
	RMS	RMS	RMS
	Strain	Strain	Jauge
	GND	GND	GND
	All adjust	All adjust	All adjust
	Adjust	Regelung	Reglage
	CAL	Kal.	CAL
	Type K	Typ K	Type K
	Suppress	Suppress	Suppress
	Filter	Filter	Filtre
	BV	BV	BV
	Utility	Diverses	Utilité
	Monitor	Monitor	Ecran
	Copy to	Kopie	Copier à
	Inverse	Invert.	Inverse
	Span Scale	Spanne Skala	Gain Echelle
	Auto scale	Auto Skala	Echelle auto
	Copy execute	Ausführen	Copier exécute
	BS	BS	BS
	DEL	DEL	DEL
	INS	INS	INS
	ESC	ESC	ESC
	Next	Next	Next
	On	Ein	On
	Off	Aus	Off
	CH	Ka	Vo
	Yes	Ja	Oui
	No	Nein	Non
	Enter	Eingabe	Entrer
	Setting	Eingabe	Choix
Chart speed	Chart speed	Papiervorschub	Vit. de papier
	V1	V1	V1
	mm/s	mm/S	mm/s
	mm/min	mm/M	mm/min
	mm/h	mm/U	mm/h
Span/Scale	Upper	Oben	Haute
	Lower	Unten	Basse
	Scaling	Skal. (Skalierung)	Echelle
	Units	Einheit	Unité
	Pos. 1	Pos. 1	Pos. 1
	Measure	Messung	Mesure
	Volts	Volt	Volt
	Temp	Temp. (Temperatur)	Temp.
	µε	µε	µε
	Frequency	Frequenz	Frequence
	Scale	Skala	Echelle
Trace	Trace	Spur	Trace
	Dark	Dunkel	Foncé
	Light	Hell	Clair

	English	German	French
<b>Print format</b>	Print format	Druckformat	Format d'impres.
	Mode	Modus	Mode
	Analog	Analog	Analogique
	Digital	Digital	Numerique
	Format	Format	Format
	2 Zone	2 Zonen	2 Zones
	X-Y	X-Y	X-Y
	Grid intensity	Helligkeit	Contrast grille
	Normal	Normal	Normal
	Grid type	Rastertyp	Type de grille
	10mm fine	10mm fein	10mm fine
	10mm Simple	10mm einfach	10mm simple
	Scale print	Skalenausdruck	Impress. échelle
	Annotation	Anmerkungen	Annotation
	CH. information	Ka. Information	Voie information
	Data Manual	Daten Manuell	Data manuelle
	Data Distance	Daten Abstand	Data interval
	Channel print	Kanalausdruck	Impress. voie
	Header print	Zusatzausdruck	Impress. titre
	Time	Zeit	Heure
	Comment	Kommentar (Komment.)	Commentaire
	Flexible zone	Zoneneinstell.	Zones flexibles
	Boundary	Begrenzt	Limites
	w/o Boundary	Unbegrenzt	Sans limites
	Shot recording	Einzelschuss	Monocoup papier
	Tick / Event	Mark. / Ereignis	Tick / Evénement
	1 sec	1 Sek	1 sec
	1 min	1 Min	1 min
	X- Axis	X-Achse	Axe X
	Graph	Graph	Graph.
	Time interval	Zeitintervall	Temps intervals
	Direction	Richtung	Sens
	180° rotation	180° Drehung	Rotation 180°
	Assign	Zuweisung	Desti.
<b>Memory format</b>	Memory format	Speicherformat	Mémorisation
	Sample rate	Abtastfrequenz	Vit. echant
	Memory length	Speicherlänge	Long de mémoire
	No. of blocks	Blockanzahl	Nombre de blocs
	Auto Mode	Auto-Modus	Mode automatique
	Print	Druck	Impress
	FDD	Floppy	Floppy
	Display	Anzeige	Affichage
	Accumulate	Akkumulieren	Accum.
	Statis.	Statistik (Statis.)	Statis.
	File	Datei	Fichier
	Auto statis CH	Auto-statis. Ka	Auto statis. Vo
	Calculation	Berechnung	Calcul
	Strip chart	Endlosausdruck	Longueur
	Full page (A4)	Ganzseite A4	Page (A4)
	1/2 Page (A5)	1/2 Seite A5	Page A5
	File	Datei	Fichier
	Expansion	Dehnung	Expansion
	File format	Datei format	Format fichier
	Trigger print	Triggerausdruck	Impress. trigger
	Block printout	Blockausdruck	Impress. blocs
	Current only	Aktuell Block	Dernier
	All blocks	Alle Blöcke	Tous les blocs
	Data retrieve	Daten Wiederher.	Data rappels
	Partial	Partiell	Partiel
	Total	Gesamt	Total
	Display area	Anzeigebereich	Partie affichée
	First	Erster	Début
	Last	Letzter	Fin
	Data Skip	Auslassen	Suppress. Data
	Playback conditions	Wiedergabe Bedingung	Rappels de condition
	Data/cm	Daten/cm	Data/cm

	English	German	French
Trigger	Trigger	Trigger	Trigger
	Window	Fenster	Fenêtre
	All Channels	Alle Kanäle	Toutes les voie(s)
	Action	Aktion	Action
	Memory	Speicher	Mémoire
	Record	Aufzeich (Aufzeichnen)	Papier
	Chart speed	Vorschub	Vit. de papier
	Free	Frei	Libre
	Single	Einzeln	Seul
	Repeat	Wiederh. (Wiederholend)	Répét. (Répétition)
	Sequence	Sequenz	Séquence
	Rotate	Rotier. (Rotierend)	Rotation
	Delay	Verzögerung	Retard
	AND/OR	AND/OR	ET/OU
	Slope	Flanke	Pente
	Rise	Rise	Rise
	Fall	Fall	Fall
	High	High	High
	Low	Low	Low
	Condition	Bedingung	Condition
	No	Nr	No
	Level	Wert	Niveau
Load/Save	Load/Save	Laden/Speichern	Charger/Sauver
	Media	Medium	Media
	Int. RAM	Int. RAM	RAM Int
	Function	Funktion	Fonctions
	Set 1	Satz 1	Choix 1
	Execute	Ausführen	Executer
	Panel	Einstel.	Panneau
	Dump	Dump	Dump
	Save (Binary)	Speich. (Binär)	Sauver Binaire
	Ascii	Ascii	Ascii
	Information	Information	Information
	Delete	Löschen	Effacer
	Retrieve	Wiedergabe	Rappeler
	Filename	Dateiname	Nom fichier
	Volume label	Diskettenname	Nom du volume
	Save Block	Speich. Block	Sauver bloc
	Option	Option	Option
	Set	Setzen	Choix
	Data save option	Speicheroption	Option sauvegarde
	Select save channels	Auswahl Speicher Kanäle	Choix de voies à sauver
	Set limit to save	Bedingung Datenspeicher	Choix data à sauver
Flexible zone	Flexible zone adjustment	Flex Zoneneinstellung	Position zones flexibles
	Flexible zone adjust	Flex. Zoneneinstellung	Position zones flexibles
	Upper	Oben	Haut
	Lower	Unten	Bas
Retrieve calculation	Retrieve calculation	Berechnung	Rappel pour calculs
	Upper scale	Obere Skala	Echelle haute
	Lower scale	Untere Skala	Echelle basse
	Print channel	Kanalausdruck	Impress. voie
	Block scale	Block Skala	Echelle de bloc
Comment	Header & Annotation	Zusatz & Anmerkungen	Titre & Annotation
	H (Header)	Z	T
	Copy to other channels	Kopie auf andere Kanäle	Copy des voies

	English	German	French
Logic	Logic Print zone Label Bit 1	Logik Druckzone Name Bit 1	Logiques Zone impress Nom Bit 1
System	System Date Time Event message Self test Initialize Misc Communication parameter	System Datum Zeit Ereignismeldung Selbsttest Initialisierung Diverses Schnittstelle	Système Date Heure Message événement Auto test Initialise Divers Config. de communication
Event message	Print mode Message Print	Druckmodus Meldung Drucken	Impression Message Impress
Selftest	TC GP-IB RS-232-C IBM Version Print head cleaning Key test Memory test RJC Check Ext. key	TC GP-IB RS-232-C IBM Version Druckkopfreinigung Tastaturtest Speichertest RJC Test Ext. Taste	TC GP-IB RS-232-C IBM Version Nettoyage tete impress Test touche Test mémoires Choix RJC Touche externe
System	Background Blue White Display language	Hintergrund Blau Weiß Menüsprache	Couleur écran Bleu Blanc Langue
Communication	Communication setting Address Baud rate Datalength Parity Odd Even None Stop bit Handshaking	Schnittstelle Adresse Baud rate Datenlänge Parität Odd Even None Stopbit Handshaking	Config. de communication Adresse Vit. transfert Taille fichier Paritee Odd Even None Bit d'arret Handshaking
Misc	Alarm beep External ST/SP Record Memory Rec.&Mem. Rec/Mem back up Chart clock Internal External Ext. key board Hard copy mode	Alarmton Extern ST/SP Aufzeichnen Speichern Aufz.&Sp. Aufz./Sp. back up INT/EXT Uhr Intern Extern Ext. Tastatur Hard copy Modus	Buzzer ST/SP Externe Papier Mémoire Pap&Mém Sauvegarde Pap/Mém Horloge temps pap Interne Externe Clavier externe Recopie



English	German	French
RJC		
Zerofix	Nullfix	Zérofixé
Cursor	Cursor	Curseur
Zoom	Zoom	Zoom
Print cond.	Druck Beding.	Cond. impress
Statis calc	Statis Berech.	Calculs. Statis.
Change scale	Skala Änderung	Change. échelle
Zoom Up	Zoom auf	Zoom
Zoom down	Zoom ab	Zoom
Ref. On/Off	Ref. Ein/Aus	Ref. On/Off
Reset	Reset	Remise
Block change	Block Änderung	Change. block
Memory block	Speicherblock	Bloc de mémoire
Time of trigger	Triggerzeit	Temps de trigger
Not exist	Nicht anwesend	N'existe pas
Scale of stored data	Skala der gespeicherte Data	Echelle de data sauvés
Freeze	Anhalten	Pause
Manual print	Manuell Ausdruck	Impress Manuelle
LCD contrast	LCD Kontrast	LCD contraste

# Index

180° ..... 4-12

## A

A/D converter ..... 1-1  
accessories ..... 3  
action  
    see trigger action  
actual measurement range ..... 3-4  
alarm beep ..... 9-4  
all blocks ..... 7-5  
all channels trigger screen ..... 6-2  
analog waveform  
    displaying captured data ..... 7-7  
    monitoring ..... 3-7  
    printing captured data ..... 7-1  
    real-time recording ..... 4-3  
    screen ..... 3-9, 7-7

## AND

    see trigger  
annotation  
    copying ..... 4-6  
    printing ..... 4-6  
    printout example ..... 1-4, 4-6  
    setting ..... 4-6  
automatic full-scale setting ..... 3-6  
auto mode function ..... 1-7, 7-4, 7-14,  
    8-7  
auto-print function ..... 1-7  
auto scale ..... 3-6

## B

background ..... 9-4  
backup  
    data ..... 9-4  
    after power failure ..... 3-1  
    setup ..... 9-12  
bi-slope  
    see trigger  
block  
    diagram ..... app. A  
    number ..... 7-5  
    printout ..... 7-5  
    setting ..... 5-2  
boundary ..... 4-4  
bridge excitation voltage ..... 2-6

## C

calculation  
    arithmetic ..... 7-11  
    statistical ..... 7-12  
calibration ..... 3-7  
captured data  
    displaying ..... 1-6  
    printing ..... 1-6  
channel indication ..... 7-7  
channel numbers  
    printing ..... 4-7  
    printout example ..... 1-4, 4-7  
chart speed  
    changing using external control ..... 9-7  
    key ..... 1-11

    printing ..... 4-8  
    printout example ..... 1-4, 4-8  
    setting ..... 4-3  
chart ..... 2-12  
chart tray ..... 2-13  
clamp filter ..... 2-11  
cleaning  
    instrument ..... 2-1  
    printer head ..... 11-2  
communication interface  
    GP-IB ..... 1-8, 1-12  
    RS-232-C ..... 1-8, 1-12  
computation  
    see calculation  
contrast controller ..... 1-10  
conversion adapter ..... 3  
copying  
    annotations ..... 4-6  
    settings ..... 3-8  
current only ..... 7-5  
cursor (zoom) ..... 7-8

## D

dark/light trace recording ..... 1-2, 4-9  
data capture  
    blocks ..... 1-6, 7-5  
    capabilities ..... 1-6  
    duration ..... 5-2  
    during real-time recording ..... 1-6, 7-4  
    memory coupling ..... 1-6, 5-2  
    memory length ..... 1-6, 5-2  
    number of memory blocks ..... 1-6, 5-3  
    sample rate ..... 1-6, 5-2  
    start/stop ..... 5-4  
    using an external control ..... 9-6  
data capture playback screen ..... 7-6  
data capture setting screen ..... 7-6  
data compatibility ..... 8-9  
data number ..... 7-2, 7-4, 7-6  
data retrieve ..... 7-2, 7-3  
data skip ..... 7-3  
date and time  
    setting ..... 3-11  
    printing ..... 4-8  
    printout example ..... 1-4, 4-8  
default settings ..... app. B  
deleting measurement data  
    from floppy disk ..... 8-6  
deleting setups from floppy disk ..... 8-6  
digital display  
    of real-time recording ..... 4-11  
digital logging recording ..... 1-5, 4-11  
digital printout  
    of captured data ..... 7-3  
    of real-time recording ..... 4-11  
dimension  
    see external dimensions  
display ..... 1-10, 2-1  
displaying a block on the screen ..... 7-7  
displaying captured data on the screen  
    as analog waveforms ..... 7-7  
dump ..... 8-8

## E

effective chart speed ..... 7-2

entering	
characters .....	3-2
numeric values .....	3-2
settings .....	3-1
error messages .....	10-3
ESC key .....	7-8
event .....	2-7, 9-8
event marker .....	4-13, 9-8
event message	
printing .....	4-6
printout example .....	1-4, 4-6
setting .....	4-6
expansion .....	7-2
Ext. sample .....	2-7, 9-9
external dimensions .....	12-10
external input / output control	
data capturing .....	9-5
event message printing .....	9-5
external keyboard .....	1-12, 2-8
external monitor .....	1-12, 2-8
external sampling clock .....	1-8, 9-9
external trigger input .....	1-8, 9-6, 9-7, 9-8
external trigger output .....	1-8, 9-10
manual printout .....	9-6
recording .....	9-6
setting .....	9-6
signal cables .....	2-4
external trigger	
see trigger	

## F

FDD save .....	7-7, 8-5
features .....	1-1
feeding the chart .....	1-11
file format .....	7-2, 9-5
file name .....	8-2, 8-3
filter	
setting .....	3-3
type .....	3-3
fixed zone recording .....	1-2, 4-4
flexible zone adjust screen .....	4-5
flexible zone recording .....	1-2, 4-4
floppy disk	
deleting files from .....	8-6
formatting .....	8-1
loading from .....	8-5
saving .....	8-2, 8-3
usable disks .....	8-1
flow chart	
see operation flowchart	
formatting floppy disk .....	8-1
free	
see trigger mode	
freezing the monitor screen .....	3-10
full-scale span .....	3-4
full-scale values	
automatic setting .....	3-6
initial .....	3-4
resetting .....	3-6
setting .....	3-5
functions .....	1-1
fuse	
location .....	1-12
parts number .....	3
replacement .....	11-3

## G

gage .....	2-6
GP-IB connector .....	1-12
grid intensity .....	4-5
grid type .....	4-5
grounding function terminal .....	1-12

## H

hard copy .....	1-8, 9-5
header	
entering .....	4-8
printing .....	4-8
printout example .....	1-4, 4-8

## I

initial full-scale values .....	3-4
initial settings	
data capture .....	5-1
default settings .....	app. B
recording .....	4-1
triggering .....	6-1
initializing	
memory .....	9-3
setups .....	9-3
input	
capabilities .....	1-1
filters .....	1-1, 3-3
setting screen .....	3-1
input unit	
installing .....	2-3
removing .....	2-3
input signals	
channel off .....	3-3
DC .....	3-3
ground .....	3-3
input types .....	3-3
logic input .....	3-3
settings .....	3-3
thermocouple input .....	3-3
installation site .....	2-2
inverted recording .....	1-3, 4-10

## K

keyboard .....	1-12, 2-9
keys	
CH .....	1-11
Chart speed .....	1-11
cursor .....	1-10
Display .....	1-11
Feed .....	1-11
hard copy .....	1-11
List .....	1-11
Local .....	1-11
Memory print .....	1-11
Memory start/stop .....	1-11
Menu .....	1-11
Monitor .....	1-11
Record start/stop .....	1-11
Shift .....	1-11
testing .....	11-1

## L

- language ..... 1-8, 3-10
- LCD contrast controller ..... 1-10
- linear scaling ..... 1-8, 9-1
- list
  - see setup list
- loading chart ..... 2-10
- loading measurement data
  - from floppy disk ..... 8-5
- loading setups from floppy disk ..... 8-5
- logic input
  - connector ..... 3
  - signals ..... 2-8
  - connecting ..... 2-8
- logic probe ..... 3
- logic recording ..... 4-13

## M

- malfunction ..... 2-1
- manual printout ..... 3-10
- mathematical function
  - see calculation
- maximum full-scale spans ..... 3-4
- measurement data
  - file info ..... 8-6
  - deleting files ..... 8-6
  - loading files ..... 8-5
  - range setting ..... 3-4
  - saving files ..... 8-3
- measurement function ..... 9-2
- measurement input
  - cable ..... 3
  - input types ..... 1-1, 3-3
  - thermocouple input types ..... 1-1, 3-3
  - voltage input range ..... 3-4
- measurement range setting ..... 3-4
- memory
  - blocks ..... 5-3
  - coupling ..... 1-6
  - format screen ..... 5-1
  - information ..... 8-6, 9-11
  - length ..... 5-2, 7-7
  - partitioning ..... 5-3
  - position indicator ..... 7-8
  - testing ..... 11-1
- message
  - see annotation, event message
  - see error messages
- model code ..... 2
- monitor ..... 1-12, 2-9
- monitor screen
  - analog waveform display ..... 1-5, 3-9
  - freezing ..... 3-10
  - full-scale values display ..... 1-5, 3-9
  - logic waveform display ..... 1-5
  - numeric values display ..... 1-5, 3-9
  - sequence ..... 3-9
  - switching between ..... 3-9
- monitor soft key ..... 3-9
- motor control ..... 2-7, 9-7

## N

- nameplate ..... 1-12

- nomenclature
  - front panel ..... 1-9
  - rear panel ..... 1-12
  - keys ..... 1-10
- number of the displayed block ..... 7-5
- numeric values
  - monitoring ..... 3-9
  - printing captured data ..... 7-4
  - real-time recording ..... 4-11
  - screen ..... 3-9

## O

- operating multiple recorders ..... 9-10
- operation flow chart ..... 1-13
- OR
  - see trigger
- orientation of the printout ..... 4-12

## P

- package contents ..... 3
- panel keys
  - see keys
- paper format ..... 1-6, 7-2
- parallel operating ..... 9-10
- playback rate ..... 7-2
- position ..... 3-5
- post-trigger
  - see trigger
- power cord and signal cables
  - connecting ..... 2-4
  - specifications ..... 2-4
- power switch
  - location ..... 3-1
  - switching on/off ..... 3-1
- power unit ..... 3
- pre-trigger
  - see trigger
- print format screen ..... 4-1
- printer head
  - cleaning ..... 11-2
  - precautions ..... 2-1
- printing
  - captured data blocks ..... 7-5
  - conditions ..... 7-2
  - setups ..... 1-8, 9-5

## R

- rack mounting ..... 2-4
- range setting
  - see measurement range setting
- readout cursor ..... 7-8
- real-time
  - capabilities ..... 1-2
  - recording ..... 4-1
- recording
  - format ..... 4-1
  - starting / stopping ..... 4-3
- recording example
  - annotation ..... 1-4, 4-6
  - channel number ..... 1-4, 1-5, 4-7
  - chart speed ..... 1-4, 4-8
  - date and time ..... 1-4, 1-5, 4-8
  - event message ..... 1-4, 4-6
  - grid ..... 1-4, 4-5
  - header ..... 1-4, 4-8

scale .....	1-4
recording example of captured data	
effective chart speed .....	1-6, 7-2
time scale .....	1-6, 7-2
trigger date and time .....	1-6, 7-2
trigger mark .....	1-6, 7-2
recording position	
see position	
reference cursor .....	7-8
repeat	
see trigger mode	
resetting	
control settings .....	9-3
full-scale values .....	3-6
memory .....	9-3
RMS mode .....	7-12
ROM/RAM test .....	11-1
rotary knob testing .....	11-1
RS-232-C connector .....	1-12

## S

sample rate .....	5-2
sampled by .....	8-6
sampling conditions checking .....	9-11
saving	
measurement data to floppy disk .....	8-3
setups .....	9-12
setups to floppy disk .....	8-2
scale	
printing .....	4-8
printout example .....	1-4
scaling	
see linear scaling	
selecting a block to print from .....	7-5
selecting a section of the captured data .....	7-6
selecting settings	
cursor keys .....	3-2
rotary knob .....	3-2
soft keys .....	3-2
settings screen .....	3-1
setup	
list .....	9-5
loading backup .....	9-12
saving backup .....	9-12
shot recording	
see single shot recording	
single	
see trigger mode	
single-shot recording .....	1-3, 4-12
specifications .....	12-1
statistics .....	7-12, 7-14
strain balance .....	3-8
suffix code .....	2
suppression voltage .....	1-5, 3-6
system configuration .....	app. A
system settings .....	9-3

## T

T-Y recording .....	4-1
testing	
keys .....	11-1
memory .....	11-1
thermocouple accuracy .....	11-2
time scale .....	7-2
time series .....	7-12
time tick .....	4-13

trace intensity .....	4-9
trigger	
action .....	1-7, 6-3
AND/OR .....	1-7, 6-6
bi-slope .....	6-8
delay .....	1-7, 6-6
external .....	1-8, 6-2, 9-6, 9-7, 9-8
level .....	1-7, 6-7
logic .....	6-9
mark .....	7-1
mode .....	1-7, 6-4
point error .....	6-7
post- .....	1-7, 6-5
pre- .....	1-7, 6-5
print .....	7-2
slope .....	1-7, 6-7
source channels .....	1-7, 6-7
type .....	1-7, 6-2
trigger action	
chart speed .....	6-3
memory .....	6-3
record .....	6-3
trigger mode	
free .....	6-4
repeat .....	6-4
repeat rotate .....	6-5
repeat sequence .....	6-4
single .....	6-4
trigger screen .....	6-1
trigger type	
all channels .....	6-2
external .....	6-2
window .....	6-2
triggering	
see trigger	
trouble shooting .....	10-1

## U

usable floppy disk .....	8-1
utility command .....	3-9, 8-1

## V

ventilation .....	2-1
volume label .....	8-1

## W

window trigger screen .....	6-2
-----------------------------	-----

## X

X-Y	
printout example .....	1-3
recording .....	4-10

## Z

zero fix .....	11-2
zone recording .....	4-4
zone adjusting	
lower .....	4-4
upper .....	4-4
zoom rate .....	7-8
zoom up/down keys .....	7-8
zooming in .....	7-8

**YOKOGAWA** ◆

Yokogawa Electric T&M www server  
//www.yokogawa.co.jp/tm/

**YOKOGAWA ELECTRIC CORPORATION**

**Headquarters**

9-32, Nakacho 2-chome, Musashino-shi, Tokyo, 180-8750 JAPAN

**Measurement Sales Dept./Recorders • DAC Sales Dept.**

9-32, Nakacho 2-chome, Musashino-shi, Tokyo, 180-8750 JAPAN

Measurement Phone : 81-422-52-6614 Fax : 81-422-52-6624

Recorders • DAC Phone : 81-422-52-6765 Fax : 81-422-52-6793

**Branch Sales Offices**

Nagoya, Osaka, Okayama, Fukuoka, Sapporo, Sendai, Ichiyama, Kanazawa, Toyoda, Kobe, Hiroshima, Takamatsu and Kitakyusyu.

**Overseas Representative Office / Service Centers**

Beijing, Shanghai (The People's Republic of China)

**YOKOGAWA CORPORATION OF AMERICA**

**Headquarters**

2 Dart Road, Newnan, Ga. 30265-1094, U.S.A.

Phone : 1-404-253-7000 Fax : 1-404-251-2088

**Branch Sales Offices** / Santa Fe Springs, Mentor, Murrietta, Houston, San Jose, Chagrin Falls, Elk Grove Village, Cypress, Hope Valley

**YOKOGAWA INDUSTRIAL AUTOMATION AMERICA**

**Headquarters**

4 Dart Road, Shenandoah Industrial Park, Newnan, Ga. 30265-1040, U.S.A

Phone : 1-404-254-0400 Fax : 1-404-251-6427

**Branch Sales Offices** / Rutherford, Houston, Bensenville, Carrollton, Anaheim

**YOKOGAWA EUROPE B. V.**

**Headquarters**

Radiumweg 30, 3812 RA, Amersfoort, THE NETHERLANDS

Phone : 31-33-641611 Fax : 31-33-631202

**Branch Sales Offices** / Maarsse (Netherlands), Graz (Austria), Antwerpen (Belgium), Buc (France), Herrsching (Germany), Bucks (United Kingdom), Milano (Italy), Madrid (Spain), Bronby (Denmark), Espoo (Finland), Athens (Greece), Oslo (Norway), Lisboa (Portugal), Solna (Sweden), Uitikon (Switzerland)

**YOKOGAWA ELECTRICA DO BRASIL IND. E COM. LTDA.**

Praca Acapulco, No.31 Parque Industrial Jurubatuba, CEP 04675 Santo Amaro-Sao Paulo, SP BRAZIL

Phone : 55-11-548-2666 Telex : 38-1157755 YOKO BR

Fax : 55-11-522-5231

**YOKOGAWA ENGINEERING ASIA PTE. LTD.**

11 Tampines Street 92, Singapore 1852, SINGAPORE

Phone : 65-783-9537 Fax : 65-786-6650

Telex : RS87-26137 YASSIN

**YOKOGAWA MEASURING INSTRUMENTS KOREA CORPORATION**

(City Air Terminal Bldg. 407 / 408) 159-6 Samsung-Dong, Kangnam-ku, Seoul, KOREA

Phone : 82-2-551-0660 to -0664 Fax : 82-2-551-0665

**YOKOGAWA AUSTRALIA PTY. LTD.**

**Head Office**

Private mail bag 24, Centre Court D3, 25-27 Paul Street North, North Ryde, N.S.W.2113, AUSTRALIA

Phone : 61-2-805-0699 Fax : 61-2-888-1844

**YOKOGAWA BLUE STAR LTD.**

**Headquarters**

40 / 4 Lavelle Road Bangalore 560 001, INDIA

Phone : 91-812-211513 Fax : 91-812-214270

Telex : 81-8458702 YKCO IN

May '98

<Recycled Paper Used>