

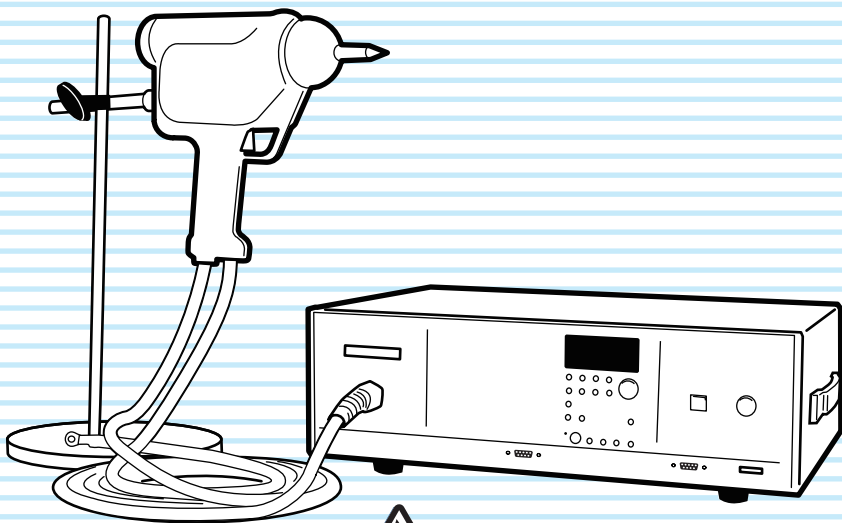

User's Manual

Electrostatic Discharge Simulator

KES4022A



DANGER

This product generates high voltage!

- Improper operation can lead to serious accidents.
- Keep this manual close to the product so that the operator can read it at anytime.

General Description

1

Installation and Preparation

2

Panel Operation Basics

3

Performing Discharge Testing

4

Performing Sequence Testing

5

Using the Application Software

6

Specifications

7

App

Thank you for purchasing the KES4022A Electrostatic Discharge Simulator.

About Operation Manual

The operation manual for the KES4022A is consisting of the "User's Manual"(this manual) and the "Communication Interface Manual".

User's manual (this manual)

The User's manual is intended for first-time users of this product. It provides an overview of the product and notes on usage. It also explains how to configure the product, operate the product, perform maintenance on the product, and so on.

The communication interface manual

The communication interface manual describes the content of the commands.

The interface manual is provided in HTML format on the supplied CD-ROM (a portion of the manual is in PDF format). You can view it using Microsoft Internet Explorer 5.5 or later. You can view the PDF file using Adobe Reader 6.0 or later.

Operation manual has been prepared with the utmost care; however, if you have any questions, or note any errors or omissions, please contact Kikusui distributor/agent.

If the operation manual gets lost or soiled, a new copy can be provided for a fee. In either case, please contact Kikusui distributor/agent, and provide the "Kikusui Part No." given on the cover page.

Trademark acknowledgements

Microsoft and Windows are registered trademarks of Microsoft Corporation in the United States and/or other countries.

Other company names and product names used in this manual are generally trademarks or registered trademarks of the respective companies.

Copyrights

The contents of operation manual may not be reproduced, in whole or in part, without the prior consent of the copyright holder.

The specifications of this product and the contents of operation manual are subject to change without prior notice.

© 2010 Kikusui Electronics Corporation

About this manual

Read this manual thoroughly to use the functions of the product effectively. You can also review this manual when you are confused about an operation or when a problem occurs.

After reading, always keep the manual nearby so that you may refer to it as needed. When moving the product to another location, be sure to bring the manual as well.

If you find any misplaced or missing pages in this manual, it will be replaced.

Product firmware versions that this manual covers

This manual applies to products with firmware versions 1.0X.

When contacting us about the product, please provide us with:

The model (marked in the top section of the front panel)

The firmware version (see page 25)

The serial number (marked in the bottom section of the rear panel)

How to read this manual

This manual is designed to be read from beginning to end. We recommend that you read it thoroughly before using this product for the first time.

Intended readers of this manual

This manual is intended for users of the product or persons teaching other users on how to operate the product.

The manual assumes that the reader has knowledge about electrical safety testing.

Notes to the supervisor

If the operators cannot understand the language used in this manual, translate the manual into the appropriate language.

Make sure that the operators understand the information in this manual before they operate this product.

Keep this manual close to the product so that the operators can read it at anytime.

Dangerous operations

You will receive a potentially fatal electric shock if:

- You touch the tip of the discharge gun while the KES4022A output is on.
- You touch the cup of the discharge gun while the KES4022A output is on.
- You touch the EUT while the KES4022A output is on.
- You touch a component that is electrically connected to the EUT immediately after the KES4022A output is stopped.

You may receive a potentially fatal electric shock if:

- You operate the KES4022A without grounding it.
- You go near a component that is electrically connected to the EUT while the KES4022A output is on.
- You go near a component that is electrically connected to the EUT immediately after the KES4022A output is shut down.

Conditions that can shorten the service life of the high-voltage switch

The high-voltage switch in the discharge gun that is used to generate discharges wears out over time. The high-voltage switch will wear out rapidly if you use the KES4022A:

- With a test voltage that exceeds the IEC test level.
- With the discharge interval set to less than 1 second.*1
- In conditions other than those specified for IEC or ISO standard testing.
- In combination with the optional C unit and discharge resistor.

*1. The mechanical life of the high-voltage switch is 1,000,000 operations. This calculates to about 14 hours of continuous operation if testing is performed using contact discharge at 20 pulses/second.

Safety Symbols

For the safe use and safe maintenance of this product, the following symbols are used throughout operation manual and on the product. Note the meaning of each of the symbols to ensure safe use of the product. (Not all symbols may be used.)

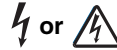

Indicates that a high voltage (over 1 000 V) is used here. Touching the part causes a possibly fatal electric shock. If physical contact is required by your work, start work only after you make sure that no voltage is output here.

DANGER

Indicates an imminently hazardous situation which, if ignored, will result in death or serious injury.



WARNING

Indicates a potentially hazardous situation which, if ignored, could result in death or serious injury.



CAUTION

Indicates a potentially hazardous situation which, if ignored, may result in damage to the product and other property.



Indicates a prohibited act.



Indicates a warning, caution, or danger. When this symbol is marked on the product, see the relevant section in this manual.



Protective conductor terminal.



Chassis (frame) terminal.



On (power supply).



Off (power supply).



In position of a bi-stable push control



Out position of a bi-stable push control

Notations used in this manual

- The KES4022A Electrostatic Discharge Simulator is also referred to as the KES4022A.
- The entire system that includes the main unit and the discharge gun is referred to as the product or the KES4022A.
- The discharge gun and the high-voltage cable are collectively referred to as the discharge gun.
- The panel control unit (everything except for the discharge gun) is referred to as the main unit.
- IEC 61000-4-2 Ed.2.0 2008-12 is referred to as the IEC 61000-4-2 standard.
- ISO 10605 Ed.2.0 2008-07 is referred to as the ISO 10605 standard.
- The following markings are used in this manual.

WARNING

Indicates a potentially hazardous situation which, if ignored, could result in death or serious injury.

CAUTION

Indicates a potentially hazardous situation which, if ignored, may result in damage to the product or other property.

NOTE

Indicates information that you should know.

DESCRIPTION

Explanation of terminology or operation principle.

See

Indicates reference to detailed information.

SHIFT+key name (marked in blue)

Indicates an operation that requires you to press a key indicated in blue letters while holding down the SHIFT key.



Safety Precautions

The following safety precautions must be observed to avoid fire hazards, electric shock, accidents, and device failures. Keep them in mind and make sure to observe them.

Using the product in a manner that is not specified in this manual may impair the protection functions provided by the product.



Users

- This product must be used only by qualified personnel who understand the contents of this operation manual.
- If an unqualified personnel is to use the product, be sure the product is handled under the supervision of qualified personnel (those who have electrical knowledge). This is to prevent the possibility of personal injury.
- If you have a heart condition, if you are pregnant or believe you may be pregnant, or if you use a pacemaker or other medical device, do not use this product.



Purpose of use

- Never use the product for purposes other than the product's intended use.
- This product is not designed or manufactured for general home or consumer use.

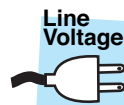

Input power

- Use the product within the rated input line voltage range.
- For applying power, use the power cord provided. For details, see the respective page in this manual.
- This product is an equipment of IEC Overvoltage Category II (energy-consuming equipment supplied from the fixed installation).



Cover

Some parts inside the product are hazardous. Do not remove the external cover.



Grounding

This product is IEC Safety Class I equipment (equipment with a protective conductor terminal). To prevent electric shock, be sure to connect the protective conductor terminal of the product to electrical ground (safety ground).

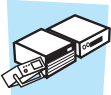

Installation

- This product is designed for safe indoor use. Be sure to use the product indoors.
- When installing this product, be sure to observe the precautions regarding the installation location. For details, see the respective pages in this manual.



Relocation

- Turn off the POWER switch, and disconnect the cables before relocating the product.
- When relocating the product, be sure to include the manual.



Operation

- Before use, visually check for problems in the power cord, discharge gun, and high-voltage cable. When checking for these problems, remove the power cord plug from the outlet.
- If you notice a malfunction or abnormality in the product, stop using it immediately, and remove the power cord plug from the outlet. Make sure the product is not used until it is completely repaired.
- Do not disassemble or modify the product. If you need to modify the product, contact your Kikusui distributor or agent.



Maintenance and inspection

- To prevent electric shock, be sure to unplug the product before carrying out maintenance or inspection. Do not remove the external cover.
- Check periodically that there are no tears or breaks in the power cord.
- If the panel needs cleaning, gently wipe it using a soft cloth with water-diluted neutral detergent. Do not use volatile chemicals such as benzene or thinner.
- To maintain the performance and safety of the product, we recommend periodic maintenance, inspection, cleaning, and calibration.



Service

Kikusui service engineers will perform internal service of the product. If the product needs adjustment or repairs, contact your Kikusui distributor or agent.



Discharge gun

- When the high-voltage indicator or DANGER indicator is illuminated, do not bring your hand close to the discharge tip or cup.
- Do not drop the discharge gun, CR unit, or discharge tips. If any of these are dropped, contact your Kikusui agent or distributor to arrange an inspection of the dropped component.

Contents

About this manual 2
Notes to the supervisor 3
Dangerous operations 3
Conditions that can shorten the service life of the high-voltage switch 3
Safety Symbols 3
Notations used in this manual 4
Safety Precautions 4
Contents 6
Search by Topic 7
Front panel 8
Discharge gun 10

1 General Description

Product Overview 12
Options 13

2 Installation and Preparation

Checking the Package Contents 18
Precautions about the Installation Location 19
Precautions for Moving the Product 20
Preparing the Discharge Gun 21
Connecting the Power Cord 24
Turning the power on 25
Steps to Be Taken in an Emergency 26

3 Panel Operation Basics

Selecting the Discharge Test 28
Selecting the Discharge Mode 29
Setting Test Voltages 30
Setting the Polarity 33
Setting the Number of Discharges 34
Setting the Discharge Interval 35
Setting the Discharge Points 36
Setting the Trigger Used to Start Testing 36
Configuring the Wait Feature 37
Specifying the CONFIG Settings 38
Other Settings 42

4 Performing Discharge Testing

Before Testing 46
Setting Test Conditions 47
Putting the KES4022A into standby 47

To Start Testing 48
To Pause and Redo Testing 52
Completion of Testing 52

5 Performing Sequence Testing

Sequence Operation Procedure 54
Starting Sequence Operation 55
Creating a New Step 56
Editing a Step's Testing Conditions 58
Copying a Step's Testing Conditions 59
Moving a Step's Position 60
Deleting Steps 60
Examples of How to Create Sequences 62
Starting Sequence Operation 66
Stopping Sequence Operation 68

6 Using the Application Software

Application Software Overview 70
Installing the Application Software 71
Configuring RS232C 72
Starting the Application 73
Configuring Manual Operation 74
Configuring IEC Test Level operation 76
Configuring Step Operation 78
Configuring Sequence Operation 80
Configuring Communication Settings 82
Saving and Loading Test Conditions 83
Communication with the KES4022A 86

7 Specifications

Appendix
A How Discharging Works 94
B List of Default Settings 95
C Troubleshooting 98
D Maintenance 99
E About Errors 104

INDEX 105

Search by Topic

Preparation



- What accessories are included in the package? → “Checking the Package Contents” p.18
- How do I change the CR unit? → “Checking and replacing the CR unit” p.21
- How do I replace the discharge tip? → “Attaching the discharge tip” p.22
- What are the different test types? → “Selecting the Discharge Test” p.28

Setup



- What are the voltages that are set for the different IEC test levels? → “Setting the IEC61000-4-2 test level (in manual or IEC test level operation)” p.31
- How do I set the step voltage? → “Setting step operation test voltages” p.32
- What polarity switch patterns can I use in automatic testing? → “Setting the Polarity” p.33
- How do I change the discharge counter mode and gun trigger mode? → “Specifying the CONFIG Settings” p.38
- How do I change the resolution when setting the test voltage or discharge count? → “Changing the Resolution” p.43
- What is the RS232C protocol that the KES4022A uses? → “Protocol” p.72
- How do I reset the KES4022A to its factory default settings? → “Initializing the KES4022A” p.95

Operation

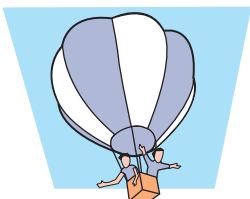

- How do I save the current test conditions and use them later? → “Storing test conditions to memory” p.40
- When a test is redone, which step does it restart from? → “Redoing a test” p.42
- How many times has the discharge gun's high-voltage switch been used? → “Displaying the number of times the high-voltage discharge switch has been used” p.43
- What kind of displays appear during sequence testing? What kind of buzzer sounds at the end of a step? → “Displayed information during testing” p.66
- How do I send the settings that I configured using the application to the KES4022A? → “Sending the test conditions that have been saved in the application to the KES4022A” p.86

Maintenance



- How do I inspect the KES4022A before testing? → “Preliminary inspection” p.23
- How should I clean the KES4022A and the discharge gun? → “Cleaning” p.99
- How do I calibrate the KES4022A? → “Calibration” p.101

To solve problems

See “Troubleshooting” on page 98.

Front panel

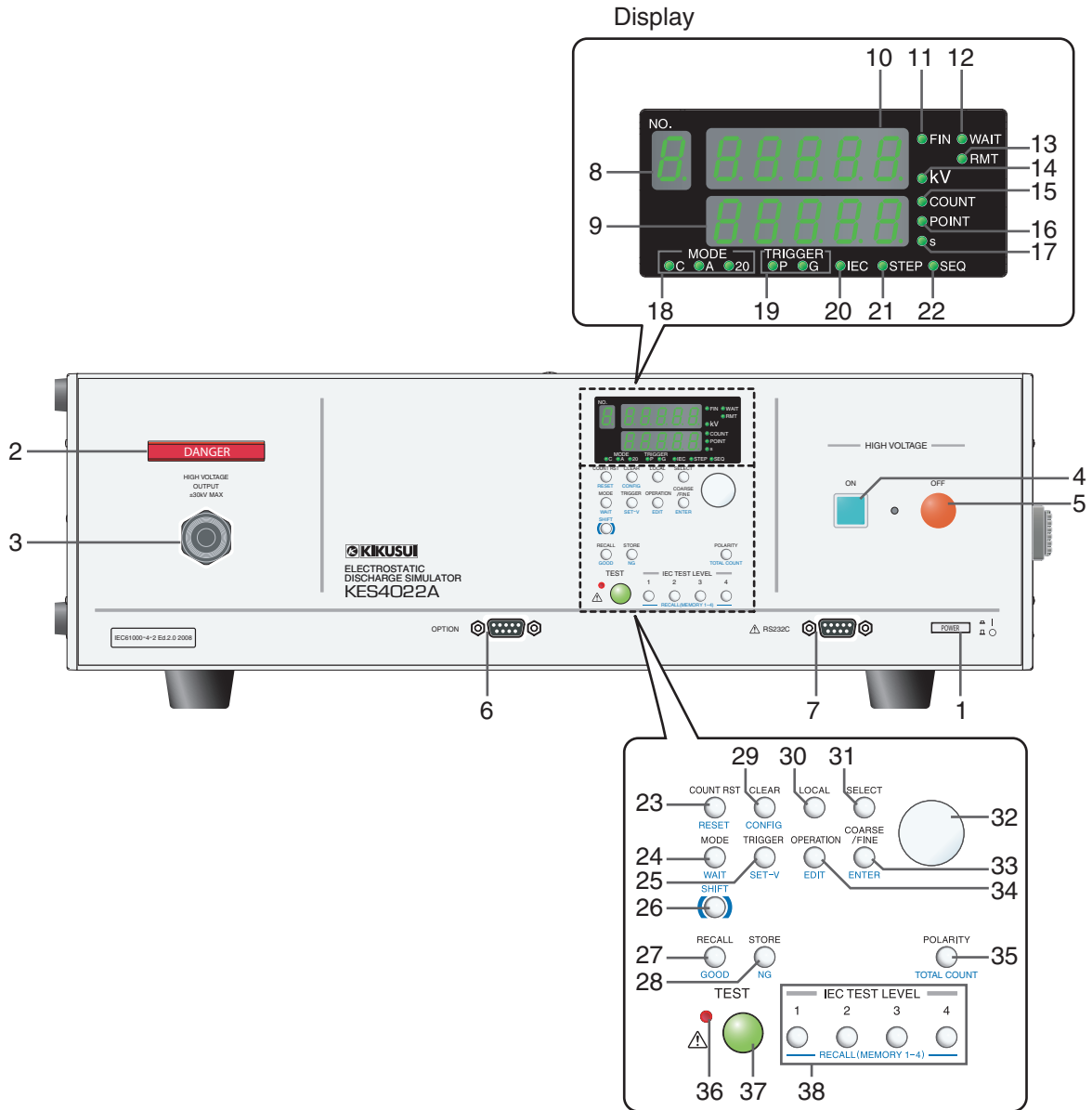

No.	Name	Function	See
1	POWER switch	Turns the power on and off.	p.25
2	DANGER indicator	Illuminates when high-voltage power is being delivered or when the KES4022A is in standby.	p.47
3	HIGH VOLTAGE OUTPUT	Delivers high voltage. The discharge gun's high-voltage cable is connected to this terminal. You cannot remove the discharge gun.	—
4	HIGH VOLTAGE ON switch	Turns high-voltage power output on.	p.47
5	HIGH VOLTAGE OFF switch	Shuts down high-voltage power output.	p.52
6	OPTION connector	Do not connect anything to this connector.	—
7	RS232C connector	RS232C interface.	p.72
8	NO. display	Displays the step number and other information.	p.72
9	Lower display	Displays the discharge points, number of discharges, discharge interval, etc.	—
10	Upper display	Displays the test voltage, etc.	—

No.	Name	Function	
11	FIN LED	Illuminates when a test finishes.	<i>p.49</i>
12	WAIT LED	Illuminates when the KES4022A is in the wait state.	<i>p.49</i>
13	RMT LED	Illuminates when the KES4022A is communicating with the PC.	<i>p.82</i>
14	KV	Illuminates when the upper display indicates the test voltage.	<i>p.30</i>
15	COUNT	Illuminates when the lower display indicates the number of discharges.	<i>p.34</i>
16	POINT	Illuminates when the lower display indicates the number of discharge points.	<i>p.36</i>
17	s	Illuminates when the lower display indicates the discharge interval.	<i>p.35</i>
18	MODE LED	The selected discharge mode illuminates: C for contact, A for air, and 20 for 20 discharges/s.	<i>p.29</i>
19	TRIGGER LED	The selected trigger illuminates: P for TEST key and G for trigger switch.	<i>p.36</i>
20	IEC LED	Illuminates when an IEC test level operation is selected.	<i>p.28</i>
21	STEP LED	Illuminates when the step operation is selected.	<i>p.28</i>
22	SEQ LED	Illuminates when the sequence operation is selected.	<i>p.28</i>
23	COUNT RST key	Resets the number of discharges.	<i>p.42</i>
	RESET key	Resets tests.	<i>p.42</i>
24	MODE key	Switches the discharge mode between contact mode, air mode, and 20 discharges/s mode.	<i>p.29</i>
	WAIT key	Configures the wait feature.	<i>p.37</i>
25	TRIGGER key	Sets the trigger to the TEST key or trigger switch.	<i>p.36</i>
	SET-V key	Sets the step operation test voltage.	<i>p.32</i>
26	SHIFT key	Activates the features indicated by blue letters below the keys	<i>p.4</i>
27	RECALL key	Recalls settings from panel memory	<i>p.41</i>
	GOOD key	No functionality.	—
28	STORE key	Saves settings to panel memory.	<i>p.40</i>
	NG key	No functionality.	—
29	CLEAR key	Resets errors.	<i>p.104</i>
	CONFIG key	For configuring the KES4022A.	<i>p.38</i>
30	LOCAL key	Switches local mode.	—
31	SELECT key	Switches the item that you will configure between the voltage, number of discharges, discharge points, or discharge interval.	—
32	Rotary knob	Changes the value.	—
33	COARSE/FINE key	Switches the resolution of the test voltage and number of discharges.	<i>p.43</i>
	ENTER key	Confirms the sequence operation settings.	—
34	OPERATION key	Selects the test method.	<i>p.28</i>
	EDIT key	For setting sequence operation steps.	—
35	POLARITY key	Switches the set voltage polarity.	<i>p.33</i>
	TOTAL COUNT key	Switches the displaying the number of times the high-voltage discharge switch has been used.	<i>p.43</i>
36	TEST LED	Illuminates during testing.	<i>p.49</i>
37	TEST key	Starts and stops testing.	<i>p.48</i>
38	IEC TEST LEVEL key	Selects the IEC61000-4-2 standard test level from 1 to 4.	<i>p.31</i>
	RECALL (MANUAL STEP) key	Recalls settings from panel memory using the direct recall feature.	<i>p.41</i>

Discharge gun

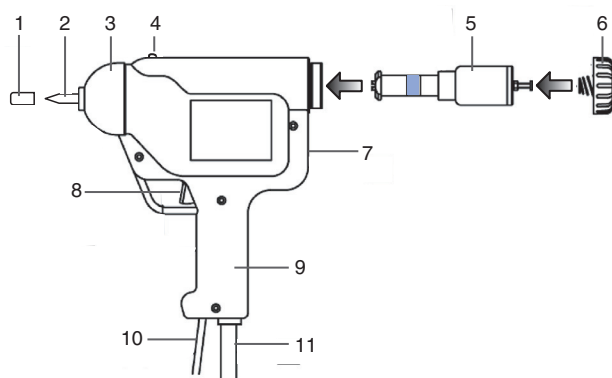

No.	Name	Function	See
1	Protective cap	Protective cap for the contact discharge tip.	p.22
2	Discharge tip	Emits electrostatic discharges to the EUT.	p.22
3	Cup	Forms the discharge current waveform.	—
4	High-voltage indicator	Illuminates when high-voltage power is being delivered or when the KES4022A is in standby.	p.47
5	CR unit	A unit that is inserted into the discharge gun.	p.21
6	CR unit cap	Holds the CR unit in place.	p.21
7	Discharge gun stand attachment	Used when the discharge gun is mounted on the optional discharge gun stand.	—
8	Trigger	For starting and stopping testing by using the discharge gun.	p.48
9	Grip	For holding the discharge gun.	—
10	Discharge return cable	Functions as a line for the discharge current to return through.	p.23
11	High-voltage cable	Composite cable that consists of a shielded high-voltage wire and signal wires.	—

Rear panel

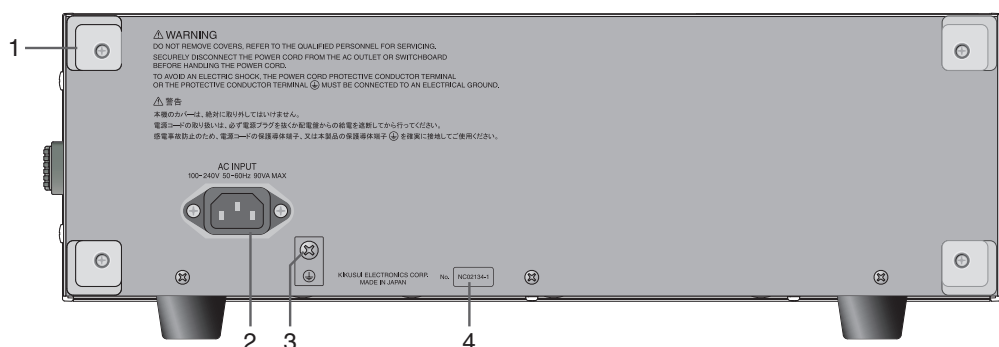

No.	Name	Function	See
1	Cord holder	For winding the power cord for storage (one in each corner).	—
2	AC INPUT connector	AC inlet.	p.24
3	Protective conductor terminal	For earth grounding the KES4022A.	p.24
4	Serial number	—	—



1

General Description

This chapter gives an overview of the KES4022A and the options that are available for it.

Product Overview

Electrostatic discharge is a commonly occurring phenomenon. An arc current or electromagnetic wave caused by electrostatic discharge entering an electronic circuit can cause errors and failures. This is a serious problem today, because the vast majority of electric and electronic devices use semiconductors. Standards that define electrostatic discharge immunity and that specify methods for testing immunity have been established to deal with this problem.

The KES4022A Electrostatic Discharge Simulator is used to perform immunity testing on electric and electronic devices subject to electrostatic discharges. It can perform testing that conforms to the IEC61000-4-2 standard.

Features

- **Testing based on the IEC 61000-4-2 standard**

The KES4022A complies with IEC 61000-4-2 Ed.2.0 2008-12.

IEC/ISO-compliant model conform to the ISO 10605 Ed. 2.0 2008-07 standard for the electrostatic discharge testing of automotive electronics.

- **Maximum test voltage: ± 30 kV**

The maximum test voltage is ± 30 kV. This allows you to perform preliminary tests and allowance tests.

The KES4022A can perform contact discharge and air discharge testing.

- **Easy operation**

The panel is designed for easy operation. You can select test levels from the panel.

- **Memory features**

Twenty sets of test conditions can be stored separately for manual, IEC test level, step, and sequence modes.

- **Step operation**

You can set step voltages and perform testing by changing the test voltage by small amounts.

- **Sequence operation**

You can perform testing by combining various test conditions. You can easily configure the test conditions from a PC through the RS232C interface.

- **Multi-point discharges**

Because you can set multiple discharge points (up to 10 points), you can save time in testing.

- **Configuration of test conditions using a PC**

You can use the application software (that is stored in KES4022A_SAMPLE_APPLICATION_SOFTWARE.xls) to set test conditions and transmit test conditions to the KES4022A through RS232C. You can also edit the test conditions set from the panel.

For information about options, contact your Kikusui agent or distributor.

CR units and discharge tips for ISO10605:2001



We offer discharge tips and CR units. A CR unit consist of an energy storage capacitor and a discharge resistor.

CR units

Calibration is necessary if you want to change the CR unit that is included as standard, and perform testing based on standards such as IEC 61000-4-2 and ISO 10605. To have your KES4022A calibrated, contact your Kikusui distributor or agent.

CR32-KES	330 pF/330 Ω	
CR33-KES	150 pF/2 kΩ	
CR34-KES	330 pF/2 kΩ	

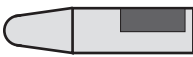
Discharge tips

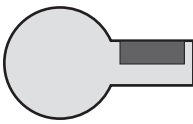
AT32-KES	Air discharge tip (2 kΩ)	
CT32-KES	Contact discharge tip (2 kΩ)	
ST31-KES	Sphere discharge tip (330 Ω)	
ST32-KES	Sphere discharge tip (2 kΩ)	

C units and discharge resistors

IEC61000-4-2 specifies the combination of a 150-pF energy storage capacitor and a 330-Ω discharge resistor. These options are used to test other combinations.

C unit	Discharge resistor	
EC21-KES: 150 pF	DR21-KES: 330 Ω	DR28-KES: 1 kΩ
EC22-KES: 100 pF	DR22-KES: 100 Ω	DR29-KES: 1.5 kΩ
EC23-KES: 200 pF	DR23-KES: 150 Ω	DR30-KES: 2 kΩ
EC24-KES: 250 pF	DR24-KES: 200 Ω	DR31-KES: 5 kΩ
EC25-KES: 300 pF	DR25-KES: 300 Ω	DR32-KES: 10 kΩ
EC26-KES: 330 pF	DR26-KES: 400 Ω	DR33-KES: 10 Ω
EC27-KES: 400 pF	DR27-KES: 500 Ω	—
EC28-KES: 500 pF		

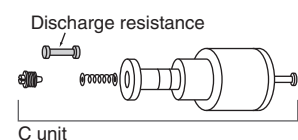

Electrostatic discharge immunity testing environment

IEC61000-4-2 defines electrostatic discharge immunity testing apparatus based on the characteristics of the EUT. These options can be combined to create an apparatus for performing electrostatic discharge immunity testing that is appropriate for the EUT.

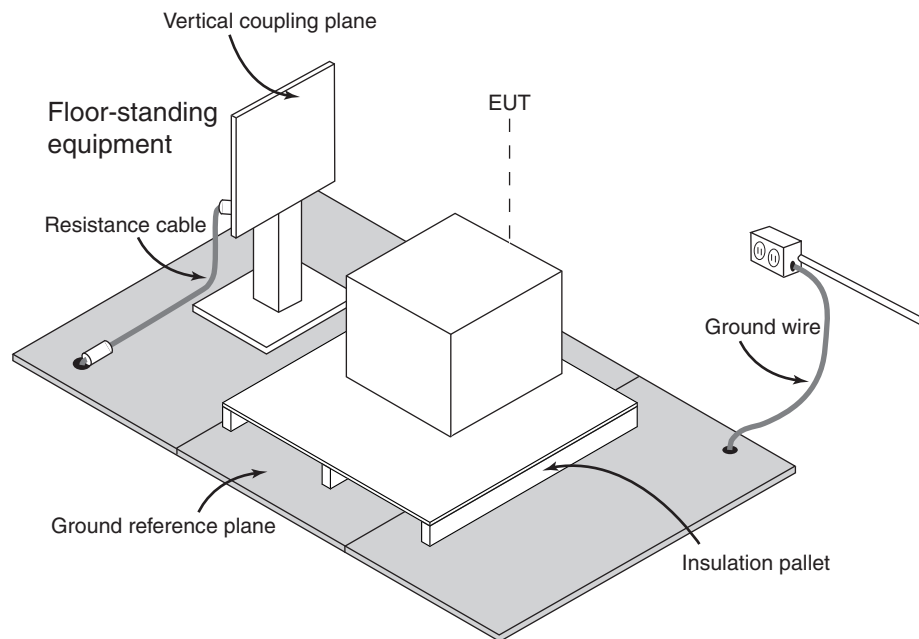
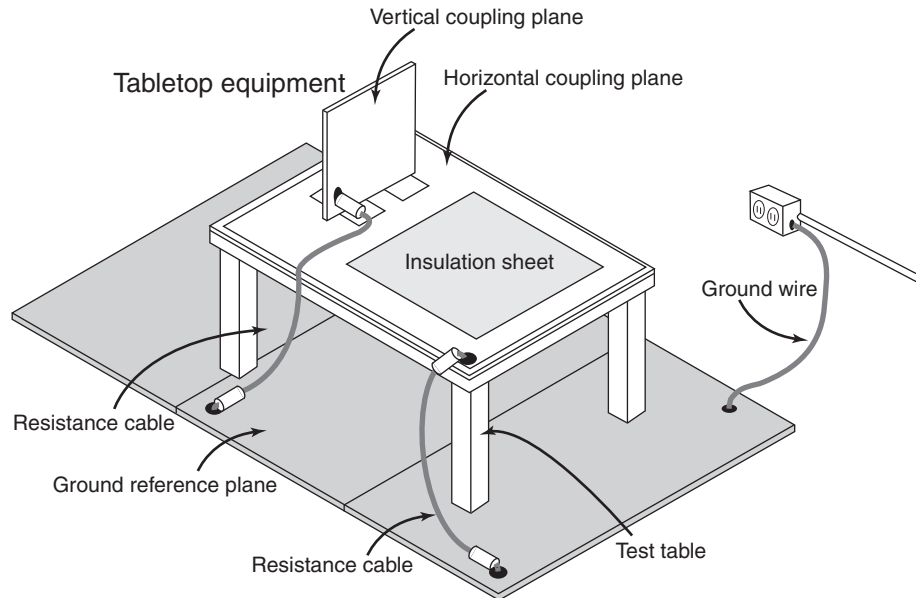

Ground reference plate (GP21-KES)

Three aluminum plates are joined together to create the ground reference plane whose dimensions are 1800 mm × 2700 mm × 1.6 mm. The size of each aluminum plate is 1800 mm × 900 mm.

Horizontal coupling plane (ZC21-KES)

The horizontal coupling plane measures 1600 mm × 800 mm and is a metal plate with the same thickness and material as the ground reference plane.

Vertical coupling plane (VC21-KES or VC22-KES)

The vertical coupling plane is used to perform indirect discharge testing. The vertical coupling plane measures 500 mm × 500 mm and is a metal plate with the same thickness and material as the ground reference plane.

VC21-KES	Tabletop type
VC22-KES	Floor-standing type

Resistance cable (CL21-KES)

This cable is used to connect the horizontal or vertical coupling plane to the ground reference plane. A 470-kΩ resistor is attached to each end.

Insulation sheet (IS21-KES)

This 0.5-mm-thick sheet is used to electrically isolate the horizontal coupling plane from the EUT.

Testing table (TT21-KES)

This table is used to test EUTs that are designed to be used on a tabletop. It is a wooden table that is 800 mm in height whose tabletop measures 1600 mm × 800 mm.

Insulation pallet (IP21-KES)

This 10-cm-thick pallet is placed on the ground reference plane to insulate the EUT from the ground reference plane.

Discharge gun stand (GS21-KES)

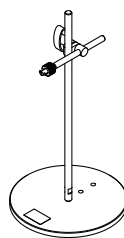

This stand is used to hold the discharge gun.

Dimensions: 402 mm × 200 φ mm

Weight: Approx. 3 kg.





2

Installation and Preparation

This chapter describes how to unpack and prepare this product before you use it.

Checking the Package Contents

When you receive the product, check that all accessories are included and that the accessories have not been damaged during transportation.

If any of the accessories are damaged or missing, contact your Kikusui agent or distributor.

We recommend that you keep all packing materials, in case the product needs to be transported at a later date.

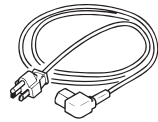

or

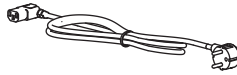

or

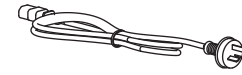

Rated voltage: 125 Vac
PLUG: NEMA5-15
[85-AA-0003]

Rated voltage: 250 Vac
PLUG: CEE7/7
[85-AA-0005]

Rated voltage: 250 Vac
PLUG: GB1002
[85-10-0790]

Power cord (1 pc.)

The power cord that is provided varies depending on the destination for the product at the factory-shipment.

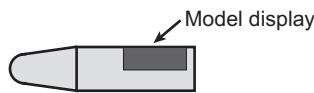

Air discharge tip (330 Ω)
[AT31-KES]

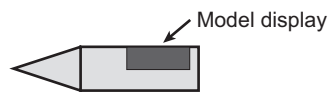

Contact discharge tip (330 Ω)
(with a protective cap)
[CT31-KES]

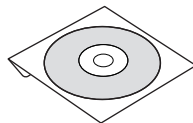

CD-ROM (1 pc.)
[SA-6034]

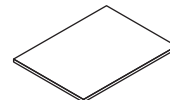

Operation manual (1 copy)
[Z1-004-702]

IEC/ISO-compliant model only

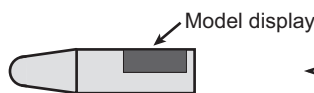

Air discharge tip (2 kΩ)
[AT32-KES]

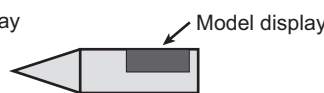

Contact discharge tip
(with a protective cap)
[CT32-KES]

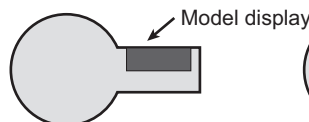

Sphere discharge tip
(330 Ω) [ST31-KES]

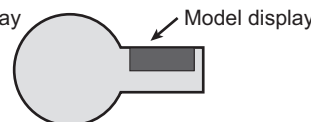

Sphere discharge tip
(2 kΩ) [ST32-KES]

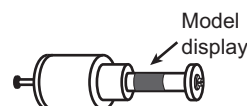

CR unit
(330 pF/330 Ω)
[CR32-KES]

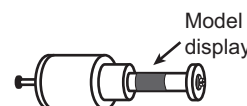

CR unit
(150 pF/2 kΩ)
[CR33-KES]

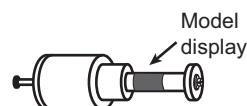

CR unit
(330 pF/2 kΩ)
[CR34-KES]

The CR31-KES unit (that consists of a 150-pF energy storage capacitor and a 330-Ω discharge resistor) is built into the discharge gun.

Precautions about the Installation Location

You must observe the following precautions when installing the product.

- **Do not use the product in a flammable atmosphere.**

To prevent the possibility of explosion or fire, do not use the product near alcohol, thinner, or other combustible materials, or in an atmosphere containing such vapors.

- **Avoid locations where the product is exposed to high temperature or direct sunlight.**

Do not install the product near a heater or in areas subject to drastic temperature changes.

Operating temperature range:	+10 °C to +40 °C (+50 °F to +104 °F)
Storage temperature range:	-5 °C to +70 °C (+23 °F to +158 °F)

- **Avoid humid environments.**

Do not install the product in high-humidity locations such as near a boiler, humidifier, or water supply.

Operating humidity range:	10 %rh to 80 %rh (no condensation)
Storage humidity range:	10 %rh to 80 %rh (no condensation)

Condensation may form even within the operating humidity range. If this happens, do not use the product until the condensation dries up completely.

- **Use the product indoors at up to 1300 m above sea level.**

This product is designed for safe indoor use. The operating altitude limit is 1300 m above sea level.

- **Provide adequate space around the power cord plug.**

Do not insert the power cord plug into an outlet that is not easily accessible. Do not place objects near the power cord plug that would make it difficult to access.

- **Do not install the product in a corrosive atmosphere.**

Do not install the product in a corrosive atmosphere or in environments containing sulfuric acid mist, etc. This may cause corrosion of various conductors or reduce the quality of the connector contacts inside the product, and this could lead to malfunction, failure, and possibly fire.

- **Do not install the product in a dusty location.**

Dust accumulation can lead to electric shock or fire.

- **Do not use the product in a poorly ventilated location.**

Provide adequate space around the product for air to circulate around it.

- **Do not place objects on top of the product.**

Placing heavy objects on top of the product may cause malfunction.

- **Do not install the product on an inclined surface or in a location subject to vibrations.**

The product may fall or tip over and cause damage and injury.

- **Do not use the product in a location subject to strong magnetic or electric fields or in a location where the input power supply signal contains large amounts of distortion or noise.**

Doing so may cause the product to malfunction.

- **Do not use the product near medical, electronic, or communication devices other than the EUT.**

This product emits strong electromagnetic noise. We recommend that you use the product in a shielded room. Keep it sufficiently away from medical, electrical, electronic, and communication devices that may be adversely affected by electromagnetic noise.

- **Do not place objects near the product that will injure the operator if the operator bumps into them.**

If the operator receives an electric shock by mistake, the operator may react by abruptly pulling his or her hand or by jumping back. In addition to direct injuries caused by electric shock, the operator may suffer secondary injuries from bumping into objects or from falling over when the operator reacts to the shock. Perform testing in a place with sufficient space.

- **Do not perform testing if a dangerous condition would result when the EUT power supply shorts.**

The power supply may short-circuit if the EUT breaks. Take measures so that a dangerous condition will not result even if a short circuit occurs. We recommend that you use an isolation transformer with the AC power supply used for testing to separate it from other power supply systems.

- **Be sure to adhere to the testing environment that the standard specifies.**

The standard specifies various test conditions such as the size of the ground reference plane, the distance from walls, the use of the horizontal coupling plane, and the use of the vertical coupling plane. For details on the testing environment, see the respective standard.

Precautions for Moving the Product

When moving or transporting the product to the installation location, be sure to:

- **Turn the POWER switch off.**

Moving the product with the POWER switch turned on may cause electric shock or damage to the product.

- **Disconnect all wiring and the discharge tip.**

Moving the product with the cables connected may cause wires to break or injuries due to the product falling over.

- **Hold the product with both hands while making sure that the discharge gun does not fall.**

You cannot remove the discharge gun from the main unit.

- **Use the original packing materials (when transporting the product).**

Otherwise, damage may result from vibrations or from the product falling during transportation.

- **Include this manual.**

Preparing the Discharge Gun



To avoid electric shock, wait at least 1 minute after turning the POWER switch off before checking the CR unit, removing the discharge tip, and connecting the discharge return cable.

See p. 99

Do not drop the discharge gun. If you drop it, do not use it.

To maintain good insulation characteristics, be sure to clean the red discharge gun cup before testing.

CR units and discharge tips can distinguish discharge resistor value with the color of the model display label.

330 Ω discharge resistors: Purple

2 k Ω discharge resistors: Green

Checking and replacing the CR unit

The CR unit consists of an energy storage capacitor that generates electrostatic discharge and a discharge resistor that limits the discharge current.



To avoid electric shock, turn the POWER switch off before checking or replacing the CR unit. A buzzer will sound if you remove the CR unit cap while the POWER switch is on.



Do not remove the CR unit's internal discharge resistor. If you do so, the generated waveform is no longer guaranteed.

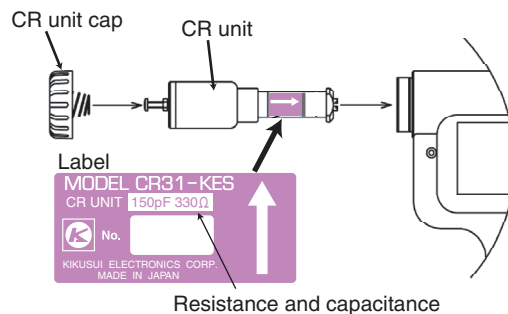

- 1 Check that the POWER switch is off.**
If it is on, turn it off, and wait at least 1 minute. The KES4022A will naturally discharge down to a safe voltage.
- 2 Remove the CR unit cap, and remove the CR unit from the discharge gun.**
- 3 Check the capacitor and discharge resistor values (150 pF and 330 Ω for a standard setting).**
- 4 Put the CR unit back into the discharge gun.**
- 5 Securely attach the CR unit cap.**

Attaching the discharge tip

Discharge tips are metallic electrodes for applying electrostatic discharges to the EUT. There are three types of discharge tips: contact discharge tip, air discharge tip, and sphere discharge tip. Attach the appropriate tip according to the test objective.

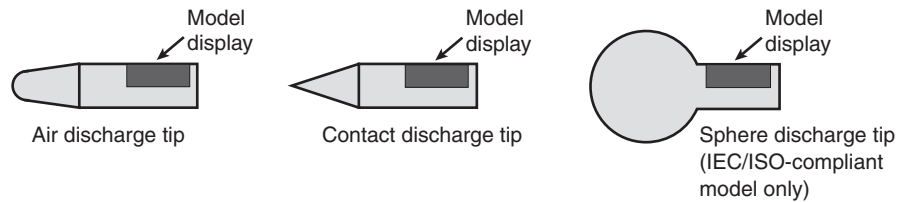

The contact discharge tip is sharp. Put the protective cap on it when it is not in use. The protective cap is made of vinyl. If you apply strong force to the cap when it is on the tip, the tip may pierce through the cap.

CAUTION

Dropping the discharge tip or applying strong shock to it may break the tip or cause waveforms to be distorted.

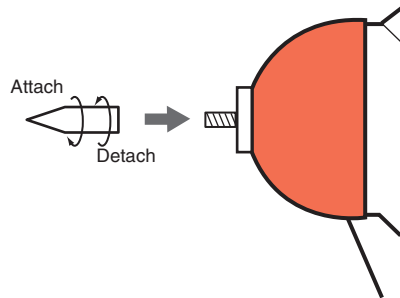

- 1 Check that the POWER switch is off.**
If it is on, turn it off, and wait at least 1 minute. The KES4022A will naturally discharge down to a safe voltage.
- 2 Securely attach the discharge tip to the discharge gun.**

Connecting the discharge return cable

The discharge return cable is a line for the discharge current to return through. Do not use it in a wound or bundled condition.



To avoid electric shock, securely connect the discharge return cable to the ground reference plane.

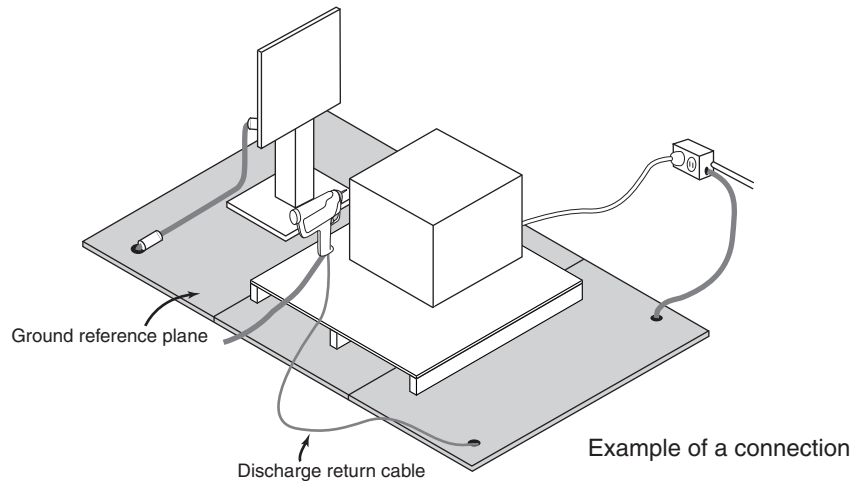

- 1 Check that the POWER switch is off.**
If it is on, turn it off, and wait at least 1 minute. The KES4022A will naturally discharge down to a safe voltage.
- 2 Securely connect the discharge return cable to the ground reference plane.**

Preliminary inspection

Be sure to perform a preliminary inspection to prevent electric shock and to maintain the KES4022A's long-term performance.

- 1 Check that the insulation of the high-voltage cable and discharge return cable is clean and not broken.**
- 2 Check that the cable insulation at the HIGH VOLTAGE OUTPUT terminal and at the root of the discharge gun is not misaligned or loose.**
- 3 Check that the discharge gun does not have cracks and that the screws are fastened securely.**
- 4 Check that the CR unit cap is securely fastened.**
- 5 Check that the red discharge gun cup is not dirty.**
To maintain good insulation characteristics, clean the cup if it is dirty.

See p. 99

Connecting the Power Cord

This product falls under IEC Overvoltage Category II (energy-consuming equipment supplied from the fixed installation).



WARNING To avoid electric shock, observe the following precautions.

- This product is IEC Safety Class I equipment (equipment with a protective conductor terminal). Be sure to earth ground the product to prevent electric shock.
- Connect the protective conductor terminal to earth ground.



- Use the supplied power cord to connect to an AC power line. If the supplied power cord cannot be used because the rated voltage or the plug shape is incompatible, have a qualified engineer replace it with an appropriate power cord that is 3 m or less in length. If obtaining an appropriate power cord is difficult, consult your Kikusui agent or distributor.
- A power cord with a plug can be used to disconnect the product from the AC line in an emergency. Connect the plug to an easily accessible power outlet so that the plug can be removed from the outlet at any time. Be sure to provide adequate clearance around the power outlet.
- Do not use the supplied power cord for other devices.

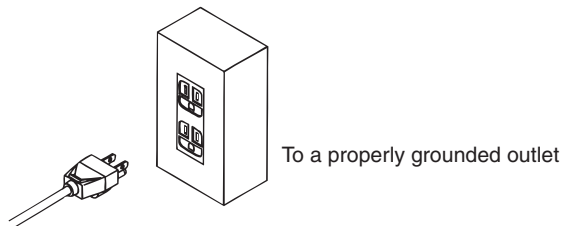

- 1** Check that the **POWER** switch is off.
- 2** Check whether or not the **AC power line is compatible with the input rating of the product.**
The product can receive a nominal line voltage in the range of 100 Vac to 240 Vac at 50 Hz or 60 Hz.
- 3** Connect the power cord to the rear-panel **AC INPUT.**
- 4** Connect the power cord plug to an outlet with a ground terminal.

You can also ground the KES4022A through the protective conductor terminal. Have a qualified engineer construct a proper cable and connect it. Use appropriate tools and securely connect the cable.

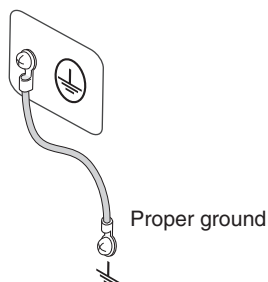

Turning the power on

Turning the POWER switch on

2

Installation and Preparation

See p. 23

- 1 Perform preliminary inspection on the discharge gun.**
- 2 Check that the power cord is connected properly.**
- 3 Press the front-panel POWER switch so that it is on (the I position).**
If you notice strange sounds, unusual odors, fire, or smoke around or from inside the KES4022A, remove the power cord plug from the outlet.
- 4 Check the firmware version on the screen.**
After all LEDs on the front panel illuminate, the upper display shows the model name, and the lower display shows the firmware version for several seconds.



Example of firmware version 1.00

When you turn the POWER switch on for the first time after purchase, the KES4022A starts with its factory default settings.

See p. 38

You can use CONFIG setting 7 (the panel settings at power-on) to specify the panel settings that will be in effect when the POWER switch is turned on.

Turning the POWER switch off

⚠ CAUTION

To avoid breakdown, allow at least 10 seconds to turn the KES4022A's POWER switch on after it has been turned off, or off after it has been turned on. Do not needlessly turn the switch on and off repeatedly.

- 1 Check that the DANGER indicator is not illuminated.**
If it is, press the HIGH VOLTAGE OFF switch to stop the output.
- 2 Connect the discharge tip to GND to discharge the remaining electric charge.**
- 3 Press the front-panel POWER switch so that it is off (the O position).**
- 4 Clean the test area so that it is free of obstacles.**

Except for in an emergency, do not turn the POWER switch off while the output is on. The KES4022A protective features may not activate. If you turn the POWER switch off while the output is on in an emergency, be sure to eliminate the dangerous condition, and do not use the KES4022A until safety has been assured.

Steps to Be Taken in an Emergency

If an emergency situation such as electric shock or EUT breakdown occurs due to problems with the KES4022A or the EUT, turn the POWER switch off immediately, and remove the power cord plug from the outlet. The KES4022A high-voltage power supply will be shut down, and discharging will stop.

Record the KES4022A conditions, and contact your Kikusui agent or distributor.

■ Emergency and abnormal situations

- Electric shock
- EUT breakdown
- Operation errors in devices other than the EUT
- Constant ringing of the KES4022A buzzer
- Abnormal set voltage
- Abnormal sounds inside the discharge gun or the main unit

■ Turning the power on after an emergency situation occurred in a device other than this KES4022A

- 1** Eliminate the dangerous condition.
- 2** Make sure that everything is safe.
- 3** Turn the POWER switch on.

3

Panel Operation Basics

This chapter describes how to set basic items.



WARNING

To avoid electric shock, observe the following precautions.

- By design, the KES4022A has exposed parts that generate high voltages that are greater than or equal to 30 kV. When the KES4022A is generating high voltage, do not bring your hands close to such parts.
- During or after testing, the EUT and metal parts within the testing environment may also be charged with high voltage. Do not touch anything other than the ground reference plane during testing. Metal parts that are not electrically connected to the reference plane remain charged even after testing has been completed. Do not touch the parts until you discharge the electrical charge.
- Discharge only to the EUT, vertical coupling plane, horizontal coupling plane, or ground reference plane.
- If you notice anything abnormal about the KES4022A, turn the POWER switch off, and remove the power cord plug from the outlet. After correcting the problem, check carefully to make sure that everything is safe, and then turn the power on.

Selecting the Discharge Test

There are two types of discharge test modes: manual and auto. There is one manual operation. There are three auto operations: IEC test level, step, and sequence. Each time you press OPERATION, the selected operation switches.

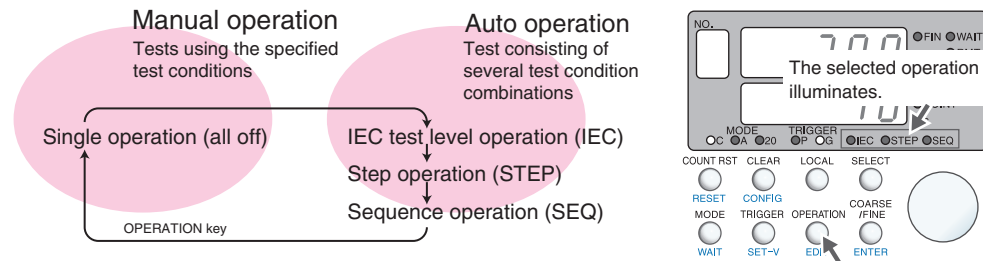

Manual operation (single operation) (IEC STEP SEQ)

When testing is performed, the test conditions remain the same unless you change them. If the IEC LED, STEP LED, and SEQ LED are all off, single operation is selected.

You can also select the IEC61000-4-2 test level.

Auto operation

An auto operation test uses several sets of test conditions. Each set of test conditions is tested in order.

■ IEC test level operation (IEC STEP SEQ)

Auto operation in which you set the IEC test levels and polarities.

Testing is performed in order from the lowest IEC61000-4-2 test level to the selected test level. The IEC LED illuminates.

■ Step operation (IEC STEP SEQ)

Auto operation in which you set the step voltage and polarities.

Testing is performed in order according to the set starting, ending, and step voltages. The STEP LED illuminates.

If you select step operation, the upper display shows “— — — —”.

■ Sequence operation (IEC STEP SEQ)

Auto operation in which you set appropriate test conditions.

Testing is performed in order from step 1 using to the set test conditions. The SEQ LED illuminates.

NOTE

You set sequence operation test conditions after switching to the sequence editing screen by pressing EDIT (SHIFT+OPERATION). For details, see the “Performing Sequence Testing” in chapter 5.

Selecting the Discharge Mode

The IEC61000-4-2 standard defines Contact Discharge and Air Discharge. For more details, see the IEC61000-4-2 standard.

■ Contact Discharge mode

Contact discharge can be divided into direct discharge and indirect discharge.

In direct discharge, you touch the EUT with the discharge tip.

In indirect discharge, you discharge to the vertical or horizontal coupling plane that is installed near the EUT.

■ Air Discharge mode

In air discharge, you hold the discharge gun grip and bring the air discharge tip closer to the EUT. Air discharge takes place in this process.

Selecting the discharge mode

Select which discharge mode you will use for testing.

In addition to the Contact Discharge and Air Discharge modes, the KES4022A has a 20 discharges/s Contact Discharge mode (with a discharge interval of 0.05 s) that is useful in preliminary testing.

The discharge mode switches in order each time you press MODE. The LED corresponding to the selected discharge mode illuminates.

- C: Contact Discharge
- A: Air Discharge
- 20: 20 discharges/s Contact Discharge

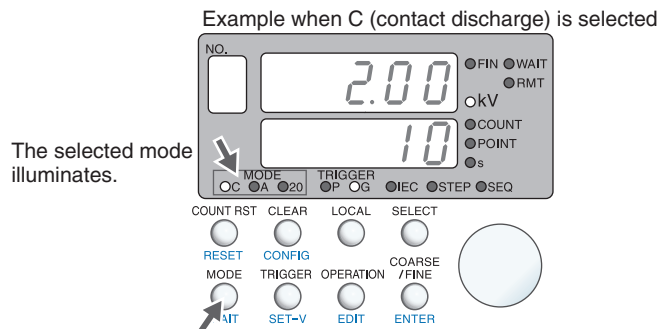

If the EUT has insulation coating on it, perform air discharge testing.

Setting Test Voltages

Setting the voltage (in manual or sequence operation)

Carry out the procedure below to set the test voltage.

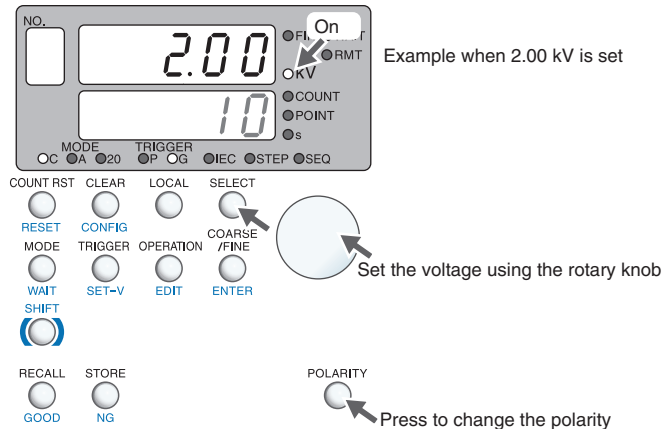

- 1 Press SELECT key to turn the kV LED on.**
Press SELECT key repeatedly until the kV LED turns on.
- 2 Turn the rotary knob to set the test voltage (in the range of 0.00 kV to 30.50 kV in manual operation or 0.01 kV to 30.50 kV in sequence operation).**
- 3 To change the test voltage polarity, press POLARITY key.**
The polarity switches each time you press POLARITY.

See p. 33

Setting the IEC61000-4-2 test level (in manual or IEC test level operation)

Press IEC TEST LEVEL1, 2, 3, or 4 to set the IEC61000-4-2 test level voltage. The selected key illuminates.

The test voltage varies depending on the discharge mode.

Example when IEC test level 2 is selected

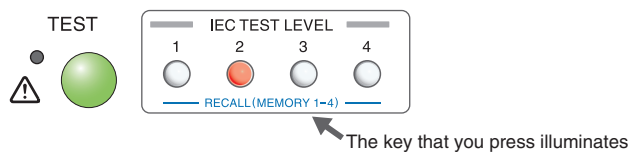
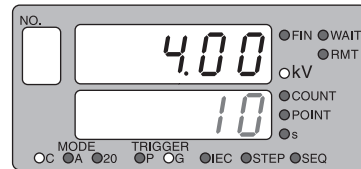

Test level	C or 20: Contact Discharge mode	A: Air Discharge mode
LEVEL 1	2.0 kV	2.0 kV
LEVEL 2	4.0 kV	4.0 kV
LEVEL 3	6.0 kV	8.0 kV
LEVEL 4	8.0 kV	15.0 kV

Manual operation

Testing is performed only at the selected test level. If you change the test voltage, the key turns off. The test voltage polarity switches each time you press POLARITY key.

IEC test level operation

Testing is performed in order from the lowest level to the selected level.

Set the test voltage polarity using the POLARITY key after setting the voltage.

See p. 33

Setting step operation test voltages

You can set the step operation start, stop, and step voltages. To test using decreasing steps, set the stop voltage lower than the start voltage.

See p. 33

Set the test voltage polarity using the POLARITY key after setting the voltage.

Setting step operation voltages

If a step voltage exceeds the stop voltage, the stop voltage is used. For example, if you set the start voltage to 0.5 kV, the stop voltage to 1 kV, and the step voltage to 0.45 kV, the KES4022A tests 0.5 kV and 0.95 kV. The next voltage would be 1.4 kV, but the KES4022A tests the stop voltage of 1 kV and stops the test.

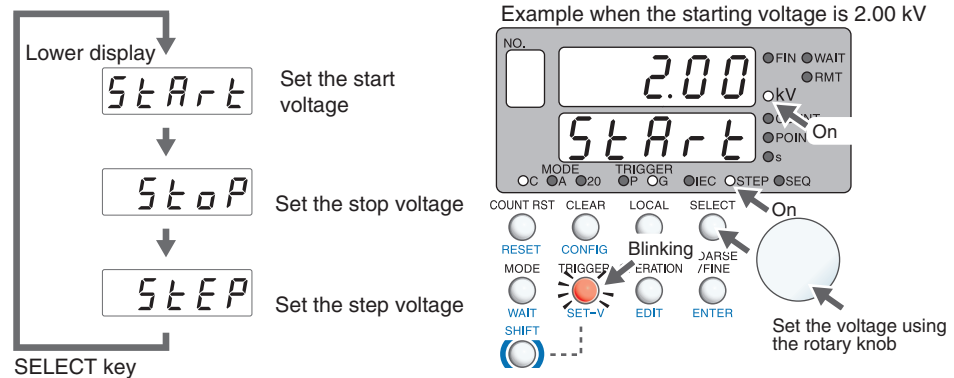

You can press IEC TEST LEVEL 1, 2, 3, or 4 to set an IEC61000-4-2 test level voltage. When you set the start or end voltage, the selected key illuminates. If you change the test voltage, the key turns off.

- 1 Check that the STEP LED is turned on.**
If it is not, press OPERATION key to turn the STEP LED on so that step operation is selected. If you do not select step operation, you cannot set the step operation voltages.
- 2 Press SET-V (SHIFT+TRIGGER) key to switch to the start voltage setup screen.**
The lower display shows "StArt."
- 3 Turn the rotary knob to set the start voltage in the range of 0.01 kV to 30.50 kV.**
- 4 Press SELECT key to switch to the stop voltage setup screen.**
The lower display shows "StoP."
- 5 Turn the rotary knob to set the stop voltage in the range of 0.01 kV to 30.50 kV.**
To test using decreasing steps, set the stop voltage lower than the start voltage.
- 6 Press SELECT key to switch to the step voltage setup screen.**
The lower display shows "SteP."
- 7 Turn the rotary knob to set the step voltage in the range of 0.01 kV to 30.50 kV.**
- 8 Press SET-V (SHIFT+TRIGGER) key to close the step operation voltage setup screen.**
The upper display shows "- - - -", and the settings are confirmed.

Setting the Polarity

Press POLARITY key to select the output voltage polarity.

Manual operation or sequence operation

The output voltage polarity switches each time you press POLARITY key. When negative is selected, a minus sign appears at the left of the upper display.

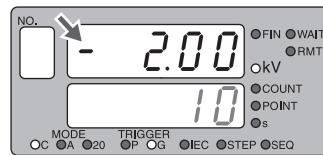

Example when -2.00 kV is set



POLARITY The polarity changes each time you press this key

IEC test level operation or step operation

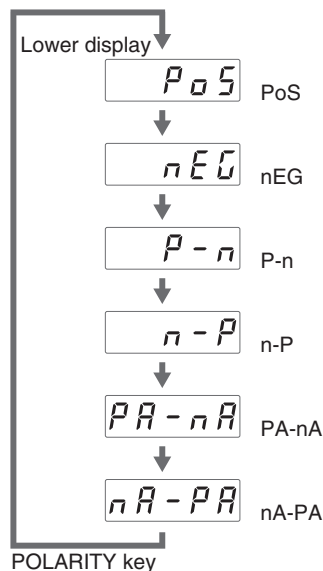

Example when Pos is selected

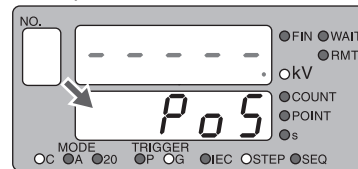

POLARITY The polarity changes each time you press this key

In the IEC test level and step operations, you can configure the KES4022A to switch the polarity for each step, to test all steps using positive voltages and then all steps using negative voltages, or to test all steps using negative voltages and then all steps using positive voltages. Each time you press POLARITY key, the setting changes in order as shown below. The lower display shows the selected setting.

PoS		Test only positive voltages
nEG		Test only negative voltages
P-n		Start with a positive voltage and switch the polarity for each step
n-P		Start with a negative voltage and switch the polarity for each step
PA-nA		Test all steps using positive voltages and then all steps using negative voltages
nA-PA		Test all steps using negative voltages and then all steps using positive voltages

A minus sign appears at the left of the upper display when nEG is selected during an IEC test level operation or when you are setting test conditions for step operation. When you have selected P-n, n-P, PA-nA, or nA-PA, a minus sign blinks at the left of the upper display. A plus sign does not appear when PoS is selected.

The following figure illustrates how the polarity changes for different settings in an IEC test level operation.

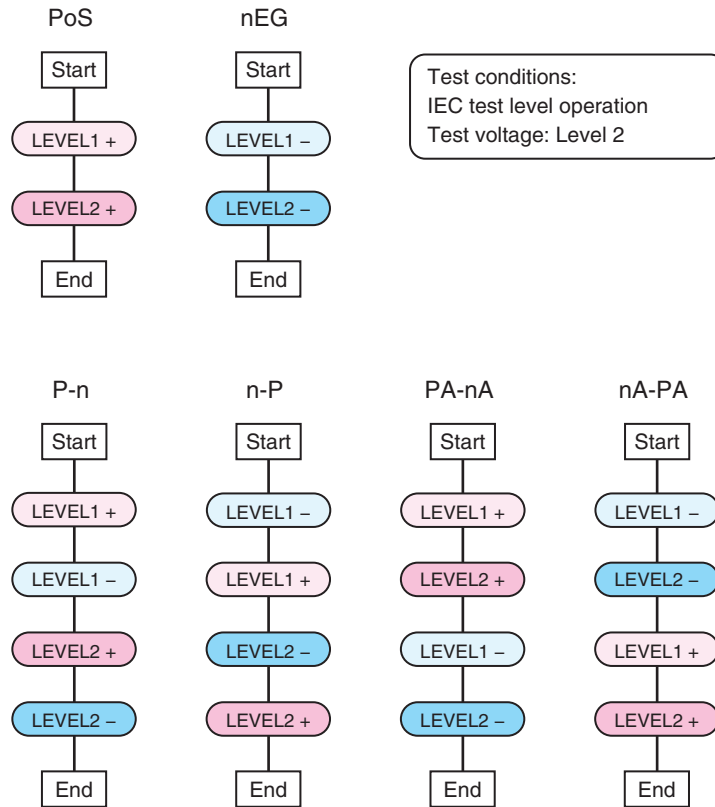

Setting the Number of Discharges

Set how many times the KES4022A will discharge at each discharge point or step.

Electrostatic discharge immunity testing places electrical stress on the EUT. Set an appropriate number of discharges.

In the IEC61000-4-2 standard, the minimum number of discharges for each point is 10.

In manual operation, you can specify infinity. If you specify infinite testing, testing continues until you pause it or until you press HIGH VOLTAGE OFF switch.

Example when the number of discharges is set to 10

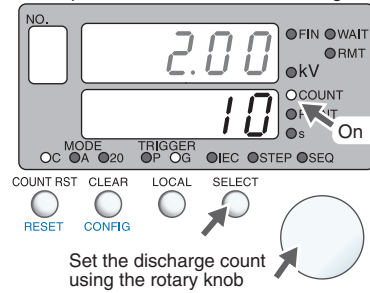

- 1 Check that the DANGER indicator is off.**
If not, press HIGH VOLTAGE OFF switch.
- 2 Press SELECT to turn the COUNT LED on.**
Press SELECT key repeatedly until the COUNT LED turns on.
- 3 Turn the rotary knob to set the number of discharges to a value from 1 to 99999 or to “-----.”**
“-----” corresponds to infinite (available only in manual operation). To select “-----,” turn the rotary knob fully counterclockwise.
Press COARSE/FINE key to change the resolution.

See p. 43

Setting the Discharge Interval

Set the discharge interval.

The discharge interval is 1 second in the IEC61000-4-2 standard.

Example when the discharge interval is set to 1.0 s

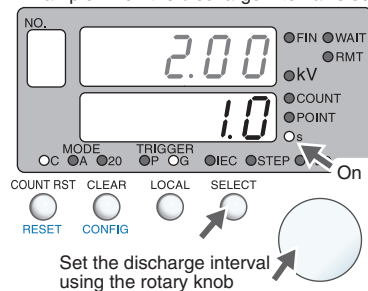

- 1 Check that the DANGER indicator is off.**
If not, press HIGH VOLTAGE OFF switch.
- 2 Press SELECT key to turn the s LED on.**
Press SELECT key repeatedly until the s LED turns on.
- 3 Turn the rotary knob to set the discharge interval in the range of 0.1 s to 99.9 s.**

Setting the Discharge Points

Set how many times to repeat the discharges using the same test conditions. This option is valid when auto operation is selected.

This option is useful for discharging to multiple locations.

When you specify multiple discharge points, we recommend that you perform testing with the wait feature turned on.

See p. 37

Example when the number of discharge points is 3

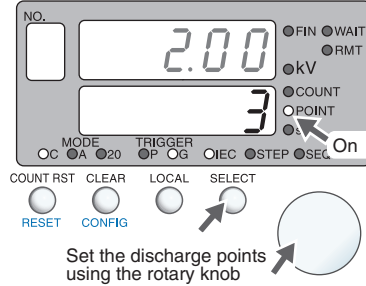

- 1 Check that the DANGER indicator is off.**
If not, press HIGH VOLTAGE OFF switch.
- 2 Press SELECT key to turn the POINT LED on.**
Press SELECT key repeatedly until the POINT LED turns on.
- 3 Turn the rotary knob to set the discharge points in the range of 1 to 10.**

Setting the Trigger Used to Start Testing

Select whether to start testing by using the discharge gun trigger or by using the front-panel TEST key. The front-panel TEST key is used when the discharge gun is mounted on the optional discharge gun stand.

The trigger mode switches each time you press TRIGGER key. The selected trigger LED illuminates.

- P (PANEL): Start the test by using the front-panel TEST key.
- G (GUN): Start the test by using the discharge gun trigger.

Example when the trigger is set to discharge gun

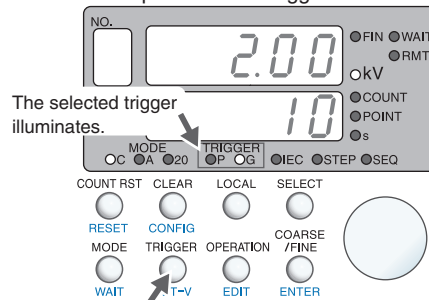

See p. 38

If you set the trigger mode to GUN, you can set how the gun trigger will operate.

Configuring the Wait Feature

If you enable the wait feature, the KES4022A pauses testing at each discharge point and step. Before the next point or step is tested, another trigger is required. If the wait feature is off, the testing of the next point or step starts after approximately 3 seconds.

This option is valid when auto operation is selected. It is invalid when air discharge mode is selected.

The wait feature is useful when you want to check the EUT condition at each discharge point or step or when multiple discharge points are specified.

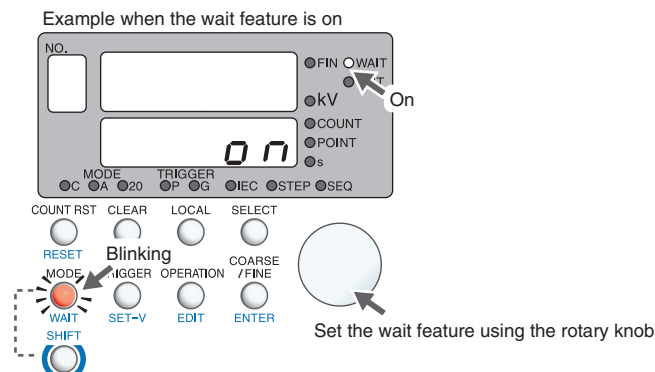

- 1 Press WAIT (SHIFT+MODE) key.**
The WAIT LED turns on, and the WAIT (SHIFT+MODE) key blinks.
- 2 Turn the rotary knob to enable or disable the wait feature.**
Turn the knob to the right to enable (on) the feature or to the left to disable (off) it.
- 3 Press WAIT (SHIFT+MODE) key again.**
The wait feature is enabled.

Specifying the CONFIG Settings

This section explains how to set the KES4022A operating conditions.

SELECT key

1. Set the RS232C baud rate
2. Buzzer volume (when a test ends)
3. Buzzer volume (when an alarm occurs)
4. Display brightness
5. Discharge counter mode
6. Discharge gun trigger mode
7. Power-on panel settings
8. Memory protect

Example when the discharge gun trigger mode is Push

1 To set the discharge counter mode or gun trigger mode, select the appropriate testing mode (manual, IEC test level, step, or sequence).

Set the discharge counter mode and gun trigger mode separately for each testing mode. Select the testing mode that you want to set first.

2 Press CONFIG (SHIFT+CLEAR) key.

The CONFIG screen appears, and the CONFIG (SHIFT+CLEAR) key blinks.

3 Press SELECT key to select the CONFIG item you want to configure.

Each time you press SELECT key, the CONFIG item changes in order as shown as following. Press SELECT key repeatedly until the appropriate CONFIG item is selected.

4 Turn the rotary knob to set the condition.

5 To continue setting CONFIG items, press SELECT key. To stop setting CONFIG items, press CONFIG (SHIFT+CLEAR) key.

When you stop setting CONFIG items, the operating conditions are confirmed.

1. RS232C baud rate

Set the RS232C baud rate. Other RS232C settings are fixed.

Values: 1200 bps, 2400 bps, 4800 bps, 9600 bps, 19200 bps, 38400 bps

The supplied application software's baud rate is 9600 bps.

2. Buzzer volume when a test ends

Set the volume of the buzzer that sounds when a test ends in the range of 0 to 100.

3. Buzzer volume when an alarm occurs

Set the volume of the buzzer that sounds when an alarm occurs or when an invalid key is pressed in the range of 0 to 100.

4. Display brightness

Sets the display brightness in the range of 0 to 7.

5. Discharge counter mode

Sets whether to display the number of discharges using an incrementing or decrementing counter.

Set the mode separately for manual tests, IEC test level tests, step tests, and sequence tests.

Values: dn (): Decrementing counter
The counter value decreases for each discharge.

uP (): Incrementing counter
The counter value increases for each discharge.

6. Discharge gun trigger mode

Sets the discharge gun trigger switch mode for the case when the trigger is set to the discharge gun.

Set the mode separately for manual tests, IEC test level tests, step tests, and sequence tests.

Value: PuSH (): Push
Testing is performed while the trigger switch is being pulled.

toGG (): Toggle
Testing starts when the trigger switch is pulled. It stops when the trigger switch is pulled again.
You do not have to hold down the trigger switch in this mode.

7. Power-on panel settings

Set the condition that the KES4022A will be in when the power is turned on.

Value: init (): Start the KES4022A with all of its settings, except for the CONFIG items and memory contents, set to their factory default.

cont (): Start the KES4022A with the panel settings that were used the last time the power was on.

8. Memory protection

Set whether or not to protect the contents in memory.

Value: on (): Enable memory protection. You cannot store test conditions to memory.

oFF (): Disable memory protection. You can store test conditions to memory.

Storing and Recalling Test Conditions to/from Memory

You can store up to 20 test conditions for each operation.

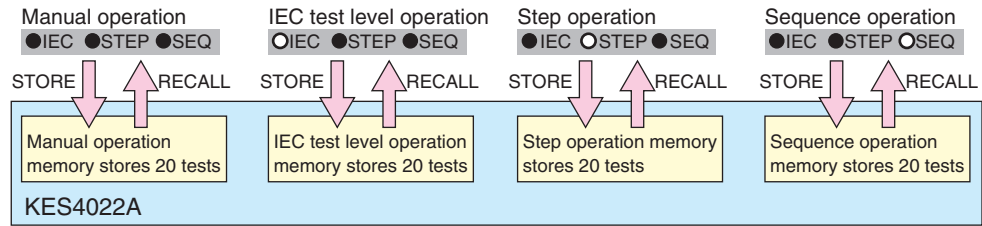

Storing test conditions to memory

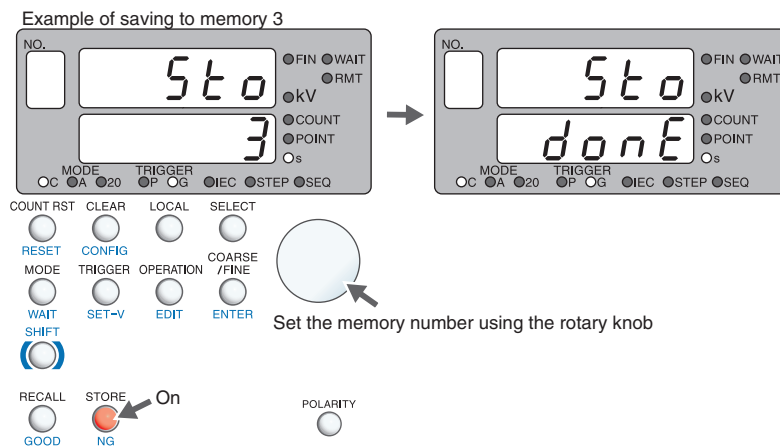

See p. 38

- 1 **Check that CONFIG setting 8 (memory protection) is off.**
If it is on, turn it off.
- 2 **Set up the configuration that you want to store.**
- 3 **Press STORE key.**
The STORE key illuminates, and the storage screen appears. The upper display shows "Sto," and the lower display shows the memory number.
- 4 **Turn the rotary knob to select the appropriate memory number.**
You can also press IEC TEST LEVEL 1, 2, 3, or 4 key to select memory number 1, 2, 3, or 4. If you select a memory number by using an IEC TEST LEVEL key, the lower display shows "donE" for a few seconds, and the settings are stored to memory. The STORE key light turns off, and the normal screen returns.
- 5 **If you select a memory number by using the rotary knob, press STORE key to store the settings.**
The lower display shows "donE" for a few seconds, the STORE key light turns off, and the normal screen returns.

Press any key other than STORE key to cancel the store operation.

See p. 38

You can use a CONFIG setting to enable memory protection to prevent overwriting the memory by mistake.

Recalling Test Conditions from Memory

To recall test conditions from memory, you can press RECALL key and select a memory number or press an IEC TEST LEVEL key (this feature is called direct recall).

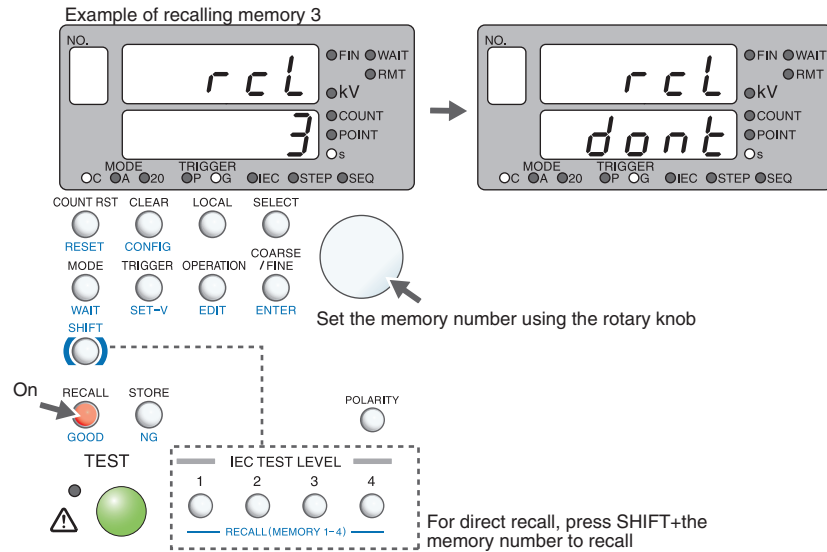

- 1 Press OPERATION key to select the test conditions you want to recall.**
- 2 Press RECALL key.**
The RECALL key illuminates, and the recall screen appears. The upper display shows "rcl," and the lower display shows the memory number.
- 3 Turn the rotary knob to select the appropriate memory number.**
If you select a memory number by using an IEC TEST LEVEL key, the lower display shows "done" for a few seconds, and the settings are recalled from memory. The RECALL light key turns off.
- 4 If you select a memory number by using the rotary knob, press RECALL key to recall the settings.**
The lower display shows "done" for a few seconds, the RECALL key light turns off, and the memory contents are recalled.

You can cancel the recall operation by pressing a key other than RECALL key.

Direct recall

You can recall the contents saved to memory numbers 1 to 4 by pressing one key.

When you recall contents from memory, the upper display shows "rcl," and the lower display shows the memory number for a few seconds.

Press SHIFT+IEC TEST LEVEL 1 key to recall contents from memory number 1.

Press SHIFT+IEC TEST LEVEL 2 key to recall contents from memory number 2.

Press SHIFT+IEC TEST LEVEL 3 key to recall contents from memory number 3.

Press SHIFT+IEC TEST LEVEL 4 key to recall contents from memory number 4.

Other Settings

Redoing a test

See p. 52

You can pause a test and redo the test. There are two ways in which you can redo it.

- Clear the number of discharges and redo the test (restart the test from number of discharges 0 at the discharge point or step that the test was paused)
Press COUNT RST key while the test is paused to clear the number of discharges. When the test is restarted, the KES4022A starts from the paused step at number of discharges 0. The discharge point is not cleared.
- Start the test from the beginning (restart the test from step 1)
Press RESET (SHIFT+COUNT RST) key while the test is paused to restart the test from step 1. In manual operation, this produces the same effect as clearing the number of discharges.

The following figure illustrates how the two ways of restarting a test are different in IEC test level operation.

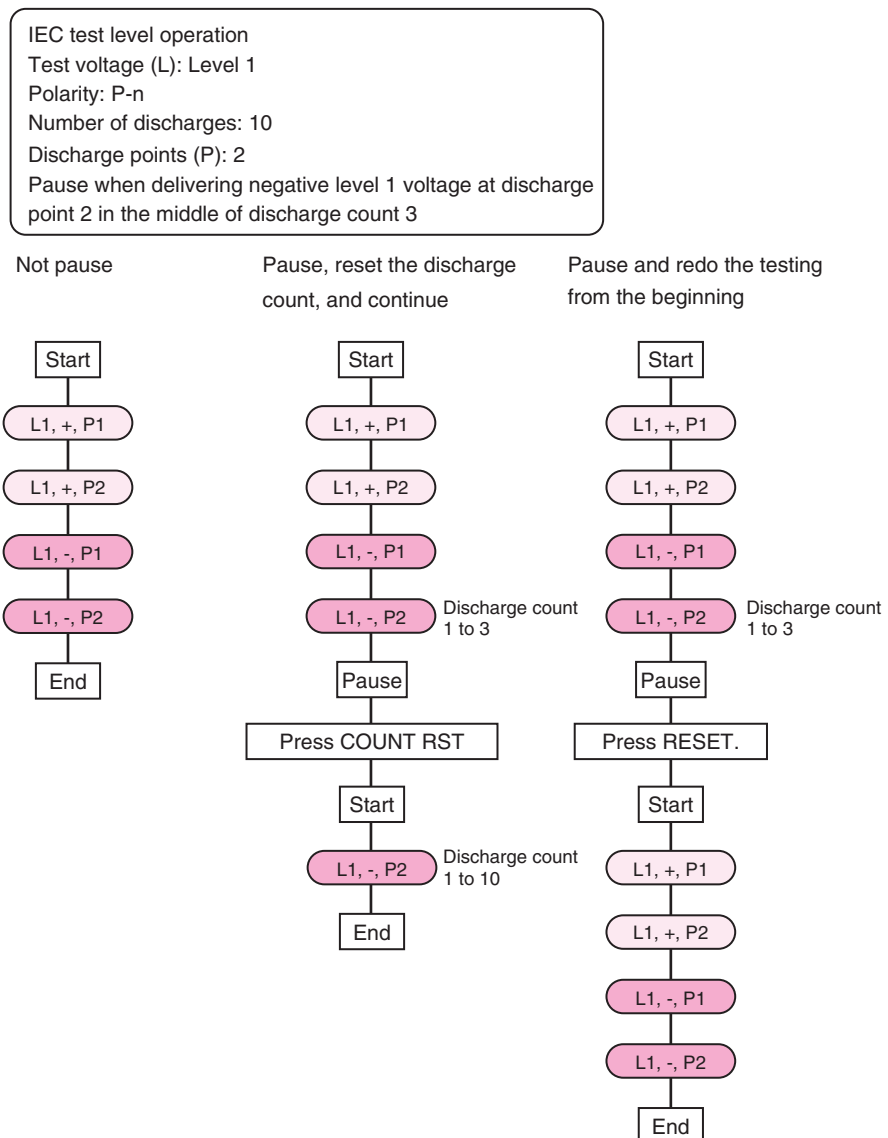

Changing the Resolution

When setting test voltages, press COARSE/FINE key to switch the resolution between 10 V and 1 kV. When the decimal point is blinking, the resolution is set to 1 kV.

When setting the number of discharges, press COARSE/FINE key to switch the resolution between 1 and 1000. When the decimal point is blinking, the resolution is set to 1000.

The resolution switches each time you press COARSE/FINE key.

Example of setting the test voltage

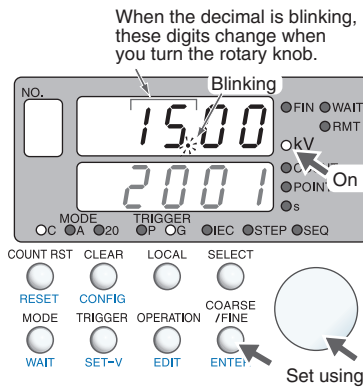

Example of setting the number of discharges

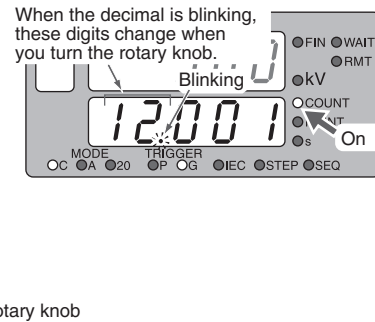

Displaying the number of times the high-voltage discharge switch has been used

Press TOTAL COUNT (SHIFT + POLARITY) key to display the number of times that the discharge gun's internal high-voltage discharge switch has been used. Use this as a reference for replacing the discharge gun.

The unit for the upper display area is 100000 times. The unit for the lower area is 1 time. Add the values in the upper and lower display areas to get the total number of times that the switch has been used.

Press TOTAL COUNT (Shift + POLARITY) key again to return to the normal screen.

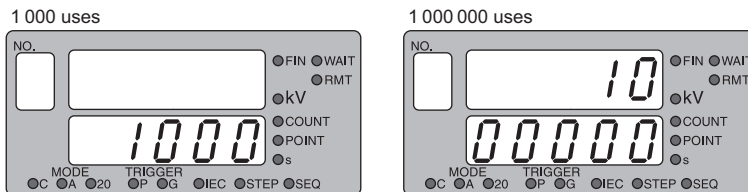

The mechanical life of the high-voltage switch is 1000000 uses. The mechanical life is approximately 1000000 uses when performing the IEC 61000-4-2 standard's level 4 test. If the voltage is twice the value that is used in this test, the mechanical life is reduced to approximately 1/4th of the expected value.

The number of times that the high-voltage switch has been used is cleared when you change the KES4022A's backup battery.



4

Performing Discharge Testing

This chapter describes manual operation, IEC test level operation, and step operation. For details on sequence operation, see the Chapter 5.



WARNING

To avoid electric shock, observe the following precautions.

- By design, the KES4022A has exposed parts that generate high voltages that are greater than or equal to 30 kV. When the KES4022A is generating high voltage, do not bring your hands close to such parts.
- During or after testing, the EUT and metal parts within the testing environment may also be charged with high voltage. Do not touch anything other than the ground reference plane during testing. Metal parts that are not electrically connected to the reference plane remain charged even after testing has been completed. Do not touch the parts until you discharge the electrical charge.
- Do not discharge to items other than the EUT, vertical coupling plane, horizontal coupling plane, or ground reference plane.
- If you notice anything abnormal about the KES4022A, turn the POWER switch off, and remove the power cord plug from the outlet. After correcting the problem, make sure that everything is safe, and then turn the power on.
- If fire, explosion, or electric shock occurs during testing, turn the KES4022A's POWER switch off, and remove the power cord plug from the outlet.
- To completely discharge the KES4022A, connect the discharge tip to GND (the ground reference plane). After discharging, turn the POWER switch off.
- Do not drop the discharge gun.

Before Testing

Prepare for testing.



To protect the PC from breakdown and from operation errors, be sure to remove the RS232C cable.

See p. 22

1 Check that the appropriate discharge tip for the test mode is attached to the discharge gun.

2 Check that a PC is not connected through the RS232C connector.
If it is, remove the cable.

See p. 28

3 Press OPERATION key to select the test mode.
The selected test mode LED illuminates. If all test mode LEDs are off, the test mode is set to manual.

See p. 29

4 Press MODE key to select the discharge mode.
The LED corresponding to the selected discharge mode illuminates on the display.

When you are finished preparing, set the test conditions.

Using the optional discharge gun stand (GS21-KES)

You can use the optional discharge gun stand to mount the discharge gun and perform testing. For more details, see the GS21-KES Operation Manual.

See p. 36

When using the gun stand, specify the panel as the test-starting trigger, and press TEST key instead of pulling the discharge gun trigger.

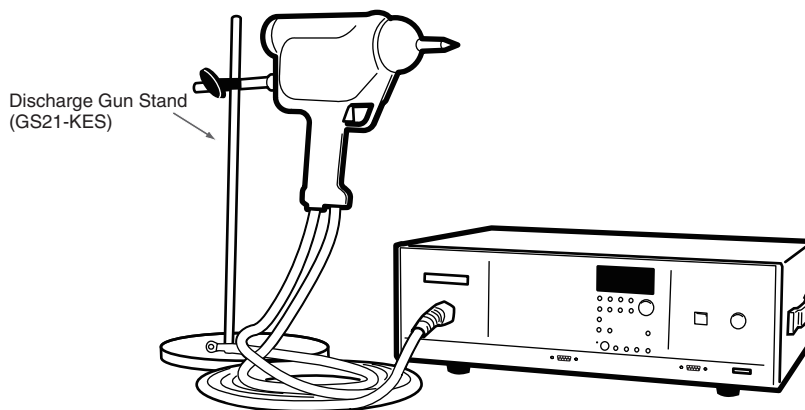

Setting Test Conditions

When you finish the test preparation, set the test conditions.

The settings vary depending on the test mode. For details on sequence operation, see “Performing Sequence Testing” in chapter 5.

	Manual operation	IEC test level operation	Step operation	See
Test voltage	Must be set. An IEC test level is also selectable.* ¹	Set the IEC test level.	Set the start voltage, stop voltage, and step voltage.	p. 30
Polarity	Enable	Enable	Enable	p. 33
Number of discharges	Enable	Enable	Enable	p. 34
Discharge interval	Enable* ²	Enable* ²	Enable* ²	p. 35
Discharge points	Disable	Enable	Enable	p. 36
Wait feature	Disable	Enable* ³	Enable* ³	p. 37

*1. In manual mode, only the selected level is tested.

*2. If 20 discharges/s or air discharge mode is selected, you cannot set the discharge interval.

*3. Cannot be set if air discharge mode is selected.

See p. 38

In addition to the settings listed above, you can set the discharge counter mode and gun trigger mode with the CONFIG settings.

When you are finished setting the test conditions, put the KES4022A into standby.

Putting the KES4022A into standby

After setting the test conditions, press HIGH VOLTAGE ON switch to put the KES4022A into standby. When you press HIGH VOLTAGE ON switch, the front-panel DANGER indicator and the discharge gun's high-voltage indicator turn on.

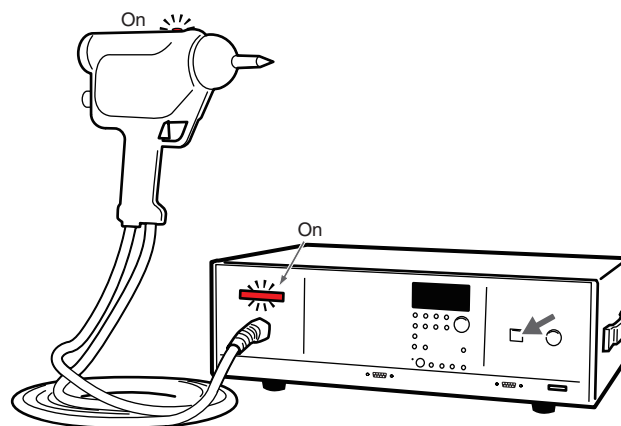

For safety reasons, the KES4022A does not generate high voltage even when you press HIGH VOLTAGE ON switch. The energy storage capacitor starts charging when you pull the discharge gun's trigger switch or when you press the front-panel TEST key. It takes approximately 0.3 seconds for the capacitor to charge.

To Start Testing

You can start discharge testing when the KES4022A is in standby.

Test procedure

If the wait feature is off, the testing of the next point or step starts approximately 3 seconds after the testing of the current point or step finishes. If the wait feature is on, a trigger starts the testing of the next point or step.

In auto operation, the buzzer sounds once when the KES4022A finishes testing a discharge point.

The buzzer sounds twice when the KES4022A finishes a step.

When all tests are finished, the buzzer sounds three times.

The following figure illustrates the test procedures for three different test conditions.

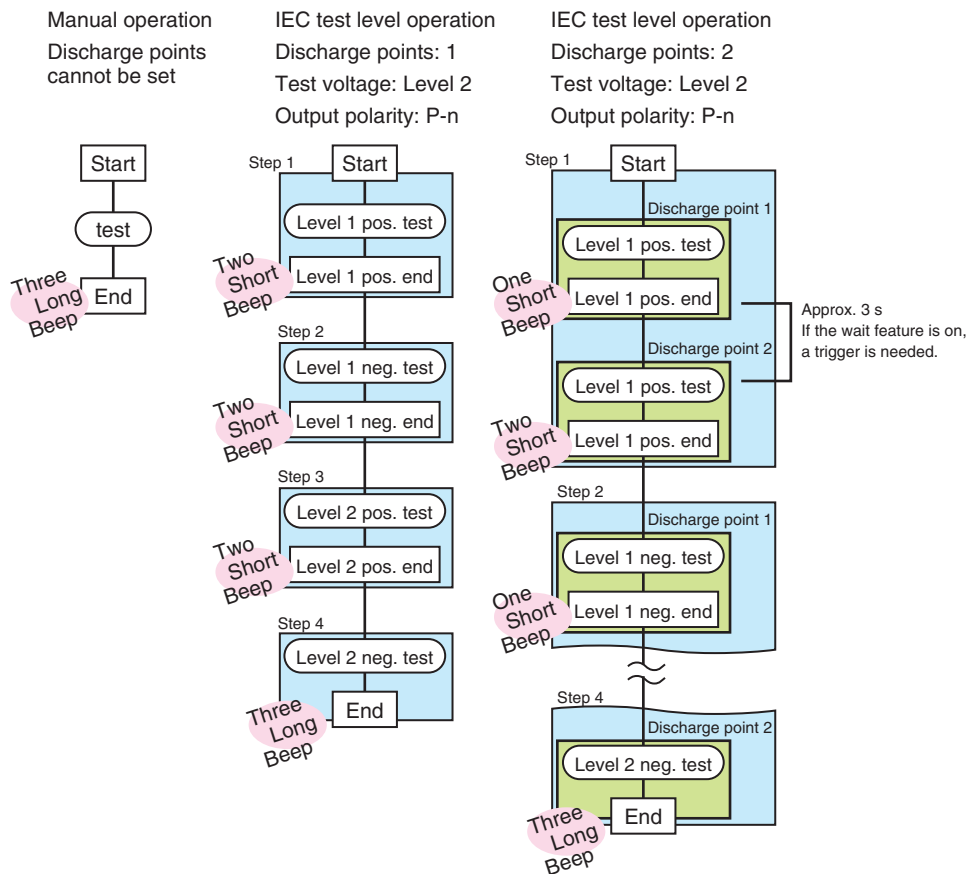

Displayed information during testing

The upper display shows the test voltage.

You can use the SELECT key to change the lower display.

When the COUNT LED is illuminated, the number of discharges is displayed.

When the POINT LED is illuminated, the current discharge point is displayed.

When the s LED is illuminated, the discharge interval is displayed.

The discharge interval is not displayed in air discharge mode. The current discharge point is not displayed in manual operation.

The TEST LED illuminates during testing.

The WAIT LED blinks from the end of the testing of a discharge point or step until the start of the testing of the next discharge point or step (approximately 3 seconds). If the wait feature is on, the WAIT LED blinks for approximately 3 seconds. Then, the WAIT LED illuminates until the next trigger.

When all tests are finished, the FIN LED illuminates, and the TEST LED turns off.

Example of a display during testing

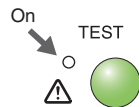
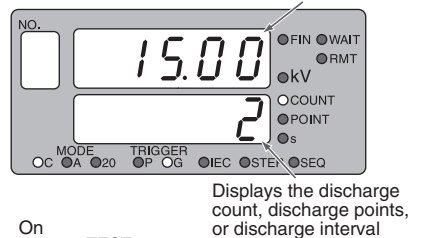

Example LED indications

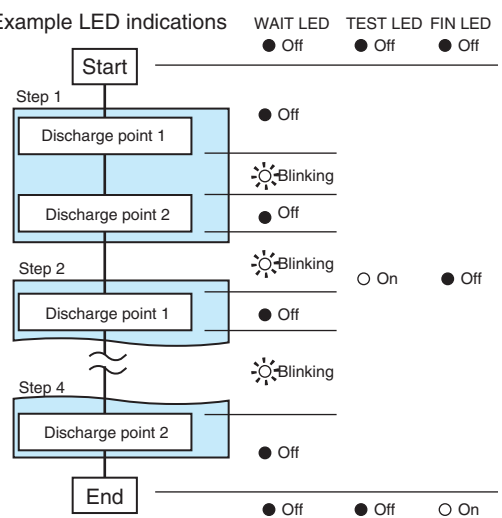

IEC test level operation

The key corresponding to the selected test level illuminates, and the key corresponding to the current IEC TEST LEVEL that the KES4022A is testing blinks.

IEC TEST LEVEL key indications during IEC test level operation

When level 3 is selected

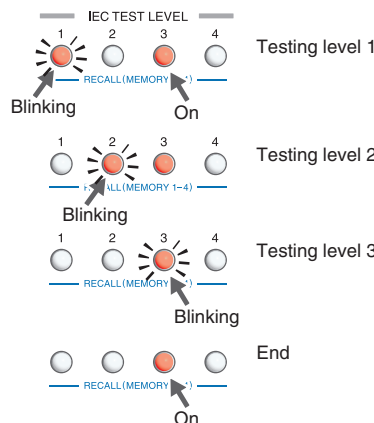

Performing contact discharge testing

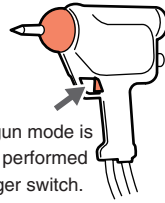
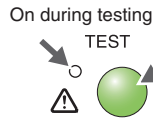

When the discharge gun mode is set to Push, testing is performed while you pull the trigger switch. When the mode is set to Toggle, pull the trigger switch and then release it. Testing is continues until you pull the trigger switch again.

Example of a display after testing

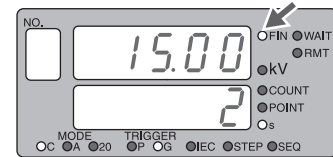

- 1 **Connect the contact discharge tip to the EUT, vertical coupling plane, or horizontal coupling plane.**
- 2 **If the trigger mode is set to PANEL, press TEST key.**
If the trigger mode is set to discharge GUN and the gun trigger mode is set to PUSH, hold down the trigger switch.
If the trigger mode is set to discharge GUN and the gun trigger mode is set to TOGGLE, pull the trigger switch.

The KES4022A will start discharging. The front panel is locked during testing except for the SELECT key and HIGH VOLTAGE OFF switches. It takes approximately 0.3 seconds for the first discharge to take place.

If the wait feature is on, you need to supply a trigger after each discharge point or step is finished.

When all specified tests are finished, the FIN LED illuminates, and the buzzer sounds three times.

If you pull the trigger switch when the FIN LED is illuminated, testing will restart.

Performing air discharge testing



Bring the discharge tip into contact with the EUT as quickly as possible. Be sure not to break the EUT when the discharge tip makes contact with it.

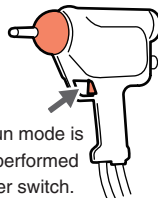
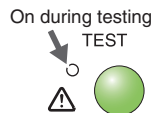

When the discharge gun mode is set to Push, testing is performed while you pull the trigger switch. When the mode is set to Toggle, pull the trigger switch and then release it. Testing is continues until you pull the trigger switch again.

Example of a display after testing

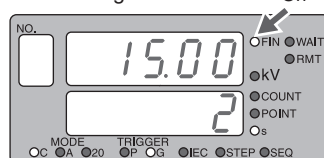

1 If the gun trigger mode is set to **PUSH**, while holding down the trigger switch, bring the air discharge tip close to the EUT as quickly as possible, and make the tip come into contact with the EUT.

If the gun trigger mode is set to **Toggle**, pull the trigger switch, bring the air discharge tip close to the EUT as quickly as possible, and make the tip come into contact with the EUT.

Air discharge takes place in this process. The front panel is locked during testing except for the SELECT key and HIGH VOLTAGE OFF switches.

2 Move the discharge gun away from the EUT.

3 If the gun trigger mode is set to **PUSH**, release the trigger switch.
If the gun trigger mode is set to **TOGGLE**, pull the trigger switch again.

The discharge counter keeps track of the number of times step 1 to step 3 are repeated.

4 Repeat step 1 to step 3 until the set number of discharges is reached.

When all specified tests are finished, the FIN LED illuminates, and the buzzer sounds three times.

If you pull the trigger switch when the FIN LED is illuminated, the discharge counter will be cleared, and testing will restart.

Pass/fail judgment

If the pass/fail criteria of EUT is not defined in the product specifications, it is decided upon the manufacturer of the EUT and the buyer. The following four classifications of test results are available. For more details, see the IEC61000-4-2 standard.

- Class a
Normal performance within specification limits
- Class b
Temporary loss of function or degradation of performance that the EUT can recover from on its own
- Class c
Temporary loss of function or degradation of performance, the correction of which requires operator intervention or system reset.
- Class d
Temporary loss of function or degradation of performance due to damage to the hardware or software, or loss of data.

To Pause and Redo Testing

You can pause testing by releasing the trigger switch (by pulling the trigger switch when the gun trigger mode is set to toGG or by pressing the TEST key when the trigger is set to Panel). The TEST LED blinks while testing is paused. The discharge counter stops at the value where testing was paused. You can resume testing from the previous value by pulling the trigger switch.

Blinks while testing is paused

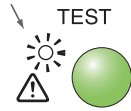

See p. 42

The KES4022A allows you to reset the number of discharges and restart testing from the discharge point or step that you paused the test at, or to restart testing from the first step.

Completion of Testing

When all tests are finished, the FIN LED illuminates, and the buzzer sounds three times.

You can stop testing before the specified number of discharges is reached by pressing HIGH VOLTAGE OFF switch.

You must perform post-testing procedures after testing has finished. Do not leave the test location without performing post-testing procedures.

Performing post-testing procedures

- 1 When testing is finished, press HIGH VOLTAGE OFF switch.**
The DANGER indicator turns off.
- 2 Connect the discharge tip to GND (ground reference plane) to discharge the remaining electric charge.**
- 3 If you are using the contact discharge tip, cover it with the protective cap.**
The contact discharge tip is sharp. Be sure to cover the tip with the protective cap when it is not in use. The protective cap is made of vinyl. If you apply strong force to the cap when it is on the tip, the tip may pierce through the cap and cause injury.



5

Performing Sequence Testing

This chapter describes how to create, execute, and edit sequence tests.

Sequence operation allows you to perform various tests continuously.

Sequence Operation Procedure

In sequence operation, you can configure up to 20 steps with different test conditions, and then perform those steps sequentially.

To perform sequence operation, press OPERATION key to switch to sequence mode.

Then, create the test conditions.

You create test conditions by adding and editing steps. (These commands appear on the screen as follows: Add, and Edit.)

You can also select steps and then insert, paste, copy, delete, erase or move them. (These commands appear on the screen as follows: inS, PASTe, coPY, dEL, ErASE, and trAnS.)

When you have finished creating the steps, execute testing.

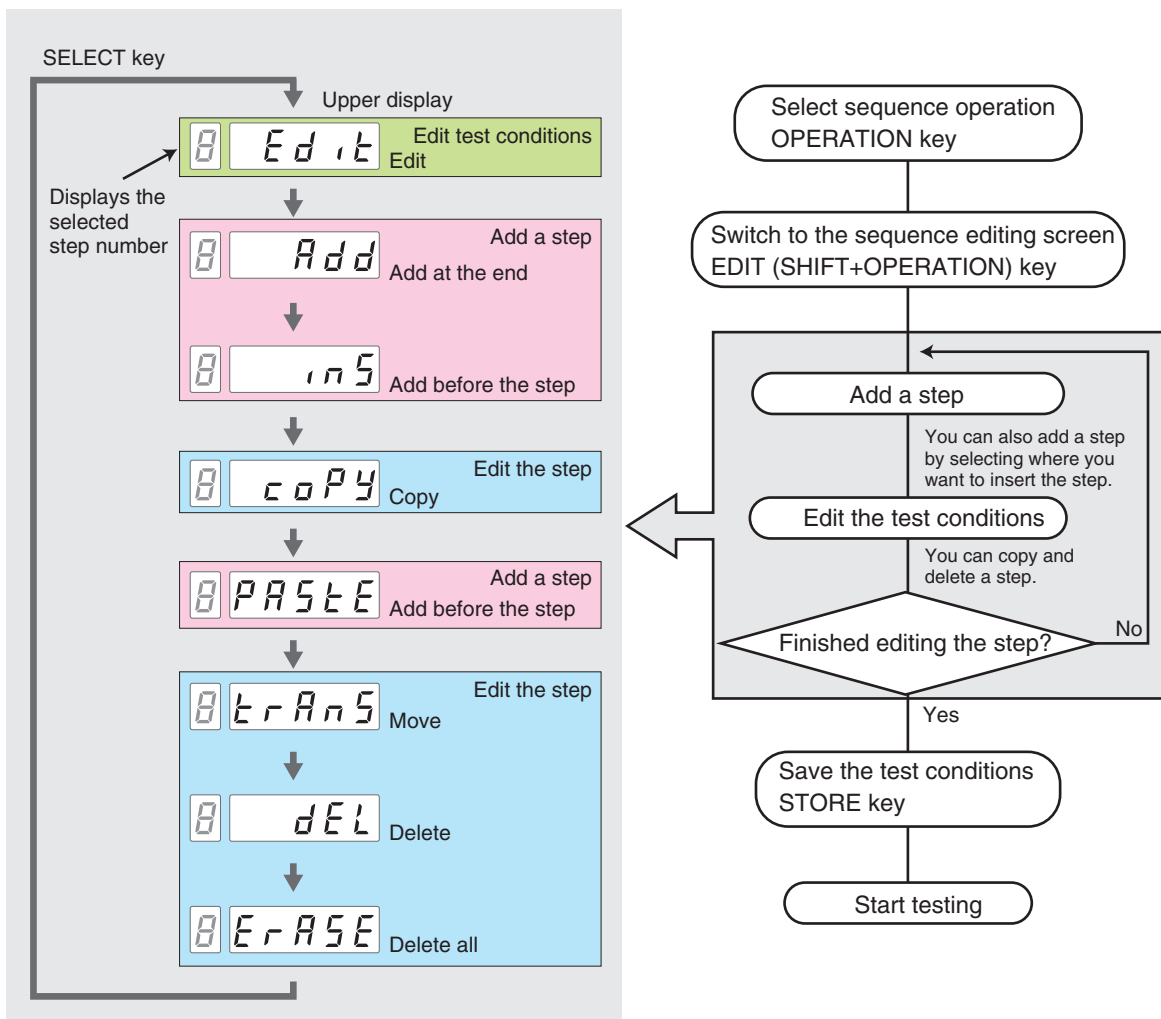

Starting Sequence Operation

Press OPERATION key until the SEQ LED turns on. The display switches to the sequence operation screen.

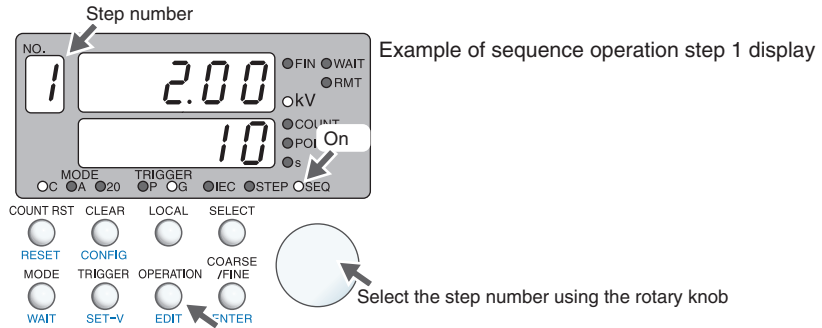

On this screen, you can view the test conditions of each step. If multiple steps are configured, you can view the test conditions of other steps by turning the rotary knob.

By factory default, the KES4022A is configured with step 1 that contains default values.

Creating a New Step

You can create a new step after you switch the panel display to the sequence operation screen.

You can:

- Create a new step after the last step.
- Create a new step before the step that you are currently editing.
- Create a new step before the step number you select.

Creating a new step after the last step

Carry out the following procedure to create a duplicate of the last step and add it to the end of the step sequence.

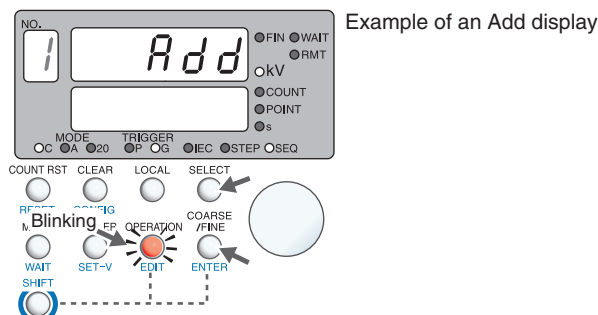

- 1 Press EDIT (SHIFT+OPERATION) key.**
The EDIT (SHIFT+OPERATION) key blinks, and the display switches to the sequence editing screen.
- 2 Press SELECT key until the upper display shows Add ().**
Press SELECT key until Add appears.
- 3 Press ENTER (SHIFT+COARSE/FINE) key.**
A new step is created after the last step.

You can press EDIT (SHIFT+OPERATION) key to cancel the operation.

Creating a new step before the step that you are currently editing

Carry out the following procedure to create a duplicate of the step that you are currently editing and insert it before the current step. This procedure is valid when there are multiple steps that have been configured.

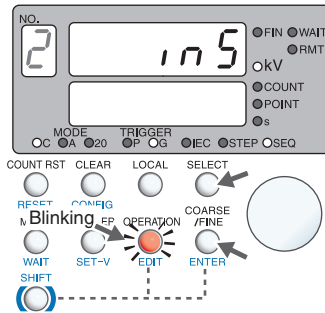

Example of an inS display

- 1 Turn the rotary knob to display the step that contains the test conditions that you want to add.**
- 2 Press EDIT (SHIFT+OPERATION) key.**
The display switches to the sequence editing screen.
- 3 Press SELECT key until the upper display shows Ins (INS).**
Press SELECT key until Ins appears.
- 4 Press ENTER (SHIFT+COARSE/FINE) key.**
A new step is inserted before the current step.

You can press EDIT (SHIFT+OPERATION) key to cancel the operation.

Creating a new step before the step number you select

Carry out the following procedure to create a duplicate of the step that you are currently editing and insert it before the selected step number. This procedure is valid when there are multiple steps that have been configured.

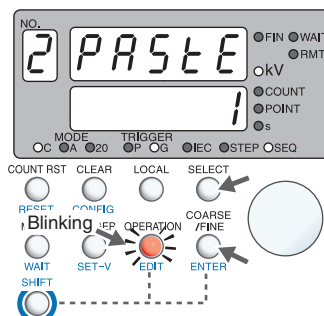

Example of copying the contents of step 2 and inserting them before step 1

- 1 Turn the rotary knob to display the step that contains the test conditions that you want to edit.**
- 2 Press EDIT (SHIFT+OPERATION) key.**
The EDIT (SHIFT+OPERATION) key blinks, and the display switches to the sequence editing screen.
- 3 Press SELECT key until the upper display shows PASTe (PASTE).**
Press SELECT key until PASTe appears. The lower display shows the step number that the new step will be inserted into.
- 4 Turn the rotary knob to select the step number you want to insert the new step into.**
- 5 Press ENTER (SHIFT+COARSE/FINE) key.**
A new step is inserted before the selected step number.

You can press EDIT (SHIFT+OPERATION) key to cancel the operation.

Editing a Step's Testing Conditions

You can change the following step testing conditions.

Test conditions that can be set individually for each step

- Test voltage
- Polarity
- Number of discharges
- Discharge interval

Test conditions that affect all steps

- Discharge mode
- Trigger
- Discharge points
- Wait feature

For test conditions that affect all steps, the test conditions that you set last take effect.

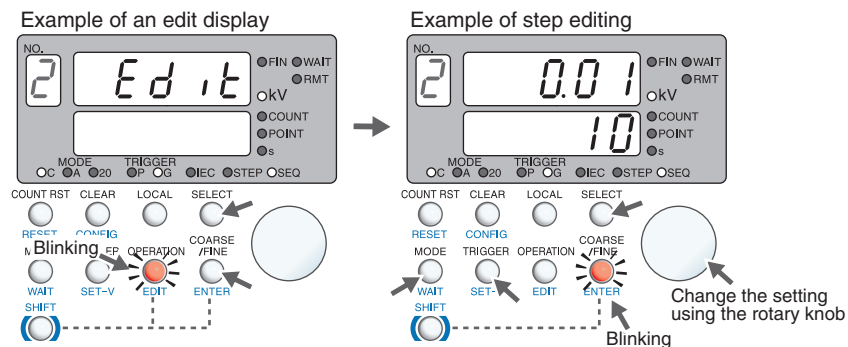

- 1 Turn the rotary knob to select the step you want to edit.**
- 2 Press EDIT (SHIFT+OPERATION) key.**
The EDIT (SHIFT+OPERATION) key blinks, and the display switches to the sequence editing screen.
- 3 Press SELECT key until the upper display shows Edit (`Edit`).**
Press SELECT key until Edit appears.
- 4 Press ENTER (SHIFT+COARSE/FINE) key.**
The ENTER (SHIFT+COARSE/FINE) key blinks, and the display switches to the step editing screen.
- 5 Change the test conditions.**
The methods for changing the test conditions are the same as with manual operation. In sequence operation, you can set the discharge points and the wait feature in addition to all of the test conditions that you can set in manual operation.
- 6 When you have finished editing the test conditions, press ENTER (SHIFT + COARSE/FINE) key.**
The test conditions change.

You can press EDIT (SHIFT+OPERATION) key to cancel the operation.

See Chapter 3

Setting the gun trigger mode and the discharge counter mode for sequence operation

See p. 38

In CONFIG settings, set the gun trigger mode and the discharge counter mode. These settings affect all steps. You cannot set these settings separately for each step.

Copying a Step's Testing Conditions

You can copy the test conditions of one step to another step. This procedure is valid when there are multiple steps that have been configured.

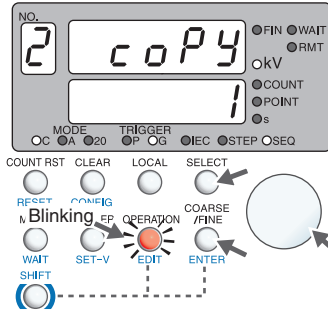

Example of Copying the contents of step 2 to step 1

- 1 Turn the rotary knob to display the step that contains the test conditions that you want to copy.**
- 2 Press EDIT (SHIFT+OPERATION) key.**
The EDIT (SHIFT+OPERATION) key blinks, and the display switches to the sequence editing screen.
- 3 Press SELECT key until the upper display shows coPy (c o P y).**
Press SELECT key until coPY appears. The lower display shows the copy destination step number.
- 4 Turn the rotary knob to select the step number you want to copy to.**
- 5 Press ENTER (SHIFT+COARSE/FINE) key.**
The test conditions are copied.

You can press EDIT (SHIFT+OPERATION) key to cancel the operation.

Moving a Step's Position

You can move the position of a step. This procedure is valid when there are multiple steps that have been configured.

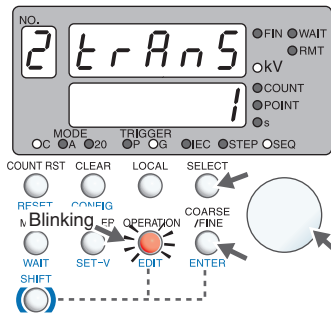

Example of moving step 2 before step 1

- 1 Turn the rotary knob to display the step that contains the test conditions that you want to move.**
- 2 Press EDIT (SHIFT+OPERATION) key.**
The EDIT (SHIFT+OPERATION) key blinks, and the display switches to the sequence editing screen.
- 3 Press SELECT key until the upper display shows trAnS (trAnS).**
Press SELECT key until trAnS appears. The lower display shows the move destination step number.
- 4 Turn the rotary knob to select the step number you want to move the step to.**
- 5 Press ENTER (SHIFT+COARSE/FINE) key.**
The step moves in front of the selected step number.

You can press EDIT (SHIFT+OPERATION) key to cancel the operation.

Deleting Steps

You can delete a specific step, or you can delete all steps at once. This procedure is only valid when there is at least one configured step.

Deleting a specific step

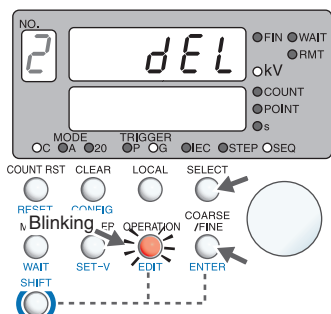

Example of a dEL display

- 1 Turn the rotary knob to select the step you want to delete.**
- 2 Press EDIT (SHIFT+OPERATION).**
The EDIT (SHIFT+OPERATION) key blinks, and the display switches to the sequence editing screen.
- 3 Press SELECT until the upper display shows dEL (dEL).**
Press SELECT until dEL appears.
- 4 Press ENTER (SHIFT+COARSE/FINE).**
The step number is deleted. If there are no steps after you delete the step, the No. display shows “—”.

You can press EDIT (SHIFT+OPERATION) key to cancel the operation.

Deleting all steps

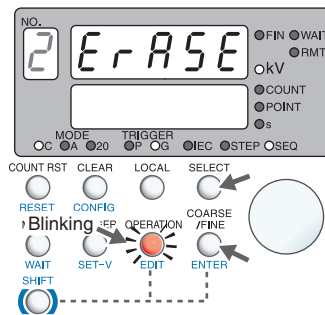

Example of an ErASE display

- 1 Press EDIT (SHIFT+OPERATION) key.**
The EDIT (SHIFT+OPERATION) key blinks, and the display switches to the sequence editing screen.
- 2 Press SELECT key until the upper display shows ErASE (ErASE).**
Press SELECT key until ErASE appears.
- 3 Press ENTER (SHIFT+COARSE/FINE) key.**
All step numbers are deleted, and the No. display shows “—”.
If you want to create a step at this point, press EDIT (SHIFT+OPERATION) key.

You can press EDIT (SHIFT+OPERATION) key to cancel the operation.

See p. 56

Examples of How to Create Sequences

This section explains how to create an ISO test level 3 sequence, as defined by performing a direct contact discharge test for category 3 of “Component immunity test method (power-up test)” in the ISO10605:2008 standard, from scratch.

- Test conditions that can be set individually for each step

Step	Test voltage	Polarity	Number of discharges	Discharge interval
1	4 kV	Positive	3	5 s
2	6 kV	Positive	3	5 s
3	8 kV	Positive	3	5 s
4	4 kV	Negative	3	5 s
5	6 kV	Negative	3	5 s
6	8 kV	Negative	3	5 s

- Test conditions that affect all steps

Only the test conditions for discharge mode are defined by the ISO standard. The procedure to create a sequence will be explained using the following test conditions.

Discharge mode: Contact Discharge
Trigger: Discharge gun
Discharge points: 3
Wait feature: On
Gun trigger mode: PuSH
Discharge counter mode: uP

Creating a sequence

Selecting sequence operation

Press OPERATION key until the SEQ LED turns on.

The display that appears when you switch the KES4022A to sequence operation varies depending on the current KES4022A conditions.

If the NO. display shows “—,” the KES4022A has no configured steps. This section will explain the procedure to create a sequence in this condition.

If the NO. display shows a step number and you want to try the procedure explained here, delete all the steps first.

If you need these steps, save them to memory before deleting them. You can store up to 20 steps for one memory.

 p. 60

 p. 40

Configuring step 1

Create step 1 and edit its test conditions. Then, set the discharge points and the wait feature that affect all steps in the sequence.

- 1 Press EDIT (SHIFT+OPERATION) key and then ENTER (SHIFT+COARSE/FINE) key.**
When you press EDIT (SHIFT+OPERATION) key, the display switches to the sequence editing screen. Because there are no steps at this point, you can only select Add. In this condition, simply press ENTER (SHIFT+COARSE/FINE) key. Step 1 is created with the default settings.
- 2 Press EDIT (SHIFT+OPERATION) key.**
The EDIT (SHIFT+OPERATION) key blinks, and the display switches to the sequence editing screen.
- 3 Press SELECT key until the upper display shows Edit (`Ed it`), and then press ENTER (SHIFT+COARSE/FINE) key.**
The ENTER (SHIFT+COARSE/FINE) key blinks, and the display switches to the step editing screen.
Next, change the test conditions for step 1. In this example, the discharge mode and trigger settings will not be changed and the default settings will be used.
- 4 Press SELECT key until the kV LED turns on, and then use the rotary knob to set the test voltage to 4.00 kV.**
- 5 Press SELECT key until the s LED turns on, and then use the rotary knob to set the discharge interval to 5 s.**
- 6 Press SELECT key until the POINT LED turns on, and then use the rotary knob to set the discharge points to 3.**
- 7 Press SELECT key until the COUNT LED turns on, and then use the rotary knob to set the number of discharges to 3.**
- 8 Press WAIT (SHIFT+MODE) key.**
The WAIT LED illuminates.
- 9 Use the rotary knob to set the wait feature to on, and then press WAIT (SHIFT+MODE) key again.**
- 10 Press ENTER (SHIFT+COARSE/FINE) key.**
You have finished setting the test conditions for step 1.

Configuring steps 2 and 3

For step 2, you will duplicate step 1 and change the test voltage. Likewise, you will create step 3 and change the test voltage.

- 1 Press EDIT (SHIFT+OPERATION) key.**
The EDIT (SHIFT+OPERATION) key blinks, and the display switches to the sequence editing screen.
- 2 Press SELECT key until the upper display shows Add (Add), and then press ENTER (SHIFT+COARSE/FINE) key.**
Step 1 is duplicated to create step 2.
- 3 Press EDIT (SHIFT+OPERATION) key.**
The EDIT (SHIFT+OPERATION) key blinks, and the display switches to the sequence editing screen.
- 4 Press SELECT key until the upper display shows Edit (Edit), and then press ENTER (SHIFT+COARSE/FINE) key.**
The ENTER (SHIFT+COARSE/FINE) key blinks, and the display switches to the step editing screen.
Next, change the test conditions for step 2.
- 5 Press SELECT key until the kV LED turns on, and then use the rotary knob to set the test voltage to 6.00 kV.**
- 6 Press ENTER (SHIFT+COARSE/FINE) key.**
You have finished setting the test conditions for step 2.
- 7 Repeat procedure 1 to procedure 6 to create step 3. For procedure 5, change the test voltage to 8.00 kV.**
You have finished configuring steps 2 and 3.

Configuring step 4

For step 4, you will copy the test conditions for step 1 and change the polarity.

- 1 Press SELECT key until the upper display shows Add (Add), and then press ENTER (SHIFT+COARSE/FINE) key.**
Step 3 is duplicated, and step 4 is created. Next, you will copy the test conditions of step 1 to step 4.
- 2 Turn the rotary knob so that the upper display shows step 1.**
The upper display indicates the copy source step number.
- 3 Press EDIT (SHIFT+OPERATION) key.**
The EDIT (SHIFT+OPERATION) key blinks, and the display switches to the sequence editing screen.
- 4 Press SELECT key until the upper display shows coPy (coPy).**
- 5 Turn the rotary knob so that the lower display shows 4.**
The lower display indicates the copy destination step number.
- 6 Press ENTER (SHIFT+COARSE/FINE) key.**
The test conditions of step 1 are copied to step 4.
- 7 Turn the rotary knob so that step 4 is displayed.**
The upper display indicates the step number that you want to edit.

- 8 Press EDIT (SHIFT+OPERATION) key.**
The EDIT (SHIFT+OPERATION) key blinks, and the display switches to the sequence editing screen.
- 9 Press SELECT until the upper display shows Edit (), and then press ENTER (SHIFT+COARSE/FINE) key.**
- 10 Press POLARITY key to display a minus sign at the left of the upper display.**
This changes the polarity of step 4.
- 11 Press ENTER (SHIFT+COARSE/FINE) key.**
You have finished configuring step 4.

Configuring steps 5 and 6

For step 5, you will copy step 4 and change the test voltage. You will create step 6 in the same way.

- 1 Press EDIT (SHIFT+OPERATION) key.**
The EDIT (SHIFT+OPERATION) key blinks, and the display switches to the sequence editing screen.
- 2 Press SELECT key until the upper display shows Add (), and then press ENTER (SHIFT+COARSE/FINE) key.**
Step 4 is duplicated, and step 5 is created.
- 3 Press EDIT (SHIFT+OPERATION) key.**
The EDIT (SHIFT+OPERATION) key blinks, and the display switches to the sequence editing screen.
- 4 Press SELECT key until the upper display shows Edit (), and then press ENTER (SHIFT+COARSE/FINE) key.**
The ENTER (SHIFT+COARSE/FINE) key blinks, and the display switches to the step editing screen. Next, change the test conditions for step 5.
- 5 Press SELECT key until the kV LED turns on, and then use the rotary knob to set the test voltage to -6.00 kV.**
- 6 Press ENTER (SHIFT+COARSE/FINE) key.**
You have finished setting the test conditions for step 5.
- 7 Repeat procedure 1 to procedure 6 to create step 6. For procedure 5, change the test voltage to -8.00 kV.**
You have finished configuring all the steps in this sequence creation example.

Starting Sequence Operation

See p. 40

We recommend that you save the steps that you created before starting sequence operation. You can configure up to 20 steps with different test conditions in a single sequence test.

See p. 38

You cannot save the steps if memory protection is enabled. Use CONFIG setting 8 to turn memory protection off.

Starting Testing

To start discharge testing by using the steps stored in memory, first recall the steps from memory.



To protect the PC from breakdown and from operation errors, be sure to remove the RS232C cable.

See p. 22

- 1 Check that the appropriate discharge tip for the test mode is attached to the discharge gun.**
- 2 Check that a PC is not connected through the RS232C connector.**
If it is, remove the cable.
- 3 Press OPERATION until the SEQ LED turns on.**
- 4 Press HIGH VOLTAGE ON switch.**
The DANGER indicator illuminates.
- 5 Pull the trigger switch.**
If the trigger mode is set to panel, press TEST key.

When testing starts

Displayed information during testing

If the wait feature is off, the WAIT LED blinks when one discharge point or step is finished. After approximately 3 seconds, the WAIT LED turns off, and the next discharge point or step starts.

If the wait feature is on, the WAIT LED blinks for approximately 3 seconds when one discharge point or step is finished. Then, the WAIT LED illuminates until the next trigger.

The NO. display shows the current step number.

The upper display shows the test voltage.

You can use the SELECT key to change the lower display. When the COUNT LED is illuminated, the number of discharges is displayed. When the s LED is illuminated, the discharge interval is displayed.

The discharge interval is not displayed in air discharge mode.

See p. 48

The buzzer sounds once when the KES4022A finishes the testing of a discharge point. The buzzer sounds twice when the KES4022A finishes a step. When all tests are finished, the FIN LED illuminates, and the buzzer sounds three times.

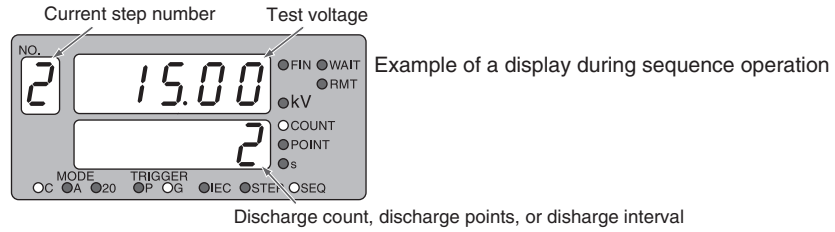

Redoing a test

See p. 52

You can pause testing by releasing the trigger switch (by pulling the trigger switch when the gun trigger mode is set to toGG or by pressing the TEST key when the trigger is set to Panel). The TEST LED blinks while testing is paused. The discharge counter stops at the value when testing was paused. You can resume testing from the previous value by pulling the trigger switch.

You can reset the discharge counter and restart testing from the last discharge point, or you can restart testing from the first step.

Pass/fail judgment

See p. 51

If the pass/fail criteria of an EUT is not defined in the product specifications, the criteria is determined between the manufacturer of the EUT and the buyer. The test results are classified into class a to d. For more details, see the IEC61000-4-2 standard.

Stopping Sequence Operation

 p. 52

You can stop testing before all steps are finished by pressing HIGH VOLTAGE OFF switch. You must perform post-testing procedures after testing has finished. Do not leave the test location without performing post-testing procedures.



6

Using the Application Software

This chapter explains how to configure and edit test conditions using the application software (KES4022A_SAMPLE_APPLICATION_SOFTWARE.xls).

Application Software Overview

In addition to using the front panel, you can configure the KES4022A test conditions from a PC through the RS232C interface. There are two methods you can use to configure the test conditions from a PC. One is to use the application software, and the other is to use commands.

The application software (KES4022A_SAMPLE_APPLICATION_SOFTWARE.xls) runs as a VBA macro on Microsoft Excel 2003.

The application software runs on Windows XP Professional (SP2 or later, 32-bit version).

■ Commands

For details on commands, see the Communication Interface Manual on the supplied CD-ROM.

The communication interface manual is provided in HTML format (a portion of the manual is in PDF format). You can view it using Microsoft Internet Explorer 5.5 or later. You can view the PDF file using Adobe Reader 6.0 or later.

You can view the Communication Interface Manual by double-clicking Index.html in the if_manual folder on the CD-ROM.

Test procedure when using the application software

This section explains the test procedure when you use the application software. You cannot remotely execute or pause testing.

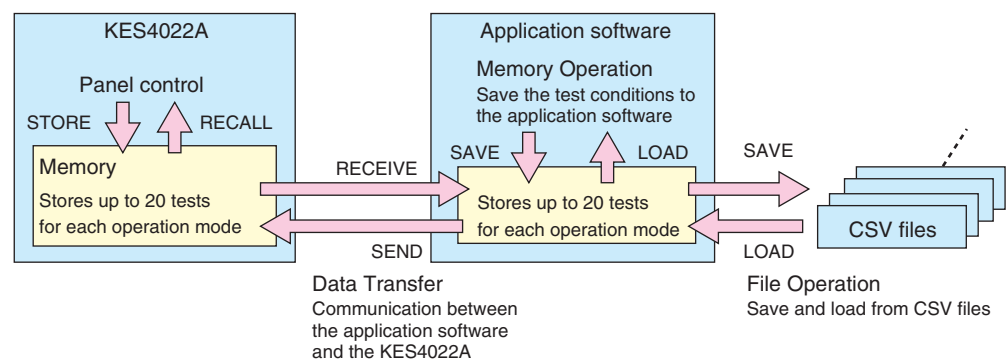

1 Configure the test conditions using the application software.

See p. 83

2 Save the test conditions in the application software.

You can save the test conditions that have been saved in the application software to a CSV file. You can also load the test conditions from a CSV file.

See p. 86

3 Send the test conditions that have been saved in the application software to the KES4022A memory.

See p. 48

4 Remove the RS232C cable, and execute the test from the panel.

You cannot remotely execute or pause testing.

Installing the Application Software

This section explains how to install the application software in the supplied CD-ROM to your PC.

- 1 Load the CD-ROM into the CD-ROM drive.**
- 2 Double-click setup.exe in the CD-ROM's apps folder.**
- 3 Follow the instructions on the screen.**

During the installation, a window for selecting the installation folder opens. Do not change the folder. If you do, the application software will not run.

When the installation is finished, the KES4022A_SAMPLE_APPLICATION_SOFTWARE.xls shortcut is created on the desktop.

Configuring RS232C

RS232C connection

The KES4022A's RS232C port is a standard D-sub, 9-pin male connector.

Check that the KES4022A and your PC are off, and connect them with a standard cross cable (null-modem cable).

Use a D-sub, 9-pin, female-to-female AT cross cable.

The KES4022A does not use hardware handshaking (which means that cross cable example 2 will suffice).

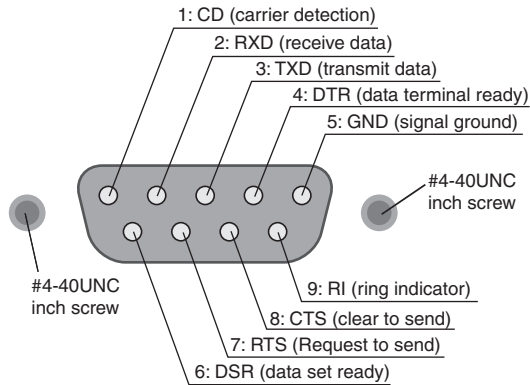

Viewed from the KES4022A front panel

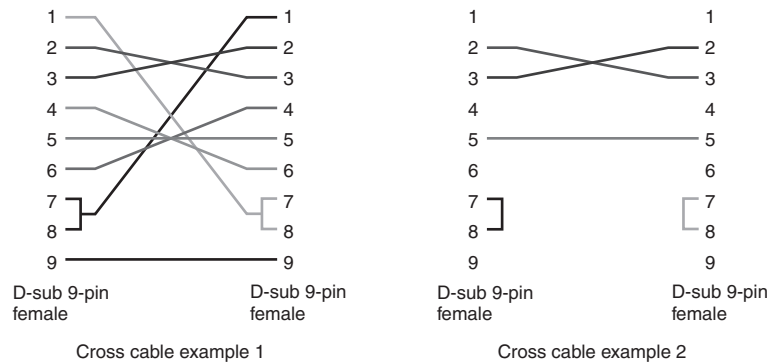

Protocol

Use CONFIG settings to set the baud rate.

The application software's baud rate is 9600 bps (by factory default).

Baud rates	1200 bps, 2400 bps, 4800 bps, 9600 bps, 19200 bps, and 38400 bps
Data length	8 bits (fixed)
Stop bits	1 bit (fixed)
Parity	None (fixed)
Flow control	XFLOW (fixed)

See p. 38

RS232C transmission and reception

Use flow control for RS232C transmission and reception. Device Control (DC) codes are used for this purpose.

Data may not be received properly if flow control is not used.

Code	Function	ASCII code
DC1 (Xon)	Send request	11H
DC3 (Xoff)	Stop-sending request	13H

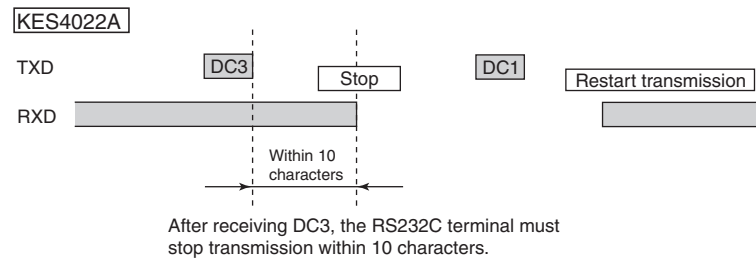

Starting the Application

After configuring the RS232C, start the application software. The application software uses the Microsoft Excel macro feature. If the macro security level is set to “High” or “Very High,” you cannot use the macro. Set the macro security level to “Medium.”

- 1 Check that the KES4022A is connected to your PC.**
If it is not, check that the KES4022A and your PC are off, and connect them with a standard cross cable (null-modem cable).
- 2 Double-click KES4022A_SAMPLE_APPLICATION_SOFTWARE.xls.**
The application software starts in Microsoft Excel.
If the KES4022A is not connected to your PC or the communication port is not configured properly, the message “OPEN error of communication port” appears. Click OK.
If the communication port is configured properly, the RMT LED illuminates.
The Confirmation of user name dialog box opens.
- 3 Enter the user name.**
- 4 If the message “OPEN error of communication port” appears, configure the communication port properly.**

See p. 82

Configuring Manual Operation

Select the Manual sheet, and configure manual operation.

1

2

3

4

5

6

7

8

9

10

11

12

13

14

15

16

17

18

19

20

21

22

23

24

25

26

27

28

29

30

31

32

*1 Specification assured range : 0 to 30.5 kV
*2 *0* means *Continuous* in this item.

Manual / IEC Test Level / Step / Sequence / Setting

Type of operation	No.	Name	Description	See
Panel settings	1	Voltage	Enter the test voltage.	p. 30
	2	Polarity	Select the polarity. Positive Negative	p. 33
	3	Discharge Interval	Enter the discharge interval.	p. 35
	4	Discharge Mode	Select the discharge mode. Contact Discharge Air Discharge 20 Discharge/s (20 discharge/s Contact Discharge)	p. 29
	5	Test Level	Set Test Level to test IEC test levels. Level1 to Level4	p. 31
	6	Number of Discharges	Enter the number of discharges. Enter 0 for infinity.	p. 34
	7	Discharge Count	Select the discharge counter mode. Increments Decrements	p. 39
	8	Trigger	Select the trigger mode. PANEL GUN-PUSH (discharge gun in push mode) GUN-TOGGLE (discharge gun in toggle mode)	p. 36 p. 39
Memory operation	9	No.	Select the memory number you want to edit. Memory1 to Memory20	p. 40
	10	Comment	Enter comments (up to 20 characters).	p. 83
	11	LOAD	Load test conditions.	p. 85
	12	SAVE	Save test conditions.	p. 83
File Operation	13	LOAD	Load data from a CSV file.	p. 85
	14	SAVE	Save data to a CSV file.	p. 84
Data Transfer	15	SEND	Send saved test conditions to the KES4022A memory.	p. 86
	16	RECEIVE	Receive the KES4022A memory contents.	p. 86

Configuring IEC Test Level operation

Select the IEC Test Level sheet, and configure the IEC test level operation.

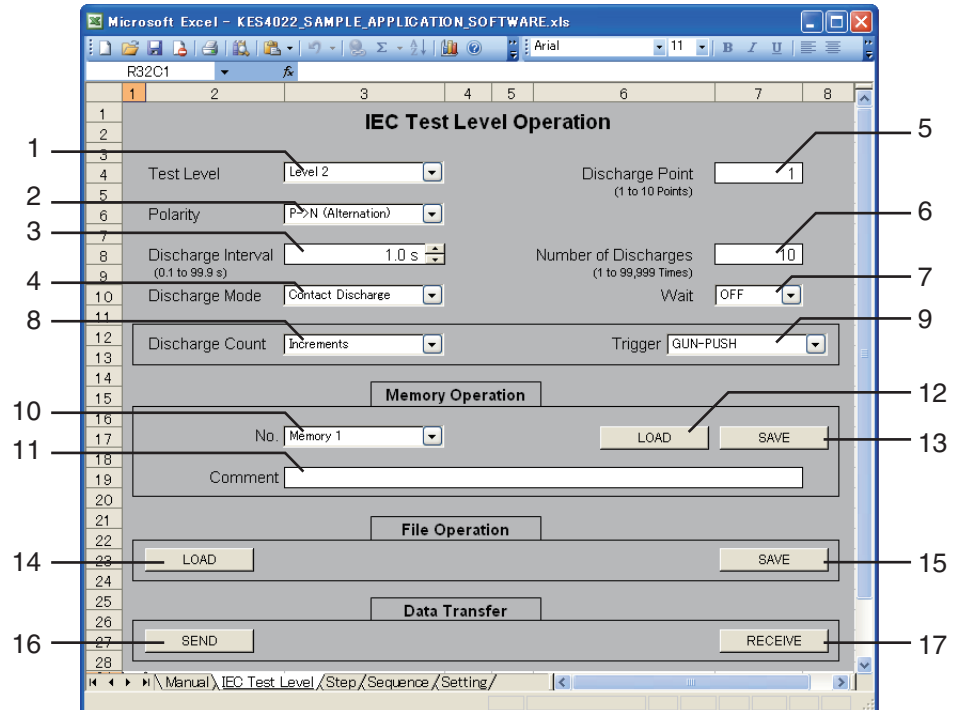

Type of operation	No.	Name	Description	See
Panel settings	1	Test Level	Select the IEC test level. Level1 to Level4	p. 31
	2	Polarity	Select the polarity. Positive Negative P->N (Alternation): Start with a positive voltage and switch the polarity for each step N->P (Alternation): Start with a negative voltage and switch the polarity for each step P->N (One by One): Test all positive steps and then all negative steps N->P (One by One): Test all negative steps and then all positive steps	p. 33
	3	Discharge Interval	Enter the discharge interval.	p. 35
	4	Discharge Mode	Select the discharge mode. Contact Discharge Air Discharge 20 Discharge/s (20 discharge/s Contact Discharge)	p. 29
	5	Discharge Point	Enter the discharge points.	p. 36
	6	Number of Discharges	Enter the number of discharges.	p. 34
	7	Wait	Wait feature ON OFF	p. 37
	8	Discharge Count	Select the discharge counter mode. Increments Decrements	p. 39
	9	Trigger	Select the trigger mode. PANEL GUN-PUSH (discharge gun in push mode) GUN-TOGGLE (discharge gun in toggle mode)	p. 36 p. 39
Memory operation	10	No.	Select the memory number you want to edit. Memory1 to Memory20	p. 40
	11	Comment	Enter comments (up to 20 characters).	p. 83
	12	LOAD	Load test conditions.	p. 85
	13	SAVE	Save test conditions.	p. 83
File operation	14	LOAD	Load data from a CSV file.	p. 85
	15	SAVE	Save data to a CSV file.	p. 84
Data Transfer	16	SEND	Send saved test conditions to the KES4022A memory.	p. 86
	17	RECEIVE	Receive the KES4022A memory contents.	p. 86

Configuring Step Operation

Select the Step sheet, and configure step operation.

The screenshot displays the 'Step Operation' configuration sheet in Microsoft Excel. The sheet is titled 'Step Operation' and contains various input fields and buttons for configuring step operation parameters. The following table summarizes the key elements and their corresponding callout numbers:

Callout Number	Field/Element	Value/Setting
1	Voltage Setting (0.01 to 30.50 kV) *1	2.00 kV
2	Starting Voltage	2.00 kV
3	Test Level	[Dropdown]
4	Stop Voltage	4.00 kV
5	Test Level	[Dropdown]
6	Step Voltage	0.50 kV
7	Polarity	P->N (Alternation)
8	Discharge Interval (0.1 to 99.9 s)	1.0 s
9	Discharge Point (1 to 10 Points)	1
10	Number of Discharges (1 to 99,999 Times)	10
11	Discharge Mode	Contact Discharge
12	Wait	OFF
13	Discharge Count	Increments
14	Trigger	GUN-PUSH
15	Memory No.	Memory 1
16	Memory Operation Buttons	LOAD, SAVE
17	Comment	[Text Field]
18	File Operation Buttons	LOAD, SAVE
19	Data Transfer Buttons	SEND, RECEIVE
20	SEND Button	SEND
21	RECEIVE Button	RECEIVE

Additional notes from the sheet:

- *1 Specification assured range : 0.01 to 30.50 kV
- Path: Manual \ IEC Test Level \ Step \ Sequence \ Setting \

Type of operation	No.	Name	Description	See
Voltage settings (panel settings)	1	Starting Voltage	Enter the start voltage.	p. 32
	2	Test Level (Starting Voltage)	Select the test level when setting the start voltage in terms of an IEC test level. Level1 to Level4	p. 31
	3	Step Voltage	Enter the step voltage.	p. 32
	4	Stop Voltage	Enter the stop voltage.	p. 32
	5	Test Level (End voltage)	Set Test Level to set the stop voltage in terms of an IEC test level. Level1 to Level4	p. 31
Panel settings	6	Polarity	Select the polarity. Positive Negative P->N (Alternation): Start with a positive voltage and switch the polarity for each step N->P (Alternation): Start with a negative voltage and switch the polarity for each step P->N (One by One): Test all positive steps and then all negative steps N->P (One by One): Test all negative steps and then all positive steps	p. 33
	7	Discharge Interval	Enter the discharge interval.	p. 35
	8	Discharge Mode	Select the discharge mode. Contact Discharge Air Discharge 20 Discharge/s (20 discharge/s Contact Discharge)	p. 29
	9	Discharge Point	Enter the discharge points.	p. 36
	10	Number of Discharges	Enter the number of discharges.	p. 34
	11	Wait	Wait feature ON OFF	p. 37
	12	Discharge Count	Select the discharge counter mode. Increments Decrements	p. 39
	13	Trigger	Select the trigger mode. PANEL GUN-PUSH (discharge gun in push mode) GUN-TOGGLE (discharge gun in toggle mode)	p. 36 p. 39
Memory operation	14	No.	Select the memory number you want to edit. Memory1 to Memory20	p. 40
	15	Comment	Enter comments (up to 20 characters).	p. 83
	16	LOAD	Load test conditions.	p. 85
	17	SAVE	Save test conditions.	p. 83
File operation	18	LOAD	Load data from a CSV file.	p. 85
	19	SAVE	Save data to a CSV file.	p. 84
Data Transfer	20	SEND	Send saved test conditions to the KES4022A memory.	p. 86
	21	RECEIVE	Receive the KES4022A memory contents.	p. 86

Configuring Sequence Operation

Select the Sequence sheet, and configure sequence operation.

The screenshot shows the 'Sequence Operation' configuration sheet in Microsoft Excel. The sheet is titled 'Sequence Operation' and contains several sections: 'Discharge Operation', 'Memory Operation', 'File Operation', and 'Data Transfer'. Each section has various input fields and buttons. A blue character '1' is used for certain values, indicating they are shared across test sequences. Numbered callouts (1-20) point to specific elements in the interface.

Discharge Operation:

- Voltage (0.01 to 30.50 kV) *1: 0.01 kV
- Test Level: [Dropdown]
- Polarity: Positive
- Discharge Point (1 to 10 Points): 1
- Discharge Interval (0.1 to 99.9 s): 1.0 s
- Number of Discharges (1 to 99,999 Times): 10
- Discharge Mode: Contact Discharge
- Wait: OFF
- Discharge Count: Increments
- Trigger: GUN-PUSH

Memory Operation:

- No.: Memory 1
- End Step: 1
- Step: Step 1
- Buttons: Step LOAD, Step SAVE
- Comment: [Text Field]

File Operation:

- Buttons: LOAD, SAVE

Data Transfer:

- Buttons: SEND, RECEIVE

Notes:

- The item written by a blue character is using same set value in each test sequence.
- *1 Specification assured range : 0.01 to 30.50 kV

The sheet is titled 'R58C1' and the window title is 'Microsoft Excel - KES4022_SAMPLE_APPLICATION_SOFTWARE.xls'. The sheet is located at 'Manual \IEC Test Level \Step \Sequence \Setting/'.

Type of operation	No.	Name	Description	See
Panel settings	1	Voltage	Enter the test voltage.	p. 30
	2	Polarity	Select the polarity. Positive Negative	p. 33
	3	Discharge Interval	Enter the discharge interval.	p. 35
	4	Discharge Mode	Select the discharge mode. Contact Discharge Air Discharge 20 Discharge/s (20 discharge/s Contact Discharge)	p. 29
	5	Test Level	Set Test Level to test IEC test levels. Level1 to Level4	p. 31
	6	Discharge Point	Enter the discharge points.	p. 36
	7	Number of Discharges	Enter the number of discharges.	p. 34
	8	Wait	Wait feature ON OFF	p. 37
	9	Discharge Count	Select the discharge counter mode. Increments Decrements	p. 39
	10	Trigger	Select the trigger mode. PANEL GUN-PUSH (discharge gun in push mode) GUN-TOGGLE (discharge gun in toggle mode)	p. 36 p. 39
Memory operation	11	No.	Select the memory number you want to edit. Memory1 to Memory20	p. 40
	12	Step	Select the step number you want to edit. Step1 to Step20	p. 83
	13	End Step	Select the end step number (testing is performed up to the selected step). Step1 to Step20	p. 83
	14	Comment	Enter comments (up to 20 characters).	p. 83
	15	Step LOAD	Load test conditions.	p. 85
	16	Step SAVE	Save test conditions.	p. 83
File operation	17	LOAD	Load data from a CSV file.	p. 85
	18	SAVE	Save data to a CSV file.	p. 84
Data Transfer	19	SEND	Send saved test conditions to the KES4022A memory.	p. 86
	20	RECEIVE	Receive the KES4022A memory contents.	p. 86

Configuring Communication Settings

Select the Setting sheet, and configure communication settings. You can also save and load all testing conditions from a CSV file.

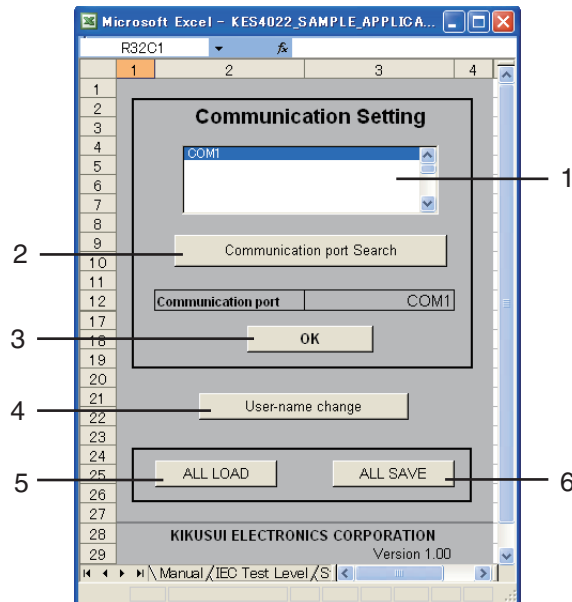

Type of operation	No.	Name	Description	See
Communication settings	1	Communication port	Displays the communication port.	p. 82
	2	Communication port Search	Search for communication ports.	p. 82
	3	OK	Confirm the selected communication port.	p. 82
User name setting	4	User-name change	Change the user name.	—
File operation	5	ALL LOAD	Load a CSV file that has been saved with the ALL SAVE command.	p. 85
	6	ALL SAVE	Save up to 20 test conditions of each testing to a CSV file.	p. 84

Setting the communication port

If you start the application software and the message “OPEN err of communication port” appears, configure the communication port properly. If the communication port is configured properly, the RMT LED illuminates.

- 1** Select the Setting sheet.
- 2** Click **Communication port Search**.
Search for communication ports.
- 3** Select the appropriate port, and click **OK**.
- 4** Close the application.
Click **OK** when the following message appears: “Setting is updated!! This workbook will be closed.” The communication port is confirmed, and the application closes.
- 5** Restart the application.

Saving and Loading Test Conditions

Saving test conditions

This section explains how to save the test conditions in the application software and how to export the saved test conditions to a CSV file.

Saving test conditions in the application software

Save the test conditions in the application software. You can save up to 20 sets of test conditions for each operation to memories 1 to 20.

■ Manual operation, IEC test level operation, and step operation

- 1 Select the testing sheet you want to save, and set the test conditions.**
- 2 In the *No.* box under Memory Operation, enter the memory number you want to save to.**
- 3 If you want to, enter comments in the *Comment* box under Memory Operation.**
You can enter comments using up to 20 characters.
- 4 Click *SAVE* under Memory Operation.**
The test conditions are saved in the application software.

■ Sequence operation

In sequence operation, save the test conditions for each step (up to 20 steps in one memory location).

- 1 Select the Sequence sheet, and set the step's test conditions.**
- 2 In the *No.* box under Memory Operation, enter the memory number you want to save to.**
- 3 In the *Step* box under Memory Operation, enter the step number you want to save.**
- 4 In the *End Step* box under Memory Operation, enter the end step of the memory location.**
If you specify different end step values for a given memory location, the last value that you specify takes effect. Even if you set the end step to a value less than the step number, the step is saved. However, when testing is actually performed, it stops at the step number specified for End Step.
- 5 If you want to, enter comments in the *Comment* box under Memory Operation.**
You can enter comments using up to 20 characters. If you specify different comments for a given memory location, the last comment that you enter takes effect.
- 6 Click *Step SAVE* under Memory Operation.**
The step's test conditions are saved in the application software. To configure other steps, repeat procedure 1 to procedure 6 .

Exporting test conditions to a CSV file

This section explains how to export the test conditions that have been saved in the application software to a CSV file. Do not change the contents of the CSV file directly.

■ Exporting the test conditions of a specific operation

Carry out the procedure below to export the test conditions of a specific operation.

- 1 Select the operation sheet that you want to save.**
- 2 Click *SAVE* under Memory Operation to save the test conditions in the application software.**
You can save up to 20 sets of test conditions for each operation.
- 3 Click *SAVE* under File Operation.**
- 4 Enter the file name and save the file.**

 p. 83

■ Exporting the test conditions of all operations

Carry out the procedure below to export all test conditions that have been saved in the application software.

- 1 Click *SAVE* under Memory Operation to save the test conditions in the application software.**
You can save up to 20 sets of test conditions for each operation.
- 2 Select the Setting sheet, and click *ALL SAVE*.**
- 3 Enter the file name and save the file.**

 p. 83

Loading test conditions

This section explains how to recall the test conditions that have been saved in the application software. You can also load the test conditions that have been exported to a CSV file.

Do not change the contents of the CSV file directly. If you load a file that you have changed directly into the application and send the test conditions to the KES4022A, an unexpected error may occur, or the KES4022A may stop working.

Recalling the test conditions that have been saved in the application software

You can recall test conditions from the application software to view or change them.

■ Manual operation, IEC test level operation, and step operation

- 1** Select the operation sheet that you want to recall.
- 2** Enter the memory number you want to recall from in the *No.* box under Memory Operation.
- 3** Click **LOAD** under Memory Operation.
The test conditions are recalled.

■ Sequence operation

In sequence operation, test conditions are recalled in steps.

- 1** Select the Sequence sheet.
- 2** Enter the memory number you want to recall from in the *No.* box under Memory Operation.
- 3** Enter the step number you want to recall in the *Step* box under Memory Operation.
- 4** Click **Step LOAD** under Memory Operation.
The test conditions are recalled.

Loading a CSV file

You can load the test conditions that have been exported to a CSV file into the application software.

■ Loading the test conditions for a specific operation

Carry out the procedure below to load the test conditions of a specific operation.

- 1** Select the operation sheet that you want to load the test conditions into.
- 2** Click **LOAD** under File Operation.
- 3** Select the name of the file you want to load, and load the test conditions.

■ Loading the test conditions of all operations

Carry out the procedure below to load the test conditions of all operations.

- 1** Select the Setting sheet, and click **ALL LOAD**.
- 2** Select the name of the file you want to load, and load the test conditions.

Communication with the KES4022A

This section explains how to send the test conditions that have been saved in the application software to the KES4022A memory and how to load test conditions from the KES4022A memory into the application software.



WARNING

- To avoid electric shock, do not allow the KES4022A communicate with the PC when the KES4022A's DANGER indicator is illuminated.



CAUTION

- To perform a discharge test, be sure to remove the RS232C cable. If you do not remove the cable, the PC may break or operate improperly.

Sending the test conditions that have been saved in the application to the KES4022A

Carry out the procedure below to send the test conditions of a specific operation that have been saved in the application software to the KES4022A.

- 1 Check that the KES4022A's DANGER indicator is off.**
If not, press HIGH VOLTAGE OFF switch.
- 2 Select the operation sheet that you want to send.**
- 3 Click *SAVE* under Memory Operation to save the test conditions in the application software.**
You can save up to 20 sets of test conditions for each operation.
- 4 Click *SEND* under Data Transfer.**
The test conditions that have been saved in the application software are sent to the KES4022A.

See p. 83

Retrieving the test conditions from the KES4022A memory using the application software

Carry out the procedure below to load the test conditions of a specific operation from the KES4022A memory into the application software.

- 1 Check that the KES4022A's DANGER indicator is off.**
If not, press HIGH VOLTAGE OFF switch.
- 2 Select the operation sheet that you want to load the test conditions into.**
- 3 Click *RECEIVE* under Data Transfer.**
The test conditions are loaded into the application software.



7

Specifications

This chapter contains the KES4022A specifications and outline drawings.

Unless specified otherwise, the specifications are for the following settings and conditions.

- The warm-up time is 30 minutes.
- rdng: Indicates the readout value.
- set: Indicates the setting value.

Discharge current waveform (Contact Discharge mode)

Meets the waveform parameter requirements indicated in the IEC61000-4-2 Edition 1.2 2001-4 standard (using the waveform monitoring apparatus specified in Annex B of the IEC61000-4-2 Edition 1.2 2001-4 standard).

The items and values are excerpts from the IEC61000-4-2 standard.

In the range of 15 °C to 35 °C and 30 %rh to 60 %rh (no condensation).

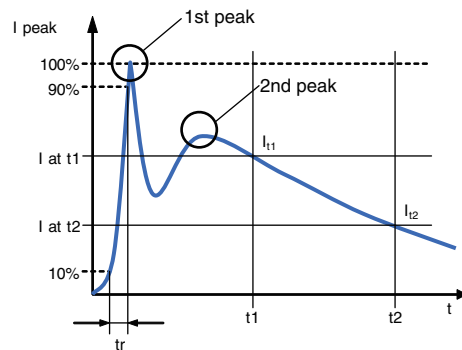

IEC-compliant mode (150 pF/330 Ω (CR31-KES))

IEC test level	LEVEL1	LEVEL2	LEVEL3	LEVEL4
Charge voltage	2 kV	4 kV	6 kV	8 kV
1st peak current ^{*1}	7.5 A ± 10 %	15 A ± 10 %	22.5 A ± 10 %	30 A ± 10 %
Rise time ^{*2} (tr)	0.8 ns +25 % -12.5 %			
Current at 30 ns (I 30)	4 A ± 30 %	8 A ± 30 %	12 A ± 30 %	16 A ± 30 %
Current at 60 ns (I 60)	2 A ± 30 %	4 A ± 30 %	6 A ± 30 %	8 A ± 30 %

*1. Defined in accordance with ISO standards. The accuracy is defined as ± 15 % in the IEC standard.

*2. Defined in accordance with ISO standards. The accuracy is defined as ± 25 % in the IEC standard.

IEC/ISO-compliant model

(ISO-standard waveforms produced by the 150 pF/330 Ω CR unit (CR31-KES) is defined according to the specifications of IEC-compliant model.)

CR unit	330 pF/ 330 Ω (CR32-KES)	150 pF/ 2 kΩ (CR33-KES)	330 pF/ 2 kΩ (CR34-KES)
1st peak current ^{*1}	3.75 A/kV ± 10 %	3.75 A/kV +30 % -0%	
Rise time (tr) ^{*1}	0.7 ns to 1.0 ns (from 10 % to 90 %)		
Current at t1 (It1) ^{*1}	2 A/kV ± 30 % (t1: 65 ns)	0.275 A/kV ± 30 % (t1: 180 ns)	0.275 A/kV ± 30 % (t1: 400 ns)
Current at t2 (It2) ^{*1}	1 A/kV ± 30 % (t2: 130 ns)	0.15 A/kV ± 30 % (t2: 360 ns)	0.15 A/kV ± 30 % (t2: 800 ns)

*1. Defined according to IEC test level.

Features and Performance

Compliant standard	IEC-compliant model	IEC61000-4-2 Ed.2.0 2008-12
	IEC/ISO-compliant model	IEC61000-4-2 Ed.2.0 2008-12 ISO 10605 Ed.2.0 2008-07
Discharge methods		Air discharge and contact discharge
Test voltage ^{*1}	Setting range ^{*2}	0.5 kV to 30 kV
	Accuracy ^{*3}	±5 % of set (2 kV or higher)
		±(5 % of set + 5 digits) (less than 2 kV)
	Resolution	0.01 kV
Polarity	Positive or negative	
CR unit	Energy storage capacitor ^{*4}	150 pF ± 10 % 330 pF ± 10 % ^{*5}
	Discharge resistor ^{*3}	330 Ω ± 10 % 2 k Ω ± 10 %
Charge resistor		50 MΩ ^{*6}
Operations		Manual operation, IEC test level operation, step operation, and sequence operation ^{*7}
Discharge interval		0.05 s, 0.1 s to 99.9 s ± (2 % of set + 1 ms)
Number of discharges		1 to 99999, or infinity ^{*8}
Discharge points ^{*9}		1 point to 10 points
Wait feature ^{*9}		On or off
Memory		Stores 20 sets of testing conditions for each operation (a total of 80 sets)
Method to start discharge		Trigger switch or TEST key

- *1. Voltage across the energy storage capacitor terminals
- *2. Allowable range of the setting: 0 kV to 30.50 kV
Out of range of the specification: 0 kV to 0.5 kV, 30 kV to 30.50 kV
- *3. Ambient temperature: At 15 °C to 35 °C
- *4. Temperature coefficient: Approx. -0.5 %/°C, Ambient temperature: At 23 °C
- *5. IEC/ISO-compliant model only
- *6. Nominal value
- *7. You can configure up to 20 steps with different test conditions in a single sequence test.
- *8. Infinity is only valid for manual operation.
- *9. Excludes manual operation

Safety features

DANGER indicator	Illuminates when the internal high-voltage source is on.
High-voltage indicator	Illuminates when the internal high-voltage source is on.
High-voltage stop feature	Stops the generation of high-voltage source when the discharge gun's CR unit cap is not closed.
Protective cap	Protective cap for the contact discharge tip.
Charge method	The high-voltage source is off in standby. The high-voltage source output turns on approximately 0.3 seconds before the start of discharge.

RS232C interface

Connector	Front-panel D-sub, 9-pin connector (complies with EIA-232D)
Protocol	Data length: 8 bits Stop bits: 1 bit Parity bit: None Flow control: XFLOW Baud rates: 1200 bps, 2400 bps, 4800 bps, 9600 bps, 19200 bps, and 38400 bps

Application software (KES4022A_SAMPLE_APPLICATION_SOFTWARE.xls)

Operating system	Windows XP Professional (SP2 or later, 32-bit version)
Application requirement	Microsoft Excel 2003 VBA Runs as a macro program.
Baud rate	9600 bps

General specifications

Nominal input rating		100 Vac to 240 Vac, 50 Hz to 60 Hz	
Input voltage range		90 Vac to 250 Vac	
Power consumption		90 VAm _{ax} (at 30 kV output)	
Inrush current (at 250 Vac)		Max. 100 A _{peak} (20 ms or less)	
Operating temperature and humidity ranges		10 °C to 40 °C (50 °F to 104 °F) and 10 %rh to 80 %rh (no condensation)	
Storage temperature and humidity ranges		-5 °C to 70 °C (23 °F to 158 °F) and 10 %rh to 80 %rh (no condensation)	
Operating environment		Indoors	
Maximum altitude		1300 m above sea level	
Insulation resistance	Between the primary circuit and the chassis	30 MΩ or greater at 500 Vdc	
Withstand voltage	Between the primary circuit and the chassis	No abnormality at 1500 Vac over 1 minute	
Earth continuity	Between the ground pin of AC inlet and the chassis	25 Aac, 0.1 Ω or less	
Outline drawing	Discharge gun	See the outline drawing. ^{*1}	
	Main unit	See the outline drawing.	
Wight	Discharge gun ^{*2}	Approx. 1.5 kg (3.3 lb)	
	Main unit	Approx. 8 kg (17.6 lb)	
Backup battery life		Approx. 3 years	
Accessories ^{*3}	Power cord	1 pc.	
	Air discharge tip	AT31-KES ^{*4}	1 pc. (330 Ω)
		AT32-KES ^{*5}	1 pc. (2 kΩ)
	Contact discharge tip	CT31-KES ^{*4}	1 pc. (330 Ω) with protective cap
		CT32-KES ^{*5}	1 pc. (2 kΩ) with protective cap
	Sphere discharge tip ^{*5}	ST31-KES	1 pc. (330 Ω)
		ST32-KES	1 pc. (2 kΩ)
	CR unit ^{*5}	CR32-KES	1 pc. (330 pF, 330 Ω)
		CR33-KES	1 pc. (150 pF, 2 kΩ)
		CR34-KES	1 pc. (330 pF, 2 kΩ)
User's manual		1 copy	
CD-ROM		1 pc.	

*1. The high-voltage cable is approximately 2.5 m.

*2. Including the high-voltage cable.

*3. The CR unit (150 pF, 330 Ω, complies with the IEC 61000-4-2 standard) is built into the discharge gun.

*4. Complies with the IEC 61000-4-2 standard.

*5. Complies with the ISO 10605 standard and is included with IEC/ISO-compliant model.

Outline drawing

Discharge gun outline drawing

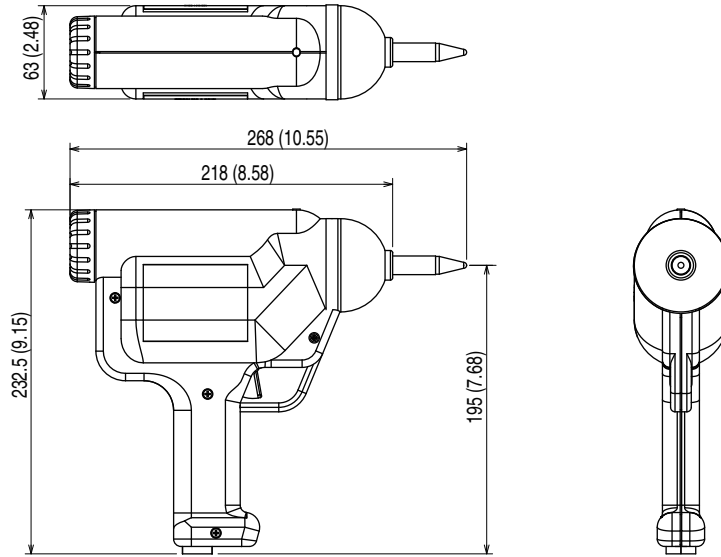

Unit: mm (inch)

Main unit outline drawing

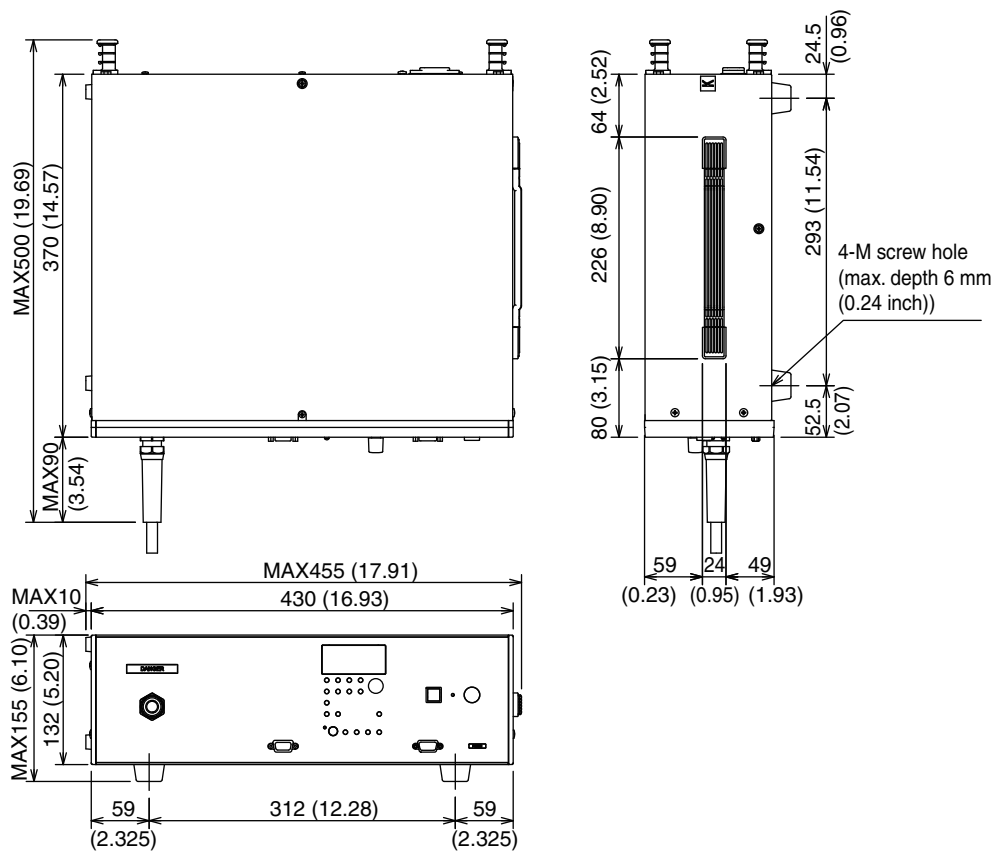

Unit: mm (inch)



Appendix

- A How Discharging Works
- B List of Default Settings
- C Troubleshooting
- D Maintenance
- E About Errors

A How Discharging Works

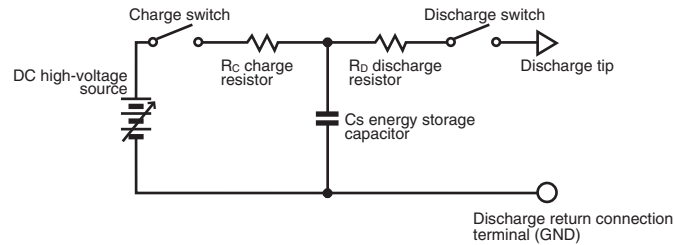

The charge and discharge switches open and close alternately. When the charge switch is closed, the DC high-voltage source passes through R_c and charges C_s . When charging is complete, the charge switch opens and the discharge switch closes. The electrical charge stored in C_s is discharged to the EUT through R_d .

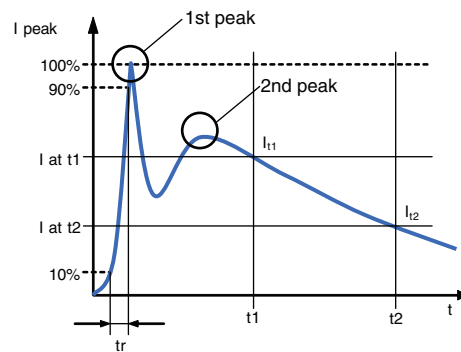

The discharge waveform is defined by the current and is determined by the distribution capacitance^{*1} (C_d) and the characteristics of the discharge switch. This distribution capacitance primarily affects the first peak. $C_d + C_s$ primarily affects the second and subsequent peaks.

The length and shape of the discharge return cable that is connected to the discharge return connection terminal (GND) also affect the waveform characteristics.

See p. 102

The current waveform generated from the electrostatic testing device is required to be observed properly complied with the measuring environment standard (described in the IEC 61000-4-2 standard, ISO 10605 standard).

*1. The distribution capacitance (C_d) is formed between the generator and the EUT, between the generator and the ground reference plane, and between the generator and the coupling planes. This capacitance is distributed over the entire system and varies depending on the present conditions. Thus, it cannot be shown in the circuit diagram.

B List of Default Settings

Initializing the KES4022A

There are two ways to initialize the KES4022A. You can either initialize all of the settings, or you can initialize all of the settings except for the memory contents and baud rate. Use the appropriate initialization method.

■ Initializing all settings except the memory contents and the baud rate



While holding down SHIFT key, turn the POWER switch on. The KES4022A displays the firmware version and then displays “ini.” Then, all settings except the memory contents and baud rate are set to their factory default values.

■ Initializing all settings

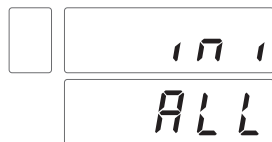

While holding down SHIFT, RECALL, and STORE keys, turn the POWER switch on. After displaying the firmware version, the KES4022A displays “ini” in the upper display and “ALL” in the lower display. Then, the KES4022A is initialized.

Default values

App.

	Item	Default value
Manual operation	Test voltage	2.00 kV
	Number of discharges	10
	Discharge interval	1.0 s
	Polarity	Positive
	Discharge mode	C: Contact discharge
	Trigger	G: Discharge gun
IEC test level operation	Test level	2
	Number of discharges	10
	Discharge interval	1.0 s
	Discharge points	1
	Polarity	P-n: Start with a positive voltage and switch the polarity for each test
	Discharge mode	C: Contact discharge
	Trigger	G: Discharge gun
	Wait feature	oFF

	Item	Default value
Step operation	Start voltage	2.00 kV
	Stop voltage	4.00 kV
	Step voltage	0.50 kV
	Number of discharges	10
	Discharge interval	1.0 s
	Discharge points	1
	Polarity	P-n: Start with a positive voltage and switch the polarity for each test
	Discharge mode	C: Contact discharge
	Trigger	G: Discharge gun
	Wait feature	oFF
Sequence operation *1	Test voltage	0.01 kV
	Number of discharges	10
	Discharge interval	1.0 s
	Discharge points	1
	Polarity	Positive
	Discharge mode	C: Contact discharge
	Trigger	G: Discharge gun
	Wait feature	oFF
CONFIG settings	RS232C baud rate	9600 bps
	Buzzer volume when a test ends	30
	Buzzer volume when an alarm occurs	30
	Panel brightness	7
	Discharge counter mode (common)	uP
	Gun trigger mode (common)	PuSH: Performs testing while the trigger switch is held down
	Power-on panel settings	init: Factory default settings
	Memory protection	on

*1. Only step number 1 is valid.

Default memory settings

There are 20 panel memory locations for each operation, with 80 memory locations total. In the tables containing default memory settings, the following notations are used.

- C: Indicates Contact Discharge mode.
- A Indicates Air Discharge mode.
- PoS: Indicates that only positive voltage will be tested.
- nEG: Indicates that only negative voltage will be tested.
- P-n: Indicates that testing will start with a positive voltage and that the polarity will switch for each step.
- n-P: Indicates that testing will start with a negative voltage and that the polarity will switch for each step.
- PA-nA: Indicates that all positive voltages will be tested and then all negative voltages will be tested.
- nA-PA: Indicates that all negative voltages will be tested and then all positive voltages will be tested.
- oFF: Wait feature off

Manual operation and sequence operation

The default settings of each operation are set in memory numbers 1 to 20. Only step 1 is set in sequence operation.

IEC test level operation

Except for the items in the following figure, the default settings of IEC test level operation are set in memory numbers 1 to 20.

App.

Item	Memory number									
	1	2	3	4	5	6	7	8	9	10 to 20
Test level	2	2	2	3	3	3	3	4	4	1
Discharge mode	C	C	C	A	A	A	C	C	A	C
Polarity	P-n	Pos	nEG	P-n	Pos	Neg	P-n	P-n	P-n	P-n

Step operation

Except for the items in the following figure, the default step test settings are set in memory numbers 1 to 20.

Item	Memory number						
	1	2	3	4	5	6	7 to 20
Start voltage (kV)	2.00	2.00	-2.00	2.00	2.00	-2.00	0.01
Stop voltage (kV)	-4.00	4.00	-4.00	-8.00	-8.00	-8.00	0.01
Step voltage (kV)	0.50	0.50	0.50	0.50	0.50	0.50	0.01
Polarity	P-n	Pos	nEG	P-n	Pos	nEG	Pos

C Troubleshooting

This appendix explains troubleshooting measures for typical problems. Check whether or not your problem corresponds to any of the items listed below. In some cases, the problem can be solved easily.

 p. 95

If your problem does not correspond to any of the listed items, we recommend that you initialize the KES4022A to its factory default settings. If you carry out the corrective action but the situation does not improve, contact your Kikusui distributor or agent.

The power does not turn on.

Problem	Items to check and corrective actions	
The KES4022A does not operate even when the POWER switch is turned on.	<ul style="list-style-type: none"> Is the power cord disconnected? Is the power cord broken? 	p. 24
	Is the rated line voltage being applied to the KES4022A? Use the KES4022A at the nominal input rating.	p. 24

The KES4022A cannot be configured.

Problem	Items to check and corrective actions	
Keys do not work.	Keys that cannot be used are disabled.	—
Unable to store to memory.	Is memory protection on? Use CONFIG setting 8 to turn memory protection off.	p. 38
Unable to configure sequence operation	Press EDIT (SHIFT+OPERATION) to switch to the sequence editing screen, and then set the sequence operation conditions.	p. 55
The buzzer sounds.	Securely fasten the CR unit cap.	p. 21
“Batt Err” is displayed.	When the backup battery is low, the KES4022A cannot store test conditions, etc. Press CLEAR to clear the error. The panel settings will be initialized, and you will be able to use the KES4022A. To replace the backup battery, contact your Kikusui distributor or agent.	p. 103

Unable to perform testing properly

Problem	Items to check and corrective actions	
Cannot start testing.	Is the trigger setting appropriate? Check the trigger setting.	p. 36
	Is the DANGER indicator illuminated? Press HIGH VOLTAGE ON to switch the KES4022A to standby.	p. 47

D Maintenance

Cleaning



WARNING

To avoid electric shock, be sure to turn the **POWER** switch off and remove the power cord plug from the outlet.



CAUTION

Do not use volatile chemicals such as benzene or thinner. They may discolor the surface, erase printed characters, cloud the display, and so on.

If the main unit or discharge gun needs cleaning, gently wipe it using a soft cloth with water-diluted neutral detergent.

- To maintain good insulation characteristics, be sure to periodically clean the red discharge gun cup.
- After cleaning, allow it to dry completely before use.

Inspection

Check the cables periodically for tears and breaks.



WARNING

To avoid electric shock or fire, immediately stop using the KES4022A if you find breaks or tears in the insulation.

To purchase accessories or options, contact your Kikusui agent or distributor.

■ Power cord

Check that there are no tears in the insulation and that the plug is not wobbly or broken.

■ High-voltage section of the discharge gun

Check that the discharge gun is not cracked and that its screws are not loose.

■ High-voltage cables (including the discharge return cable)

Check that the insulation is not dirty or damaged and that the high-voltage cables are not broken. Check that the cable insulation at the HIGH VOLTAGE OUTPUT terminal and at the root of the discharge gun is not misaligned or loose.

You can determine whether or not the high-voltage cable is broken by performing an air discharge test.

 See p. 50

1 In the air discharge testing procedure, set the test voltage to 2 kV.

2 Bring the air discharge tip close to the discharge return cable's terminal.

3 Check that discharge occurs in this process.

If it does, the cable is not broken.

If it does not, the cable may be broken. Stop using the KES4022A immediately, and contact your Kikusui distributor or agent to have the cable repaired.

Overhaul

For internal inspection and cleaning, we recommend that the KES4022A be overhauled periodically. We recommend that the KES4022A be overhauled (inspected and cleaned) periodically by a Kikusui service engineer.

NOTE

The high-voltage switch in the discharge gun that is used to generate discharges wears out over time. The high-voltage switch will wear out rapidly if you use the KES4022A:

With a test voltage that exceeds the IEC test level.

With the discharge interval set to less than 1 second.

In conditions other than those specified for IEC or ISO standard testing.

In combination with the optional C unit and discharge resistor.

The high-voltage waveform output switch inside the discharge gun may break after numerous discharges or intensive use. If you notice strange switch operation sounds or changes in the output waveform, we recommend that you get the KES4022A inspected and calibrated.

Maintenance parts

The following maintains parts are available.

NOTE

If you replace the CR unit that is supplied with the standard product with another unit, the KES4022A needs to be calibrated.

- Contact discharge tip (CT31-KES, CT32-KES)
- Air discharge tip (AT31-KES, AT32-KES)
- Sphere discharge tip (ST31-KES, ST32-KES)
- CR unit 150 pF/330 Ω (CR31-KES)
- CR unit 330 pF/330 Ω (CR32-KES)
- CR unit 150 pF/2 k Ω (CR33-KES)
- CR unit 330 pF/2 k Ω (CR34-KES)

For information about other options, contact your Kikusui agent or distributor.

Calibration

The KES4022A is calibrated before shipment. To maintain long-term performance, we recommend periodic calibration. To have your KES4022A calibrated, contact your Kikusui distributor or agent.

To change an IEC-compliant KES4022A to an IEC/ISO-compliant model, you must purchase options and have the KES4022A calibrated.

The current waveform generated from the electrostatic testing device is required to be observed properly complied with the measuring environment standard (described in the IEC 61000-4-2 standard, ISO 10605 standard).

**WARNING**

To avoid electric shock, do not calibrate the KES4022A yourself. Contact your Kikusui distributor or agent.

■ IEC-compliant model

The KES4022A calibration is performed on the combination of the main unit, discharge gun, standard CR unit (CR31-KES), and contact discharge tip (CT31-KES).

If you have multiple CR units, make sure that the standard CR unit is installed in the discharge gun before requesting calibration.

Other combinations that do not include the standard CR unit (CR31-KES) do not meet the IEC 61000-4-2 standard requirements. Therefore, they will not be calibrated. However, the main unit can be calibrated for performance.

■ IEC/ISO-compliant model

The KES4022A calibration is performed on the combination of the main unit, discharge gun, standard CR unit (CR31-KES, CR32-KES, CR33-KES, CR34-KES), and discharge tip (CT31-KES, CT32-KES).

Proper measuring environment

This section uses an example to explain the proper measuring environment that is based on the IEC 61000-4-2 standard.

For the detail of IEC standard, please refer to the IEC61000-4-2 Ed.2.0 2008-12. For the detail of ISO standard, please refer to the ISO 10605 Ed.2.0 2008-07.

■ Observing the waveform of discharge current

The following equipments are required for observing the waveform of discharge current.

- Coaxial current target (will be provided through a special order)
- Faraday cage (Front area: A square with each side 1.2 m in length or greater; will be provided through a special order)
- Oscilloscope (Required higher than 2 GHz (ISO standard: higher than 1 GHz) of the frequency bandwidth)

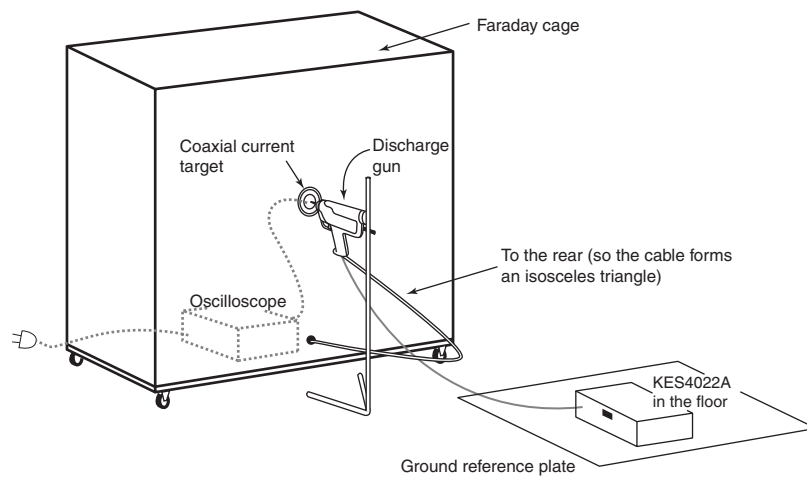

The standards specify that triggers be set to 10% of the first peak current value. Depending on the oscilloscope that is used, triggers may occur again on signals that are not the main discharge (such as charge noise). If these unwanted triggers occur, use the oscilloscope's hold-off function (set the hold-off time to approximately 40 ms), and observe the signal.

Confirm the output voltage.

The IEC 61000-4-2 standard is required for the following output voltage.

At contact discharge: 8 kV or higher

At air discharge: 15 kV or higher

For measuring of the output voltage, the custom-designed voltage measurement device (Model SPEC80562 : manufactured by Kikusui) is required.

The standards specify that measurements be performed at the discharge gun's discharge tip. However, the KES4022A is designed to prioritize the single discharges that are required by the standards, so measurements cannot be performed at the discharge tip.

The following describes the outline of the electrostatic testing device and an example of measuring environment for the output voltage using the custom-designed voltage measurement device Model SPEC80562.

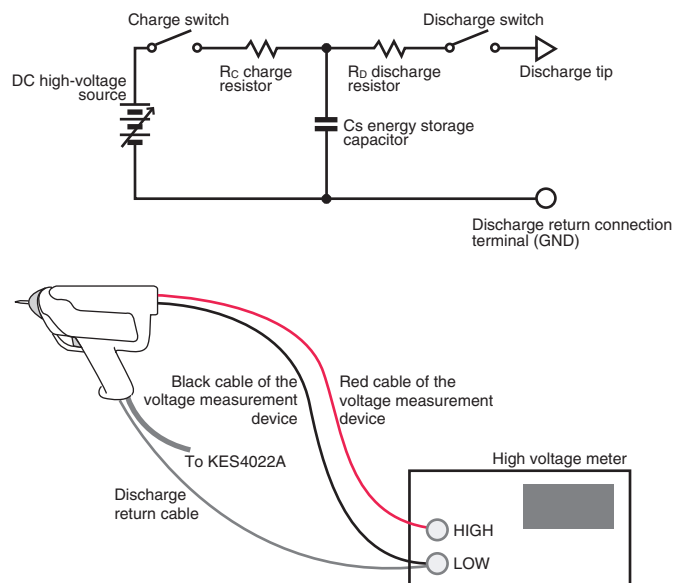

App.

Backup battery replacement

The KES4022A uses a lithium battery for memory backup.

When the battery is low, the KES4022A cannot store test conditions, etc. (Battery life varies depending on the environment.)

We recommend that you save the contents of the memory in the application software.

As a guideline, we recommend that the battery be replaced once every three years. You can also have the KES4022A inspected and cleaned at the same time.

You must open the cover to replace the backup battery. For battery replacement, contact your Kikusui distributor or agent.

See p. 40

E About Errors

The KES4022A displays errors when it is used improperly, when it suspects a malfunction, or when there is a possibility that it will be damaged. When an error occurs, the upper display shows the error type, and the lower display shows “Err.”

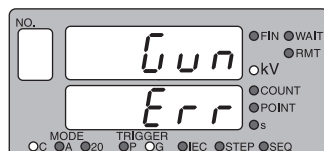

Example of a discharge gun error

Error type	Description and corrective action	See
CAL (<input type="text" value="CAL"/>)	An error occurred in the calibration data. You cannot clear this error. Contact your Kikusui distributor or agent to get the KES4022A repaired.	—
bArr (<input type="text" value="bArr"/>)	The backup battery is low. Press CLEAR to clear the error. The panel settings will be initialized, and you will be able to use the KES4022A. To replace the backup battery, contact your Kikusui distributor or agent.	p. 103
VoLt (<input type="text" value="VoLt"/>)	An error occurred in the output voltage. You cannot clear this error. Contact your Kikusui distributor or agent to get the KES4022A repaired.	—
Gun (<input type="text" value="Gun"/>)	The discharge gun's CR unit cap is off. Put the cap on securely, and then press CLEAR to clear the error.	p. 21

If the corrective actions that you take do not clear the error, the KES4022A may be broken. Stop using it immediately, and contact your Kikusui agent or distributor for help with the error.

INDEX

A	
accessories	18
Air Discharge mode	29
application software	70
communication with the KES4022A	86
installation	71
saving and loading	83
auto operation	28
B	
backup battery replacement	103
buzzer	48
buzzer volume	39
C	
calibration	101
cleaning	99
Communication Interface Manual	70
communication ports	82
Communication with the KES4022A	86
CONFIG settings	38
Contact Discharge mode	29
CR unit, checking and replacing	21
D	
default settings	95
direct recall	41
discharge chip, attachment	22
discharge counter mode	39
Discharge current waveform	88
discharge gun	10
CR unit, checking and replacing	21
discharge chip, attachment	22
discharge return cable, connection	23
preliminary inspection	23
discharge gun stand	46
discharge interval, setting of	35
discharge mode	29
discharge points, setting	36
discharge return cable, connection	23
discharge test	28
discharges, setting the number of	34
discharging, process	94
display brightness	39
E	
emergency, steps to be taken in	26
errors	104
F	
firmware version	2, 25
first peak	94
front panel	8
G	
gun trigger mode	39
H	
High-voltage discharge switch	43
I	
IEC test level operation	28
IEC Test Level sheet	76
IEC61000-4-2 standard, voltage	31
inspection	99
K	
KES4022A_SAMPLE_APPLICATION_SOFTWARE.xls	70
M	
maintenance parts	100
manual operation	28
Manual sheet	74
memory	
protection	39
recall	41
storage	40
N	
names and functions	
discharge gun	10
front panel	8
rear panel	10
O	
operating humidity range	19
operating temperature range	19
options	13
outline drawing	92
P	
panel settings	
power-on	39
polarity, setting	33
power cord	24
POWER switch	25
protocol	72
R	
rear panel	10

recall	41
resolution	43
RS232C	
baud rate	39
connection	72
protocol	72

S

second peak	94
Sequence operation	28
sequence operation	
examples of creating	62
starting	66
Sequence sheet	80
Setting sheet	82
single operation	28
specifications	87
standby	47
step	
copying	59
creating	56
deleting	60
editing	58
moving	60
step operation	28
voltage, setting	32
Step sheet	78
storage	40
Storage humidity range	19
storage temperature range	19

T

test	
air discharge testing	50
contact discharge testing	50
display	49
pause	52
post-testing procedures	52
preparation	46
starting	48
TOTAL COUNT	43
trigger	36
troubleshooting	98

V

version	2, 25
voltage, setting	30
step operation	32

W

wait feature	37
warm-up time	88