



Advanced Test Equipment Rentals
www.atecorp.com 800-404-ATEC (2832)



MD 103 ESD TARGET SET

USER MANUAL

601-266B

TESE
Advanced Test Solutions for EMC

MD 103 ESD TARGET SET
USER MANUAL

CONTENTS

1	Safety terms and symbols	5
2	The ESD target set	6
3	Handling of the target set	7
4	Requirements by a new draft standard	9
5	Using the target	10
6	Relation between voltage and real current flowing	12
7	Preparing the target for calibration with INA 103 adapter	13
8	Calibrating the target using INA 103 option	16
9	Determining the low frequency transfer impedance	19
10	Technical specifications MD 103	20
11	Ordering information	21
12	Addresses	22

1 SAFETY TERMS AND SYMBOLS



Please take note of the following explanations of the symbols used in order to achieve the optimum benefit from this manual and to ensure safety during operation of the equipment.

The following symbol draws your attention to a circumstance where non-observation of the warning could lead to inconvenience or impairment in the performance.

Example:



Caution statements identify conditions or practices that could result in damage to this product or other property.



An ESD target is a shunt for measuring the ESD discharge current flowing in a measurement circuit. The target is intended to emulate a discharge into a perfect ground plane. To minimize the error caused by any difference between a perfect conducting plane and the input impedance of the target, a 2.1 Ω limit has been set for the input impedance.

The impedance of the MD 103 target is 1.03 Ω . An even smaller impedance value would generate a very small output signal which would be subject to errors due to coupling into cables and oscilloscope.

A very important parameter of the target is the DC transfer impedance Z_{SYS} , this is the ratio between the voltage measured on the scope and the real current flowing through the target. For the exact value, please refer to the calibration certificate.

3 HANDLING OF THE TARGET SET



The target consists of the complete set with cable, attenuator and discharge part (target) like the pictures below.



The MD 103 is a high precision device, please handle with care.



Leave the ESD target with the attenuator and the cable together and do not disassemble the set in parts, since the whole coupling path has been calibrated in one piece.

MD 103 parts identification:



- Carry case
- User manual
- Calibration certificate
- ESD target
- Attenuator 20 dB
- Coax cable Sucoflex

The carry case has extra space for the calibration adapter INA 103, the special screw tool and an adapter to connect to an analyzer or to a scope.

4 REQUIREMENTS BY A NEW DRAFT STANDARD



In order to improve the reproducibility between calibration laboratories, the frequency characteristic of the target has now been defined in a new draft standard submitted by ANSI and IEC.

The new draft of the standard sets limits for the insertion loss of the whole measurement chain including the target itself, cables and any attenuator present. The variation in the insertion loss of the chain may not exceed:

- +/- 0.3 dB up to 1 GHz
- +/- 1 dB between 1 GHz and 4 GHz

The MD 103 shows an almost flat frequency response up to 4 GHz. The next figure shows the insertion loss of the MD 103 (solid line) and the permitted tolerances (dotted lines).

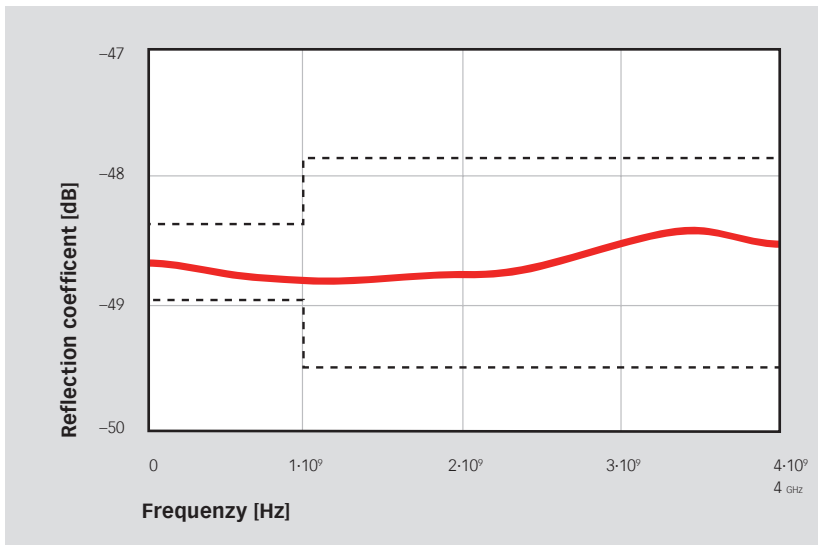

5 USING THE TARGET



The MD 103 target comes fully assembled ready to be screwed into the reference plane. The plane should be at least 1.2 x 1.2 m in size and forms part of a HF-tight enclosure for cables, attenuators and the oscilloscope.

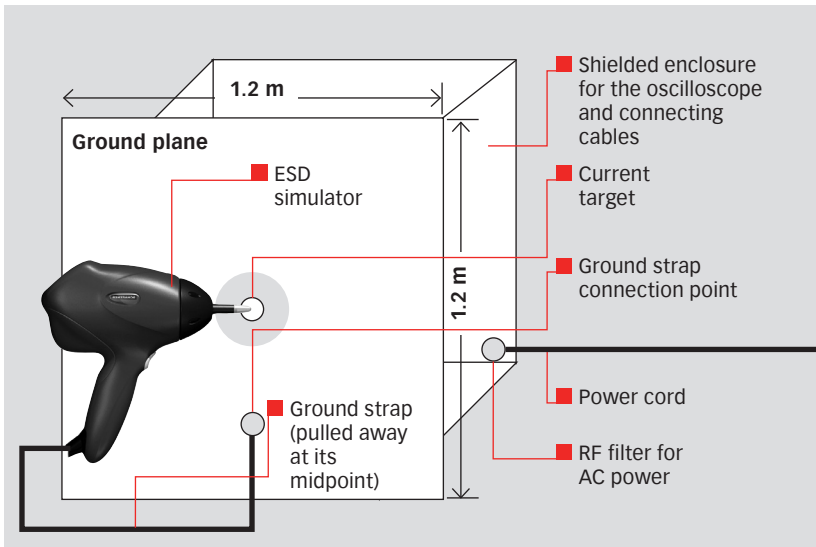

Typical arrangement for calibration of ESD simulator performance.

This is the drilling template for the reference plane.

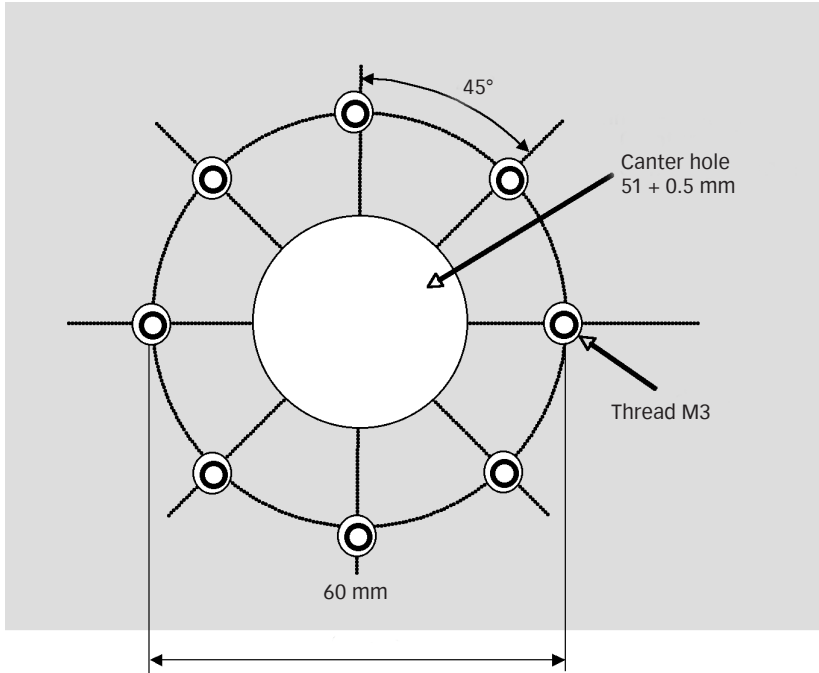

Schematically, the measurement chain looks as follows.

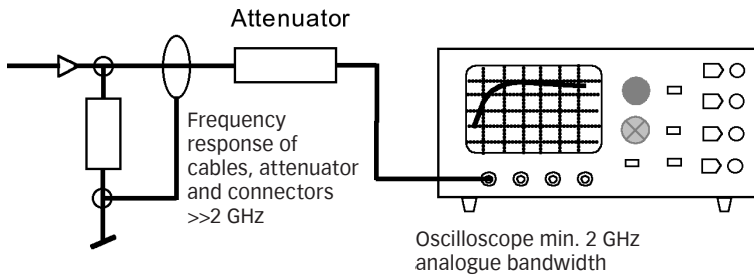

6 RELATION BETWEEN VOLTAGE AND REAL CURRENT FLOWING



To get the peak current, a suitable scope will be needed as well as the exact transfer impedance ratio value Z_{SYS} , which is found in the calibration certificate. If the target is mounted, and the measuring setup conforms to the standard recommendations, then following calculation has to be made to get the current.

$$\frac{\text{Measured peak voltage [V]}}{\text{Low frequency transfer impedance ratio } [\Omega]} = \text{Pulse peak current [A]}$$

Numeric example:

Set the ESD simulator to 8 kV and discharge directly to the target so the peak voltage on the scope in the 50 Ω system is 2.89 V. The transfer impedance for the MD 103 is $Z_{\text{SYS}} = 0.098 \Omega$ or $10.3 \frac{1}{\Omega}$ [Siemens].

$$\frac{2.89 \text{ V}}{0.098} = \underline{\underline{29.49 \text{ A}}}$$

So the calculated peak current flow is 29.49 A by 8 kV ESD voltage. To fulfill the IEC/EN 61000-4-2 recommendation the 30 ns and the 60 ns point needs to be measured and calculated, too.

7 PREPARING THE TARGET FOR CALIBRATION WITH INA 103 ADAPTER



The optional INA 103 is needed if the target has to be calibrated. The INA 103 calibration adapter can be placed in the MD 103 carry case.



For calibration, unscrew the center contact bolt with the special screw tool and remove it carefully.

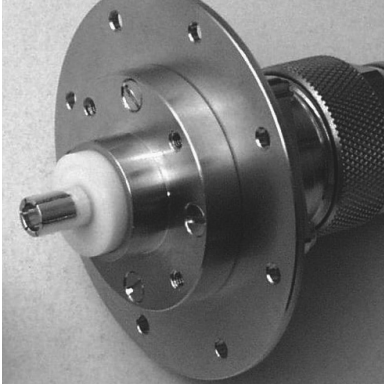

Screw from the center pin the screw bolt into the target, add the isolator and screw the connector pin into the screw bolt.

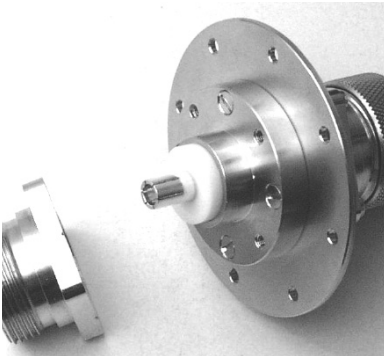

Screw the connector socket onto the calibration ring.



The assembled target with the calibration adapter is now ready to be used for calibration.

8 CALIBRATING THE TARGET USING INA 103 OPTION



According to the new draft standard, the insertion loss of the target should be measured with a network analyzer. The network analyzer has two coaxial connection ports. For insertion loss measurements on the target an adapter is necessary, which provides a matched low reflection from the front side of the target to the coaxial connector of the network analyzer.

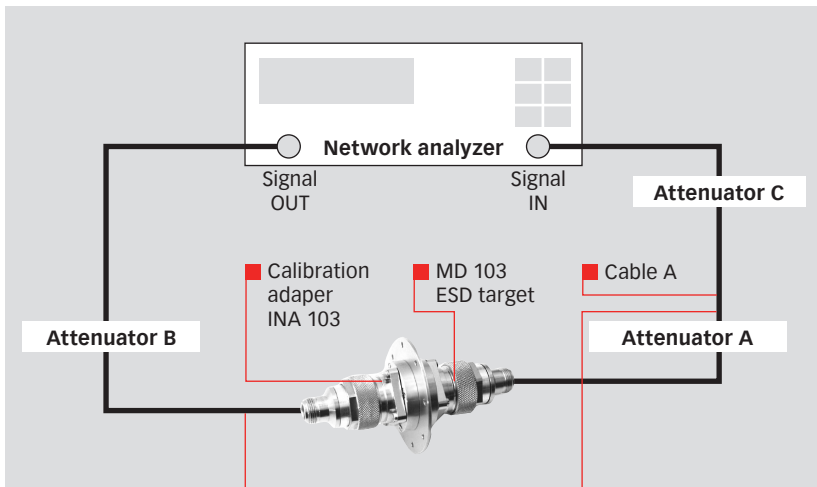

■ **Calibrate the network analyzer at this point**

The ESD current target, attenuator A and cable A are the target-attenuator-cable chain which is calibrated using this setup. Attenuator B and C may not be needed.

For a proper connection to an analyzer or scope an adaptor may be needed and can be placed into the spare place of the MD 103 carry case.

MD 103 ESD target set

In order to minimize the influence of the adapter on the measurements, frequency parameters of the adapter are specified in the draft. These parameters are verified for two adapters connected face to face. They must be as follows:

Reflection coefficient:

- < -30 dB up to 1 GHz
- < -20 dB between 1 GHz and 4 GHz

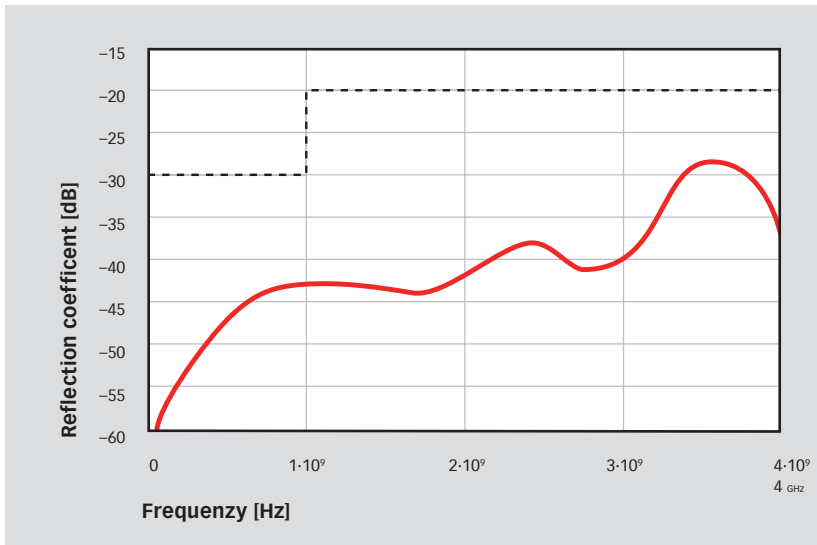

Reflection coefficient of two adapters for the MD 103 placed face to face (solid line) and the permitted tolerance (dotted line).

18 Insertion loss must be better than -0.3 dB up to 4 GHz.

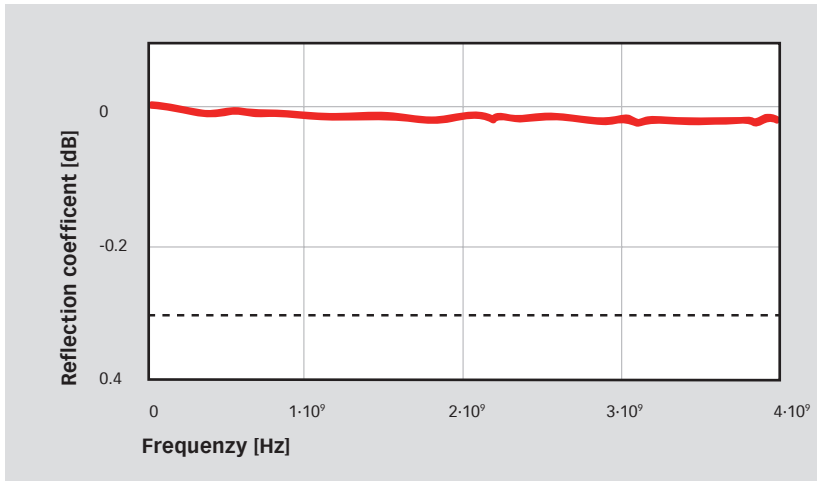

Insertion loss of two adapters for the MD 103 placed face to face (solid line) and the permitted tolerance (dotted line).

Moreover the characteristic impedance of the adapter must be within the limit of $50 \Omega \pm 2\%$ (i.e. it must be between 49Ω and 51Ω). The adapter is an assembly of coaxial cylinders with a diameter for the outer cylinder $D = 16 \text{ mm} \pm 0.02 \text{ mm}$ and a diameter of the inner cylinder $d = 7 \text{ mm} \pm 0.02 \text{ mm}$. The formula for calculating the characteristic impedance is as follows:

$$Z_w = 60 \cdot \ln \frac{D}{d}$$

The calculated characteristic impedance of the adapter is therefore 49.6Ω . Taking into account the tolerances, this impedance is no greater than 49.35Ω and no less than 49.84Ω .

Another significant element of the adapter is the professional connector type N-7/16 (Huber Suhner). The producer of the connector guarantees $50 \Omega \pm 2\%$ characteristic impedance up to 7.5 GHz. The requirement concerning the characteristic impedance of the adapter for the MD 103 is hence fulfilled.

MD 103 ESD target set

9 DETERMINING THE LOW FREQUENCY TRANSFER IMPEDANCE



The low frequency transfer impedance of a target-attenuator-cable chain is defined as the ratio between the current injected at the front face of the target and the voltage across a precision 50 Ω load at the output end of the cable.

The circuit diagram for measuring the low frequency transfer impedance looks as follows:

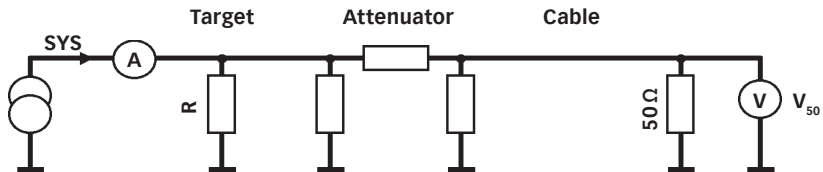

The low frequency transfer impedance can be determined by:

- Injecting a DC or LF current I_{SYS} of approx. 1 A into the front face of the target.
- Measuring the voltage V_{50} across the precision 50 Ω.
- Calculating the transfer impedance as follows:

$$Z_w = \frac{D_{50}}{I_{SYS}}$$

10 TECHNICAL SPECIFICATIONS

MD 103



Insertion loss (S21 parameter):	< -48.3 dB DC to 4 GHz
Average low frequency transfer impedance:	ZSYS = 0.098 Ω
Inner target diameter:	7 mm
Impedance:	1.03 Ω (SMD design)
Calibration ESD pulse amplitude:	1/2/4/8/15 kV
Max. ESD pulse amplitude:	30 kV
Calibration adapter reflection coefficient:	< -40 dB up to 1 GHz < -25 dB between 1 GHz and 4 GHz
Target parts:	Gold plated
Cable connectors:	Type N

11 ORDERING INFORMATION



MD 103 ESD calibration target set

Including:

- Carry case
- User manual
- Calibration certificate
- ESD target
- Attenuator 20 dB
- Coax cable Sucoflex



Options:

- INA 103
Calibration adaptor
with special screw
tool



Headquarters

Teseq AG

4542 Luterbach, Switzerland

T +41 32 681 40 40

F +41 32 681 40 48

sales@teseq.com

www.teseq.com

Manufacturer

Teseq AG

4542 Luterbach, Switzerland

T +41 32 681 40 40

F +41 32 681 40 48

sales@teseq.com

China

Teseq Company Limited

T +86 10 8460 8080

F +86 10 8460 8078

chinasales@teseq.com

France

Teseq Sarl

T +33 1 39 47 42 21

F +33 1 39 47 40 92

francesales@teseq.com

Germany

Teseq GmbH

T +49 30 5659 8835

F +49 30 5659 8834

desales@teseq.com

Japan

Teseq K.K.

T +81 3 5725 9460

F +81 3 5725 9461

japansales@teseq.com

Singapore

Teseq Pte Ltd.

T +65 6846 2488

F +65 6841 4282

singaporesales@teseq.com

Switzerland

Teseq AG

T +41 32 681 40 50

F +41 32 681 40 48

sales@teseq.com

Taiwan

Teseq Ltd.

T +886 2 2917 8080

F +886 2 2917 2626

taiwansales@teseq.com

UK

Teseq Ltd.

T +44 845 074 0660

F +44 845 074 0656

uksales@teseq.com

USA

Teseq Inc.

T +1 732 417 0501

F +1 732 417 0511

Toll free +1 888 417 0501

usasales@teseq.com

© December 2010 Teseq®

Specifications subject to change without notice. Teseq® is an ISO-registered company. Its products are designed and manufactured under the strict quality and environmental requirements of the ISO 9001. This document has been carefully checked. However, Teseq® does not assume any liability for errors or inaccuracies.

To find your local partner within Teseq®'s global network, please go to www.teseq.com