



INSTRUCTION MANUAL

W/I AUTO TESTER

MODEL TOS8850

4 Edition

WARNINGS against **HIGH VOLTAGE**

- o This tester generates high voltage.*
- o Any incorrect handling may cause death.*
- o Read Section 3 "WARNINGS" in this manual to prevent accident.*
- o This manual should be placed within the reach of the operator so that he may read it whenever necessary.*

KIKUSUI ELECTRONICS CORPORATION
(KIKUSUI PART NO. Z1-211-220)

M-92072

— To supervisor in charge of operation —

- (1) *If the operator does not read the language used in this manual, translate the manual into appropriate language.*
- (2) *Help the operator in understanding this manual before operation.*
- (3) *Keep this manual near the tester for easy access of the operator.*

— Receiving inspection —

Prior to the shipment from our factory, the tester has been subjected to electric- and mechanical-testing and guaranteed of satisfactory quality and performance. Nevertheless, you are kindly requested to make an acceptance inspection to see if the tester has any in-transit damage. Should there be any, please inform our local dealer of such a damage.

— For your own safety (How to avoid electrification) —

(1) *While the tester is generating the output, do not touch the following areas, or else, you will be electrified, and run the risk of death by electric shock.*

- *the output terminal*
- *the test lead-wire connected to the output terminal*
- *the Device Under Test (D.U.T.)*
- *any part of the tester, which is electrically connected to the output terminal, and*
- *the same part as above immediately after the output has been cut off. (in case of insulation resistance test)*

(2) *Also, electric shock or accident may arise in the following cases:*

- *the tester being operated without grounding.*
- *if the gloves for electrical job are not used.*
- *approach to any part connected to the output terminal while the power of the tester is turned on.*
- *the same action as above immediately after the power of tester has been turned off. (in case of insulation resistance test)*

= ATTENTION =

Pay attention to the following instructions and those warnings given in the Section 3 "WARNINGS" as well.

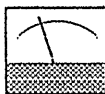

Swinging of the indicator means "high voltage warning"

Be sure to push the RESET button before changing the test condition

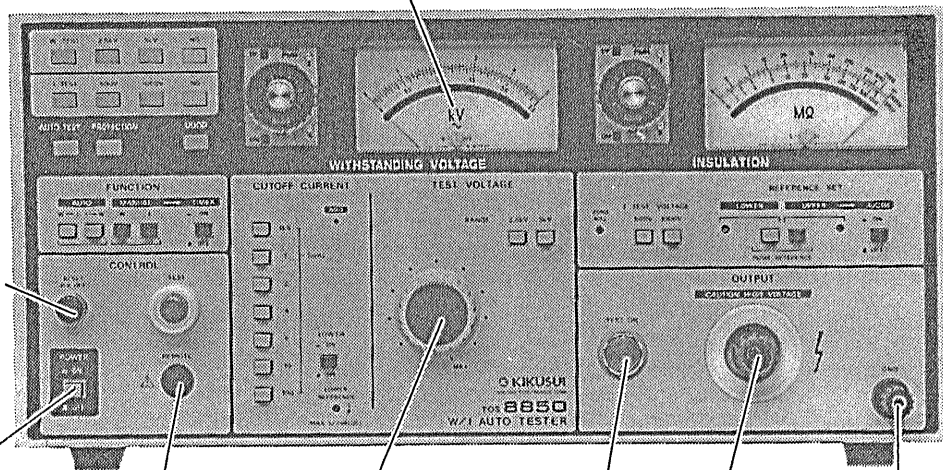

Turn on the POWER switch while the TEST VOLTAGE dial is at "0" position

TEST VOLTAGE dial should be at "0" position except during the testing.

High-voltage output terminal dangerous

Read Instruction Manual Page 37 before remote operation.

If the lamp comes on, it warns "high voltage"

Connect with the lead wire on GND side

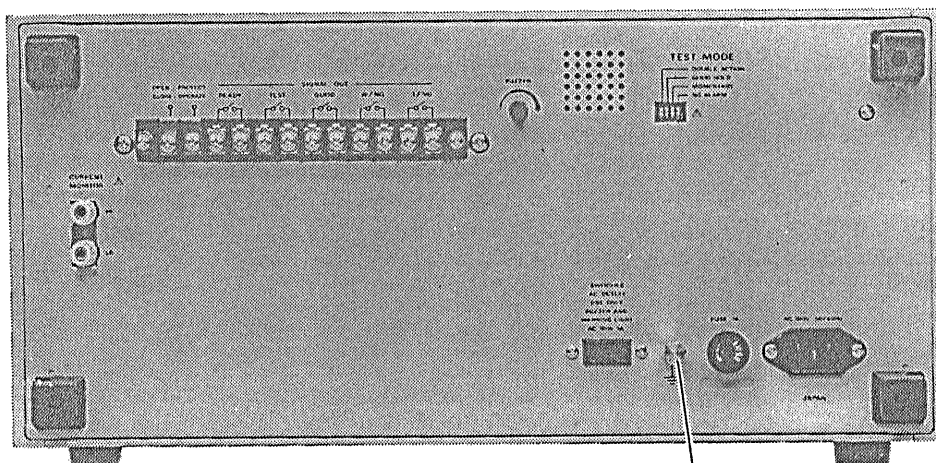

The rear-side of the tester casing and the protective grounding terminal shall be connected to the earth, using the applicable tool

895287

Power Requirements of this Product

Power requirements of this product have been changed and the relevant sections of the Operation Manual should be revised accordingly.

(Revision should be applied to items indicated by a check mark)

Input voltage

The input voltage of this product is _____ VAC,
and the voltage range is _____ to _____ VAC. Use the product within this range only.

Input fuse

The rating of this product's input fuse is _____ A, _____ VAC, and _____.

WARNING

- To avoid electrical shock, always disconnect the AC power cable or turn off the switch on the switchboard before attempting to check or replace the fuse.
- Use a fuse element having a shape, rating, and characteristics suitable for this product. The use of a fuse with a different rating or one that short circuits the fuse holder may result in fire, electric shock, or irreparable damage.

AC power cable

The product is provided with AC power cables described below. If the cable has no power plug, attach a power plug or crimp-style terminals to the cable in accordance with the wire colors specified in the drawing.

WARNING

- The attachment of a power plug or crimp-style terminals must be carried out by qualified personnel.

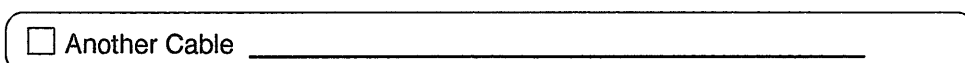
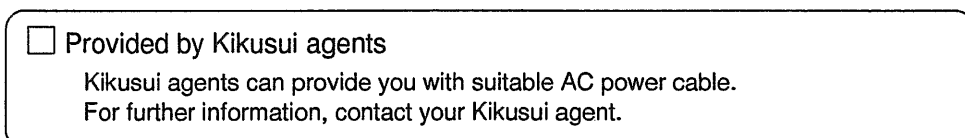
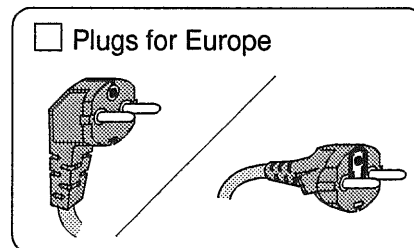
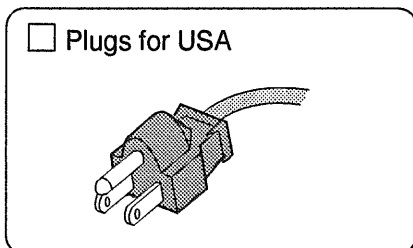
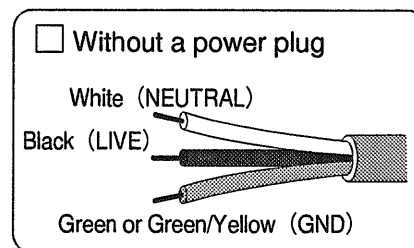
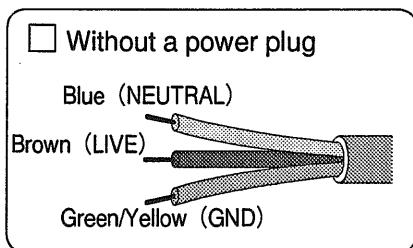

TABLE OF CONTENTS

	<u>PAGE</u>
1. GENERAL	1
2. SPECIFICATIONS	2
3. WARNINGS	10
4. OPERATION INSTRUCTIONS	18
4.1 Description of Front Panel	18
4.2 Description of Rear Panel	25
4.3 Operating Procedures	27
4.3.1 Procedure Before Test	27
4.3.2 Single Withstanding Voltage Test	27
4.3.3 Single Insulation Resistance Test	33
4.3.4 Automatic Test	36
4.3.5 Remote Control	37
4.3.6 Output Signals	41
4.3.7 Special Test Modes	46
4.3.8 Timer	48
5. OPERATING PRINCIPLE	49
5.1 Block Diagram	49
5.2 Descriptions of Individual Circuits	50
5.3 Zero-turn-on Switch	52
5.4 Waiting-time for Judgement in Insulation Resistance Test	53
6. MAINTENANCE	54
6.1 Cautions	54
6.2 Calibrations	54
7. OPTIONS	64

1 . GENERAL

Model TOS8850 W/I Auto Tester is a combination of an withstanding voltage tester and an insulation resistance tester, and it is capable of performing withstanding voltage test and insulation resistance test in one continuous process.

As for the withstanding voltage tester, the Tester can provide a maximum output voltage of 5 kV and an output wattage of 500 VA, and can be used for withstanding voltage test in compliance with JIS, UL, CSA, BS and other major electrical standards and ordinances. As for the insulation resistance tester, the Tester has two ranges of 500V/1000M Ω and 1000V/2000M Ω .

The Tester can perform a GO-NOGO judgement function when in either the withstanding voltage or insulation resistance test mode. A GO-NOGO judgement is with a window comparator type. When in withstanding voltage test, the Tester is capable of generating an NG judgement not only when the detected leakage current is greater than the high limit reference value preset on the front panel of the Tester but also when it is less than the low limit reference value (which is continuously adjustable down to one-half of the high limit reference value), thereby contributing to make GO-NOGO judgement including test of open circuiting of leadwires and imperfect contacting of connections.

The Tester is incorporated with a function to deliver signals representing the result of GO-NOGO judgement and the state of the Tester, and a remote control function. The signals namely are TEST ON, GOOD, READY, and NG alarm (contact signals). The Tester is incorporated also with a remote control function for test set/reset. These features can be utilized for automatic test with labor economization.

Its sequence circuit is designed with full attention to noise to prevent erroneous operation which could be caused by noise.

Although many safety features are incorporated in the Tester, a deadly accident may occur when the operator touches the device under test (D.U.T) or the probe.

Safety guards around D.U.T. should be considered for safe operation. Also, other precaution, which deemed necessary for the tester and the devices, shall be maintained under positive control.

2. SPECIFICATIONS

Withstanding Voltage Tester

Test Voltage

Applied voltage:	0 - 2.5 kV AC and 0 - 5 kV AC (two ranges)
Wattage rating:	500 VA (5 kV, 100mA, with 100 V line voltage) (See Note 1.)
Waveform:	AC line waveform
Voltage regulation:	Better than 20% (for maximum rated load to no load, with 100 V line voltage)
Switching:	With zero-start type switch

Output Voltmeter

Scales:	2.5 kV FS and 5 kV FS, two ranges linear scales
Class of meter:	JIS Class 1
Accuracy:	±3% FS or better
Indication:	Mean-value response, effective-value scale graduation

Judgement of Test Result

(GO-NOGO judgement. Output cutoff by leakage current detection)

Judgement:	<ul style="list-style-type: none">○ Window comparator system○ NG judgement when leakage current larger than high limit reference value is detected.○ NG judgement also when leakage current smaller than low limit reference value is detected.○ When NG judgement is made, output is cutoff and NG alarm is generated.○ If no NG judgement is made after preset period has elapsed, GOOD signal is generated.
------------	--

High limit reference value (CUTOFF CURRENT):	0.5/1/2/4/8/10/100 mA (7 values) By combinations of above values, a range of 0.5 - 25.5 mA can be covered in 0.5-mA steps.
--	---

Low limit reference value (LOWER REFERENCE): 0 to one-half of high limit reference values (continuously variable)

Accuracy of judgement: (See Note 2.)

- o $\pm 5\%$ of high limit reference value
- o $\pm 20\%$ of low limit reference value (one-half of high limit reference values at maximum counterclockwise). (Others are non-calibrated.)

Judging method: Absolute value of leakage current is integrated and compared with preset limit reference value

Calibration: Calibrated with rms value of sine wave, using a pure resistance load

No-load output voltage needed for detection: (See Note 3.)

- 2.5 kV range: Approx. 450 V when set at 100 mA
- 5 kV range: Approx. 550 V when set at 100 mA

Others

Test time: 0.2 seconds - 10 minutes (with 4-range timer)

Terminals: Terminals for monitoring of leakage current

Note 1: When the Tester is delivering its maximum rated current, its maximum rated continuous operation time is 30 minutes.

Note 2: The current which flows due to stray capacitances of the output circuit and leadwires causes an error. The overall accuracy of judgement is the above-mentioned accuracy of judgement plus a factor caused by this current. Typical values of this type of currents are shown in the next table. Note that, when a test is made with a high voltage and high sensitivity, the current which flows through the stray capacitances may become larger than the preset low limit reference value and low limit judgement may become unavailable.

895292

Output voltage	1 kV	2 kV	3 kV	4 kV	5 kV
Tester alone (without leadwires)	4 μ A	8 μ A	12 μ A	16 μ A	20 μ A
When 350-mm long leadwires are hung in air	6 μ A	12 μ A	18 μ A	24 μ A	30 μ A
When the accessory leadwires (TL01-TOS) are used	20 μ A	40 μ A	60 μ A	80 μ A	100 μ A

Note 3: When making an NG judgement test with the output terminals shorted, a certain level of no-load output voltage is needed due to the internal resistance of the output circuit. The voltages shown here are this type of output voltages.

Test Voltage Waveform: When an AC output voltage is applied to a capacitive load, it is possible that the voltage becomes higher than that when in the no-load state due to the capacitance of the load. Moreover, when the capacitance of the load is voltage dependent (typical examples are ceramic capacitors), the voltage waveform may be distorted. When the test voltage is 1.5 kV, however, effects caused by a capacitance of 1000 pF or less are negligible.

Insulation Resistance Tester

Measuring Voltages: 500 V and 1000 V (two ranges), DC, negative polarity

Effective Measurange Ranges

500 V range: 1 - 1000 M Ω

1000 V range: 2 - 2000 M Ω

Values at Center of Scale

500 V range: 20 M Ω

1000 V range: 50 M Ω

Accuracy

1st effective measuring range: $\pm 5\%$ of the indicated value

2nd effective measuring range: $\pm 10\%$ of the indicated value

Note 4: At 25°C $\pm 10^\circ\text{C}$

Note 5: The 1st effective measuring range is from 1/1000 to 1/2 of the maximum effective scale value. The 2nd effective measuring range is from the above to the maximum effective scale value.

Measuring terminal voltage

When output terminals are open: +5%, -0% of rated measuring voltage

When at center of scale: 95% or more of rated measuring voltage

Judgement of Test Result (GO-NOGO judgement)

- Judgement:
- Window comparator system (mutually indepent settings of high limit and low limit)
 - NG judgement when measured resistance is smaller than the low limit reference value.
 - NG judgement when measured resistance is larger than the high limit reference value.

- When NG judgement is made, output is cutoff and NG alarm is generated.
- If no NG judgement is made after preset period has elapsed, GOOD signal is generated.

Limit reference value setting range:

Low and high limit reference values can be set at any points within the effective measuring range of the Tester.

Accuracy of judgement

1st effective measuring : $\pm 10\%$ of set value range

2nd effective measuring : $\pm 15\%$ of set value range

Note 6: at $25^{\circ}\text{C} \pm 10^{\circ}\text{C}$

Waiting-time for judgement: Approx. 0.3 sec

Test Time: 0.5 second - 10 minutes (with 4-range timer)

Note 7: Since the Tester operates on an AC power line, measuring errors may be introduced if the device under test is connected to the AC line.

Overall Specifications

Types of Tests

1. AUTO W \rightarrow I: Withstanding voltage test first and insulation resistance test next
2. AUTO I \rightarrow W: Insulation resistance test first and withstanding voltage test next
3. MANUAL W: Withstanding voltage test alone
4. MANUAL I: Insulation resistance test alone

Remote Control

- Test/Reset control:
- Low active control
 - Input conditions
 - High level input voltage: 11 - 15 V
 - Low level input voltage: 0 - 4 V
 - Low level sweep out current: ≤ 2 mA
 - Input pulse width : 20 msec minimum

895295

Note 8: The input terminal is pulled up to +15V supply voltage by resistor. Opening of the input terminals is equivalent to a high level input.

Protection: Protection is effected when PROTECTION input terminal is made open (test is disabled).

Output Signals

TEST ON signal: Delivered during entire test-on period.
Make-contact signal and lamp

GOOD signal: Delivered when GOOD judgement is made, for approximately 50 msec. Make-contact signal, lamp and buzzer

W/NG alarm: Delivered continuously when NG judgement of withstanding voltage test is made. Make-contact signal, lamp and buzzer

I/NG alarm: Delivered continuously when NG judgement of insulation resistance test is made.
Make-contact signal, lamp and buzzer

READY signal: Delivered when in the READY state.
Make-contact signal

Note 9: (1) The rating of the signal contacts is 100 V AC, 1 A, or 30 V DC, 1 A.

(2) Loudness of the buzzer is adjustable with a knob in common for the GOOD signal and NG alarm.

Special Test Modes: Selectable with DIP switches at rear of the Tester

1. DOUBLE ACTION: Test starts only when the TEST button is pressed within approximately 0.5 seconds after pressing the RESET button.
2. GOOD HOLD: The GOOD state is held
3. MOMENTARY: Test is executed only during the period the TEST button is kept pressed.
4. NG ALARM: NG alarm and PROTECTION state cannot be reset by the remote-control RESET signal.

Ambient Temperature and Humidity

Specification range: 5 to 35°C (41 to 95°F), 20 to 80% RH
Operable range: 0 to 40°C (32 to 104°F), 20 to 80% RH
Storage range: -20 to 70°C (-4 to 158°F), 80% RH or less

EMC : Complied eith the follwing standards
European Community Requirements(89/336/EEC)
EN5501 Radiated Emissions Class A
Conducted Emissions Class A
EN50082-1
IEC801-2 Electro-static Discharge
IEC801-3 Radiated Susceptibility
IEC801-4 Fast Burst Transient

Under following conditions

- 1.Used HV test leadwires TL01-TOS.
- 2.No discharge in testing.

Power Requirements

Line voltage: 100 V \pm 10%, 50/60 Hz AC
(Can be factory-modified to nominal 110V, 115V, 120V, 200V, 220V, 230V and 240V.)

Power consumption

When no load (RESET state): 15 VA or less (Note 10)

When with rated load: Approx. 600 VA

Insulation resistance: 30M Ω or more, with 500 V DC

Withstanding voltage: 1000 V AC, 1 minute

Dimensions: 430 W \times 199 H \times 370 D mm
(16.93 W \times 7.83 H \times 14.57 D in.)

Including extrusions: 430 W \times 214 H \times 435 D mm
(16.93 W \times 8.43 H \times 17.13 D in.)

Weight: Approx. 24 kg (53 lb)
(approx. 28 kg (62 lb) when in Line Voltage modified)

Accessories:

- TL01-TOS High Voltage Test Leadwires, approx. 1.5 m (4.9 ft) long, 1 set
- 5P DIN plug (assembly type), 1
- Power cord set, 1
- AC Plug Adaptor, 1
(The AC Plug Adaptor is provided only for model versions for use within Japan.)
- "HIGH VOLTAGE DANGER" label, 1
- Instruction Manual, 1 copy

Note 10: Power consumption of the instrument modified to operate on an AC line voltage other than 100 V is as follows.

110/115/120 V : 25 VA or less
200/220/230/240 V: 45 VA or less

Options:

- RC01-TOS Remote Control Box
- RC02-TOS Remote Control Box
- HP01A-TOS High Voltage Test Probe, approx. 1.5 m(4.9 ft) long
- HP02A-TOS High Voltage Probe, approx. 3 m (9.8 ft)long
- TL02-TOS High Voltage Test Leadwires, approx. 3 m (9.8 ft) long
- PL01-TOS Warning Light Unit
- BZ01-TOS Buzzer Unit
- BH4M-TOS Rackmount Bracket (for JIS)
- BH5-TOS Rackmount Bracket (for EIA)

3. WARNINGS

The tester supplies high voltage up to 5kV to the outside connection. Thus any incorrect handling of the tester may bring the risk of death to the operator. For safe operation of the tester, strictly observe the following instructions.

1. Electrification

Be sure to wear a pair of rubber gloves for electrical job, before operating the tester, to prevent electric shock.

2. Grounding:

The protective grounding terminal, on the rear of the tester casing, shall be positively grounded using the applicable tool.

If not properly grounded, the casing of this tester is charged with high voltage when the power is short-circuited to the ground or conveyer or any devices connected to the ground or to the commercial power line (Note i). It is very risky that anyone who touches the casing under such a condition will be subject electric shock.

(Note i) Generally a commercial power line means a line leading to the AC cord socket of the tester, from which the rated power is supplied into the tester.

This manual also covers the power supply line from a private power generator.

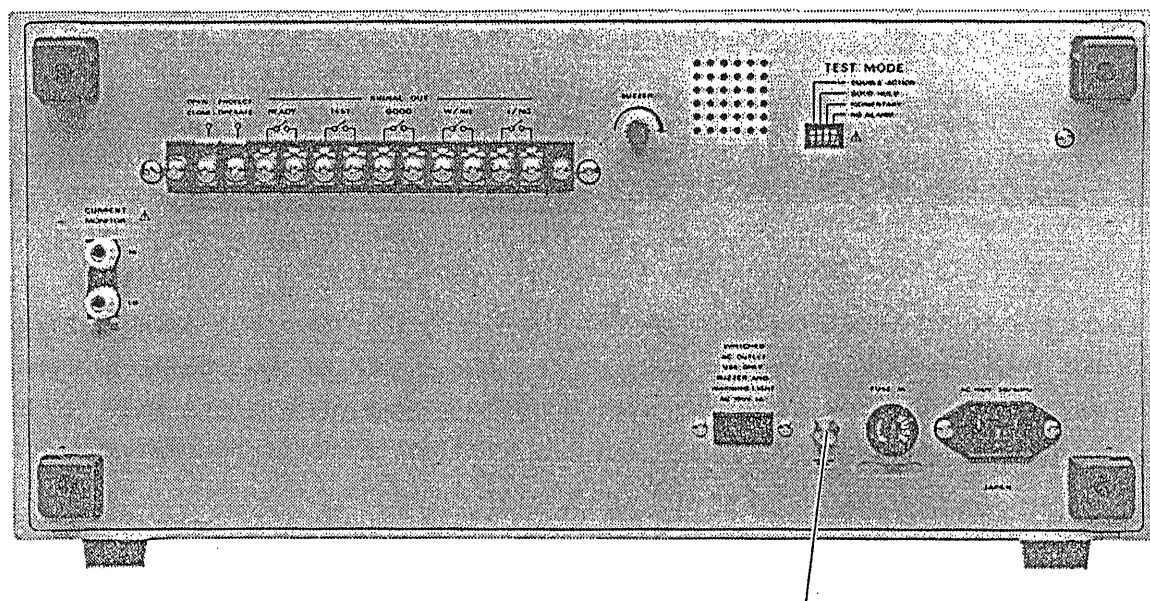

Figure 3.1 Rear of Casing, Model TOS8850

Protective grounding terminal

895299

3. Connecting of test lead-wire on GND side:

Figure 3.2 shows the connection of the test lead-wire on GND side. Every time the tester is used, check if the lead wire is not damaged or disconnected.

The lead-wire connection to the D.U.T. shall be made from GND side. If the connection is incomplete, it is hazardous that the entire D.U.T. may be charged with high voltage.

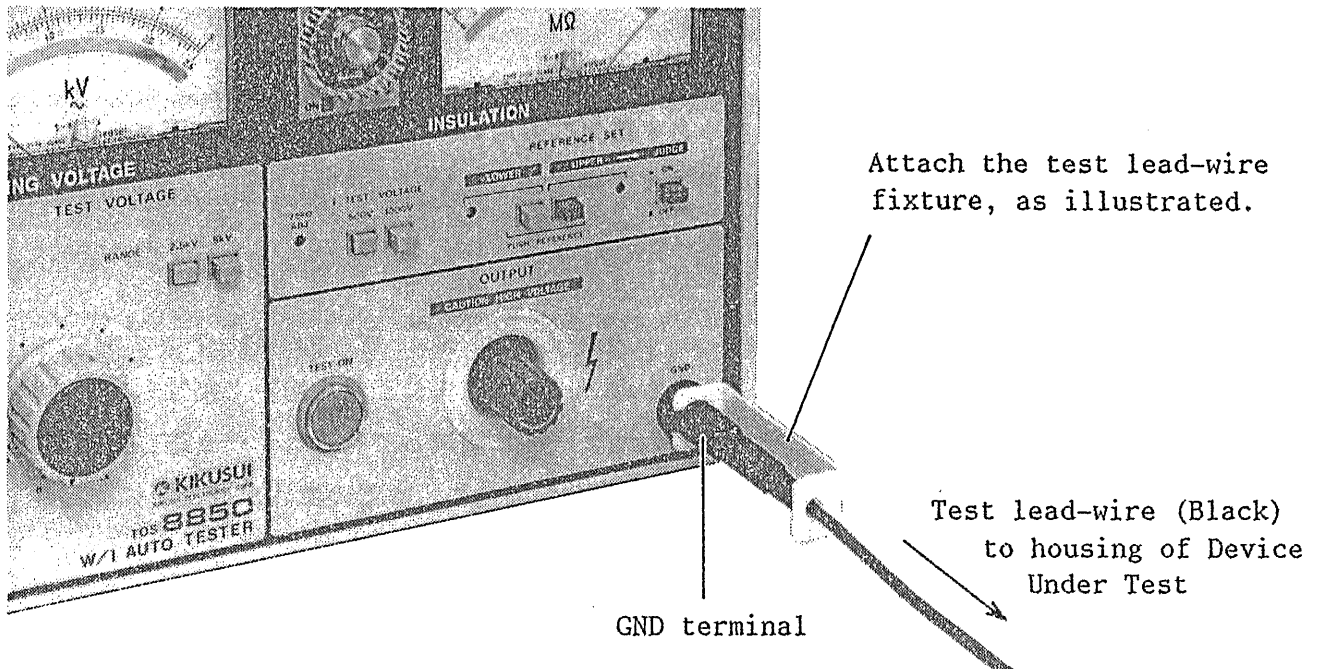

Figure 3.2

4. Connection of test lead-wire on high-voltage output side:

After connecting the lead-wire on GND side, take the following procedure.

- Push the RESET button.
- Confirm if the indicator of the output voltmeter is at "0".
- Confirm if the TEST ON lamp has been off.
- Short the high-voltage output terminal with the GND test lead-wire once, and confirm that no high voltage is output.
- Connect the high-voltage test lead-wire with the high-voltage output terminal.
- Lastly, connect the GND test lead-wire and then the high-voltage output test lead-wire to the D.U.T.

895300

5. Power source switch:

The power switch shall be turned on after confirming that the TEST VOLTAGE dial has been turned to the extreme left ("0" position).

6. Change of test condition:

Change-over of the switches on the panel shall be made after confirming that the RESET button has been pushed in and that the TEST VOLTAGE dial has been turned to the extreme left ("0" position).

7. Suspension of testing:

Except under testing, the TEST VOLTAGE dial shall be turned to the extreme left ("0" position).

Also, push the RESET button (H.V OFF) to ensure safety.

The Power switch shall be turned off if the tester is not used for some time or the operator is to leave from the tester.

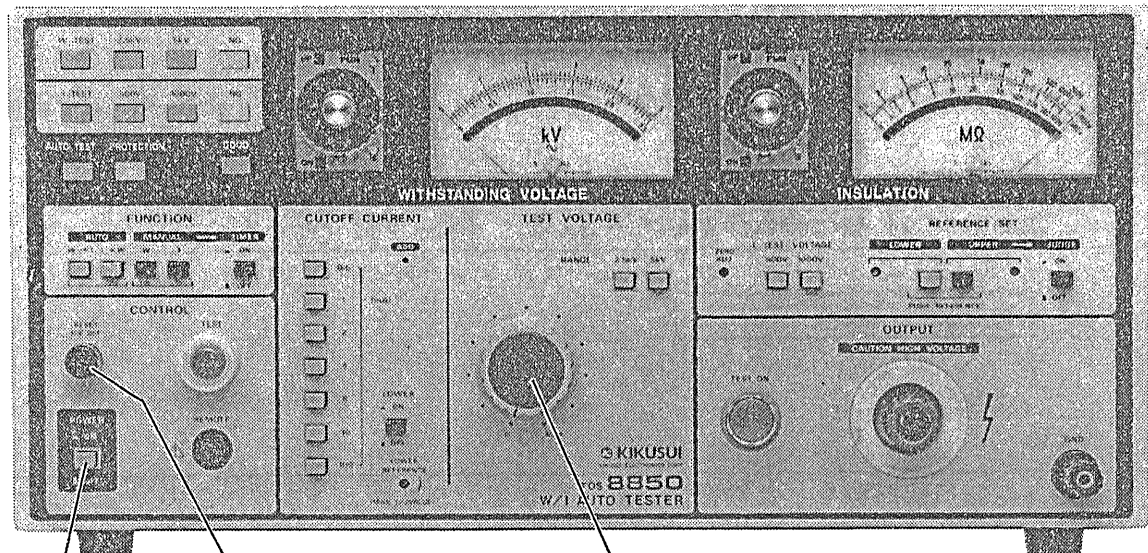

Power switch

RESET button
(H.V OFF)

TEST VOLTAGE
dial

Figure 3.3

895301

8. Critical areas of the tester under operation:

It is dangerous to touch such high voltage areas as the D.U.T., and the test lead-wire, probe and output terminal while the tester is under operation.

Never touch this area!

NEVER touch the alligator of the test lead-wire and the vinyl-cover of the clip because they are NOT insulation proof.

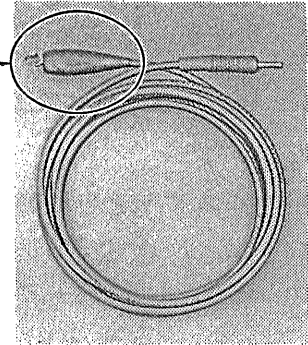

Figure 3.4

— Warning after the output has been cut off —

9. Confirmation on completion of testing:

You may touch the D.U.T. and the high-voltage areas (test lead-wire, probe or output terminal) for correction of the wiring or any other purpose provided that the following confirmation has been made;

- the indication of output voltage is at "0", and
- the TEST ON lamp has been turned off.

In the case of insulation resistance test, D.U.T. is charged after testing. Therefore, a particular attention must be paid to the succeeding paragraphs, 4-10 and 4-11.

— Cautions in electric charging in insulation resistance test —

10. Electric charging:

In case of insulation resistance test, the D.U.T. and the capacitor, test lead-wire, probe and output terminal, embodied in the tester, are charged with high voltage.

And it takes some time to discharge such an electric charge after the power has been cut off.

Accordingly, you should not touch such areas to prevent electric shock for a while after the power has been turned off.

895302

11. Confirmation on discharge of electric charge:

The time required to discharge electric charge depends on the characteristic of the D.U.T. and the test voltage.

Suppose that the high-voltage areas such as the D.U.T and the test lead-wire are an equivalent circuit and that it can be expressed as a capacity of $0.01\mu\text{F}$ and a parallel resistance of $100\text{M}\Omega$, then the time required to attenuate the voltage of the D.U.T. down to 30V will be about 3.5 sec. at the test voltage of 1000V , and about 2.8 sec. at 500V .

If the time constant of the D.U.T. is known, the attenuation time down to 30V , after the power has been cut off, of the D.U.T. can be determined by multiplying the attenuation time given above with such a time constant.

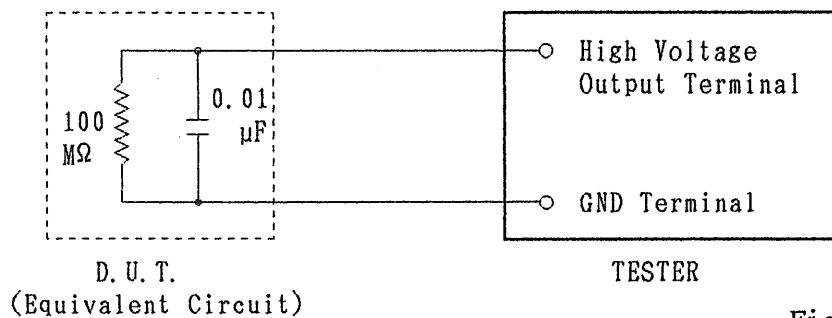

Figure 3.5

12. Remote control of tester:

In the case this tester is to be remote controlled, the application of high voltage to the tester will be controlled by an external signal.

Take the following safety precautions to prevent accident. Also, shall be maintained the safety precaution under positive control.

- NOT to permit unexpected output of high voltage from the tester (that is, to prevent this tester from being put in TEST ON condition).
- NOT to permit operator and any other come into contact with D.U.T. test lead-wire, probe, output terminal, etc. while the tester is generating high test voltage.

13. Re-turn on of POWER switch:

Once the Power switch of the tester has been turned off, leave at least several seconds before it is turned on again. Do not repeat ON-OFF switching of the Power switch particularly when the tester is generating the output voltage. In such a case, the safety protection of the tester

895303

may not work properly, and the operator is endangered.

The power switch shall not be turned off while the tester is generating the output voltage except in the case of emergency.

14. Other precautions:

Do not short-circuit the tester output with the ground or a conveyer or any device connected to the ground, or with the commercial power-line around tester location. Such a short-circuit may cause high-voltage charging on the tester casing, which is very dangerous.

However, such a risky condition will not arise if only the casing has been grounded, in which case the casing will not be electrically charged nor will cause the damage on the tester even when the GND terminal has been short-circuited with the high-voltage terminal.

The protective grounding terminal shall be positively grounded using applicable tool.

— In case of Emergency —

15. Emergency handling:

In the case of any accident such as an electric shock or burn-down of the D.U.T. resulting from the failure of the tester or D.U.T., take the following actions promptly;

- cut off the POWER switch, and
- pull out the plug of AC cord from the socket of the power source.

It does not make any difference whichever action of the above two is taken first, but be sure to take the two actions.

— Trouble-shooting —

16. In case of trouble:

In the following cases of trouble, it is very hazardous that the power of the tester may not be cut off while the tester continues to generate high voltage:

- TEST ON lamp keeps on lighting even when the RESET button has been pushed.
- TEST ON lamp is turned off but the indicator of the output voltmeter continues swinging.

The immediate action to take, in the above cases, is to pull out the plug of AC cord from the the socket of the power source, and suspend the operation of the tester.

Thereafter, entrust us with the trouble-shooting and repair of your defective tester.

If the tester shows any irregular performance, it is possible that a high voltage may be output irrespective of the operator's will.

Suspend the operation of the tester immediately.

17. Fade out of TEST ON lamp:

In the case the TEST ON lamp has been faded out, it may cause erroneous operation of the tester, which in turn give rise to dangerous electrification.

Please entrust us with the repair of such a defective tester.

◆◆ Attention for Trouble-Free Operation ◆◆

- (1) The max. output voltage of this tester reaches higher than 5kV under no-load condition, and even higher voltage in proportion to the power-supply fluctuation. But be sure to operate the tester at a lower voltage than the specified 5kV.
- (2) The heat dissipation capacity of the high-voltage transformer, embodied in the tester, is designed to be a half of the rated output, taking into consideration of the size, weight and cost.
Accordingly, if the test is to be conducted at the CUTOFF CURRENT of 100 mA, leave a suspension time longer than the test duration.
Incidentally, the max. allowable test duration is 30 minutes at ambient temperature of 40°C (104°F) or lower.

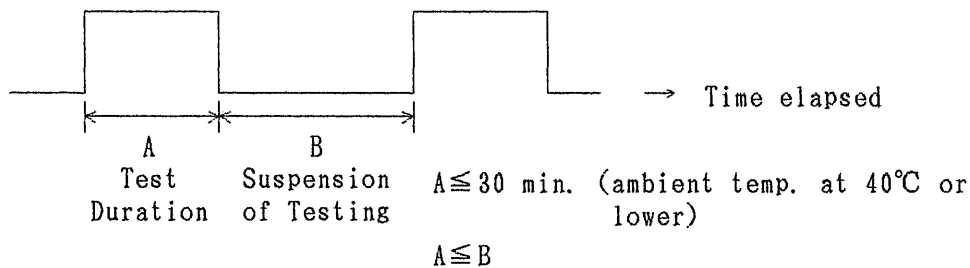

Figure 3.6

The above timing is not applicable if the tester is used at the CUTOFF CURRENT setting of 25.5mA or lower.

895305

- (3) This tester can be properly used with the input power supply of nominal input voltage $\pm 10\%$, but its operation becomes incomplete outside of this range and leads to possible failures.

It is thus important to adjust the power supply within the range of nominal input voltage $\pm 10\%$ by any proper means.

- (4) The operation and storage of the tester under exposure to the direct sunshine, high temperature and humidity or dusty environment should be avoided.

- (5) This tester is incorporated with a transformer of high output voltage up to 500VA.

A considerably large current (in scores of amperes) may flow through the commercial power line, which is connected with the tester in the following two cases:

- In the duration of scores of milli-sec., in which the tester detects that a D.U.T. has failed the testing.
- At an instant when the test is executed.

Also it is important to determine the capacities of the power line and of any electronic device connected to the same line, taking into consideration of such a large current.

- (6) Above 3kV test Voltage this equipment may produce corona discharge between its output cable clips which will generate a significant amount of broadband RF emission. To minimise this effect, support the test clips and cables away from each other and from conducting surfaces, especially from sharp metal edges.

4. OPERATION INSTRUCTIONS

4.1 Description of Front Panel

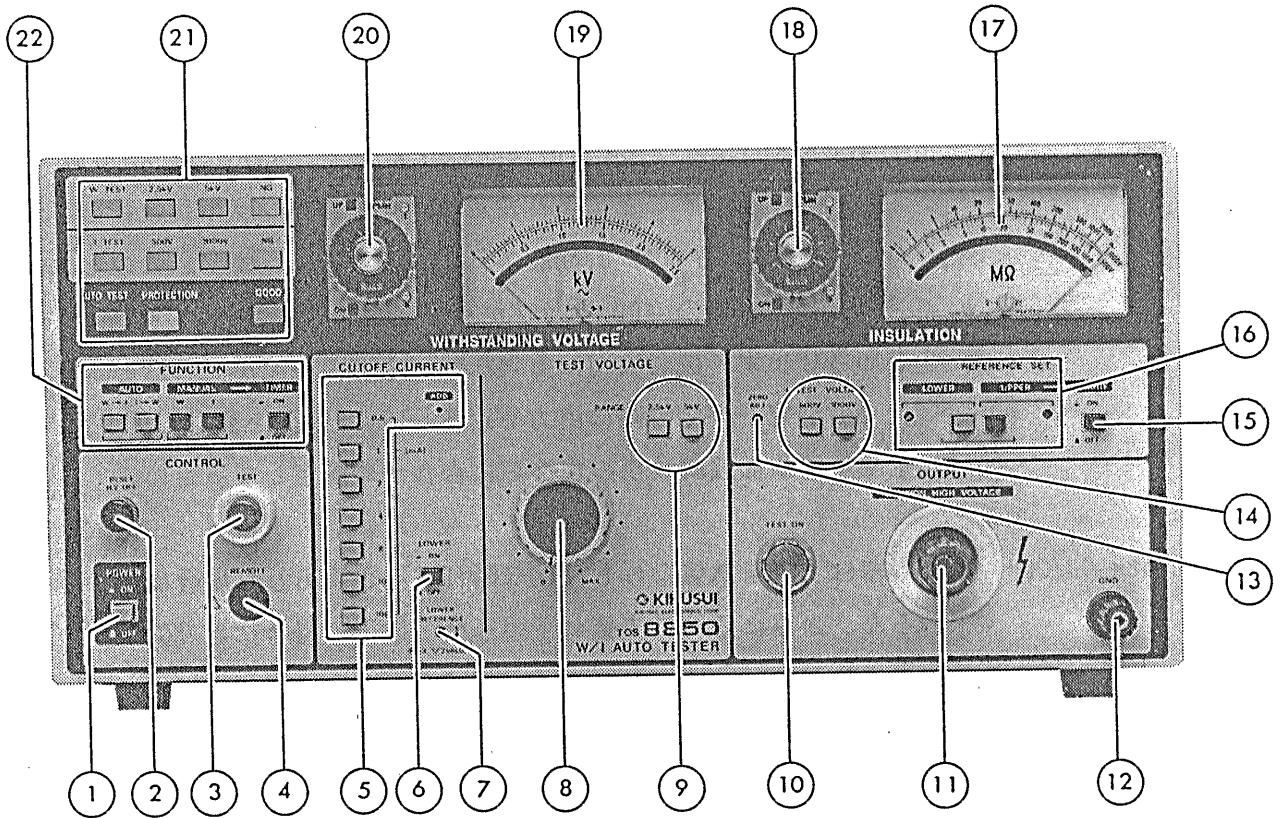

Figure 4.1

① POWER ON/OFF switch:

Main power switch of Tester. Before turning on the switch, be sure to read Section 3. "WARNINGS."

② RESET H.V OFF button:

To cutoff the H.V output when in test operation, press the button. The button is used also to reset from the NC alarm state or the PROTECTION state.

895307

③ TEST button:

As you press the button when the Tester is in the RESET state, the TEST ON lamp illuminates and the test as selected by the FUNCTION selector switch is performed by delivering to the output terminal the test voltage corresponding to the type of test selected.

④ REMOTE CONTROL connector:

When the TEST/RESET operation of the Tester is remote controlled, the connector is used to connect the control signal of the Remote Control Box (RC01-TOS or RC02-TOS) or other devices. Be sure to read Section 4.3.5 "Remote Control" (page 37) before remote-controlling the Tester.

⑤ CUTOFF CURRENT [mA] switches:

The switches select a high limit reference value (upper reference value) of leakage current for withstanding voltage test. The switch values are 0.5, 1, 2, 4, 8, 10 and 100 mA. By pressing one or more of these switches, values are selectable for a range of 0.5 - 25.5 mA in 0.5-mA steps. When two or more switches are pressed, the ADD lamp illuminates to indicate that the set current is the sum of those selected by two or more switches. At the instant the leakage current of the device under test has exceeded the set high limit reference value, an NG judgement is made and the output is cutoff and an NG alarm is generated. Set the high limit reference value as you may require for the device under test.

⑥ LOWER ON/OFF switch:

The Tester is able to make an NG judgement also when the leakage current is less than the low limit reference value (LOWER REFERENCE value), as well as when the leakage current is more than the high limit reference value. The LOWER ON/OFF switch enables or disables this function.

⑦ LOWER REFERENCE value control:

The potentiometer is used to set the low limit reference value for withstanding voltage test (LOWER REFERENCE value). The adjustable range is from zero to one-half of the high limit reference value set by the CUTOFF CURRENT switches. The fully clockwise position of the potentiometer is for one-half of the high limit reference value.

⑧ TEST VOLTAGE dial:

The dial controls the output voltage for withstanding voltage test. The output voltage increases as you turn this dial clockwise. Be sure to set the dial at the fully counterclockwise position (zero position) whenever no test is being done.

⑨ RANGE 2.5kV/5kV switches:

The switches select either the 2.5 kV or 5 kV range for withstanding voltage test. The switches are linked to the output voltmeter to change its ranges.

⑩ TEST ON lamp:

The lamp (red) indicates that the test voltage is ready to be delivered to the output terminal or that it is being delivered.

⑪ OUTPUT terminal:

The hot line of the test voltage.

⑫ GND terminal:

The ground line of the test voltage. Electrically, the line is connected to the Tester chassis.

⑬ ZERO ADJ control:

The potentiometer for electrical zero adjustment of insulation resistance meter.

603768

⑬ ZERO ADJ control:

The potentiometer for electrical zero adjustment of insulation resistance meter. As this adjustment affect insaltion resistance meter of linearity. Please order your Kikusui agent for such service.

⑭ I TEST VOLTAGE 500V/1000V selector switches:

The switches select a test voltaeg for insulation resistance test.

⑮ JUDGE ON/OFF switch:

The switch selects whether the high-limit GO-NOGO judgemnet in the insulation resistance test is to be done or not.

⑯ REFERENCE SET switches:

The switches are for setting a GO-NOGO judgement reference value for insulation resistance test. When neither the UPPER switch nor the LOWER switch is pressed, the ohmmeter indicates the value of measuring resistance. When the LOWER switch is pressed, the ohmmeter indicates the low limit reference value for GO-NOGO judgement; when UPPER switch is pressed, the ohmmeter indicates the high limit reference value. When both switches are pressed, the LOWER switch has a priority. The limit reference values are adjustable with the potentiometers located at right and left of the switches.

⑰ Ohmmeter:

Indicates the resistance measured in insulation resistance test.

⑱ Timer:

Presets the insulation resistance test period. See Section 4.3.8 "Timer" (page 48).

⑲ Voltmeter:

Indicates the output voltage for withstanding voltage test.

② Indicator lamps:

- AUTO TEST: Identifies between automatic test and single test. The lamp illuminates when in the automatic test mode. When in the single test mode, either the W TEST lamp or the I TEST lamp illuminates.
- W TEST: Illuminates when in the withstanding voltage test mode.
- 2.5kV/5kV: Indicate the output voltage range being used for withstanding voltage test.
- I TEST: Illuminates when in the insulation resistance test mode.
- 500V/1000V: Indicate the test voltage being used for insulation resistance test.
- GOOD/NG: Indicate the test result. If the result of GO-NOGO judgement is GOOD, the GOOD lamp illuminates; if it is NG, the NG lamp illuminates. The NG lamp illuminates continuously; the GOOD lamp illuminates only for about 50 msec. (NOTE) SPECIAL TEST MODES: GOOD HOLD OFF. When no timer is used in the single test mode, the GOOD judgement is not done.
- PROTECTION: When in any of the following cases, the protective circuit trips, the output is cutoff and the lamp illuminates. (When this has occurred, remove the cause of the trip and then press the RESET button to reset the Tester.)

(1) When the RANGE 2.5kV/5kV switches of withstanding voltage tester are changed. When both switches are in the pushed-in state (☐ ☐) or pushed-out state (■ ■).

- (2) When the I TEST VOLTAGE 500V/1000V switches are changed. When both switches are in the pushed-in state () or pushed-out state ().
- (3) When the FUNCTION switches are changed. When two or more switches are in the pushed-in state () or all switches are in the pushed-out state ().
- (4) When the REMOTE CONTROL connector is disconnected and then connected. (However, the lamp does not light when a connector which meets the requirements of reset condition is connected.) Without the NG ALARM of the SPECIAL TEST MODE switch ON state.
- (5) When the remote protection input terminals are made open.
- (6) When the POWER switch is turned on again immediately after turning it off.
- (7) When all of the CUTOFF CURRENT switches are set in the pushed-out state or set at 108 mA or more.
- (8) When both withstanding voltage tester and insulation resistance tester are operated at the same time due to a failure of the Tester.

Note: If the lamp does not go off even when you have eliminated the cause of the trip to the PROTECTION state and have pressed the RESET button, the most probable cause is a failure of (8). Immediately stop using the Tester.

② FUNCTION selector switches:

When in the automatic test mode, the switches are used to set the order of withstanding voltage test and insulation resistance test. When in the single test mode, the switches are used to select either one of the two types of tests.

When in the automatic test mode, the test period is as preset by the timer. When in the single test mode, use or unuse of the timer is selectable by the TIMER ON/OFF switch located in the right hand side.

4.2 Description of Rear Panel

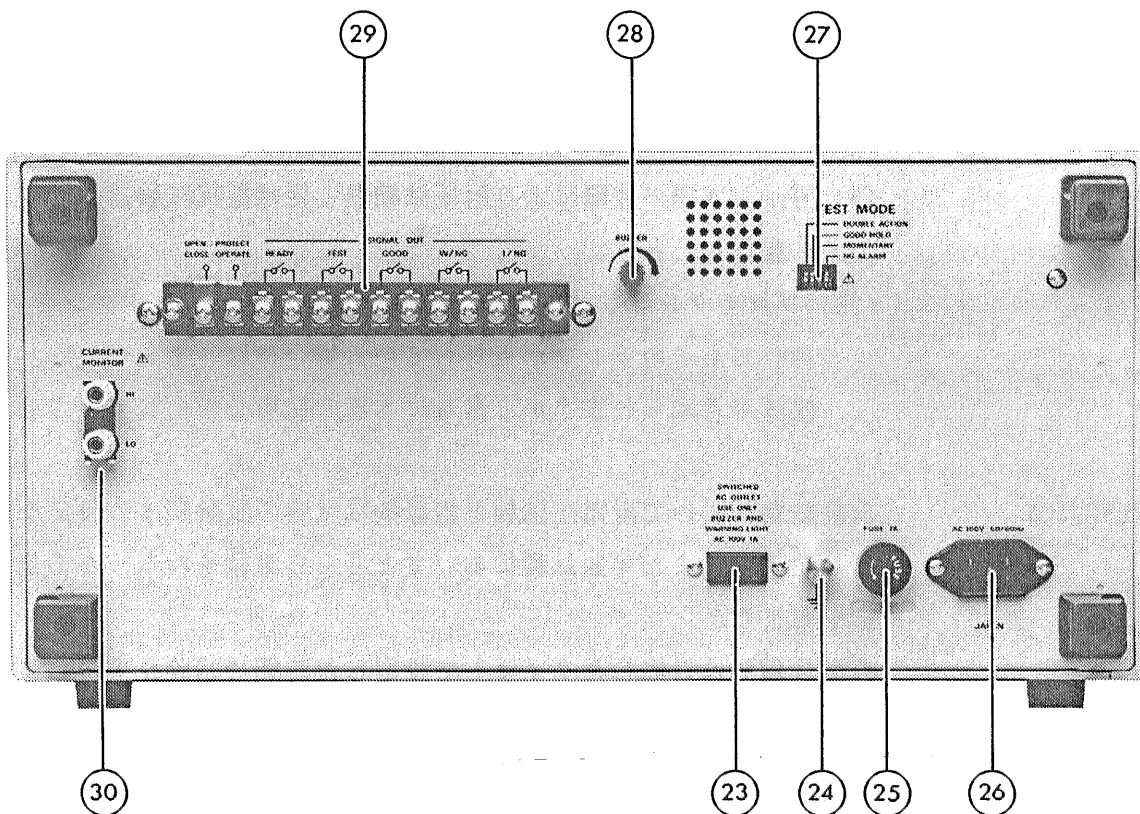

Figure 4.2

②③ SWITCHED AC OUTLET receptacle:

Delivers a 100V AC power for PL01-TOS Warning Light Unit or BZ01-TOS Buzzer Unit (both units are optional). The power is ON/OFF-controlled being linked to the POWER switch on the front panel. The receptacle is dedicated to the above optional units-do not use it for other purposes.

Note: The receptacle delivers the 100 V AC power even when the AC line voltage of the Tester is modified.

②④ Protective GND terminal:

To ground the Tester to an earth line.

②⑤ Fuse:

Fuse of the AC power line

Normal Voltage	Fuse
100 V, 110 V	7 A
115 V, 120 V	
200 V, 220 V	4 A
230 V, 240 V	

②⑥ AC XXXV 50Hz/60Hz connector:

A 3P inlet for AC power line. Use the input power cord which accompanies the Tester.

②⑦ SPECIAL TEST MODE selector switches:

Select the DOUBLE ACTION, GOOD HOLD, MOMENTARY, or NG ALARM mode. Be sure to turn off the POWER switch before setting the selector switches. Refer to Section 4.3.7 "Special Test Modes" (page 46).

②⑧ BUZZER control:

Controls the loudness of buzzer of an NG or GOOD judgement

②⑨ Signal output and remote protection input terminal block

○ SIGNAL OUT terminals:

For the REDAY, TEST ON, GOOD, W/NG, and I/NG output signals (contact signals). See Section 4.3.6 "Output Signals" (page 41).

○ PROTECT/OPERATE terminals:

For REMOTE PROTECTION input signal. Normally the terminals are shorted with a shorting piece. When the terminals are made open, the TEST ON state is inhibited for protection.

③⑩ CURRENT MONITOR terminals:

The leakage current when in withstanding voltage test can be directly monitored by disconnecting the shorting bar from the terminals and connecting a milliammeter between them. The milliammeter should be capable of measuring the leakage current. Be sure to connect the shorting bar when the current is not monitored. A current may flow also when in insulation resistance test and this is not an abnormal indication.

895315

4.3 Operating Procedures

4.3.1 Procedure Before Test

- (1) Before turning on the POWER switch, check that the voltmeter is indicating the "0" scale position and the ohmmeter is indicating the " ∞ " scale position. If the meters are not indicating these positions, adjust them to these positions with their mechanical zero at their centers. If the Tester power is on, turn it off and then check the meters.
- (2) Before turning on the POWER switch, thoroughly read and note the items of Section 3 "WARNINGS."
- (3) When the PROTECTION indicator lamp is illuminating, test is disabled and cannot be started by pressing the TEST button. The conditions for illuminating of the lamp are given on Section 4.1 "Description of Front Panel" (pages 22 through 23). Eliminate the conditions and then press the RESET button to reset the Tester.
- (4) When the POWER switch is turned on or off, the ohmmeter pointer may deflect irregularly. This is only transient and is not an abnormal indication.

4.3.2 Single Withstanding Voltage Test

- (1) Selecting the withstanding voltage test mode:

Select the MANUAL W TEST mode with the FUNCTION selector switches. The W TEST indicator lamp will illuminate.

- (2) Selecting a test voltage range:

Select the required test voltage range (2.5 kV or 5 kV) with the RANGE 2.5 kV/5 kV switches. The corresponding indicator lamp will illuminate.

895316

(3) Setting the high limit reference value of leakage current:

With the CUTOFF CURRENT switches, set the high limit reference value (upper reference value) of leakage current of the device under test as required.

(4) Setting the test time:

Set the test time with the timer as required by the device under test. Refer to Section 4.3.8 "Timer" (page 48).

(5) Setting the test voltage:

Set both TIMER ON/OFF switch and LOWER ON/OFF switch to the OFF state. If the PROTECTION lamp is not illuminating, check that the TEST VOLTAGE dial is at fully counterclockwise position and press the TEST button. Adjust the test voltage by gradually turning clockwise the TEST VOLTAGE dial and reading the voltage on the voltmeter. Then, cutoff the output by pressing the RESET button. Next, set the TIMER ON/OFF switch to the ON state.

If the PROTECTION lamp is illuminating, press the RESET button once and then perform the above procedure.

(6) Connecting the device under test:

First of all, make sure that the output voltmeter indication is zero and the TEST ON lamp is not illuminating. Next, connect the GND test leadwire to the GND terminal of the Tester. With that test leadwire, short the high voltage output terminal to the GND terminal to make sure that no high voltage is being delivered to the output terminal. Then, connect the high voltage test leadwire (hot line) to the output terminal. Connect the GND leadwire to the device under test first and the high voltage test leadwire (hot line) to the device under test next.

895317

(7) Test procedure:

- (a) To start test, press the TEST button.
- (b) When the period set by the timer has elapsed, the test voltage is cutoff and GOOD judgement is made and the GOOD signal is generated in the forms of lamp and buzzer and make-contact signal for about 50 msec.
- (c) When a leakage current larger than the high limit reference value set by the CUTOFF CURRENT switches has flowed, the NG judgement is made and the output is instantaneously cutoff and the NG alarm with the lamp, buzzer and make-contact are generated. Different from the case of the GOOD signal, the NG alarm continue until the Tester is reset or the PROTECTION condition is effected. To reset from the NG state, press the RESET button.
- (d) To abort the test being executed (to cutoff the output) for any reason, press the RESET button.

(8) Single test without using the timer

- (a) The timer of the Tester is for 10 minutes maximum. When a test time longer than this is needed, perform the test without using the timer. However, note that, when the CUTOFF CURRENT switches are set for 100 mA or more, the continuous operation time rating of the Tester is up to 30 minutes. When the current setting is 25.5 mA or less, the Tester may be operated for a longer period.
- (b) Set the TIMER ON/OFF switch to the OFF state.
- (c) Connect the device under test to the output terminals of the Tester as described in Step (6).
- (d) Check that the TEST VOLTAGE dial is set at the fully counterclockwise position and then press the TEST button. The TEST ON lamp will illuminate to indicate that the test voltage is ready to be applied to the device under test. Gradually turn clockwise the TEST VOLTAGE dial until the necessary test voltage is obtained.

81338

When the required test time has elapsed or when a condition calling for aborting the test has occurred, press the RESET button to cutoff the output voltage. In this case the GOOD signal is not generated.

(e) When an NG alarm is generated in the above test, operation is identical with that when the test is mode using the timer.

(9) Re-application of test voltage (retest):

If the Tester is in the RESET state, the test voltage as set by the TEST VOLTAGE dial can be delivered again to the output terminal simply by pressing the TEST button. If the Tester is generating an NG alarm or is in the PROTECTION state, press the RESET button to reset the Tester. If a GOOD judgement is made at the end of the test, the auto reset circuit operates and the Tester is automatically reset.

(10) Setting the GO-NOGO judgement reference values for withstanding voltage test:

(a) The GO-NOGO judgement by the Tester is done in a window comparator system such that the GOOD judgement is made only when the measured leakage current is between the high and low limit reference values. The NG judgement can be made not only when the measured value is larger than the high limit reference value but also when it is smaller than the low limit reference value (0 to one-half of the high limit reference value).

The window comparator system is especially advantageous when the leakage currents of the device under test are predicted to be substantially ununiform. To test such device under test, the high limit reference value may be set at a value slightly larger than the predicted highest value and the low limit reference value may be set at a value slightly smaller than the predicted lowest value, and the test may be done in the window comparator system. When this is done, device under test of exceptionally small leakage currents can be identified and open-circuiting of leadwires and imperfect contacting also can be detected, thereby substantially facilitating the withstanding voltage test.

895319

Tests with low limit judgements for low leakage currents will be inconvenient when setting the test voltage in the no-load state or when the device under test draw almost no current. In such cases, set the LOWER ON/OFF switch to the OFF state to disable the low limit judgement function.

- (b) As mentioned in Note 2 (page 3), when test is made with a high sensitivity using a high AC voltage, it is possible that the current which folws through stray capacitances of the test lead-wires and other device under test becomes larger than the low limit reference value and no low limit judgement for low leakage current can be correctly made. That is, when the device under test is disconnected from the test setup, an NG judgement should be made since the current drawn by the device under test is zero and is absolutely smaller than the low limit reference value. Actually, however, since the current which flows through the stray capacitances is larger than the low limit reference value, the Tester erroneously generates a GOOD judgement signal. Pay attention to this type of judgement errors. Prepare a test setup in a manner that the stray capacitances becomes minimum. Make it sure that the Tester correctly makes NG judgement when the device under test is disconnected from the test setup.
- (c) To set the low limit reference value (LOWER REFFENT value), proceed as follows:
 - (i) Set the high limit reference value (CUTOFF CURRENT value).
Set the TIMER ON/OFF switvh to the OFF state.
 - (ii) Set the LOWER ON/OFF switch in the OFF state. Turn the LOWER REFERENCE value control to the counterclockwise positon.
 - (iii) Connect the device under test as described in Step (6).
 - (iv) Make settings as shown in the flowchart on the next page.

895320

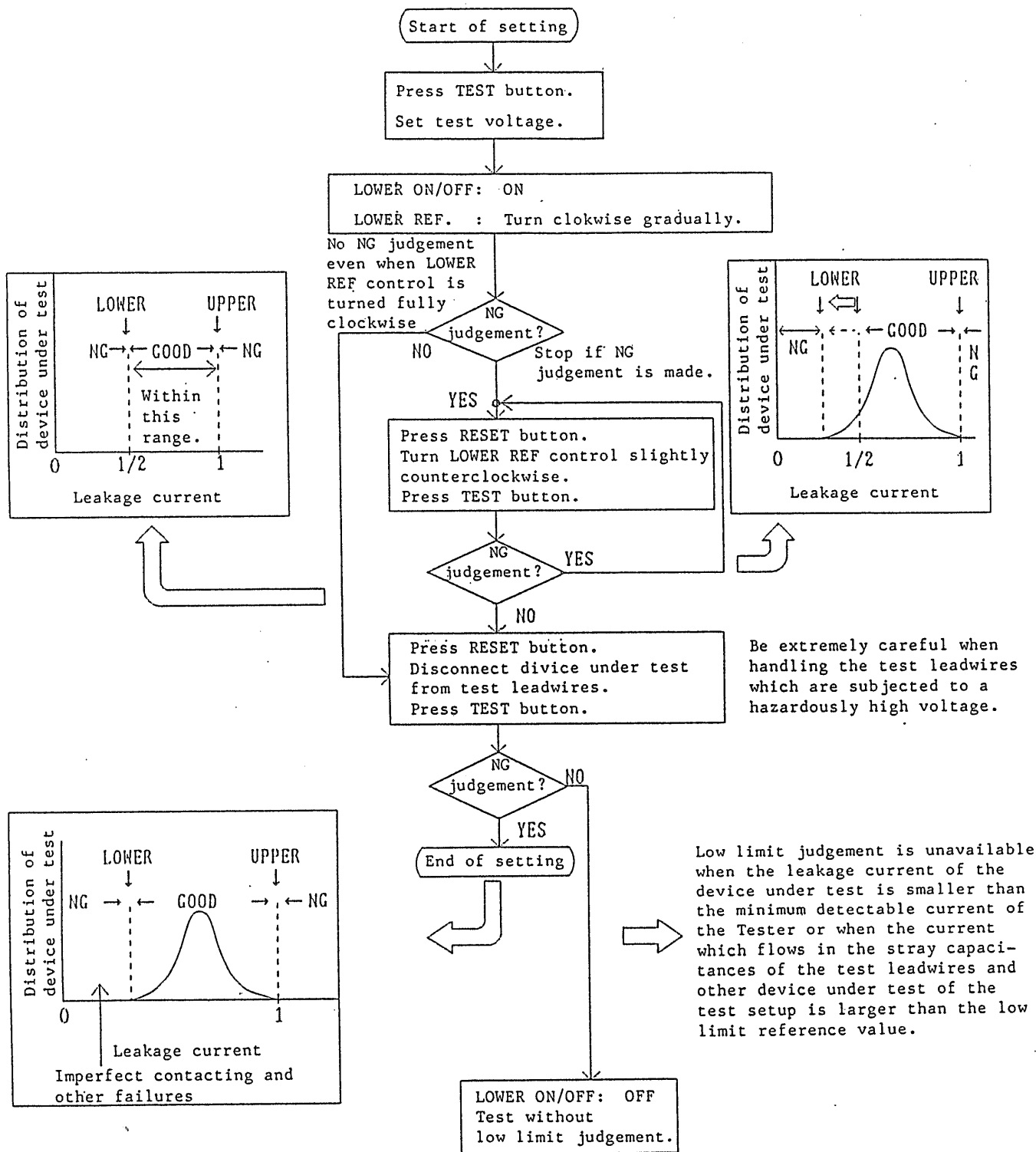

Note 1: For leakage current, the value set by the CUTOFF CURRENT switches is assumed to be the reference (value 1).

Note 2: UPPER: High limit reference value of leakage current for withstanding voltage test
 LOWER: Low limit reference value of leakage current for withstanding voltage test

895321

4.3.3 Single Insulation Resistance Test

- (1) Selecting the insulation resistance test mode:

Select the MANUAL I TEST mode with the FUNCTION selector switches. The I TEST indicator lamp will illuminate.

- (2) Check the Zero-ohm:

Check that the TIMER ON/OFF switch is in the OFF state. With the high voltage OUTPUT terminal shorted to the GND terminal, press the RESET button and then the TEST button. Check The ohmmeter will indicate approxi-mately zero ohms. Zero adjustment potentiometer affect insulation resistance meter of linearity. Please order your Kikusui agent for such service

- (3) Selecting a test voltage:

Select the required test voltage (500 V or 1000 V) with the I TEST VOLTAGE 500V/1000V selector switches.

- (4) Setting the GO-NOGO judgement reference values for Insulation resistance test:

- (a) The GO-NOGO judgement by the Tester is done in a window comparator system such that the GOOD judgement is made only when the measured insulation resistance is between the high and low limit reference values. The NG judgement is made not only when the measured value is lower than the low limit reference value but also when it is higher than the high limit reference value.

The window comparator system is especially advantageous when the insulation resistances of the device under test are predicted to be substantially ununiform. To test such device under test, the high limit reference value may be set at a value slightly higher than the predicted highest value of the device under test and the test may be made in the window comparator system. When this is done, device under test of exceptionally high insulation resistances can be identified and open-circuiting of leadwires and imperfect contacting also can be detected, thereby attaining still

- (b) With the REFERENCE SET switches set in the regular state (pushed-out state $\begin{matrix} L \\ \text{L} \end{matrix}$ $\begin{matrix} U \\ \text{U} \end{matrix}$), the ohmmeter indicates the measured resistance when in the insulation resistance test. When not in the insulation resistance test, the ohmmeter indicates the ∞ position.
- (c) Press the LOWER REFERENCE SET switch, and the ohmmeter will indicate the low limit reference value. Next, press the UPPER REFERENCE SET switch, and the ohmmeter will indicate the high limit reference value. When the two switches are pressed at the same time, the LOWER REFERENCE SET switch has a priority.
- (d) The high and low limit reference values can be set with the potentiometers located at right and left of the switches. Set the values as required by the device under test.
- (e) For some types of tests, it may be undesirable to perform high limit judgement. In such cases, set the UPPER ON/OFF switch in the OFF state.

When the low limit judgement is not required, turn the low limit reference value setting potentiometer so that the ohmmeter pointer for the low limit reference value indicates a position lower than the zero ohm scale position.

(5) Setting the test time:

Set the TIMER ON/OFF switch to the ON state. Set the test time as required by the device under test (within a range of 0.5 seconds to 10 minutes with the timer). Refer to Section 4.3.8 "Timer" (page 48).

(6) Connecting the device under test:

Connect the device under test to the Tester in the same manner as in the case of withstanding voltage test.

(7) Test procedure:

- (a) If the PROTECTION indicator lamp is illuminationg, press the RESET button to reset the Tester. If the Tester is already in the RESET

state, test can be immediately started simply by pressing the TEST button.

(b) If the device under test satisfies the conditions of GOOD judgement set for GO-NOGO judgement in Step (4), the ohmmeter will indicate the measured resistance value. When the preset time has elapsed, the test voltage is cutoff, the device under test is judged to be good, and the Tester will generate GOOD signals with the lamp, buzzer and make-contact for approximately 50 msec.

(c) If the device under test does not meet the above-mentioned test conditions, the NG judgement is made and the output is instantaneously cutoff and the NG alarm is generated.

The alarm is with the lamp and make-contact which are different from those for the withstanding voltage test and with the buzzer which is used in common for the withstanding voltage test.

To reset the alarm, press the RESET button.

(8) Test without using the timer:

Set the TIMER ON/OFF switch to the OFF stage. When this is done, insulation resistance test can be done irrespective of the timer as is the case for withstanding voltage test. If the Tester is in the RESET state, the test will start as you press the TEST button. As you press the RESET button, the output voltage is cutoff and the test ends.

(9) Re-application of test voltage (retest):

The re-application method of the test voltage is the same as that of the case of the withstanding voltage test.

(10) Checking discharge from D.U.T.

In case of this mode (Single Insulation Resistance Test), D.U.T is charged after testing. Be sure to check discharge from D.U.T. Read the instruction given on page 13 - 14, items 10 and 11 for the detail.

4.3.4 Automatic Test

(1) Selecting a test sequence

The Tester is capable of performing a withstanding voltage test and an insulation resistance test sequentially. Sequence is selectable for "W → I" or "I → W" with the FUNCTION switches. When the Tester is set for this mode, the AUTO lamp illuminates. (Letter "W" stands for withstanding voltage test and letter "I" for insulation resistance tests.)

(2) Setting the test conditions:

Set the test voltages of withstanding voltage test or insulation resistance test, leakage current detection reference values, test time, and insulation resistance judgement reference values as in the case for the single-item tests.

(3) Connectings the device under test:

Connect the device under test to the output terminal of the Tester as in the case for the single-item tests.

(4) Test procedure:

- (a) Set the Tester in the RESET state and then press the TEST button. The Tester will automatically perform the two types of tests.
- (b) When the test is over without the NG judgement, the GOOD signals are generated at the end of the test. The signals are the same with those of the single test.

When the withstanding voltage test or insulation resistance test is over with NG judgement, the output voltage is instantaneously cutoff the NG alarm is generated, and the test is end.

The signals are the same with those of the single test.

(5) To abort the test:

To abort the test being performed, press the RESET button. The output voltage will be instantaneously cutoff and the Tester will be RESET

895325

state.

- (6) Re-application of test voltage (retest):

When the test is over with the GOOD judgement, the Tester generates the GOOD signals for approximately 50 msec and then resets itself.

The next test can be started simply by pressing the TEST button. When the Tester has generated the NG alarms, reset once the Tester and then press the TEST button.

- (7) Checking discharge from D.U.T.

In case of "W → I" test mode, D.U.T is charged after testing. Be sure to check discharge from D.U.T. Read the instruction given on page 13 - 14, items 10 and 11 for the detail.

4.3.5 Remote Control

- (1) The TEST/RESET operation of the Tester can be remote-controlled with the remote control box (optional). As the plug of the remote control cable is connected to the REMOTE CONTROL connector on the Tester front panel, the internal circuit is automatically switched to the remote operation mode. In this case, the TEST button on the Tester front panel is disabled, although the reset operation can be done either at the Tester front panel or at the remote control box.

The Tester can be remote-controlled by other control system equipment without using the remote control box. This method is explained below.

Be extremely careful when using this method because the high voltage is on/off -controlled with an external signal. Pay attention so that the high test voltage is not generated inadvertently. Also, provide full measures to ensure that nobody is contacted with the high voltage areas (D.U.T. test lead-wire, probe or output terminal etc.) when the test voltage is being delivered.

When these measures are unavailable, do not use the following remote control method.

- (a) Because the instrument can operate by remote control, the pin No.2 and No.3 of connector must be externally connected.
- (b) By controlling the TEST and RESET contacts shown in Figure 4.3, test voltage can be on-off controlled in the same manner as done at the Tester front panel. (Special Test mode: NG ALARM OFF)
- (c) In the case of the setup shown in Figure 4.4, the test voltage is turned on when the switch is thrown to the NO position, and Tester is forcefully reset when the switch is returned to the NC position. (Special Test mode: NG ALARM OFF)

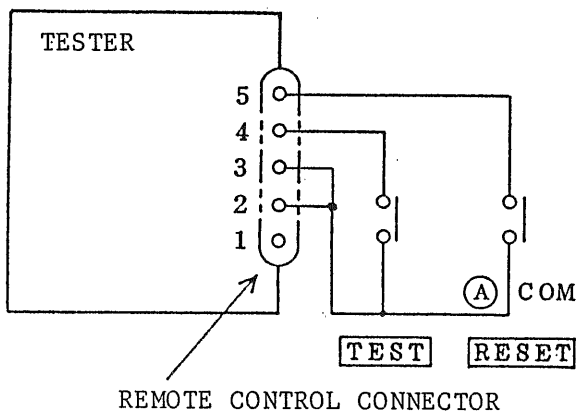

Figure 4.3

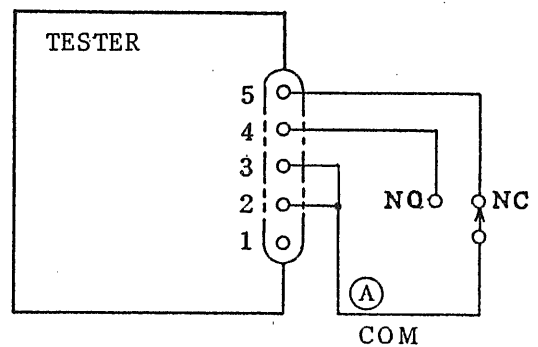

Figure 4.4

- (d) Logical elements, transistors, FET's, or photocouplers may be used instead of the switches in Figure 4.3. The example is shown in Figure 4.5. The input conditions of the Tester for such operation are as follows:

- High level input voltage: 11 - 15 V
- Low level input voltage: 0 - 5 V
- Low level sweep out current: $\leq 2\text{mA}$
- Input pulse width: 20 msec minimum

Notes: 1. The gates are pulled up to +15 V. Opening of the input terminals is equivalent to a high level input.

192.1.28

895827A

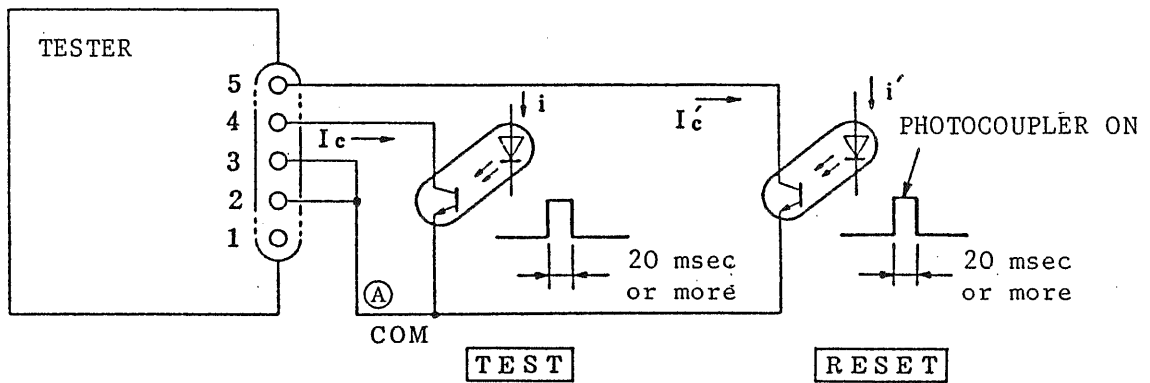
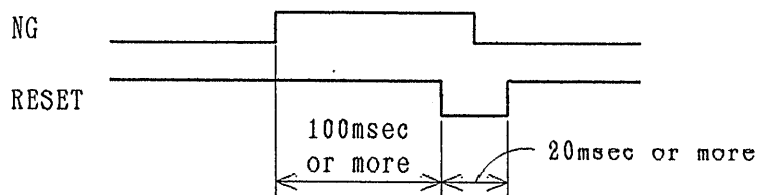

Figure 4.5

2. Currents i and i' must be sufficient to provide currents I_c and I_c' of 2 mA or more.
3. When using the CURRENT MONITOR terminals, isolate the common line (line (A) in Figure 4.5) of the control circuit from the power line and ground line of the Tester.
4. The timing of the RESET signal for clearing the NG alarm is as follows.



- (e) With a view to prevent erroneous operation which could be caused by noise, it is recommendable to use photocouplers as shown in Figure 4.5 or relays as shown in Figure 4.3. The Tester is designed with full attention so that it does not erroneously operate by noise. Pay attention so that the devices connected to the tester do not erroneously operate by noise.

192. 7. 28

895328A

- (f) Note that the layout of pins of the REMOTE CONTROL connector is as per DIN standard and is not in the due order of number progression, as shown in Figure 4.6.

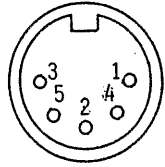

Layout of connector pins as viewed from panel surface

Figure 4.6

- (2) The Tester can be remote-controlled for PROTECTION state with an external signal through the PROTECT/OPERATE input terminals on the rear panel.

If the Tester is in the PROTECTION state, on test voltage is delivered even when a test input signal is applied (or the TEST button is pressed) thereby maintaining the protected state. With this feature, erroneous delivery of the output voltage by an erroneous external condition can be eliminated to protect the operator.

An example of setup for the remote PROTECT/OPERATE control function is shown in Figure 4.7. When the contact shown in Figure 4.7 is open, the Tester is in the PROTECTION state. When the contact is closed and a reset signal is applied (or the RESET button is pressed), the Tester is reset to the state that it is ready to perform the test. When the Tester is shipped, the PROTECT/OPERATE input terminals are shorted with a shorting piece.

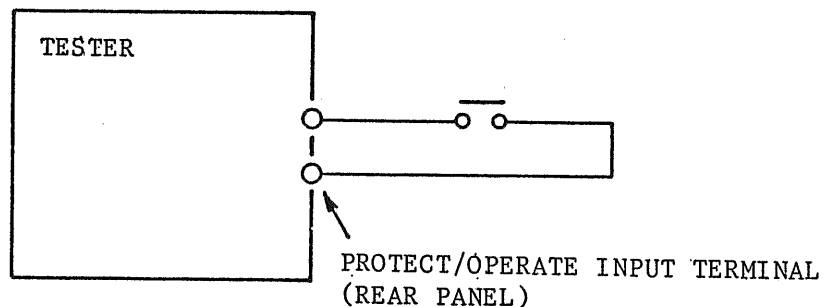

Figure 4.7

792.7.28

895329A

4.3.6 Output Signals

- (1) The Tester delivers the following signals other than the lamp and buzzer signals.

No.	Signal	Condition for Delivery	Type and Rating
①	TEST ON	Entire period during test is on	Make-contact signal Ratings: 100 V AC, 1 A 30 V DC, 1 A
②	GOOD	When test is over. Approx. 50 msec	
③	W/NG	When NG judgement is made for withstanding voltage test. Continuous	
④	I/NG	When NG judgement is made for insulation resistance test. Continuous	
⑤	READY	When in ready for test	

- ① TEST ON signal: This signal is generated and remains on for the entire period of either the single test or the automatic test.
- ② GOOD signal: This signal is generated when a GOOD judgement is made at the end of a single test with the timer or at the end of the latter one of automatic tests. The signal lasts for approximately 50 msec.
- ③ W/NG alarm: This signal is generated when an NG judgement is made for the withstanding voltage test. This signal remains on until the next reset signal is applied (or the RESET button is pressed) or the PROTECTION signal is applied.
- ④ I/NG alarm: This signal is generated when an NG judgement is made for the insulation resistance test. The conditions for resetting the signal are the same as above.

- ⑤ READY signal: This signal is continuously delivered when the Tester is in the READY state (the state that the Tester is ready to be driven into the TEST ON state). That is, this signal is delivered when power of the Tester is turned on but a RESET signal is not applied (or the RESET button is not pressed), not in the TEST ON state, not generating the GOOD signal or NG alarm, and is not in the PROTECTION state.

As the TEST signal is applied (or the TEST button is pressed) when the READY signal is being delivered, the Tester starts the test operation.

Note: When in the MOMENTALY of Special Test Mode, this signal is not generated.

(2) Contact signals

- ① The contact signals are only with contacts and without any power sources as Figure 4.8. Therefore, cannot drive any loads which have no power.

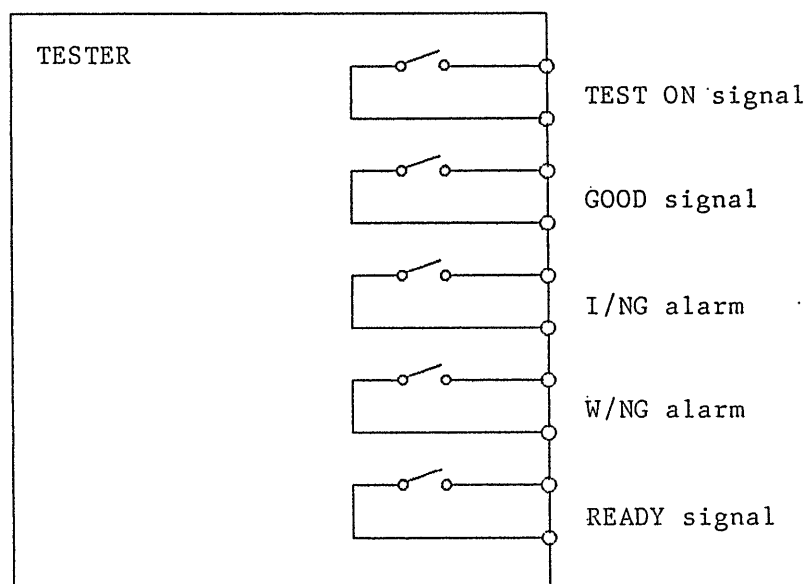

Figure 4.8

895331

A contact which is closed when the signal is applied is called make contact, normally open contact, or form "a" contact. A contact which opens when the signal is applied is called break contact, normally closed contact, or form "b" contact.

The contacts of the Tester are of the make-contact type and their rating is 100 V AC, 1 A or 30 V DC, 1 A.

The withstanding voltage is 500 V AC 1 minute between the circuit and chassis.

② Examples of use of these contacts are illustrated in the following.

(a) To drive a DC buzzer with an W/NG or I/NG alarms.

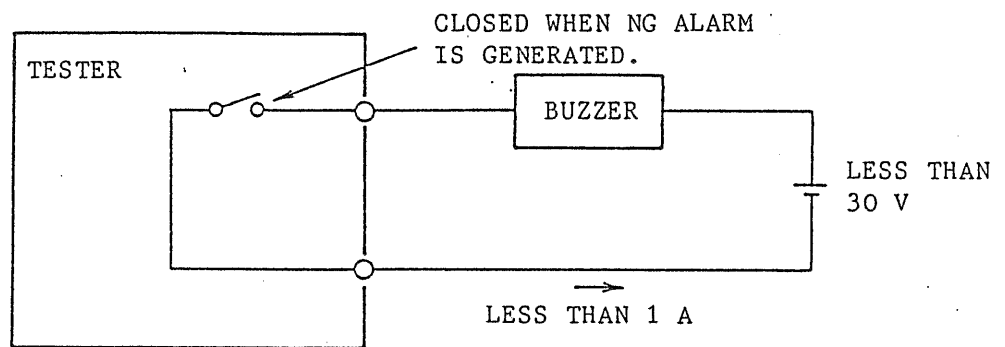

Figure 4.9

(b) To drive a lamp with the TEST ON signal:

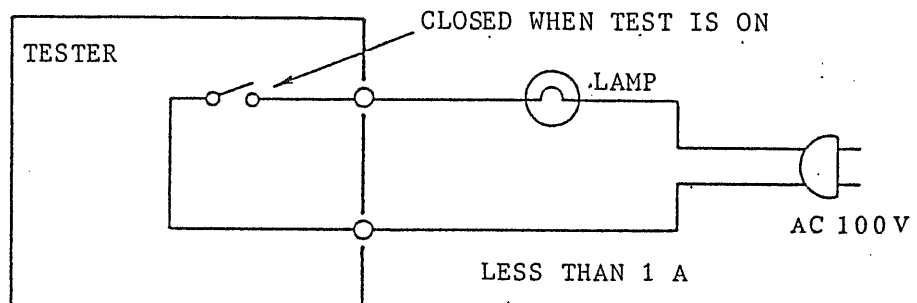

Figure 4.10

895332

(c) To obtain an "L" level digital signal with the contact signal:

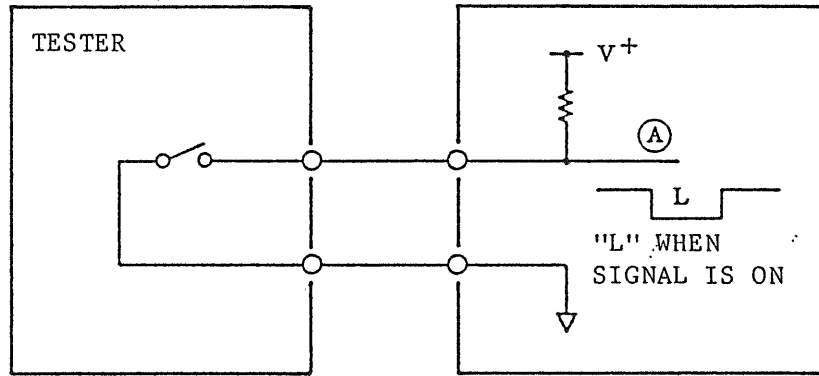

Figure 4.11

In the above illustration, an "L" level signal is obtained at point \textcircled{A} when the contact output signal is on. However, since the signal obtained at point \textcircled{A} include chattering, an appropriate chattering suppression provision should be incorporated depending on the nature of the circuit to be driven by this signal. In some cases, a noise suppression provision may be necessary.

③ Precaution on using the contact signal

Before using this contact signal, provide a contact protection measure (to absorb surge) suitable to the using method. Failure can not only cause malfunction of the circuit being connected later but also break the contact of the tester.

The figure 4.12 and 4.13 are the examples of the contact protection method recommended.

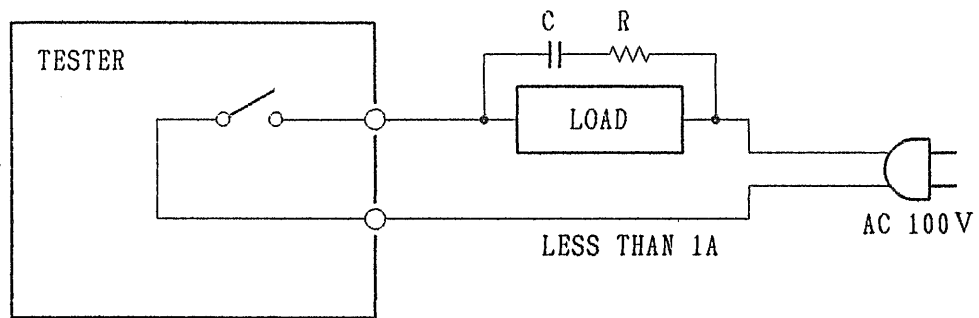

R : Approx. 100Ω 2W or over

C : Approx. $0.1\mu\text{F}$ AC 250V or higher

(The R and C are reference values only. Select proper values in accordance with the actual conditions.)

Figure 4.12

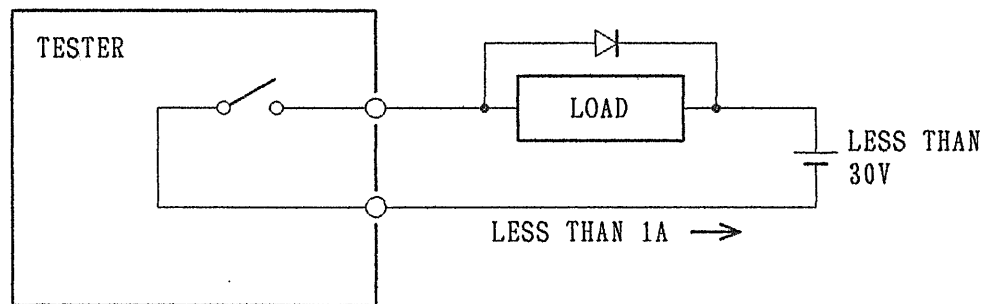

Diode

Reverse voltage 200V or higher

Foward current 1A or more

(The diode ratings are reference value only. Select proper values in accordance with the actual conditions.)

Figure 4.13

895334

4.3.7 Special Test Modes

TEST MODE

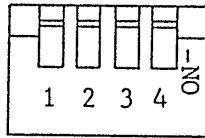

Figure 4.14

Four types of special modes are selectabel with the TEST MODE selector switches on the rear panel. The standard positions of the switches (the positions as the switches are set as the Tester is shipped) are the OFF positions as shown in Figure 4.14.

By throwing the switches to the ON positions, respective modes as described below can be selected. Since mode settings are mutually independent, any combinations of switch settings are possible.

(1) DOUBLE ACTION:

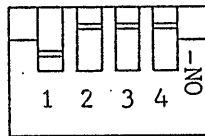

Figure 4.15

For the DOUBLE ACTION mode, set the switches as shown in Figuer 4.15. When in the RESET state in the standard mode, as you press the TEST button, the Tester is driven into the TEST ON state. When in the DOUBLE ACTION mode, the Tester is driven into the TEST ON state provided that you press the TEST button within approximately 0.5 seconds after pressing the RESET button. That is, no test is started unless both RESET and TEST buttons are pressed in the correct sequence within a certain period. While the procedure is more complicated due to the double switch actions, a higher safety of test can be attained.

The function is the same as above also when in the remote control mode.

(2) GOOD HOLD:

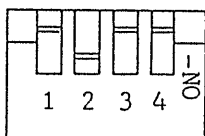

Figure 4.16

For the GOOD HOLD mode, set the switches as shown in Figure 4.16. When a GOOD judgement is made in the standard mode, the Tester generates a GOOD signal only for approximately 50 msec. When in the GOOD HOLD mode, the GOOD signal is continuously held until the RESET signal is applied.

805335

(3) MOMENTARY:

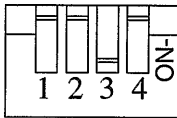

Figure 4.17

For the MOMENTARY mode, set the switches as shown in Figure 4.17. When in the standard mode, once the TEST button is pressed, the TEST ON state is maintained until the period set by the timer elapses or the RESET button is pressed. When in the MOMENTARY mode, the TEST ON state is maintained only for the period the TEST button is kept pressed.

As you release the TEST button, the test stops instantaneously. Thus, the MOMENTARY mode is advantageous from the viewpoint of operation safety.

Still higher operation safety can be attained by operating the Tester in the MOMENTARY mode and using RC02-TOS Remote Control Box (both-hand type, option) in conjunction.

When test is made with the timer, the Tester generates a GOOD signal for approximately 50 msec after the test for the period preset by the timer has elapsed, and then the test ends.

Note: When in this mode, the READY signal is not generated.

(4) NG ALARM:

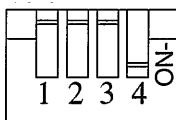

Figure 4.18

For the NG ALARM mode, set the switches as shown in Figure 4.18. When the Tester is set in the standard mode, as a remote RESET signal is applied, the test voltage is cutoff and the NG alarm and PROTECTION state and GOOD signal are reset as in the case that the RESET button on the front panel is pressed.

When in the NG ALARM mode, as a remote RESET signal is applied, although the output is cutoff and the GOOD signal is reset, the NG alarm and the PROTECTION state are not reset. To reset the NG alarm and PROTECTIONS state, press the RESET button on the front panel.

This mode provides an effective means for confirming the NG alarm when HP01A-TOS or HP02A-TOS High Voltage Probe (optional) is used.

4.3.8 Timer

The timer has two slide switches to select four time ranges. The units of time and figures on the scale plate also are changed as the switches are changed, allowing you to directly read the set time range.

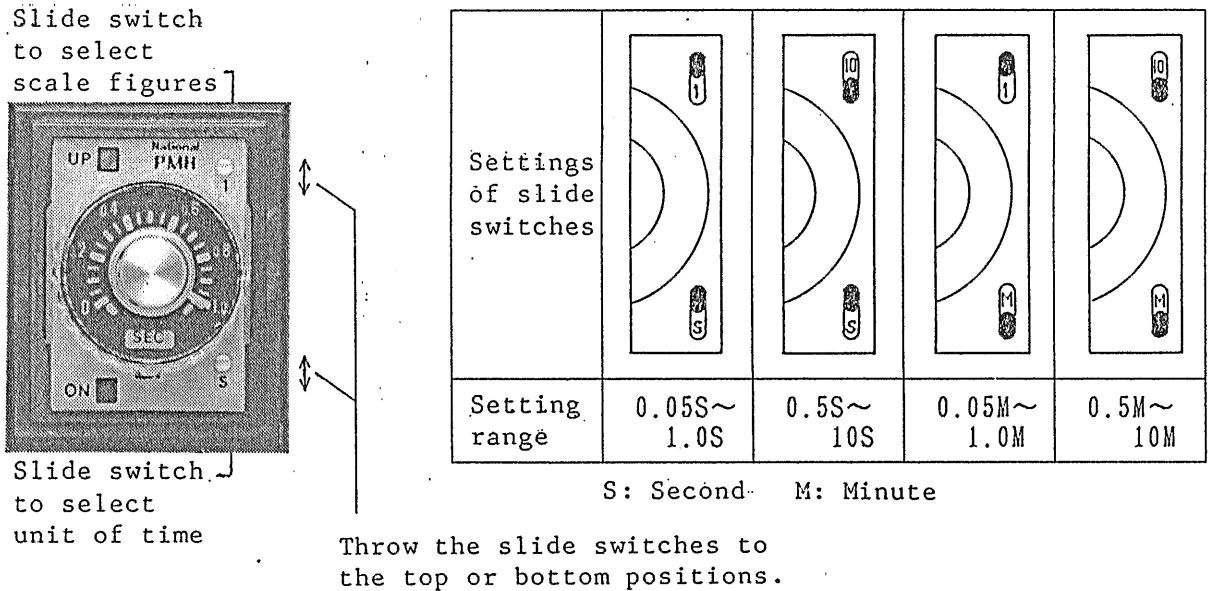

Figure 4.19 Timer and Slide Switches

Note 1: When the low limit judgement is used for withstanding voltage test, be sure to set the timer for 0.2 seconds or a longer period.

Note 2: For insulation resistance test, be sure to set the timer for 0.5 seconds or a longer period. Refer to Section 5.4 "Waiting-time for Judgement in Insulation Resistance Test." (page 53)

895337

5. OPERATING PRINCIPLE

5.1 Block Diagram

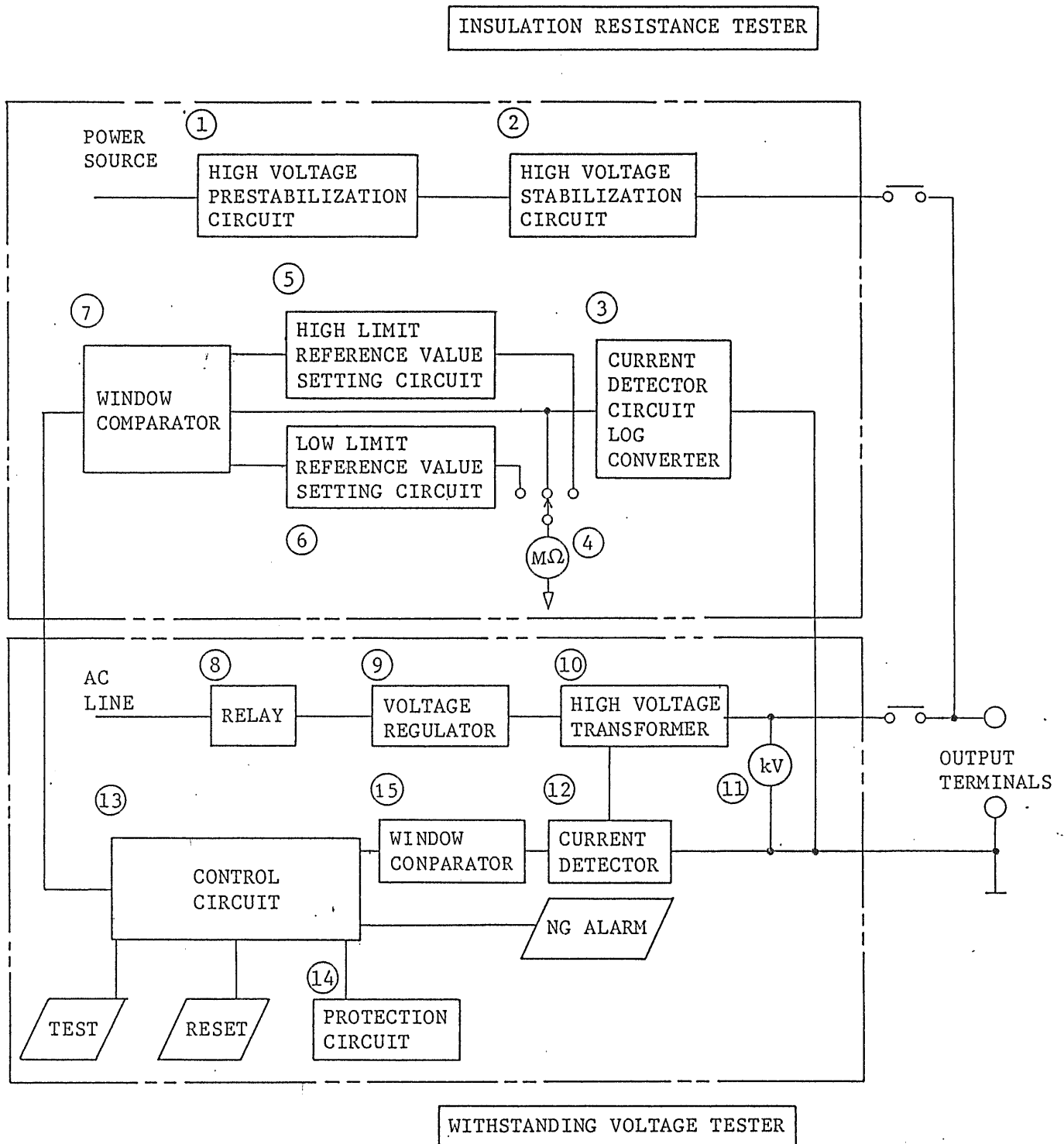

Figure 5.1

5.2 Descriptions of Individual Circuits

① High voltage prestabilization circuit:

In order to obtain the high voltage required for insulation resistance test, this circuit tripple-voltage rectifies the AC input power and roughly prestabilizes the DC output voltage at approximately 1150 V.

② High voltage stabilization circuit:

Stabilizes the above DC voltage more finely, in order to be applied as an insulation resistance test volatge to the device under test.

The test voltage is a negative voltage of nominal 1000 V or 500 V.

③ Current detector circuit with log converter:

The current which flows in the device under test varies ranging from less than 1 μ A to approximately 1 mA when shorted.

To detect and indicate this wide dynamic range current on the single range scale of the ohmmeter, this circuit has a log converter which converts the detected signal into a logarithmic signal. A highly accurate log converter is used in order to satisfy the specification accuracy.

④ Ohmmeter:

This meter is driven by the above logarithmic signal to indicate the insulation resistance of the device under test.

⑤ High limit reference value setting circuit:

Sets the high limit reference value for GO-NOGO judgement. The value is adjustable with its potentiometer on the front panel.

⑥ Low limit reference value setting circuit:

Sets the low limit reference value for GO-NOGO judgement. The value is adjustable with its potentiometer on the front panel.

894339

⑦ Window comparator:

Generates a GOOD signal if the measured value is within the range between high and low limit reference values. If not, generates an NG signal.

⑧ Relay:

On-off controls the power applied to the voltage regulator for withstanding voltage test. A solid-state zero-start type relay circuit is employed to minimize transiential spike voltages caused when the high voltage output is turned on or off.

⑨ Voltage regulator:

A slide transformer is used to control the output voltage.

⑩ High voltage transformer:

Boosts the voltage regulator output with a ratio of 1:25 or 1:50 into a high output voltage of 0 to 2.5 kV or 0 to 5 kV. The rating is 5 kV, 100 mA (500 VA) when the AC line voltage is 100 V.

⑪ Voltmeter:

Indicates the output voltage for withstanding voltage test.

⑫ Current detection circuit:

Consists of a current detecting resistor, a reference voltage generator circuit, and a comparator.

⑬ Control circuit:

Controls overall operations of the Tester. Structured in high-reliability logic circuits with CMOS IC.

⑭ Protective circuits:

Various protective features are incorporated for the safety of tests. But be careful to operate.

⑮ Window comparator:

Generates a GOOD signal only when the leakage current is within the range between the high limit reference value set with the CUTOFF CURRENT switches and the low limit reference value set with the LOWER REFERENCE value control. When the leakage current is not within the above range, the comparator generates an NG judgement.

5.3 Zero-start Switch

If a regular mechanical contact type relay is used for on-off operation of the primary circuit of the high voltage transformer, transiential spike voltages could be produced, thereby applying an unjustifiedly high voltage to the device under test (DUT) and causing a possibility of rejecting an acceptable DUT. The zero-start switch, which employ a solid-state switching circuit, turns on and off the power line at approximately 0 volt level, thereby reducing transiential overshoots.

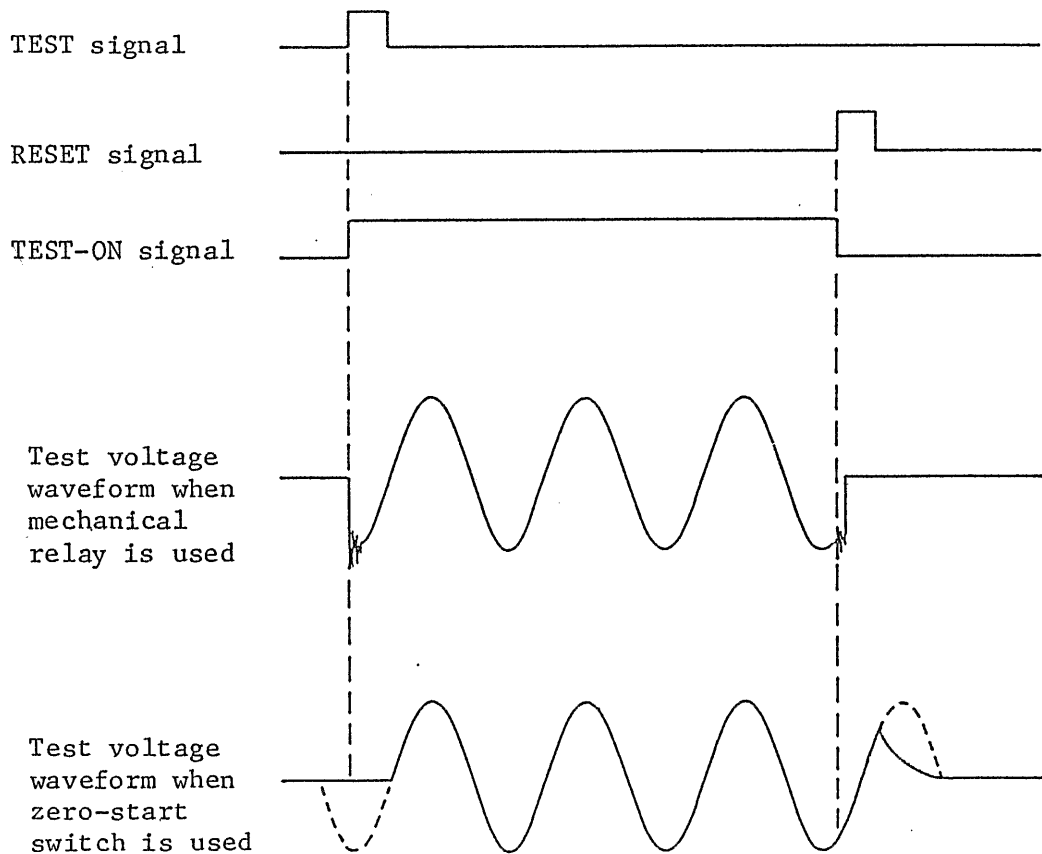

Figure 5.2

895341

5.4 Waiting-time for Judgement in Insulation Resistance Test

When a test voltage is applied to a DUT which has a larger capacitance, a larger charge current will flow at the initial short period and the resistance of the DUT may be indicated lower than the actual value. In order to eliminate such period from the GO-NOGO judgement period, a time delay provision is incorporated. The delay time is set at approximately 0.3 seconds. If the timer is set at a period shorter than 0.3 seconds, the effect of the above provision will be lost and a GOOD judgement may be made erroneously. Be sure to set the timer for a period longer than 0.5 seconds.

6. MAINTENANCE

6.1 Cautions

A hazardously high voltage of a level of 5 kV is generated within this Tester. Never-attempt to repair the Tester for yourself. For such service, contact your Kikusui agent.

This section covers the calibration procedure of the Tester. Be extremely careful not to touch the electrically charged parts.

6.2 Calibration

This section covers the following calibration procedures.

- Calibration of voltmeter of withstanding voltage tester
- Calibration of high limit reference (CUTOFF CURRENT) value of leakage current for withstanding voltage test
- Calibration of low limit reference (LOWER REFERENCE) value of leakage current for withstanding voltage test
- Calibration of insulation resistance tester
- Calibration of waiting-time for judgement for insulation resistance test
- Calibration of GOOD signal generating period

(1) Instruments Required for Calibration

① Voltmeter I

AC voltmeter, 0.5 - 5 kV, 50 - 60 Hz, accuracy 1%.
(Kikusui Model 149-10A or an equivalent)

② Voltmeter II

DC voltmeter, 0.5 - 1.1 kV, input resistance $\geq 1000 \text{ M}\Omega$,
accuracy 1%. (Kikusui Model 149-10A or an equivalent)

③ Voltmeter III

DC voltmeter, 1.0 - 2.5 V, accuracy 0.1%

④ Load Resistors with Milliammeter

AC Ammeter, 0.5 - 100 mA (50 - 60 Hz) at test voltage 1000 V (800 V) with an accuracy of 1%. (kikusui Model TOS1200 or equivalents)

⑤ Standard Resistors

To calibrate insulation resistance tester. 1 M Ω - 2000 M Ω , decade type, voltage rating \geq 1100 V, accuracy 1%.

⑥ Oscilloscope

When ④ "Load Resistors with Milliammeter" are unavailable, a milliammeter and load resistors (ones for points not calibrated may be omitted) may be used instead.

o Milliammeter

AC milliammeter, 0.25 - 100 mA, 50 - 60 Hz, accuracy 1%

o Load Resistors

Voltage rating \geq 1.1 kV AC, accuracy 5%.

Use the resistance with enough greater wattages than shown in Table 6.1.

Table 6.1

Current [mA]	Load Resistance	
	Resistance [Ω]	Power consumptions [W]
*0.25	4M	0.25
0.5	2M	0.5
1	1M	1
2	500k	2
4	250k	4
*5	200k	5
8	125k	8
10	100k	10
*50	20k	50
100	10k	100

*: The values marked with the asterisks are for calibration of low limit reference (LOWER REFERENCE) values of leakage current.

895344

(2) Preparation for Calibration

- ① Before turning on the POWER switch, adjust the mechanical zero position of indicating meters.
- ② Turn on the POWER switch and allow a stabilization period of 15 minutes or more.
- ③ For layouts of components on PCB's, see Figures 6.5 and 6.6.

(3) Calibration of Output Voltmeter of Withstanding Voltage Tester

① Set the panel switches as follows:

- FUNCTION switch: MANUAL W
- RANGE 2.5kV/5kV switch: 2.5kV
- TIMER ON/OFF switch: OFF
- LOWER ON/OFF switch: OFF
- TEST VOLTAGE dial: Fully counterclockwise ("0" position)

- ② Connect voltmeter I to the output terminal. Set the Tester to the TEST ON state and adjust the output voltage so that the voltmeter reads 2.5 kV.
- ③ Adjust RV103 so that the Tester voltmeter pointer deflects to the center of the 2.5 kV scale.
- ④ Reduce the output voltage to zero. Change the RANGE 2.5kV/5kV switch to the 5 kV range.
- ⑤ Calibrate the 5 kV range with RV104 in a similar manner as the 2.5 kV range is calibrated with RV103. After the calibration is over, turn the TEST VOLTAGE dial to the fully counterclockwise position ("0" position) and press the RESET button.
- ⑥ Acquire data of the required test points.

(4) Calibration of High Limit (CUTOFF CURRENT) Value of Leakage Current for Withstanding Voltage Test

Measure the voltage of TP110 with reference to TP112, with voltmeter III. Adjust RV101 so that the voltmeter reads 2.318 V \pm 0.2%.

895345

(5) Check of High Limit (CUTOFF CURRENT) Value of Leakage Current for Withstanding Voltage Test

- ① Only with the calibration of Item (4) above, the high limit reference value satisfies the specified judging accuracy. If it does not, the Tester is malfunctioning.
- ② Set the panel switches of the Tester as mentioned in Item (3) ①. Select the required high limit reference value of leakage current with the CUTOFF CURRENT switches.
- ③ Prepare a test setup using load resistors with milliammeter (Kikusui Model TOS1200) or using load resistors appropriate for CUTOFF CURRENT switches and an AC milliammeter, as shown in Figure 6.1 or 6.2. For the resistances of the load resistors, see Table 6.1.

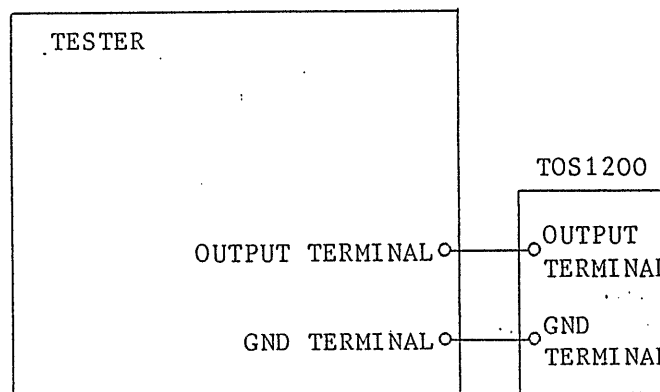

Figure 6.1

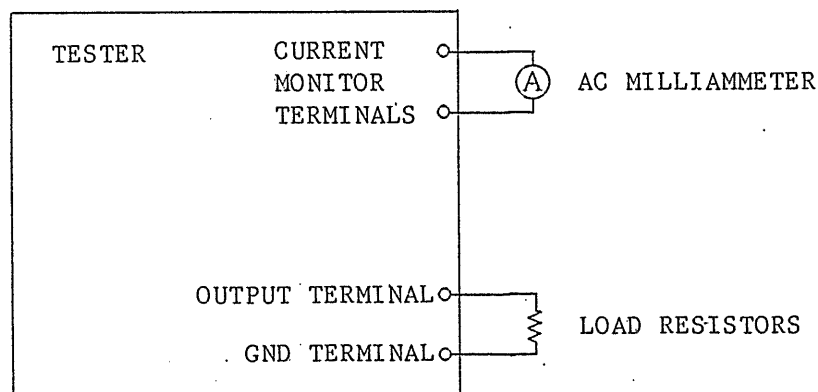

Figure 6.2

- ④ Set the Tester to the TEST ON state and gradually increase the output voltage. The Tester will generate an NG alarm at approximately 1 kV. Slightly turn counterclockwise the TEST VOLTAGE dial and set again the Tester to the TEST ON state.

895346

- ⑤ Increasing the output voltage very slowly, read the value of the current immediately before an NG alarm is generated and the output is cutoff.
 - ⑥ Repeat the procedure of ③ - ⑤ for individual high limit reference value (CUTOFF CURRENT) as required.
- (6) Calibration of Low Limit (LOWER REFERENCE) Value of Leakage Current for Withstanding Voltage Test
- ① Turn the LOWER REFERENCE control potentiometer to the fully clockwise position.
 - ② Measure the voltage of TP111 with reference to TP112, with voltmeter III. Adjust RV102 so that the voltmeter reads 1.092 V \pm 0.2%.
- (7) Check of Low Limit Reference (LOWER REFERENCE) Value of Leakage Current for Withstanding Voltage Test.
- ① Only with the calibration of Item (6) above, the low limit reference value satisfies the specified judging accuracy. If it does not, the Tester is malfunctioning
 - ② Set the panel switches of the Tester as mentioned in Item (3) ①. Select the required low limit reference value with the CUTOFF CURRENT switches.
 - ③ Turn the LOWER REFERENCE potentiometer fully clockwise. As you do this, the low limit reference value is set at one-half of the high limit reference value set in Step ② above.
 - ④ Prepare a test setup using resistors with milliammeter (Kikusui Model TOS1200) or using load resistors appropriate for low limit reference value and an AC milliammeter, as shown in Figure 6.1 or 6.2. For the resistances of the load resistors, see Table 6.1.
 - ⑤ Set the Tester to the TEST ON state and gradually increase the output voltage to a point (approximately 1.1 kV) where the current becomes greater than the set low limit reference value by approximately +10%. (Keep the LOWER ON/OFF switch in the OFF state.)

- ⑥ Turn the LOWER ON/OFF switch to the ON state.
- ⑦ Gradually decrease the output voltage. The Tester will generate an NG alarm at appropriately 1 kV of output voltage. Slightly turn clockwise the TEST VOLTAGE dial. Set the Tester again to the TEST ON state.
- ⑧ Decreasing the output voltage very slowly, read the value immediately before an NG alarm is generated and the output is cutoff.
- ⑨ Repeat the procedure of ④ - ⑧ for individual leakage current values as required.

(8) Calibration of Insulation Resistance Tester

① Calibration of output voltage

(a) Set the panel switches of the Tester as follows:

- | | |
|------------------------------|----------|
| ○ FUNCTION: | MANUAL I |
| ○ I TEST VOLTAGE 500V/1000V: | 1000V |
| ○ TIMER ON/OFF: | OFF |
| ○ JUDGE ON/OFF: | OFF |

(b) Connect voltmeter II to the output terminals. Set the Tester to the TEST ON state. Adjust RV203 so that voltmeter II reads -1025 V. After the adjustment is over, press the RESET button.

(c) Change the I TEST VOLTAGE 500V/1000V switches to 500V.

(d) Adjust RV204 so that voltmeter II reads -513 V.

② The Tester has two test voltage scale ranges. Calibrate it for the one which is used more frequently in your tests. When one range is calibrated, the other range also is calibrated automatically. The resistance values enclosed in the parentheses in Steps ⑤ and ⑥ below are for the 500 V range.

③ Set the panel switches of the Tester as in the case of Step ① above.

895348

- ④ Without connecting anything to the output terminals, set the Tester to the TEST ON state. Adjust RV205 (∞ ADJ) so that the meter indicates the " ∞ " position of the scale. After the adjustment is over, press the RESET button.
 - ⑤ Connect a standard resistor 2 M Ω (1 M Ω) to the output terminals. Set the Tester to the TEST ON state. Adjust the Zero ADJ on the front panel so that the meter reads 2 M Ω (1 M Ω). After the adjustment is over, press the RESET button.
 - ⑥ Replace the resistor of the output terminal with a resistor of 100 M Ω (50 M Ω). Set the Tester to the TEST ON state. Adjust RV206 so that the meter reads 100 M Ω (50 M Ω).
 - ⑦ Repeat the procedure of ⑤ and ⑥ for several times, and then repeat the procedure of ④.
 - ⑧ Short the output terminal. Set the Tester to the TEST ON state. Adjust RV202 so that the meter indicates the "0" scale position.
- (9) Calibration of Waiting-time for Judgement for Insulation Resistance Test

① Set the panel switches as follows:

- FUNCTION: MANUAL I
- TIMER ON/OFF: OFF
- JUDGE ON/OFF: ON

② Without connecting anything to the output terminals, set the Tester to the TEST ON state. When doing this, measure the time interval (T1) at TP106 and adjust RV106 so that the time interval becomes 0.3 sec.

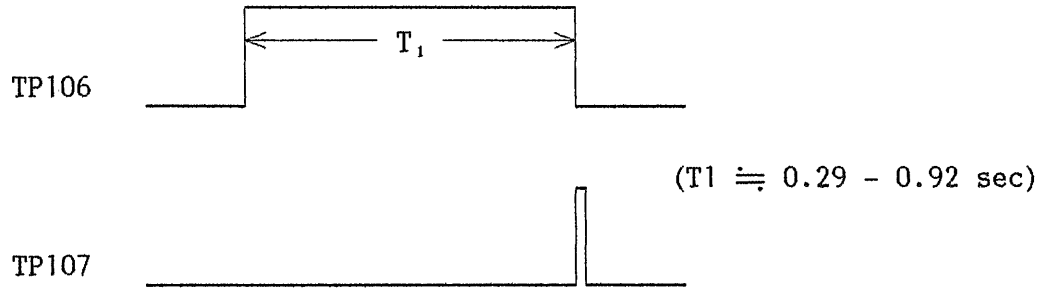

Figure 6.3

(10) Calibration of GOOD Signal Generating period

① Set the panel switches as follows:

- FUNCTION: MANUAL I
- TIMER ON/OFF ON
- JUDGE ON/OFF OFF
- I TIMER: $\geq 1 \text{ sec}$

② Without connecting anything to the output terminal, set the Tester to the the TEST ON state. When doing this, measure the time interval (T_2) at TP109 and adjust RV107 so that the time interval becomes 50 msec.



Figure 6.4

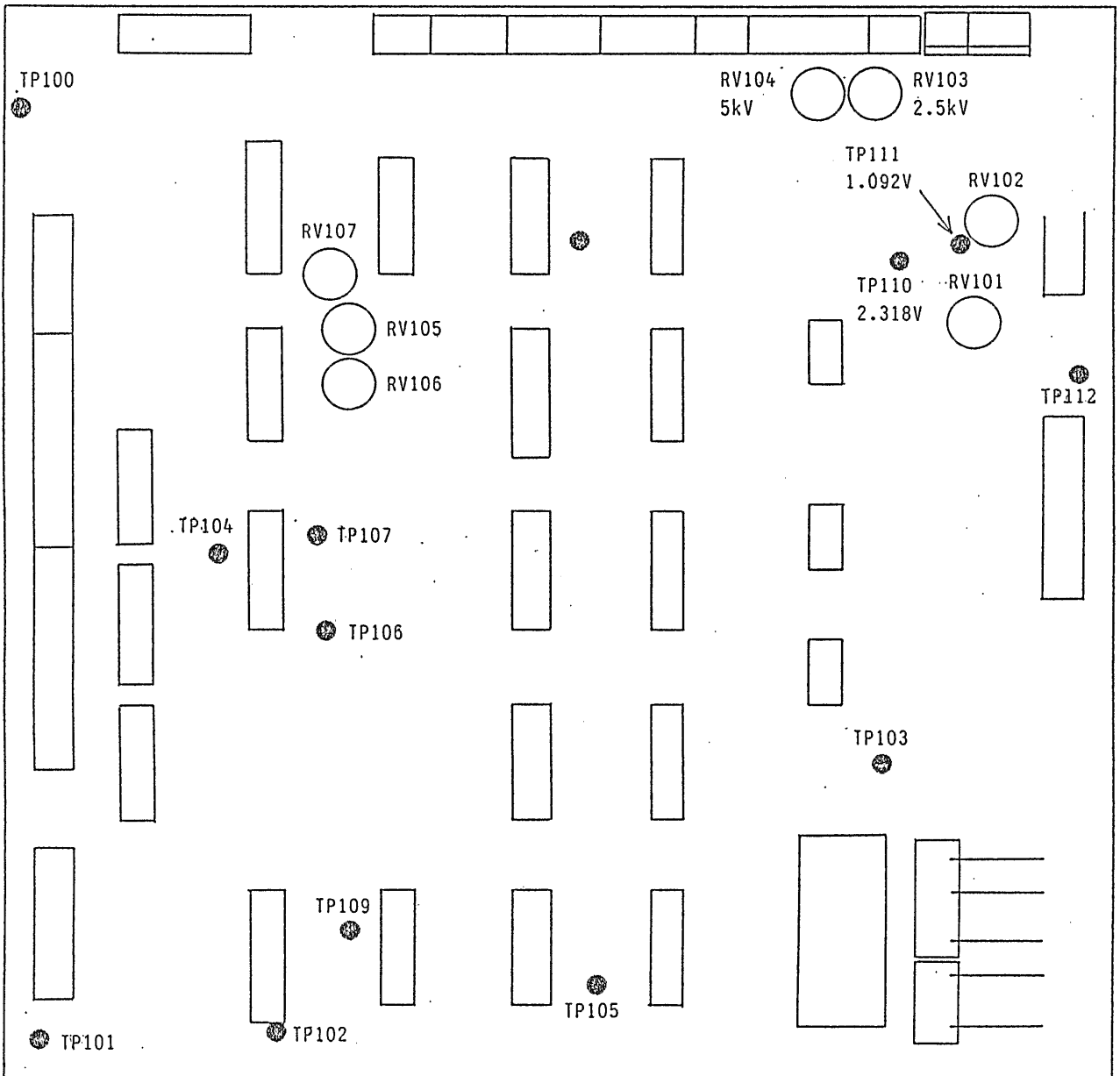

Figure 6.5 Layout of Components on PCB A1

This PCB is located at a left-hand position inside of the Tester.

895351

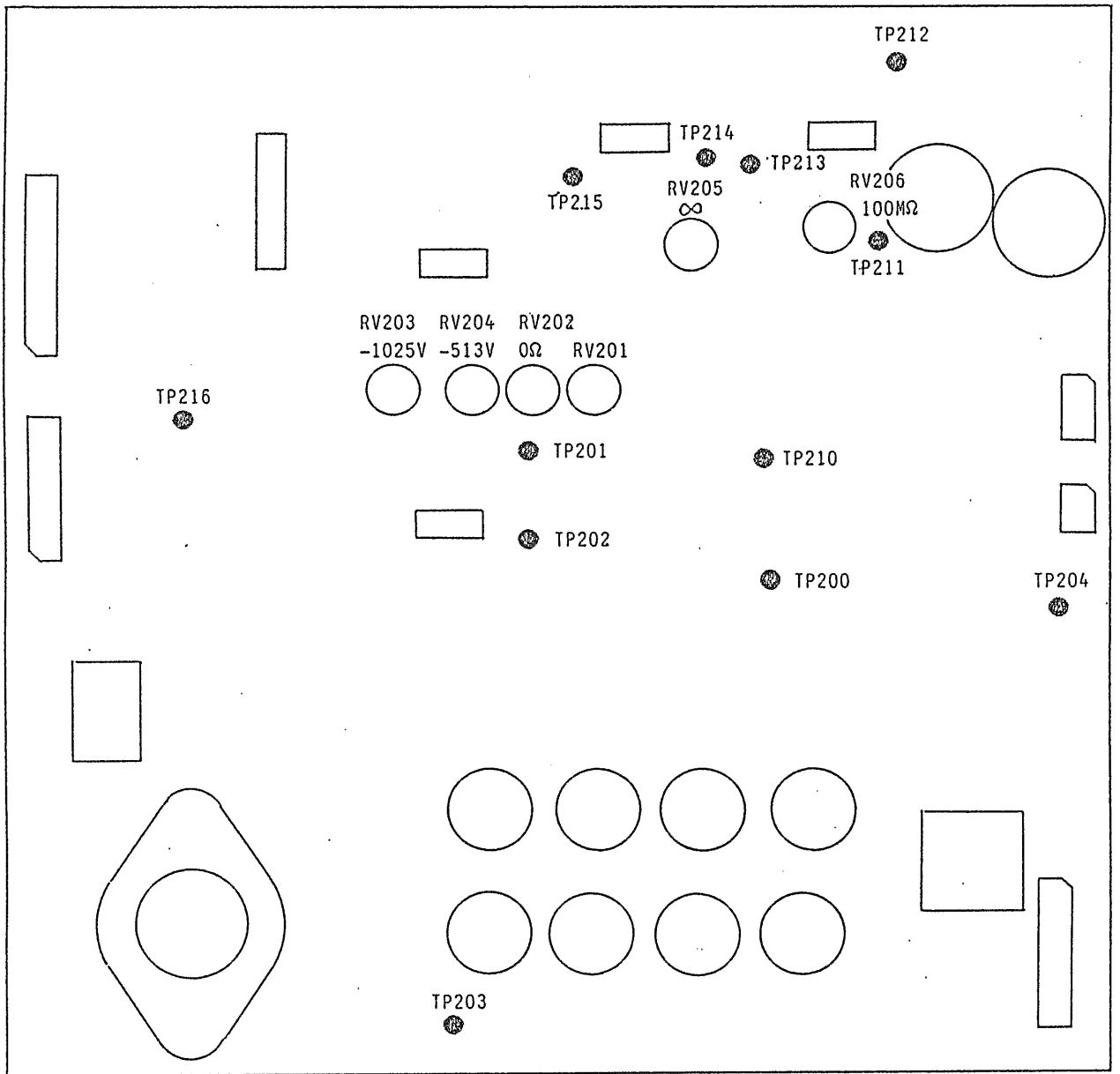

Figure 6.6 Layout of Components on PCB A2

This PCB is located at a right-hand position inside of the Tester.

7.OPTION

Model RC01-TOS/RC02-TOS Remote Control Box

Model RC01-TOS or RC02-TOS Remote Control Box is for remote control of start/stop of test operation of the Tester. For remote control, connect the Control Box to the REMOTE connector on the front panel of the Tester. The RC01-TOS has one START switch; RC02-TOS has two START switches and the test starts as you press both switches at the same time with your both hands, thereby enhancing the operating safety.

Functions fo switches:

OPERATE switch: This switch enables (when ON) or disables the START switch or switches.

START switch : The test starts as you press this switch (or switches) when the OPERATE switch is ON and the Tester is in the READY status.

STOP switch : This switch terminates the test (cuts off the test voltage or resets the Tester from the FAIL or other particular status—its functions are the same with those of the STOP switch on the front panel of the Tester.

Dimensions

RC01-TOS: 200W×70H×39Dmm (7.9W×2.8H×1.5D in)

RC02-TOS: 330W×70H×39Dmm (13W×2.8H×1.5D in)

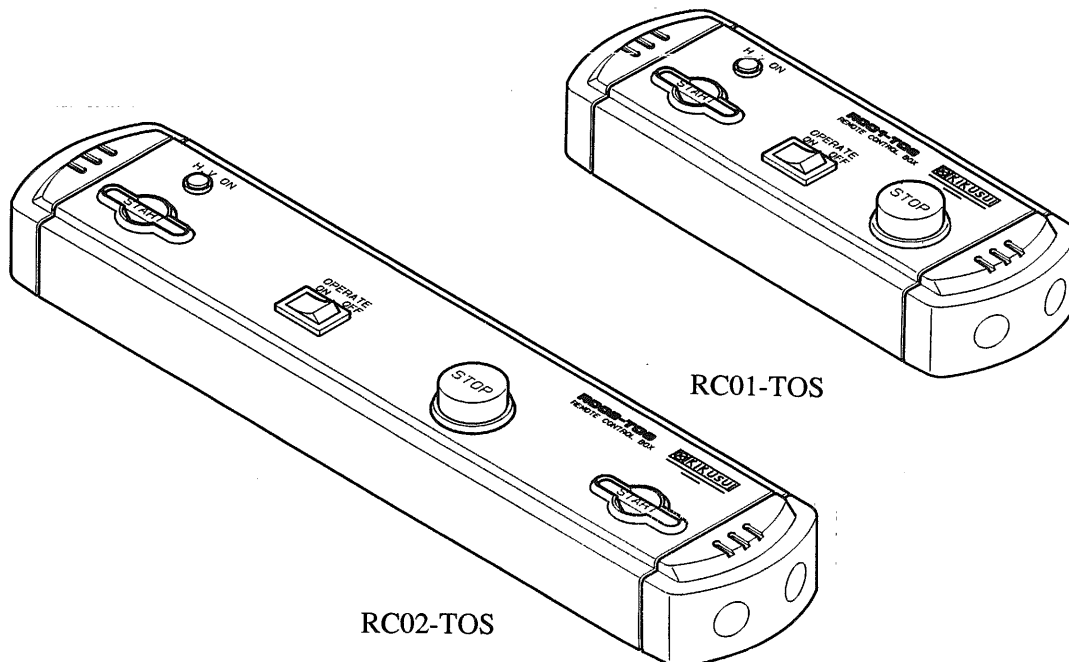

Model HA01A-TOS/HA02A-TOS High Voltage Test Probe

The High Voltage Test Probe renders a three-fold operating safety. namely, the test voltage is not delivered unless you squeeze with one hand the slide lever of the grip of the probe and pull the probe and pull the trigger and you press with the other hand the switch on top of the probe, thereby occupying your both hands. As you release even a single one of these, the probe immediately and forcefully delivers the STOP signal to cut off the test voltage.

Voltage ratings: 4kV(rms)AC,50/60Hz;
5kV DC

Length of cable: Appropx. 1.8m(HP01A-TOS)
Appropx. 1.8m(HP01A-TOS)

WARNING: · The maximum voltage ratings of the probe is 4kV rms AC or 5kV DC. Never let it subjected to voltages higher than these limits.

· Do not connect the probe to or disconnect it from the DUT while letting it deliver the test voltage-if you do this, the DUT may be damaged. If you disconnect the probe from the DUT while letting it deliver the test voltage, the items of the tested circuit may remain charged up to the high test voltage. Before connecting the probe to the DUT, be sure that the test voltage is OFF(the LED on top of the probe is OFF);before disconnecting the probe from the DUT, be sure that the test voltage is OFF(the LED is OFF).

CAUTION: · If you need a test in compliance to the UL Standard by using the probe, set the FAIL MODE switch(DIP switch on the rear panel)of the Tester to ON. If you have set this switch to ON, the Tester is not reset from the FAIL status has gone out or PROTECTION status even when you have released your hand from the probe. To reset it, you have to press the stop switch of the Tester. Thus, you will be securely informed of the FAIL judgement.

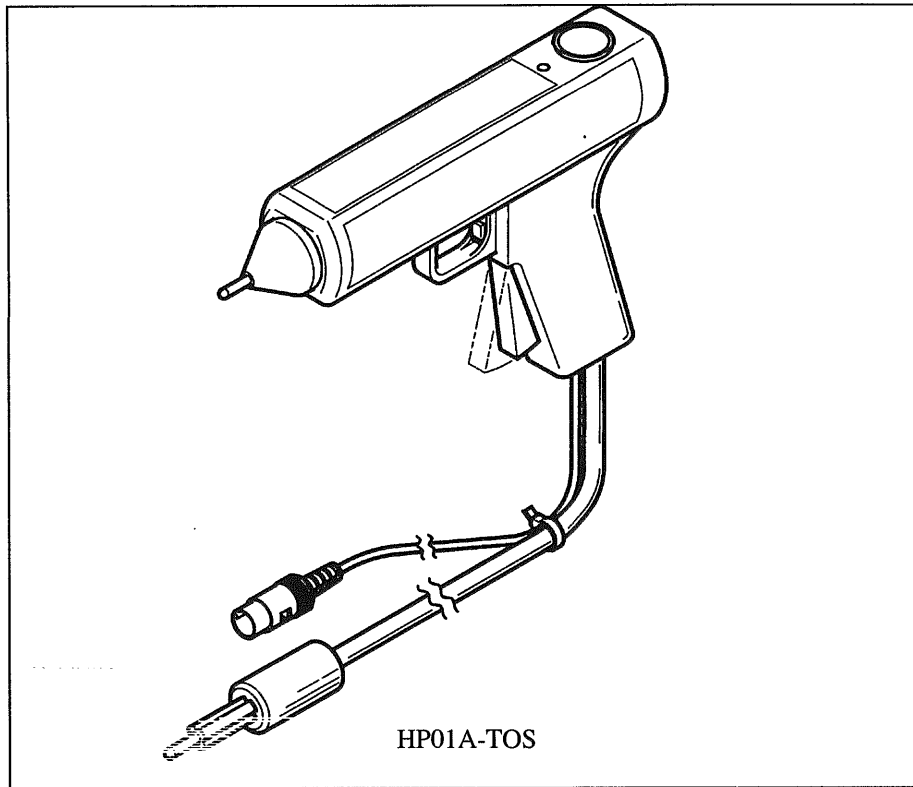

HP01A-TOS

- MODEL PL01-TOS Warning Light Unit : This unit indicates that the Tester is in the TEST-ON status (delivering the test voltage).
- MODEL BZ01-TOS Buzzer Unit : This unit may be used when the sound generated by the buzzer housed in the Tester is insufficient. This unit can be driven by the FAIL status signal of the tester.
- High Voltage Test Leadwires

Model	Voltage rating	Length
TL01-TOS	AC:5kV rms,50/60Hz DC:5kV	Approx. 1.5m
TL02-TOS	AC:5kV rms,50/60Hz DC:5kV	Approx. 3.0m

- BH4M-TOS Rack Mount Brackets (JIS type) : The brackets are used to install the W/I Tester on an instrument rack of JIS Standard. (unit:mm)
- BH5-TOS Rack Mount Brackets (EIA type) : The brackets are used to install the W/I Tester on an instrument rack of EIA Standard. (unit:inch)