

Megger.

Programma

TOR KEL 840/860 Battery Load Units

Programma TOR KEL 840/860 Battery Load Units



- Batteries can be tested "in service"
- Unit adjusts to include load currents in the test parameters
- User adjustable alarm and shutdown points to avoid excessive discharge
- Easily expandable for larger battery banks using TXL extra load units
- View test parameters/results "real time" as testing progresses using TOR KEL WIN software
- Easily save results to a PC for analysis, report generation and storage

DESCRIPTION

TOR KEL® 840 - UTILITY is used for battery systems ranging from 12 to 250 V – often encountered in switchgear and similar equipment. Discharging can take place at up to 110 A, and if higher current is needed, two or more TOR KEL 840 units, or extra load units (TXL), can be linked together. Tests can be conducted at constant current, constant power, constant resistance or in accordance with a pre-selected load profile.

TOR KEL 860 - MULTI is designed primarily for people who travel from place to place to maintain battery systems having different voltages. It features excellent discharging capacity plus a broad voltage range and outstanding portability – a unique combination.

The TOR KEL 860 is used for systems ranging from 12 to 480 V, and discharging can proceed at up to 110 A. If higher current is desired, two or more TOR KEL 860 units, or extra load units (TXL), can be linked together. Discharging can take place at constant current, constant output, constant resistance or in accordance with a pre-selected load profile.

APPLICATION

Batteries in power plants and transformer substations must provide the equipment they serve with standby power in the event of a power failure. Unfortunately, however, the capacity of such batteries can drop significantly for a number of reasons before their calculated life expectancy is reached. This is why it is so important to check batteries at regular intervals, and the only reliable way of measuring battery capacity is to conduct a discharge test.

Application examples with TOR KEL/TXL systems

TOR KEL and TXL can be combined into systems to match different battery capacities. Below are two examples. Other combinations can be found in the section called TOR KEL/TXL System examples.

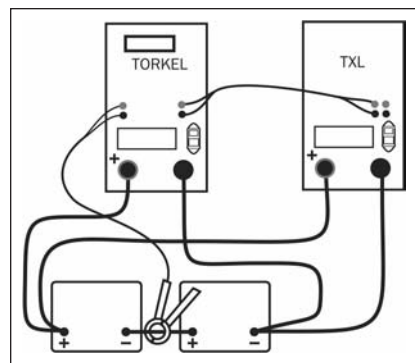

TOR KEL and the extra load TXL unit

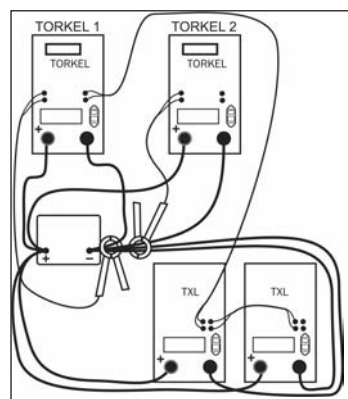

Example of multiple TOR KEL and TXL arrangement

FEATURES AND BENEFITS

- Batteries can be tested “in service”. TORHEL will adjust to include the load current in the test parameters.
- User adjustable alarm and shutdown points to avoid excessive discharge.
- No loss of test data in the event of a power loss during testing.
- Easily expandable for larger battery banks using TXL extra load units.
- Can be used “stand alone” or with a PC running TORHEL WIN Software.

SPECIFICATIONS

Specifications are valid at nominal input voltage and an ambient temperature of +25° C, (77° F). Specifications are subject to change without notice.

Environment

Application field

The instrument is intended for use in high-voltage substations and industrial environments.

Temperature

Operating	0° C to +40° C (32° F to +104° F)
Storage & transport	-40° C to +70° C (-40° F to +158° F)
Humidity	5% – 95% RH, non-condensing

CE-marking

Safety standards	IEC 61010-1:2001 Incl. national dev. for US and CAEN 61010-1:2001
EMC standards	EN 61326: 1997+A1:1998+A2:2001

General

Power supply voltage	100 – 240 V AC, 50/60 Hz
Power consumption (max)	150 W
Protection	Thermal cut-outs, automatic overload protection

Dimensions

Instrument	210 x 353 x 700 mm (8.3" x 13.9" x 27.6")
Transport case	265 x 460 x 750 mm (10.4" x 18.1" x 29.5")
Weight	21.5 kg (47.4 lbs) 38 kg (83.8 lbs) with accessories and transport case.
Display	LCD
Available languages	English, French, German, Spanish, Swedish

Measurement section

Current measurement

Display range	0.0 – 2999 A
Accuracy	±(0.5% of reading +0.2 A)
Resolution	0.1 A

Internal current measurement

Range	0 – 270 A
-------	-----------

Input for clamp-on ammeter

Range	0 – 1 V
mV/A-ratio	Software settable, 0.3 to 19.9 mV/A
Input impedance	>1 MΩ

Voltage measurement

Display range 0.0 – 60 V

Accuracy	±(0.5% of reading +0.1 V)
Resolution	0.1 V

Display range 0.0 – 500 V

Accuracy	±(0.5% of reading +1 V)
Resolution	0.1 V

Time measurement

Accuracy	±0.1% of reading ±1 digit
----------	---------------------------

Load section

Max. battery voltage	288 V DC (TORHEL 840) 480 V DC (TORHEL 860)
Max. current	110 A
Max. power	15 kW
Load patterns	Constant current, constant power, constant resistance, current or power profile
Current setting	0-110.0 A (2999.9 A) ¹
Power setting	0-15.00 kW (299.99 kW) ¹
Resistance setting	0.1-2999.8Ω
Battery voltage range, TORHEL 840	4 ranges, selected automatically at start of test
Battery voltage range, TORHEL 860	5 ranges, selected automatically at start of test
Stabilization (For internal current measurement)	±(0.5% of reading +0.5 A)

	Battery voltage	Highest permissible current	Resistor element (Nominal values)
Range 1	10 – 27.6 V	110 A	0.165 Ω
Range 2	10 – 55.2 V	110 A	0.275 Ω
Range 3	10 – 144 V	110 A	0.55 Ω
Range 4	10 – 288 V	55 A	3.3 Ω
Range 5 ²	10 – 480 V	55 A (max power 15 kW)	3.3 Ω

1) Maximum value for a system with more than one load unit

2) TORHEL 860

Inputs, maximum values

External current measurement	1 V DC, 300 V DC to ground. Current shunt should be connected to the negative side of the battery
Start/Stop	Momentary closure starts a test. Momentary closure stops a test.
Delay until start	200 – 300 ms
Stop delay	100 – 200 ms
Battery	480 V DC, 500 V DC to ground
Voltage sense	480 V DC, 500 V DC to ground
Serial	< 15 V
Alarm	250 V DC 0.28 A 28 V DC 8 A 250 V AC 8 A

Outputs, maximum values

Start/Stop	5 V, 6 mA
TXL	Relay contact
Serial	< 15 V
Alarm	Relay contact

Discharging capacity examples

12 V battery (6 cells)³

Final voltage	Constant current	Constant power
1.80 V/cell (10.8 V)	0 – 50.0 A	0 – 0.54 kW
1.75 V/cell (10.5 V)	0 – 49.0 A	0 – 0.51 kW
1.67 V/cell (10.0 V)	0 – 46.0 A	0 – 0.46 kW

24 V battery (12 cells)³

1.80 V/cell (21.6 V)	0 – 110 A	0 – 2.37 kW
1.75 V/cell (21.0 V)	0 – 110 A	0 – 2.31 kW
1.60 V/cell (19.2 V)	0 – 100 A	0 – 1.92 kW

48 V battery (24 cells)³

1.80 V/cell (43.2 V)	0 – 110 A	0 – 4.75 kW
1.75 V/cell (42.0 V)	0 – 110 A	0 – 4.62 kW
1.60 V/cell (38.4 V)	0 – 110 A	0 – 4.22 kW

110 V battery (54 cells)³

1.80 V/cell (97.2 V)	0 – 110 A	0 – 10.7 kW
1.75 V/cell (94.5 V)	0 – 110 A	0 – 10.4 kW
1.60 V/cell (86.4 V)	0 – 110 A	0 – 9.5 kW

120 V battery (60 cells)³

1.80 V/cell (108 V)	0 – 110 A	0 – 11.9 kW
1.75 V/cell (105 V)	0 – 110 A	0 – 11.5 kW
1.60 V/cell (96 V)	0 – 110 A	0 – 10.5 kW

220 V battery (108 cells)³

1.80 V/cell (194 V)	0 – 55 A	0 – 10.7 kW
1.75 V/cell (189 V)	0 – 55 A	0 – 10.4 kW
1.60 V/cell (173 V)	0 – 51.0 A	0 – 8.82 kW

240 V battery (120 cells)³

1.80 V/cell (216 V)	0 – 55 A	0 – 11.9 kW
1.75 V/cell (210 V)	0 – 55 A	0 – 11.5 kW
1.60 V/cell (192 V)	0 – 55 A	0 – 10.5 kW

UPS battery (180 cells)³ (TORHEL 860)

1.70 V/cell (306 V)	0 – 38 A	0 – 15 kW
1.60 V/cell (288 V)	0 – 38 A	0 – 15 kW

UPS battery (204 cells)³ (TORHEL 860)

1.80 V/cell (367 V)	0 – 34 A	0 – 15 kW
1.60 V/cell (326 V)	0 – 34 A	0 – 15 kW

3) 2.15 V per cell when test starts

Environment

Application field	The instrument is intended for use in high-voltage substations and industrial environments.
-------------------	---

Temperature

Operating	0° C to +40° C (32° F to +104° F)
Storage & transport	-40° C to +70° C (-40° F to +158° F)
Humidity	5% – 95% RH, non-condensing

CE-marking

Safety standards	IEC 61010-1:2001 Incl. national dev. for US and CAEN 61010-1:2001
EMC standards	EN 61326: 1997+A1:1998+A2:2001

General

Power supply voltage	100 – 240 V AC, 50/60 Hz
Power consumption	75 W (max)
Protection	Thermal cut-outs, automatic overload protection

Dimensions

Instrument	210 x 353 x 600 mm (8.3" x 13.9" x 23.6")
Transport case	265 x 460 x 750 mm (10.4" x 18.1" x 29.5")
Weight	13 kg (28.7 lbs) 21.4 kg (47.2 lbs) with transport case

Cable sets

for TXL830/850	2 x 3 m (9.8 ft), 70 mm ² , 270 A, with cable lug. Max. 100 V. 5 kg (11 lbs)
for TXL870	2 x 3 m (9.8 ft), 25 mm ² , 110 A, with cable clamp/lug. Max. 480 V. 3 kg (6.6 lbs)

Load section

	TXL830	TXL850	TXL870
Max. voltage (DC)	28 V	56 V	140 V/ 280 V
Max. current	300 A	300 A	112 A at 140 V 56 A at 280 V
Max. power	8.3 kW	16.4 kW	15.8 kW

Internal resistance, 3-position selector

Position 1	TXL830	TXL850	TXL870
Current	0.275 Ω	0.55 Ω	4.95 Ω
100 A	at 27.6 V	at 55.2 V	–
78.5 A	(12 x 2.3 V) at 21.6 V	(24 x 2.3 V) at 43.2 V	–
50.1 A	(12 x 1.8 V)	(24 x 1.8 V)	at 248.4 V (108 x 2.3 V)
39.2 A	–	–	at 194.4 V (108 x 1.8 V)
Position 2	TXL830	TXL850	TXL870
Current	0.138 Ω	0.275 Ω	2.48 Ω
200 A	at 27.6 V	at 55.2 V	–
156 A	at 21.6 V	(24 x 2.3 V) 43.2 V	–
		(24 x 1.8 V)	
Position 3	TXL830	TXL850	TXL870
Current	0.092 Ω	0.184 Ω	1.24 Ω
300 A	at 27.6 V	at 55.2 V	–
235 A	at 21.6 V	(24 x 2.3 V) 43.2 A	–
		(24 x 1.8 V)	
100 A	–	–	at 124.2 V (54 x 2.3 V)
78.4 A	–	–	at 97.2 V (54 x 1.8 V)

TORCEL/TXL Systems – Examples

TORCEL 820 + TXL830, 12 V battery (6 cells)¹

Max. constant current (A)	Number of TORCEL-units	Number of TXL-units
234	1	1
571	1	4
918	2	6

TORCEL 820 + TXL830, 24 V battery (12 cells)¹

495	1	1
1170	1	4
1890	2	6

TORCEL 820 + TXL850, 48 V battery (24 cells)¹

499	1	1
1189	1	4
1918	2	6

TORCEL 840/860 + TXL830, 24 V battery (12 cells)¹

263	1	1
670	2	2
1005	3	3

TORCEL 840/860 + TXL850, 48 V battery (24 cells)¹

264	1	1
909	2	3

TORCEL 840/860 + TXL870, 110 V battery (54 cells)¹

188	1	1
532	2	4
845	2	8

TORCEL 840/860 + TXL870, 120 V battery (60 cells)²

194	1	1
557	2	4
895	2	8

TORCEL 840/860 + TXL870, 220 V battery (108 cells)¹

94	1	1
266	2	4
423	2	8

1) Discharge from 2.15 V to 1.8 V per cell

2) Discharge from 2.15 to 1.75 V per cell



Cable Set GA-00550

BATTERY TESTING ACCESSORIES

TORCEL Win

PC software

- Shows the complete voltage curve
- Last recorded time, voltage, current and discharged capacity
- Scroll-window for all recorded values
- Remote control of TORCEL
- Report functions

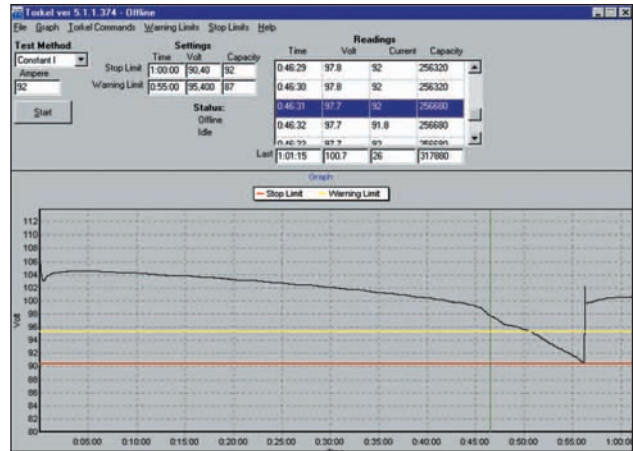

TORCEL Win showing total voltage curve

TXL units

- Extra loads
- These resistive extra loads do not perform any regulating functions.
- They are designed for use together with TORCEL Battery Load Units.
- Their purpose is to provide higher load currents for use in constant current or constant power tests. Together, TORCEL and the TXL Extra Loads form a system that can discharge batteries with currents of up to several kA. TXL Extra Loads are connected directly to the battery, and TORCEL measures the total current using a clamp-on ammeter.
- TXL Extra Loads are shut down automatically when TORCEL is stopped.



TXL870

ORDERING INFORMATION

Item (Qty)	Cat. No.
TORCEL840 complete with cable set GA-00550 and transport case GD-00054	BS-49094
TORCEL860 complete with cable set GA-00550 and transport case GD-00054	BS-49096
TXL850 is intended for 48 V systems. Complete with cable set GA-00554 and transport case GD-00054. A DC clamp-on ammeter must be used to enable TORCEL 850 to measure the total current.	BS-59095
TXL870 is intended primarily for 125 and 240 V battery systems. Complete with cable set GA-00550 and transport case GD-00054. A DC clamp-on ammeter must be used to enable TORCEL 870 to measure the total current.	BS-59097
Cable sets	
Cable set for TXL830 and TXL850 2 x 3 m, 70 mm ² , with cable lug. Max 100 V 270 A. Weight: 5.0 kg (11 lbs)	GA-00554
Extension cable set, 110 A 2 x 3 m, 25 mm ² . Max 480 V. Weight: 3.0 kg (6.6 lbs)	GA-00552
Sensing lead set for measuring voltage at battery terminals. 2 x 5 m (16.4 ft)	GA-00210
DC clamp-on ammeter, 200 A to measure current in circuit outside TORCEL	XA-12992
DC clamp-on ammeter, 1000 A to measure current in circuit outside TORCEL	XA-12990
Optional accessories	
TORCEL Win	BS-8208X
See battery testing Accessories	

UK
Archcliffe Road, Dover
CT17 9EN England
T +44 (0) 1 304 502101
F +44 (0) 1 304 207342
UKsales@megger.com

UNITED STATES
4271 Bronze Way
Dallas, TX 75237-1019 USA
T 1 800 723 2861 (USA only)
T +1 214 333 3201
F +1 214 331 7399
USsales@megger.com

OTHER TECHNICAL SALES OFFICES
Täby SWEDEN, Norristown USA,
Sydney AUSTRALIA, Toronto CANADA,
Trappes FRANCE, Kingdom of BAHRAIN,
Mumbai INDIA, Johannesburg SOUTH
AFRICA, and Chonburi THAILAND

Registered to ISO 9001:2000 and
ISO 14001:2004
Cert. no. GBG0005937

TORCEL840_DS_en_V01
www.megger.com
Megger is a registered trademark