

**Agilent E5810 LAN/GPIB Gateway**  
**Agilent E5818 LXI Class-B Trigger Box**

**Rack Mount Installation Note**

One rack mount kit contains the hardware to mount a single E5810/E5818 or two E5810s/E5818s, side-by-side.

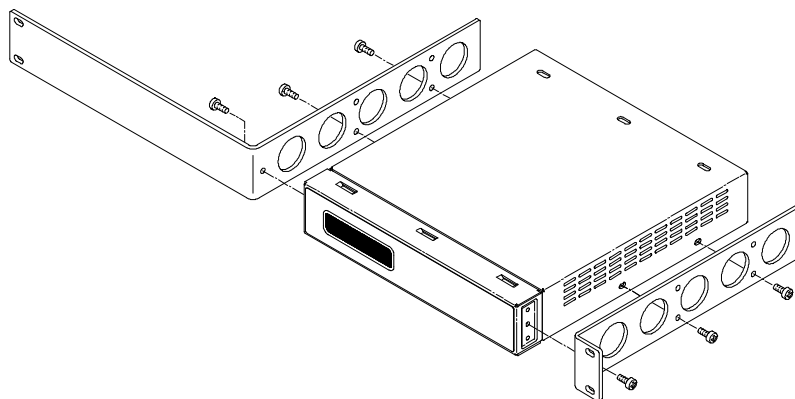

This rack mount is suitable for both E5810 and E5818 units.

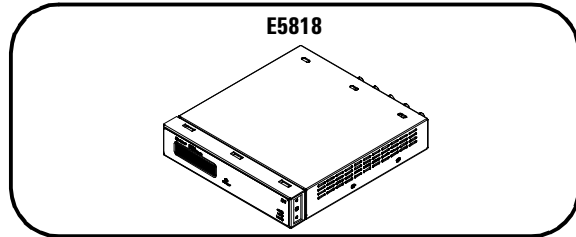
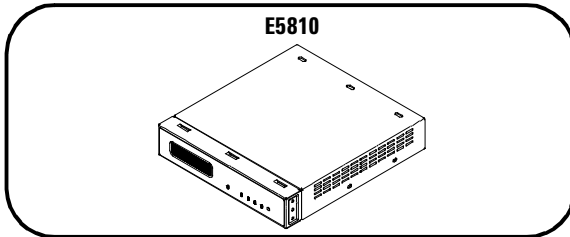

### Rack Mounting Single E5810/E5818 (see other side to rack mount two E5810s/E5818s)

Parts needed to install a single E5810/E5818 in a rack:

<b>A</b>	E5810-00021	Rack Ear - Full Pack	1	<b>D</b>	0570-1581	Screw, Machine	4
<b>B</b>	E5810-00022	Rack Ear - Half Rack	1	<b>E</b>	0590-0804	Nut, Machine	4
<b>C</b>	0515-1114	Screw, Panhead, M4x10	6				

1. Remove both rubber bumpers from the E5810/E5818.

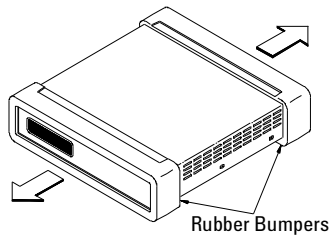

2. Using Pozidriv screwdriver, attach Rack Ear-Half Rack (B) to the E5810/E5818 with three M4x10 Panhead Screws (C).

3. Using Pozidriv screwdriver, attach Rack Ear-Full Rack (A) to the E5810/E5818 with three M4x10 Panhead Screws (C).

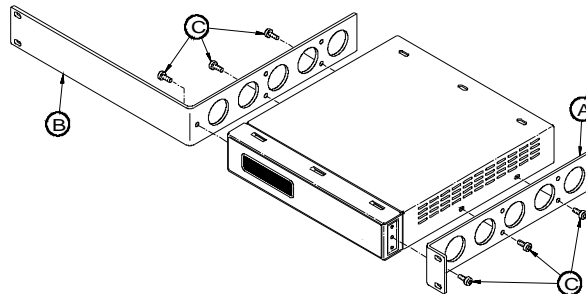

4. Do the connections based on the diagrams below:

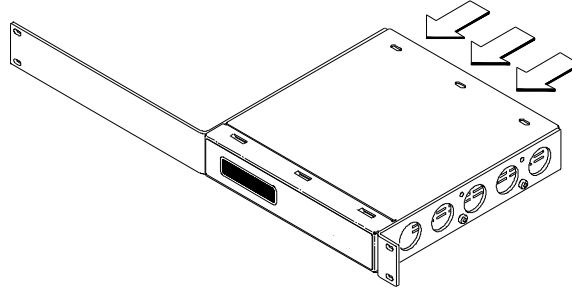

A. Rear View of the E5810

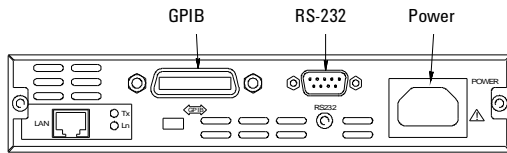

Connect GPIB and RS-232 cables. Plug AC Power cord into AC Power port on the E5810.

B. Rear View of the E5818

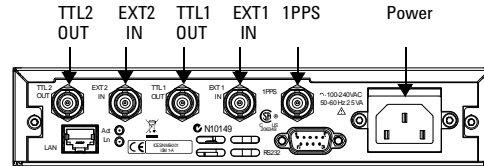

Connect BNC cables. Plug AC Power Cord into AC Power port and the E5818.

5. Using Philips screwdriver, attach Rack Ears to rack with four Machine Screws (D) and four Machine Nuts (E).

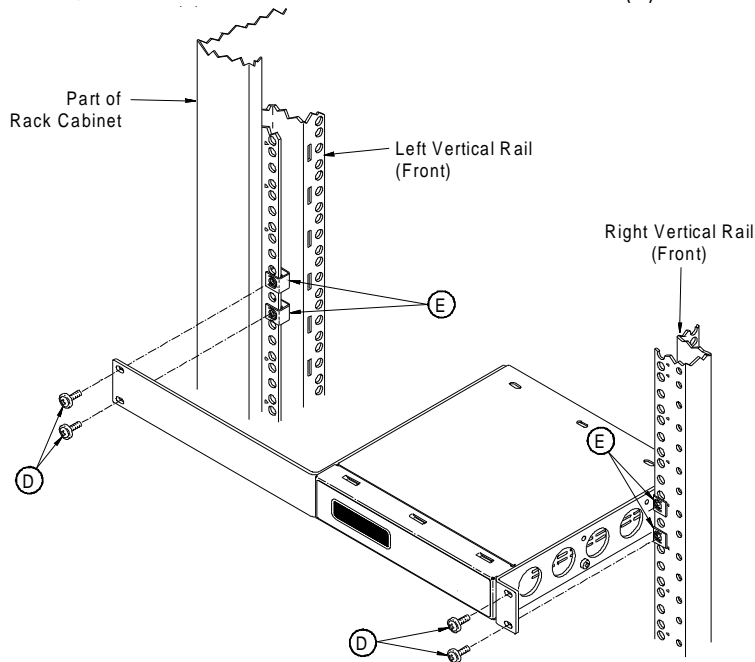

## Rack Mounting Two E5810s/E5818s (see other side to rack mount single E5810/E5818)

Parts needed to install two E5810s/E5818s, side-by-side, in a rack:							
<b>A</b>	0050-2166	Lock Link	2	<b>E</b>	0515-1367	Screw, Flathead, M4x8	2
<b>B</b>	E5810-00023	Bracket, Rear	1	<b>F</b>	0570-1581	Screw, Machine	4
<b>C</b>	E5810-00021	Rack Ear - Full Rack	2	<b>G</b>	0590-0804	Nut, Machine	4
<b>D</b>	0515-1114	Screw, Panhead, M4x10	6				

1. Remove both rubber bumpers from the E5810/E5818.

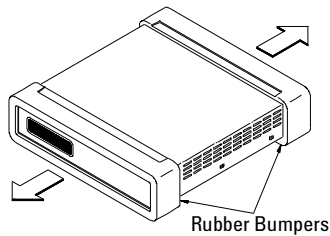

2. Using Pozidriv screwdriver, install a Lock Link (A) on each E5810/E5818 with a Flathead Screw (G). Then, slide the two E5810s/E5818s together so the Lock Links interconnect. See detail "A".

3. Using Pozidriv screwdriver, remove the screw at the rear of each E5810/E5818. Then, connect the Rear Bracket (B) to each E5810/E5818, using the screws you just removed.

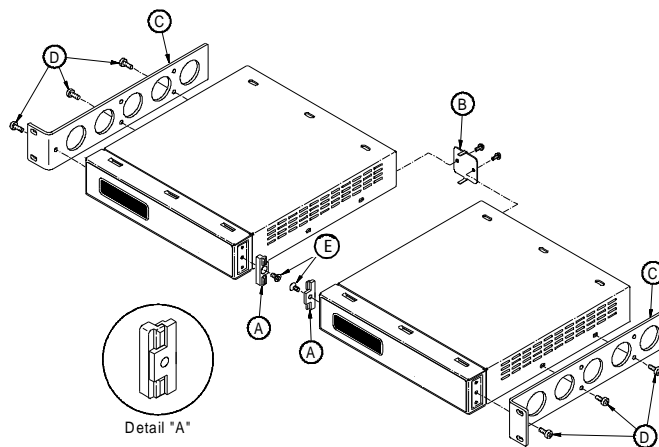

4. Using Pozidriv screwdriver, attach Rack Ear-Full Rack (C) to each E5810/E5818 with six M4x10 Panhead Screws (D).

5. Do the connections based on the diagrams below:

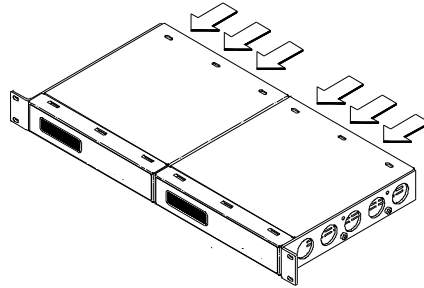

A. Rear View of the E5810

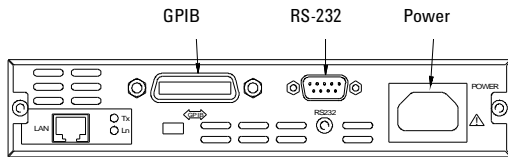

Connect GPIB and RS-232 cables. Plug AC Power cord into AC Power port on the E5810.

B. Rear View of the E5818

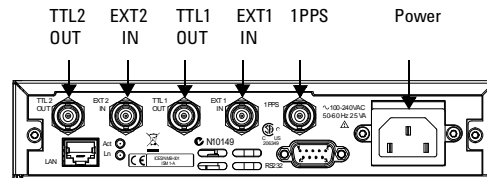

Connect BNC cables. Plug AC Power Cord into AC Power port and the E5818.

6. Using Philips screwdriver, attach Rack Ears to rack with four Machine Screws (F) and four Machine Nuts (G).

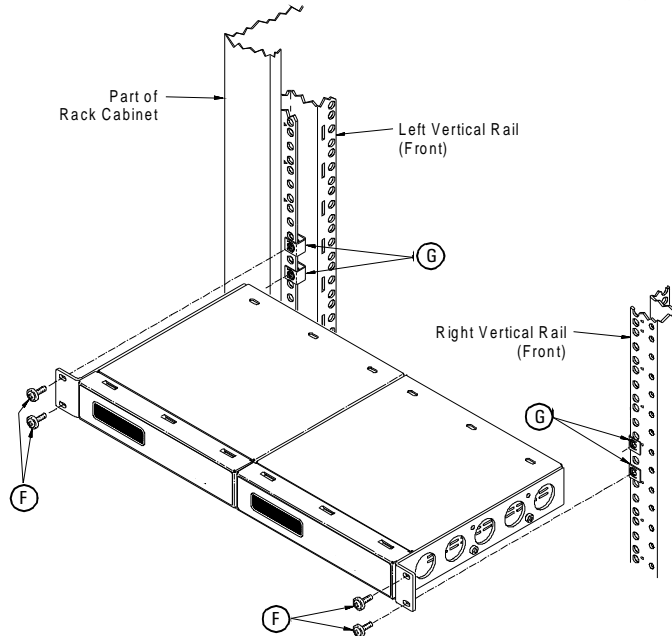

© Agilent Technologies, Inc. 2004 – 2008

Printed in Malaysia  
Third Edition, January 31, 2008



E5810-99100

