



Advanced Test Equipment Rentals
www.atecorp.com 800-404-ATEC (2832)

High voltage power supplies



The PS300 Series

Programmable high voltage supplies for laboratory and ATE applications

- 25 W output power
- 0.001% regulation
- 0.05 % accuracy
- Low output ripple
- Dual polarity
- Programmable voltage and current limits and trips
- Store and recall setups
- Full status display with voltage and current readouts
- Analog voltage programmable
- Optional IEEE-488 GPIB interface

The PS300 Series

Model	Output Voltage	Current
PS350	50 to ± 5.0 kV DC	5 mA
PS325	50 to ± 2.5 kVDC	10 mA
PS310	50 to ± 1.25 kVDC	20 mA

Introducing a new family of power supplies from Stanford Research Systems. The PS300 Series.

Rugged, compact programmable power supplies that fit just about any high voltage application.

And any budget.

Yet, even though the PS300 Series power supplies are priced economically, they outperform more expensive instruments and are loaded with features that make them more versatile and easier to use.

Choose from three models, with voltage to 5 kV and currents to 20 mA. All three have 25 Watts of output power with 0.001% regulation and 0.05% accuracy. And all of them are arc and short-circuit protected with separate, programmable hard and soft current limits, making it possible to use them as circuit breakers or constant current sources.

Whatever model you choose, you'll appreciate the convenience and versatility of the PS300 Series. Two LED displays monitor output voltage, current and polarity continuously. Overload reset, limit and trip status, local remote state, and high voltage enable are also displayed, so you can monitor instrument status at a glance.

Operation is simple, too.

The parameter being adjusted or set is displayed separately and can be entered without affecting the actual output voltage. Up to 9 settings can be stored and recalled, making it easy to run multiple tests. Parameters are chosen using a SELECT key and set using either the number keys or the cursor keys on the keypad.

Unless, of course, you want remote operation.

Then, an optional IEEE-488 GPIB interface makes it possible to program and set

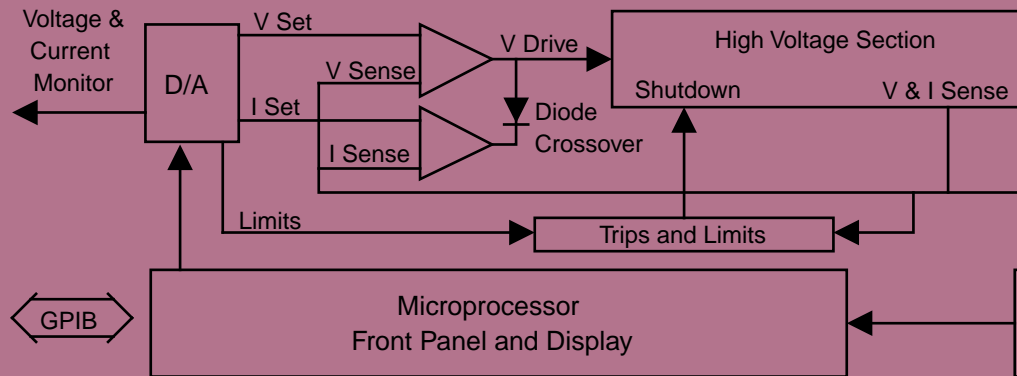

Operation

all PS300 Series operation modes remotely. All parameters can be set and read via the interface and Service Requests can be generated in response to overload or trip conditions. A rear panel switch allows the output voltage to be programmed by an analog input voltage and overrides both front panel and IEEE-488 programming.

All things considered, it's a lot to pack into a power supply that only measures 16" x 8" x 3.5"

But we wanted to make sure the PS300 Series works easily with your high voltage test procedures, analytical instruments, automatic test systems, and general laboratory applications.

To see exactly how well the PS300 Series fits your application, refer to the specifications on the back of this brochure. For further information, or to place an order, call Stanford Research Systems at (408) 744-9040.

Voltage and current displays provide 4 digit resolution plus polarity and can be read over the GPIB interface.

Overload response selects MANUAL or AUTOMATIC reset of high voltage after overload disable.

Entry Display shows parameter value being set.

Entry Display shows parameter and analog programming status display.

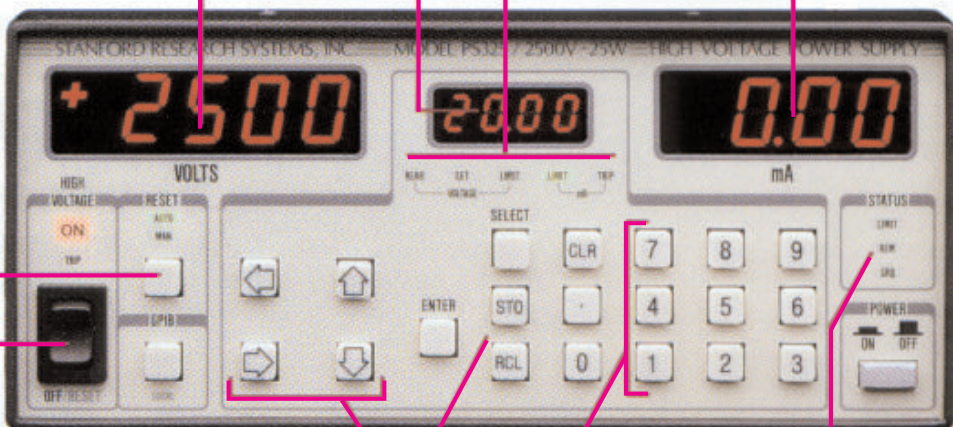

Front panel safety switch enables/disables the high voltage output and locks out GPIB control.

Store and recall up to 9 instrument setups.

Limit, remote control (GPIB) and SRQ status displays.

Numeric or cursor entry

Analog programming switch allows programming of output voltage by an analog input voltage. (Status is displayed on front panel.)

Polarity switch selects high voltage output polarity.

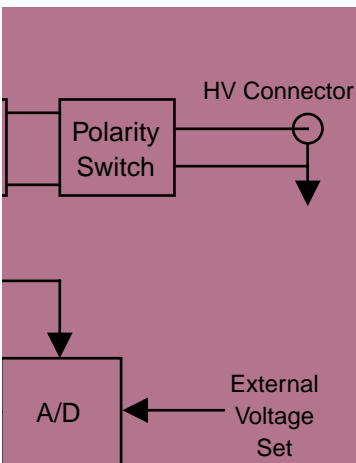

All PS300 Series power supplies operate the same way, differing only in maximum voltage, maximum current and output ripple.

A high voltage section (HV) converts low drive voltage into high voltage. (All high voltage section components in the HV section and shielded.) The output voltage (V) and current (I) are sensed and feedback to high gain compensation circuitry where they are compared to the programmed values. The compensation circuit controls the output voltage by setting the level of the drive voltage. A diode crossover allows control of both voltage and current.

Programmed values for the output, limits, and trips are set by the microprocessor through a D/A converter. Fast acting limit circuits check the sensed voltage and current. These work independently of the microprocessor so they can react quickly to protect both the supply and load.

And A/D converter reads the sensed values so they can be displayed on the front panel or read over the GPIB interface. The A/D also reads the External Voltage Set (when enabled) so all limits are functional in the analog programming mode.

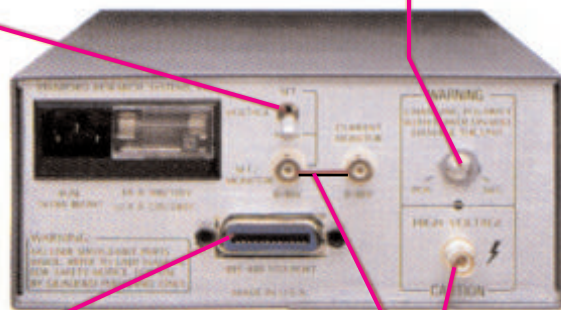

Optional GPIB interface provides full remote instrument programmability and control.

Analog voltage and current monitor outputs provide 0 to 10 volts for 0 to full-scale outputs.

SHV high voltage output connector

Specifications

Output

Voltage Set Accuracy	0.01% + 0.05% of full scale
Voltage Display Accuracy	V Set Accuracy \pm 1 Volt (typ)
Voltage Resolution	1 Volt (set & display)
Voltage Resettability	1 Volt
Voltage Limit Range	0 to 100% of full scale
Voltage Regulation	0.001% for \pm 10% line voltage change; 0.005% for 100% load change.
Output Ripple	<0.0015% of full scale (Vrms typ)
Current Limit and Trip Range	0 to 105% of full scale
Current Set Accuracy	0.01% + 0.05% of full scale
Current Resolution	PS350: 1 μ A; PS325, PS310: 10 μ A
Current Display Accuracy	I Set Accuracy \pm 1 μ A (PS350) or 10 μ A (PS325 or PS310) (typ)
Stability	0.01% per hour, <0.03% per 8 hours
Temperature Drift	50 ppm/ $^{\circ}$ C, 0 to 50 $^{\circ}$ C (typ)
Protection	Arc and short circuit protected; programmable voltage and current limits and current trip.
Recovery Time	12ms for 40% step change in load current (typ)
Discharge Time	<6 sec (to < 1% of full scale voltage with no load typ)

Analog Programming

Remote Voltage Set	Remote Voltage setting is only enabled when the rear panel switch is in the REMOTE position. This disables both the front panel and GPIB voltage setting functions.
Range	0 to +10 Volts sets 0 to full scale output.
Accuracy	0.2% of full scale.
Update Rate	16Hz
Output Slew Rate	<0.30 sec for 0 to full scale under full load.
Voltage and Current Monitor	0 to + 10 Volts monitors 0 to full scale output.
Accuracy	0.2% of full scale.
Update Rate	8Hz
IEEE-488 GPIB Operation	(Option 01)
Programmable Functions	Output Voltage, Output Voltage Limit, Current Limit, Current Trip, Reset Mode, Output Enable, Reset, SRQ Response Mode.
Readback Functions	Output Voltage, Output Current, Limit Settings. Status. Programming Error Codes, Error Condition. Service Request.

General

Display	4 digits (plus sign) voltage display, 4 digit current display, 4 entry display, Error Condition, Service Request.
Output Connector	SHV high voltage
Dimensions	16.0" x 8.3" x 3.5"
Weight	8 lbs.
Power	100, 120, 220, 240 Vac, 50 Watts

Ordering Information

PS310	\pm 1.25 KV HV Power Supply
PS325	\pm 2.5 KV HV Power Supply
PS350	\pm 5.0 KV HV Power Supply
Option 01	GPIB Interface
Option 02S	Single Rack Mount
Option 02D	Dual Rack Mount
Option 03A	SHV to SHV cable, 10'
Option 03B	SHV to MHV cable, 10'



STANFORD RESEARCH SYSTEMS

1290 D Reamwood Avenue • Sunnyvale, CA 94089

Telephone (408)744-9040 • FAX: (408)744-9049

Email: info@thinkSRS.com • www.thinkSRS.com

Printed in USA ©1995 Stanford Research Systems, Inc All specifications and prices subject to change

All trademarks are the property of their respective owners