



**Advanced Test Equipment Rentals**  
**www.atecorp.com 800-404-ATEC (2832)**

## **Service Guide**

**Agilent Technologies**

### **NFA Series Noise Figure Analyzers**

**This manual provides documentation for the following instruments:**

**Agilent Technologies NFA Series**

**N8972A (10 MHz - 1.5 GHz)**

**N8973A (10 MHz - 3.0 GHz)**

**N8974A (10 MHz - 6.7 GHz)**

**N8975A (10 MHz - 26.5 GHz)**



**Agilent Technologies**

**Manufacturing Part Number: N8972-90004**

**Printed in UK**

**December 2001**

© Copyright 2000, 2001 Agilent Technologies, Inc.

The information contained in this document is subject to change without notice.

Agilent Technologies makes no warranty of any kind with regard to this material, including but not limited to, the implied warranties of merchantability and fitness for a particular purpose. Agilent Technologies shall not be liable for errors contained herein or for incidental or consequential damages in connection with the furnishing, performance, or use of this material.

---

## Safety Notes

This instrument has been designed and tested in accordance with publication EN61010-1(1993) / IEC 61010-1(1990) +A1(1992) +A2(1995) / CSA C22.2 No. 1010.1(1993) Safety Requirements for Electrical Equipment for Measurement, Control and Laboratory Use, and has been supplied in a safe condition. The instruction documentation contains information and warnings which must be followed by the user to ensure safe operation and to maintain the instrument in a safe condition.

The following examples illustrate warning and caution statements that are used throughout this manual.

---

### WARNING

**These servicing instructions are for use by qualified personnel only. To avoid electrical shock, do not perform any servicing unless you are qualified to do so.**

---

---

### WARNING

**Warning denotes a hazard. It calls attention to a procedure which, if not correctly performed or adhered to, could result in injury or loss of life. Do not proceed beyond a warning note until the indicated conditions are fully understood and met.**

---

---

### CAUTION

Caution denotes a hazard. It calls attention to a procedure that, if not correctly performed or adhered to, could result in damage to or destruction of the instrument. Do not proceed beyond a caution sign until the indicated conditions are fully understood and met.

---

The following safety notes are used throughout this manual. Familiarize yourself with each of the notes and its meaning before operating this instrument.

---

### WARNING

**This is a Safety Class 1 Product (provided with a protective earthing ground incorporated in the power cord). The mains plug shall only be inserted in a socket outlet provided with a protected earth contact. Any interruption of the protective conductor inside or outside of the product is likely to make the product dangerous. Intentional interruption is prohibited.**

---

<b>WARNING</b>	<b>The opening of covers or removal of parts is likely to expose dangerous voltages. Disconnect the product from all voltage sources while it is being opened.</b>
<b>WARNING</b>	<b>The noise figure analyzer contains potentially hazardous voltages. Refer to the safety symbols on the noise figure analyzer and the general safety notes in this service guide before operating the unit with the cover removed. Failure to heed the safety precautions can result in severe or fatal injury.</b>
<b>WARNING</b>	<b>If this product is not used as specified, the protection provided by the equipment could be impaired. This product must be used in a normal condition (in which all means for protection are intact) only.</b>
<b>WARNING</b>	<b>The power cord is connected to internal capacitors that may remain live for five seconds after disconnecting the plug from the power supply.</b>
<b>CAUTION</b>	This instrument is designed for use in Installation Category II and Pollution Degree 2 per IEC61010 and 60664 respectively.

---

## Warranty

This Agilent Technologies instrument product is warranted against defects in material and workmanship for a period of three year from date of shipment. During the warranty period, Agilent Technologies will, at its option, either repair or replace products which prove to be defective.

For warranty service or repair, this product must be returned to a service facility designated by Agilent Technologies. Buyer shall prepay shipping charges to Agilent Technologies and Agilent Technologies shall pay shipping charges to return the product to Buyer. However, Buyer shall pay all shipping charges, duties, and taxes for products returned to Agilent Technologies from another country.

Agilent Technologies warrants that its software and firmware designated by Agilent Technologies for use with an instrument will execute its programming instructions when properly installed on that instrument. Agilent Technologies does not warrant that the operation of the instrument, or software, or firmware will be uninterrupted or error-free.

---

## **LIMITATION OF WARRANTY**

The foregoing warranty shall not apply to defects resulting from improper or inadequate maintenance by Buyer, Buyer-supplied software or interfacing, unauthorized modification or misuse, operation outside of the environmental specifications for the product, or improper site preparation or maintenance.

NO OTHER WARRANTY IS EXPRESSED OR IMPLIED. AGILENT TECHNOLOGIES SPECIFICALLY DISCLAIMS THE IMPLIED WARRANTIES OF MERCHANTABILITY AND FITNESS FOR A PARTICULAR PURPOSE.

---

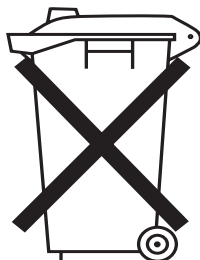
## **EXCLUSIVE REMEDIES**

THE REMEDIES PROVIDED HEREIN ARE BUYER'S SOLE AND EXCLUSIVE REMEDIES. AGILENT TECHNOLOGIES SHALL NOT BE LIABLE FOR ANY DIRECT, INDIRECT, SPECIAL, INCIDENTAL, OR CONSEQUENTIAL DAMAGES, WHETHER BASED ON CONTRACT, TORT, OR ANY OTHER LEGAL THEORY.

---

## **Lithium Battery Disposal**

When the battery on the A4 processor assembly (3 volt lithium battery, part number 1420-0338) is exhausted and/or ready for disposal, dispose of it according to your country's requirements. You can return the battery to your nearest Agilent Technologies Sales and Service office for disposal, if required. Refer to "Contacting Agilent Technologies, Inc." in Chapter 5 in for a list of Agilent Technologies Sales and Service offices.



**DO NOT THROW BATTERIES AWAY BUT  
COLLECT AS SMALL CHEMICAL WASTE.**

sk780a

---

# Contents

## 1. Troubleshooting the Noise Figure Analyzer (NFA)

What You Will Find in This Chapter .....	2
Before You Start .....	3
Replacement Assemblies .....	4
After an NFA Repair .....	5
ESD Information .....	5
Protection from Electrostatic Discharge .....	5
Handling of Electronic Components and ESD .....	7
Test Equipment Usage and ESD .....	7
For Additional Information about ESD .....	7
Service Equipment You Will Need .....	8
Check the Basics .....	9
Firmware Upgrades .....	10
Firmware Installation Procedure .....	10
Problems at Instrument Power-Up .....	11
Potentially Serious Faults .....	11
Clicking Noises .....	11
The NFA Always Powered On .....	11
Troubleshooting an Inoperative NFA .....	12
Check the NFA Setup .....	12
Initial Checks .....	12
If the Line Fuse Has Blown .....	13
If the Fan is Not Running .....	13
Checking the Power Supplies .....	14
If All Low Voltage Supplies Are Faulty .....	16
If Some Low Voltage Supplies Are Faulty .....	16
Checking the Power Supplies Without a Test Board .....	17
Troubleshooting the LCD Display .....	18
Using the Internal Service-Diagnostic Routines .....	20

---

## Contents

Timebase (in Service Menu) . . . . .	20
Noise Source On or Off (in Service Menu) . . . . .	20
Align YTF . . . . .	21
IF Test (in Service Menu) . . . . .	21
Write to SNS (in Service Menu) . . . . .	21
Restore System Defaults . . . . .	21
Front Panel Test (in Diagnostic Menu) . . . . .	22
Troubleshooting the A4 Processor Assembly . . . . .	23
Initial Checks . . . . .	23
Bootrom Self-Test Check . . . . .	24
Clearing Dynamic RAM . . . . .	25
Troubleshooting the A6 Floppy Drive Assembly . . . . .	26
Troubleshooting the A7A1 GPIB Assembly . . . . .	27
Printer Faults . . . . .	27
GPIB Faults and Errors . . . . .	28
Communicating with the NFA using N2716A Software . . . . .	28
Troubleshooting the A7A2 SIB Assembly . . . . .	29
RS 232 Faults and Errors . . . . .	29
LO GPIB Faults and Errors . . . . .	29
Troubleshooting the +28V Noise Source supply . . . . .	29
Smart Noise Source (SNS) Faults and Errors . . . . .	31
Troubleshooting the A7A4 DSP Assembly . . . . .	32
Troubleshooting the A7A5 IF Assembly . . . . .	34
The Clock Signal Check . . . . .	34
IF Gain Control Check . . . . .	35
Bandwidth Shape Check . . . . .	35
Noisy Assembly Check . . . . .	36
When replacing the IF Assembly . . . . .	37
Setting up and Using the VEE Program . . . . .	37

---

## Contents

Installing the VEE Runtime Environment . . . . .	37
Running the VEE program . . . . .	38
<b>2. Troubleshooting the Front End and RF Sections</b>	
What You Will Find in This Chapter . . . . .	40
Recommended Test Equipment . . . . .	40
Recommended Connector Torque Settings . . . . .	40
Checking the Measurement Path . . . . .	41
Troubleshooting the A2 Front End and Input Stage . . . . .	42
RF Front End and Input Stage Verification Procedure . . . . .	42
Test Point A . . . . .	43
Test Point B . . . . .	43
Test Point C . . . . .	44
Test Point D . . . . .	45
Troubleshooting the A3 Microwave Front End, A2 Front End, and Input Stage . . . . .	46
RF Front End and Input Stage “Quick Check” Verification Procedure in Low Band . . . . .	47
Test Point A . . . . .	47
Test Point B . . . . .	48
Test Point C . . . . .	48
Test Point D . . . . .	49
Quick Check RF Procedure for High Bands . . . . .	50
Test Point E . . . . .	50
Test Point F . . . . .	51
Verifying the A8 RF Section Performance . . . . .	52
Quick A8 Troubleshooting Procedure . . . . .	52
Another Quick Check using the 10.0 MHz Out Frequency Reference Accuracy Test . . . . .	53
Detailed A8 RF Troubleshooting Procedure . . . . .	54

---

# Contents

Verifying the A8 RF Section Performance .....	59
Quick Troubleshooting Procedure in Low Band .....	59
Additional Quick Troubleshooting Information .....	60
Detailed Troubleshooting Procedure in Low Band .....	61
Quick Troubleshooting Procedure in High Bands .....	68
Additional Quick Troubleshooting Information .....	69
Detailed RF Troubleshooting for High Bands .....	70
Verifying the RF Input Attenuator and the Second Converter Switch Logic .....	76
Verifying the RF Input Attenuator Driver Functionality .....	77
Verifying the second Converter Switch Logic .....	78
<b>3. Error Messages</b>	
What You Will Find in This Chapter .....	80
Error Messages .....	81
Informational Messages .....	82
Error Queues .....	84
Error Message Format .....	85
Error Message Types .....	86
0: No Error .....	87
-499 to -400: Query Errors .....	88
-199 to -100: Command Errors .....	89
-399 to -300 and 201 to 799: Device-Specific Errors .....	94
-299 to -200: Execution Errors .....	109
<b>4. Assembly Descriptions and Block Diagrams</b>	
What You Will Find in This Chapter .....	112
A8 RF Assembly .....	113
Input Connector .....	114
A8A1 RF Assembly .....	114



---

## Contents

A8A1A1 Reference/Third Converter . . . . .	115
A8A1A2 Front End/LO . . . . .	115
A8A2 Second Converter . . . . .	116
A8A4 LO Amplifier/IF Switch (LOIS) . . . . .	116
A8A5 Input Attenuator . . . . .	116
A8A6 YIG-Tuned Filter/Mixer (RYTHM) . . . . .	116
A8FL1 3.1 GHz Low-Pass Filter (LPF) . . . . .	116
A2 RF Front End . . . . .	117
A3 Microwave Front End . . . . .	117
A7A3 Frequency Extension . . . . .	117
A7A5 IF Assembly . . . . .	118
IF Gain Control . . . . .	118
4.0 MHz Bandwidth Measurements . . . . .	118
Narrow Bandwidth Measurements . . . . .	118
IF Detector Linearity . . . . .	118
A4 Processor Assembly . . . . .	119
NFA Battery Information . . . . .	119
Interconnections to Other Assemblies . . . . .	120
A4A1 Flash SIMM . . . . .	120
A4A2 DRAM SIMM . . . . .	120
A5 Power Supply Assembly . . . . .	121
Interconnections to Other Assemblies . . . . .	121
A7 Motherboard and Card Cage Assemblies . . . . .	122
A7A1 GPIB Assembly . . . . .	122
A7A2 SIB Assembly . . . . .	122
A7A4 DSP Assembly . . . . .	122
Miscellaneous . . . . .	123
A1 Display/Front Panel . . . . .	123
Display . . . . .	123
A1A1 Front Panel Interface Board . . . . .	123

---

## Contents

A1A4 Backlight Supply . . . . .	123
A6 Floppy Drive Assembly . . . . .	123
Block Diagrams . . . . .	124
<b>5. Parts List</b>	
What You Will Find in This Chapter . . . . .	132
How to Order Parts . . . . .	133
Direct Mail-Order System . . . . .	133
Direct Phone-Order System . . . . .	134
Regular and Hotline Orders . . . . .	134
Replaceable Parts . . . . .	135
Contacting Agilent Technologies, Inc. . . . .	140
Instrument Serial Numbers . . . . .	141
How to Return Your Analyzer for Service . . . . .	142
Service Tag . . . . .	142
Original Packaging . . . . .	142
Other Packaging . . . . .	144
<b>6. Replacing Assemblies</b>	
What You Will Find in This Chapter . . . . .	146
Before You Start . . . . .	147
Service tools you will need . . . . .	147
After a noise figure analyzer repair . . . . .	147
Removal and Replacement Procedures in This Chapter . . . . .	148
Instrument Outer Case . . . . .	149
Chassis Cover . . . . .	153

---

## Contents

A1 Front Frame Assembly .....	155
Extension of the Front Frame Assembly.....	155
Removal .....	156
Replacement .....	158
A1MP16 Nameplate .....	159
Removal and Replacement.....	159
Connector Label.....	160
Removal .....	160
Installation .....	162
Replacement .....	163
Front Frame Subassemblies .....	164
A1A2 Display .....	164
A1A1 Front Panel Interface Board .....	167
Front Panel RPG .....	169
Removal/Replacement.....	169
Keypad/Flex Circuit.....	170
A1A3MP9 Lens/Keypad Assembly .....	171
A1A2DS1/A1A2DS2 Display Backlight.....	172
A1MP11 Media Door/Bezel.....	173
MP7 Vibration Support Bar .....	174
A3 Microwave Front End Assembly .....	177
A2 RF Front End .....	179
A4 Processor Assembly .....	181
A4A1 and A4A2 Flash and DRAM SIMM .....	183
A4BT1 Battery.....	184
A5 Power Supply .....	185
A5B1 Fan .....	187

---

## Contents

A6 Floppy Disc Assembly . . . . .	189
A7 Motherboard Assembly . . . . .	191
Card Cage Assemblies . . . . .	194
GPIB, RS-232, Frequency Extension, DSP, IF . . . . .	194
A8 RF Assembly . . . . .	197
A8 Sub-assemblies . . . . .	203
A8A4 LO Amp/IF Switch Assembly . . . . .	203
A8A6 YIG-Tuned Filter/Mixer . . . . .	204
A8A5 Input Attenuator . . . . .	207
A8A2 Second Converter . . . . .	209
Input Connector . . . . .	213
<b>7. Post-Repair Procedures</b>	
What You Will Find in This Chapter . . . . .	216
Before You Start . . . . .	217
Post-Repair Procedure . . . . .	217
Performance Verification and Adjustment Procedures . . . . .	219
Performance Verification Procedures . . . . .	219
Adjustment Procedures . . . . .	219
Agilent N2716A Performance Verification Software . . . . .	220
Test Environment . . . . .	220
Performance Verification Tests . . . . .	220

---

---

# **1 Troubleshooting the Noise Figure Analyzer (NFA)**

## **What You Will Find in This Chapter**

This chapter provides information that is useful when starting to troubleshoot an NFA failure. It provides procedures for troubleshooting common failures and isolating problems in the NFA. Assembly descriptions are located in Chapter 4, “Assembly Descriptions and Block Diagrams.”

Chapter 2, “Troubleshooting the Front End and RF Sections,” describes how to troubleshoot a failure in the measurement path, where the noise energy is down converted to the Intermediate Frequency (IF).

---

## Before You Start

There are four things you should do before starting to troubleshoot a failure:

- Check that you are familiar with the safety symbols marked on the instrument and read the general safety considerations and the safety note definitions given in the front of this guide.
- The NFA contains static sensitive components. Read the section entitled “ESD Information” on page 5 in this chapter.
- Become familiar with the organization of the troubleshooting information in this chapter.
- Read the rest of this section.

---

**WARNING** These servicing instructions are for use by qualified personnel only. To avoid electrical shock, do not perform any servicing unless you are qualified to do so.

---

---

**WARNING** The opening of covers or removal of parts is likely to expose dangerous voltages. Disconnect the product from all voltage sources while it is being opened.

---

---

**WARNING** The detachable power cord is the instrument disconnecting device. It disconnects the mains circuits from the mains supply before other parts of the instrument. The front panel switch is only a standby switch and is not a LINE switch (disconnecting device).

---

---

**CAUTION** Always position the instrument for easy access to the disconnecting device (detachable power cord).

---

---

**WARNING** To prevent electrical shock, disconnect the Noise Figure Analyzer from mains before cleaning. Use a dry cloth or one slightly dampened with water to clean the external case parts. Do not attempt to clean internally.

---

---

**WARNING** For continued protection against fire hazard, replace the line fuse only with same type and ratings (type 5A/250V). The use of other fuses or materials is prohibited.

---

---

<b>WARNING</b>	<b>This is a Safety Class 1 Product (provided with a protective earthing ground incorporated in the power cord). The mains plug shall only be inserted in a socket outlet provided with a protective earth contact. Any interruption of the protective conductor inside or outside of the product is likely to make the product dangerous. Intentional interruption is prohibited.</b>
<b>CAUTION</b>	Always use the three-prong ac power cord supplied with this product. Failure to ensure adequate earth grounding by not using this cord may cause product damage.
<b>CAUTION</b>	Before switching on this instrument, make sure that: <ul style="list-style-type: none"><li>• The correct fuse is installed.</li><li>• The supply voltage is in the specified range. As the instrument has an autoranging line voltage input, the supply voltage range is 90 Vac to 130 Vac or 200 Vac to 260Vac.</li></ul>

---

## Replacement Assemblies

The NFA assemblies are not repairable to component level. Therefore the following assemblies must be replaced as a full assembly.

- Display interface board (A1A1).
- Display (A1A2).
- Front end (A2).
- Microwave front end assembly (A3) used on N8974A and N8975A.
- Processor assembly (A4).
- Power supply assembly (A5).
- Floppy drive assembly (A6).
- Motherboard (A7).
- GPIB board (A7A1).
- RS-232 board (A7A2).
- Frequency extension assembly (A7A3) used on N8974A and N8975A.
- DSP assembly (A7A4) not used on N8972A.
- IF assembly (A7A5).
- RF assembly (A8).
- RF and microwave front end input microcircuits (A8Ax).



## After an NFA Repair

If one or more NFA assemblies have been repaired or replaced, perform the performance verification tests and any adjustments needed. Refer to Chapter 7, “Post-Repair Procedures,” for further information on the adjustments and performance verification tests.

The adjustments and performance verification tests can be done using the *Agilent N2716A Performance Verification and Adjustment Software*. The software can be purchased through your local Agilent Technologies sales and service office. (See “Contacting Agilent Technologies, Inc.” on page 140.)

---

**NOTE**

---

Option 0BW does not include performance verification software. Performance verification can be done manually using the procedures in the calibration guide.

## ESD Information

### Protection from Electrostatic Discharge

Electrostatic discharge (ESD) can damage or destroy electronic components. All work on electronic assemblies should be performed at a static-safe workstation. Figure 1-1 shows an example of a static-safe workstation using two types of ESD protection:

- Conductive table-mat and wrist-strap combination.
- Conductive floor-mat and heel-strap combination.

Both types, when used together, provide a significant level of ESD protection. Of the two, only the table-mat and wrist-strap combination provides adequate ESD protection when used alone. To ensure user safety, the static-safe accessories must provide at least 1 megohm of isolation from ground. Refer to Table 1-1 for information on ordering static-safe accessories.

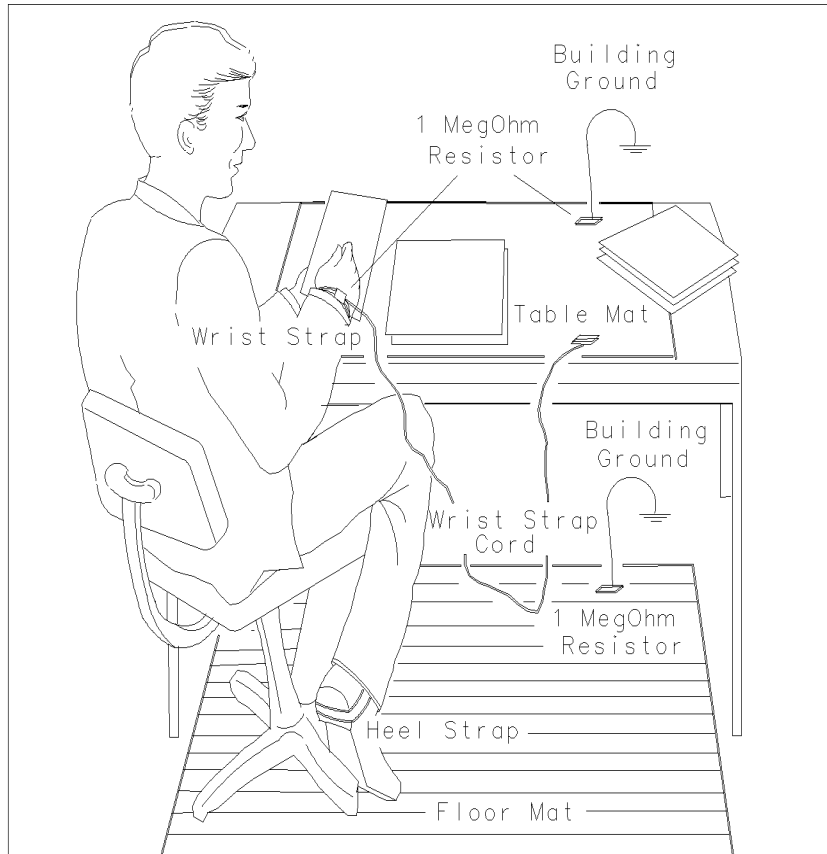
---

**WARNING**

---

**These techniques for a static-safe workstation should not be used when working on circuitry with a voltage potential greater than 500 volts.**

**Figure 1-1** Example of a Static-Safe Workstation



FORMAT46

**Table 1-1** Static Safe Accessories

Part Number	Description
85043-80013	Set includes: 3M static control mat 0.4 m × 0.6 m (16 inches × 23 inches) and 4.6 cm (15 ft) ground wire, wrist strap, and wrist-strap cord.
9300-0980	Wrist-strap cord 1.5 m (5 ft).
9300-1367	Wrist-strap, color black, stainless steel, without cord, has four adjustable links and a 7 mm post-type connection.
9300-1308	ESD heel-strap (reusable 6 to 12 months).

### **Handling of Electronic Components and ESD**

The possibility of unseen damage caused by ESD is present whenever components are transported, stored, or used. The risk of ESD damage can be greatly reduced by close attention to how all components are handled.

- Perform work on all components at a static-safe workstation.
- Keep static-generating materials at least one meter away from all components.
- Store or transport components in static-shielding containers.

---

**CAUTION**

---

Always handle printed circuit board assemblies by the edges. This will reduce the possibility of ESD damage to components and prevent contamination of exposed plating.

### **Test Equipment Usage and ESD**

- Before connecting any coaxial cable to an NFA connector, momentarily short the center and outer conductors of the cable together.
- Personnel should be grounded with a 1 megohm resistor-isolated wrist-strap before touching the center pin of any connector and before removing any assembly from the NFA.
- Be sure that all NFAs are properly earth-grounded to prevent build-up of static charge.

### **For Additional Information about ESD**

For more information about preventing ESD damage, contact the Electrical Over Stress/Electrostatic Discharge (EOS/ESD) Association, Inc. The ESD standards developed by this agency are sanctioned by the American National Standards Institute (ANSI).

## Service Equipment You Will Need

In addition to the troubleshooting aids listed in Table 1-2, refer to Table 2-1 and the *N2716A Getting Started Guide* or the *NFA Noise Figure Analyzers Calibration And Performance Verification Guide* for a list of the recommended equipment needed to troubleshoot and repair the NFA. Although Agilent Technologies equipment is recommended, any manually operated equipment that meets the critical specifications can be substituted for the recommended model.

**Table 1-2**

**Troubleshooting Aids**

<b>Part number</b>	<b>Description</b>
E4401-60235	Power supply service test board.
E4401-60240	Attenuator and second converter board assembly and cable consisting of the following: <ul style="list-style-type: none"><li>• E4401-60236</li><li>• E4401-60239</li></ul>
E4401-60237	40-Pin extender board.
E4401-60238	100-Pin extender board.

## Check the Basics

A problem can often be resolved by repeating the procedure you were following when the problem occurred. Before calling Agilent Technologies or returning the NFA for service, please make the following checks:

- Check the line fuse. See the section “If the Line Fuse Has Blown” on page 13.
- Is there power at the receptacle?
- Is the NFA turned on? Make sure the fan is running, which indicates that the power supply is on. See the section “If the Fan is Not Running” on page 13.
- If the display is dark or dim, press the upper **Viewing Angle** key in the upper-left corner of the front panel. If the display is too bright, adjust the lower **Viewing Angle** key in the upper-left corner of the front panel. See the section “Troubleshooting the LCD Display” on page 18.
- If other equipment, cables, and connectors are being used with your NFA, make sure they are connected correctly and operating correctly.
- Review the procedure for the measurement being performed when the problem appeared. Are all the settings correct?
- If the NFA is not functioning as expected, return the NFA to a known state by pressing the **Preset** key.

Some NFA settings are not affected by a Preset. Refer to the “Front Panel Key Reference” chapter of the User’s Guide for information on settings affected by a Preset.

- Is a measurement being performed? And are the expected results within the specifications and capabilities of the NFA? Refer to the appropriate “Technical Specifications” chapter in the *Agilent NFA Series Calibration and Performance and Verification Guide* for more details.
- In order to meet specifications, the NFA must be aligned. To verify that Alignment is selected, press the **System** key, **Alignment** menu key and enable **Alignment (On)**. Refer to the “Front Panel Key Reference” chapter in the User’s Guide for more details.
- Is the NFA displaying an error message? If so, refer to Chapter 3, “Error Messages.”
- If the necessary test equipment is available, perform the performance verification tests in the *Agilent NFA Series Calibration and Performance and Verification Guide*. Record all results on the appropriate model’s Test Record form. The form is contained in the *Agilent NFA Series Calibration and Performance and Verification Guide*.

**Check the Basics**

**Firmware Upgrades**

It may be necessary to upgrade the firmware. The standard procedure for upgrading the NFA's firmware is using the A6 Floppy disk drive. The disks can be ordered directly from Agilent or the data downloaded from the Agilent web site at <http://www.agilent.com/cm/wireless/nfa.html>.

If you use the web site to obtain the latest Firmware Revisions click on NFA Series Firmware Upgrade.

The firmware is supported using 6 disks. Disk 1 contains the loader information. Disks 2 to 6 contain the firmware.

**Firmware Installation Procedure**

- Step 1.** Ensure the NFA is powered off.
- Step 2.** Insert the Loader disk into the NFA's floppy drive.
- Step 3.** Power on the NFA. (This may take several seconds to boot)

---

**NOTE**

The Loader revision shown on the NFA screen may have a different version number from the firmware being loaded.

---

**CAUTION**

Do not to recycle the power until prompted. This prompt occurs when the installation is complete.

- Step 4.** Follow the on-screen instructions, inserting each disk when prompted.
- Step 5.** When re-booting the splash screen displays the new revision of firmware.

## **Problems at Instrument Power-Up**

This section describes symptoms that can occur when the NFA is first powered on.

### **Potentially Serious Faults**

---

**CAUTION**

Immediately unplug the NFA from the ac power line if the unit shows any of the following symptoms:

- Smoke, arcing, or unusual noise from inside the unit, except the “Clicking Noises” discussed below.
- No response of any kind when unit is plugged into ac power mains and turned on.
- The NFA ac power fuse blows.
- A circuit breaker or fuse on the main ac power line opens.

These potentially serious faults must be corrected before proceeding. Refer to “Troubleshooting an Inoperative NFA” on page 12.

---

### **Clicking Noises**

The microwave NFA models (N8974A and N8975A) occasionally emit “clicking” noises. This is caused by the NFA’s 3.0 GHz mechanical switch and is normal if the measurement frequency range crosses over that point.

### **The NFA Always Powered On**

If the NFA always turns on when power is applied, check the rear of the NFA. There is an “always on” power mode switch that can be changed. Refer to the Overview of the Rear Panel section of the User’s Guide for information on this switch.

## **Troubleshooting an Inoperative NFA**

When an NFA appears to be faulty, for example, no display or inoperative fan, there is often little evidence that points directly to the cause. This section provides steps and solutions to typical failure modes.

### **Check the NFA Setup**

Perform the steps in the section titled “Check the Basics” on page 9.

#### **Initial Checks**

Perform the following initial checks when first troubleshooting an inoperative NFA.

**Step 1.** Check the fan is running.

1. If the fan is not running, refer to the section “If the Fan is Not Running” on page 13.
2. If the fan is running, proceed to Step 2 if no other cause can be found.

**Step 2.** Check the power supplies.

1. To check the power supply voltages, refer to the section “Checking the Power Supplies” on page 14.
2. If the power supply voltages all measure correctly, suspect a defective processor, a defective LCD, or interface board.

**Step 3.** Check the display is on.

1. If the display is blank, refer to the section “Troubleshooting the LCD Display” on page 18. Also verify that there is not a firmware error by performing the “Bootrom Self-Test Check” on page 24.

**Step 4.** Checks the processor assembly can perform the following.

1. The LEDs along the top edge (shown in Figure 1-9) of the A4 Processor Assembly must all be off. To check their functionality, power cycle the NFA. The processor LEDs should all go on for a few seconds, then go off. If one or more LEDs remains on, suspect the A4 Processor Assembly is defective. Refer to the section “Troubleshooting the A4 Processor Assembly” on page 23.



## **If the Line Fuse Has Blown**

If the line fuse has blown, perhaps a nonstandard fuse with too low a current rating was installed. If the line fuse still blows, suspect that the power supply assembly is defective.

---

**WARNING**

---

**For continued protection against fire hazard, replace fuse only with same type and ratings, (5 A/250 V). The use of other fuses or materials is prohibited.**

## **If the Fan is Not Running**

---

**CAUTION**

---

The power supply may be hot if the instrument has been operating without the fan running. Allow the instrument to cool down before troubleshooting.

1. If there is no display:
  - a. Unplug the line-power cord.
  - b. Change the switch at the rear of the NFA so the power is always on. Refer to the Overview of the Rear Panel section of the User's Guide for information on this switch. This will bypass the front panel power switch.
  - c. If the fan still does not start, suspect a defective power supply assembly. Refer to the section "Checking the Power Supplies" on page 14, to check individual supply voltages.
  - d. If the fan starts, this indicates a problem with the front panel switch or the circuitry to the front panel switch.
2. If there is a display:
  - a. Remove the NFA outer case. Refer to Chapter 6 for removal details.
  - b. Measure the fan voltage.
  - c. The fan voltage can be checked directly at the center of the fan where the wires connect. The fan normally operates on a voltage ranging from  $-5$  to  $-16$  Vdc depending on the fan speed needed, based on the temperature of the NFA. As NFA temperature increases, fan voltage should become more negative, increasing the speed of the fan.

If the correct voltage is present, suspect a defective fan.

If the voltage is not present, check the plug where the fan wires attach to the power supply board. If this looks good, suspect a defective power supply. Refer to Chapter 6 for information on how to remove the power supply.

## **Checking the Power Supplies**

To verify the power supply voltages using a power supply test board do the following:

- Step 1.** Remove the NFA's outer case and inner shield. See Chapter 6.
- Step 2.** Plug the test board (E4401-60235) into any available slot, except the slot for the processor board.
- Step 3.** Observe the LEDs on the test board. See Figure 1-2.

Depending on the options installed in your NFA, you may need to remove one or more option cards to allow access to the test points. Refer to Chapter 6 for removal instructions.

The power supply test board LEDs will be On if the voltages are within 10% of their specified voltages. Use a digital voltmeter to verify that the supplies are within specifications. The voltages measured should be within the values listed in Table 1-3.

---

**NOTE**

For accurate analog and digital measurements, use the analog common (ACOM) and digital common (DCOM) test points respectively as listed in Table 1-3. These points are clearly marked on the test board. See Figure 1-2.

---

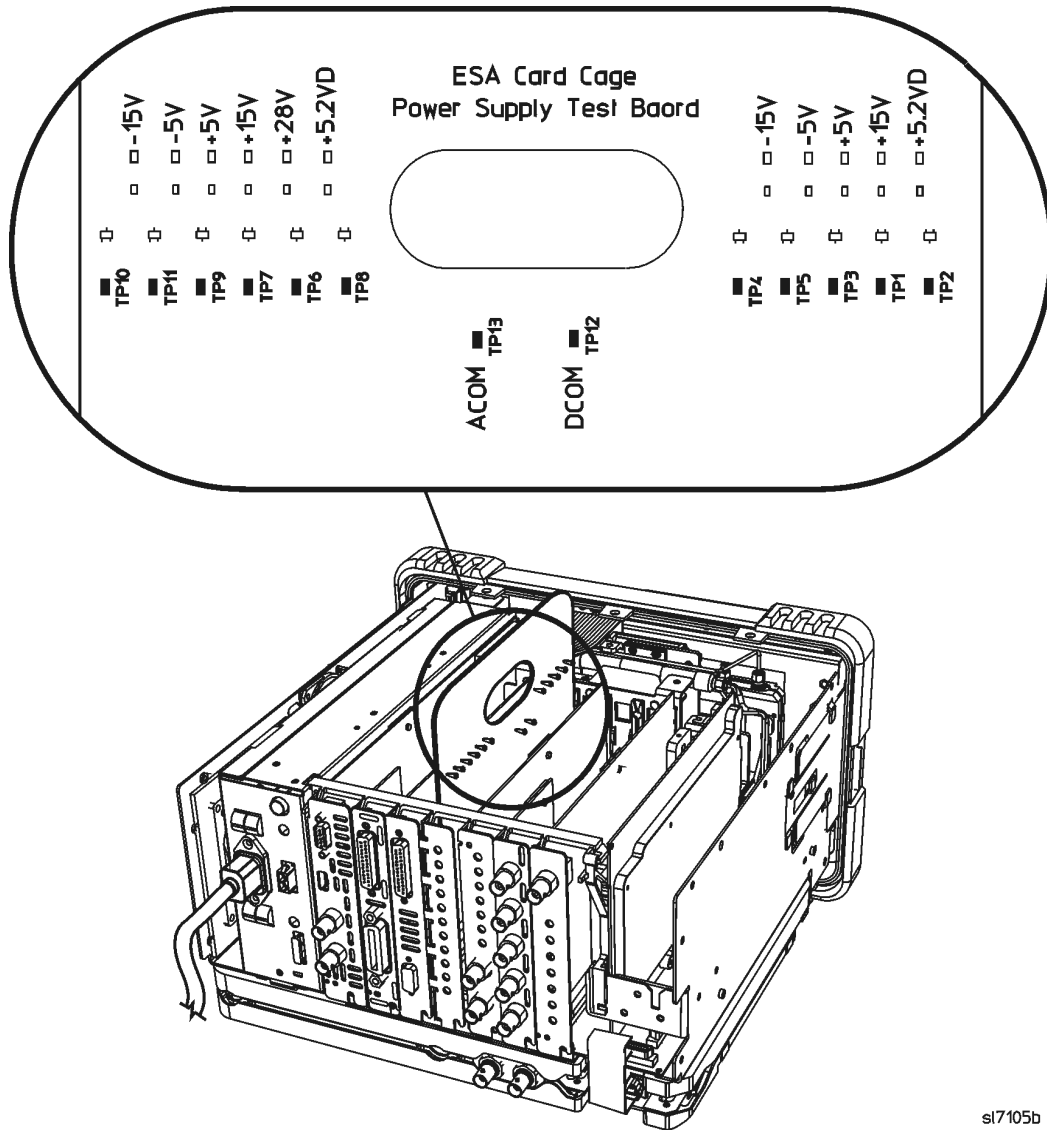
**WARNING**

**The NFA contains potentially hazardous voltages. Refer to the safety symbols provided on the NFA, and in the general safety instructions in this guide, before operating the unit with the cover removed. Ensure that safety instructions are strictly followed. Failure to do so can result in severe or fatal injury.**

---

**Figure 1-2**

**Power Supply Test Board Voltage Locations**



sl7105b

**Table 1-3**

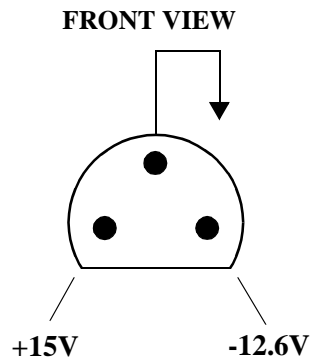
**Power Supply Tolerances**

Test Point	Common	Power Supply	Specification
TP4 or TP10	TP13, ACOM	-15 V	-15.22 to -14.78 Vdc
TP5 or TP11	TP13, ACOM	-5 V	-5.07 to -4.93 Vdc
TP3 or TP9	TP13, ACOM	+5 V	+4.93 to +5.07 Vdc
TP2 or TP8	TP12, DCOM	+5.2 VD	+5.1 to +5.3 Vdc
TP1 or TP7	TP13, ACOM	+15 V	+14.78 to +15.22 Vdc
TP6	TP13, ACOM	+28 V	+26.04 to +29.96 Vdc

Troubleshooting the Noise Figure Analyzer (NFA)  
**Troubleshooting an Inoperative NFA**

The +15 V and –12.6 V supplies can be measured directly on the probe power connector located on the front of the instrument. See Figure 1-3 for these test points. If –12.6 V is within limits, it is a reasonably good indicator that –15 V is within specifications.

**Figure 1-3**      **Probe Power Connector Voltages**



**If All Low Voltage Supplies Are Faulty**

If all the power supplies are faulty, suspect a defective A5 power supply assembly. Refer to Chapter 6 for removal instructions.

**If Some Low Voltage Supplies Are Faulty**

If some supplies are functioning while others are faulty, it is possible that one of the assemblies in the NFA is loading the power supply low.

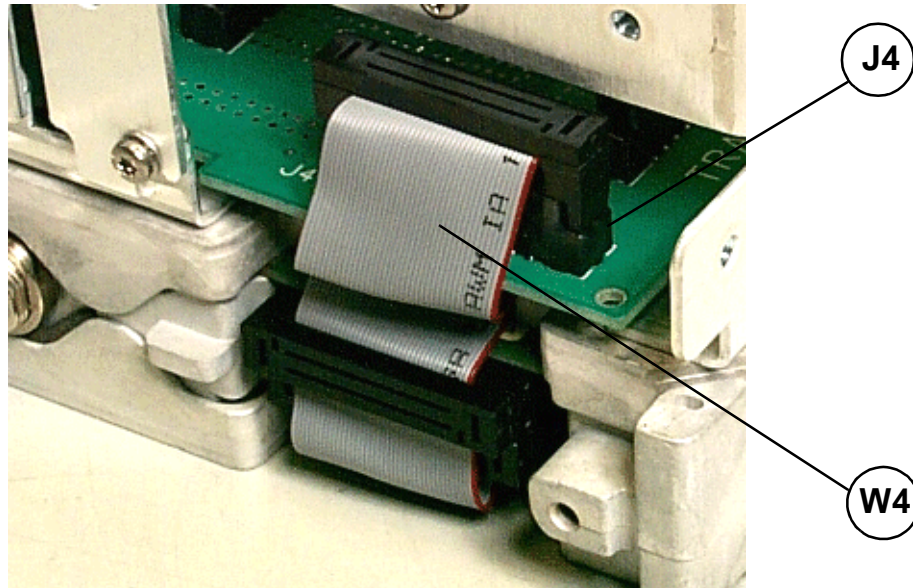
In this case it is necessary to sequentially remove the assemblies, taking care to disconnect the line-power cord before removing any assembly. A logical first step would be to unplug the RF assembly ribbon cable from the motherboard at the rear of the instrument, see Figure 1-4. This disconnects the complete RF section without having to remove it from the chassis. Refer to Chapter 6 for any other assembly removal procedures.

After an assembly is disconnected or removed, plug the line-power cord back into the NFA and remeasure the supply that was down. If it is still low, continue with the assembly removal. If the supply is now up, suspect the last assembly removed as being defective.

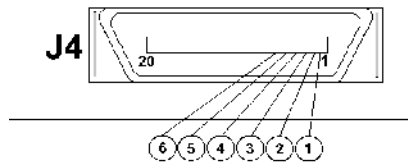
### Checking the Power Supplies Without a Test Board

If you do not have a power supply test board available, monitor the voltages at A7J4 after you have removed the W4 ribbon cable. See Figure 1-4 and Figure 1-5. The voltages measured should be within the values listed in Table 1-4.

**Figure 1-4** Location of J4 Connector on Motherboard



**Figure 1-5** Location of Test Points on J4 Connector



**Table 1-4** Power Supply Voltage Levels at Test Points

Test Point	J4 Location	Power Supply (Vdc)
1	Pin 1	+28
2	Pin 2	+15
3	Pin 3	+5
4	Pin 4	+5 (Const.)
5	Pin 5	-5
6	Pin 6	-15

## Troubleshooting the LCD Display

The only adjustment that can be made to the LCD display is the viewing angle. This is found on the front panel of the NFA in the upper left corner. The following procedure is a guide to troubleshoot the display.

- Step 1.** Ensure the NFA has gone through a full power-on sequence.
- Step 2.** Increase the display intensity by adjusting the viewing angle.
- Step 3.** If the display is not visible, connect an external VGA monitor to the rear panel VGA output connector on the NFA. If the video information is not present on the external VGA monitor, the most probable cause is the A4 processor assembly.

---

**NOTE** It is possible that some multi-sync monitors may not be able to lock to the 60 Hz sync pulse from the NFA.

---

- Step 4.** If the external VGA monitor is functioning, verify that the ribbon cables going to and from the A1A1 front panel interface assembly are aligned properly and securely plugged into the connectors.
- Step 5.** To determine whether the A1A2 LCD display or the A1A1 front panel interface assembly is defective, remove the front frame assembly. See Chapter 6, “Replacing Assemblies.”
- Step 6.** Troubleshoot the display by checking the inverter boards. The inverter board is shown in Figure 1-6.

Refer to Table 1-5 and carefully measure the voltage coming into the inverter board at CN1 pins 1-6 with a digital voltmeter.

---

**WARNING** **The inverter board contains high voltage for the backlights. Carefully remove the inverter board by taking out the two screws securing it to the front frame, then turn it over to access the CN1 connector.**

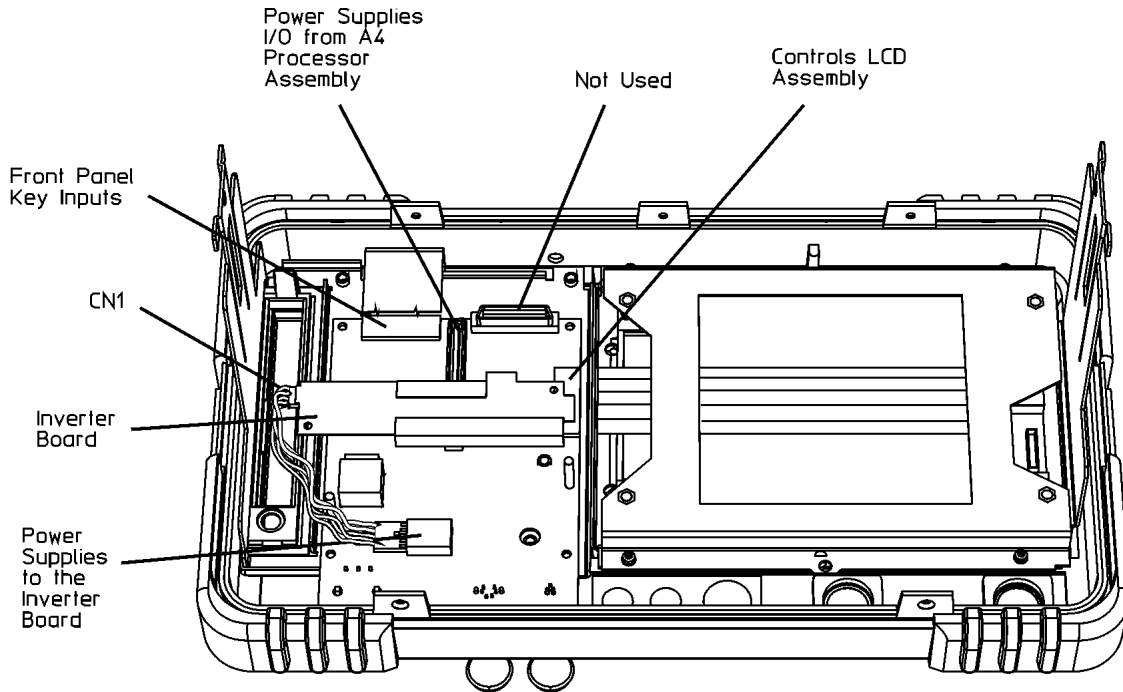
---

**Table 1-5** Measurement Locations and Expected Voltages

Measurement Location	Expected Voltage from A1A1 Front Panel Interface
CN1 Pin 1	0 Vdc
CN1 Pin 2	0 Vdc
CN1 Pin 3	5 Vdc
CN1 Pin 4	5 Vdc
CN1 Pin 5	30 mV
CN1 Pin 6	2.5 Vdc

The display is not field-repairable, and must be replaced as an assembly. Refer to Chapter 6 for part-number information.

**Figure 1-6** LCD Troubleshooting Measurement Locations



sl725b

If the voltages are correct, the most probable cause of failure is the A1A2 LCD assembly.

**NOTE**

The display has two backlights to illuminate the LCD. If both backlights are faulty, the screen will be dark. The backlights can be replaced individually. However, it is unlikely that both backlights are faulty simultaneously. If one backlight is faulty, the LCD illuminates but the darkness is noticeable, and you need to replace A1A2DS1 or A1A2DS2. It is recommended that both backlights be replaced at the same time.

## Using the Internal Service-Diagnostic Routines

The NFA has several routines which are helpful in diagnostics:

- Timebase (in Service Menu, password-protected).
- Noise Source On or Off (in Service Menu, password-protected).
- Align YTF (N8974A and N8975A models).
- IF Test (in Service Menu, password-protected).
- Write to SNS (in Service Menu, password-protected).
- Restore System Defaults.
- Front Panel Test (in Diagnostic menu).

---

### NOTE

The Service Menu is password protected. To access it, press the **System** key, **Service** menu key. At the password prompt, enter -2010 and press **Enter**.

---

### Timebase (in Service Menu)

This function allows adjustment of the coarse and fine digital to analog converters (DACs) controlling the voltage-controlled crystal oscillator (VCXO) timebase (OCXO, if Option 1D5 is installed). For more information on this refer to the *10 MHz Out Frequency Reference Adjustment* test in the *Calibration and Performance Verification Guide*.

The coarse DAC has a resolution of approximately 9 Hz per DAC count (for the VCXO). The fine DAC has a resolution of approximately 1.2 Hz per DAC count (for the VCXO). Any changes made to these DACs remain in effect until the NFA power is Preset. To save the timebase DAC values stored in EEROM press the **Save** menu key.

### Noise Source On or Off (in Service Menu)

This function allows you to switch the +28V noise source drive on or off and measure the voltage with a DVM.

- To switch the +28V drive on, press the **Noise Source On** menu key. Measure the voltage. The result should be within  $+28V \pm 0.1V$ .
- To switch the +28V drive off, press the **Noise Source Off** menu key. Measure the voltage. The result should be within  $0.0V \pm 1.0V$ .

For more information on this refer to the *Noise Source Supply Accuracy* test in the *Calibration and Performance Verification Guide*.



## Align YTF

---

**NOTE**

---

On models N8974A and N8975A where a problem occurs in the frequency range greater than 3.0 GHz attempt to align the YTF before any disassembly.

This function allows you to align the tuning current of the YIG Tuned Filter (YTF) against frequency. This is enabled by pressing **Align YTF**. To avoid an accidental key press you must press **Align YTF** menu key twice.

When the YTF alignment routine is finished you must press **Save YTF Alignment** to store the data to persistent memory. To avoid an accidental key press you must press **Save YTF Alignment** menu key twice.

## IF Test (in Service Menu)

This function is used by the factory and is not needed by any person repairing the NFA.

## Write to SNS (in Service Menu)

This function is used by the factory and is not needed by any person repairing the NFA.

## Restore System Defaults

**Restore Sys Defaults** resets the NFA to the original factory system default configuration. It also performs an instrument preset. To access this function, press the **System** key, the **Restore Sys Defaults** menu key. refer to the User's Guide for more information.

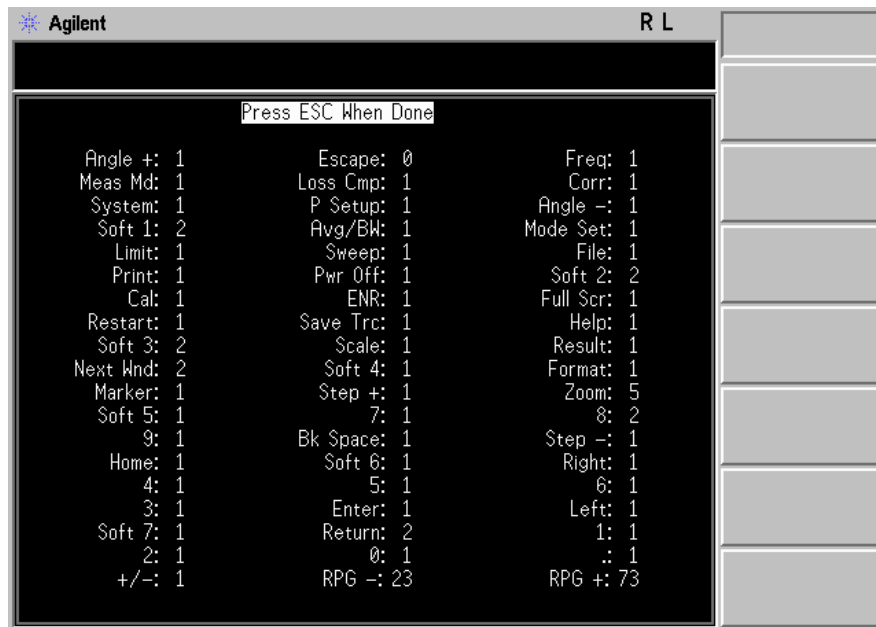
Use **Restore Sys Defaults** to return the NFA to a known "safe" state.

### Front Panel Test (in Diagnostic Menu)

This function allows you to verify the functionality of each front panel key (except **Preset**). The number next to each key name increments once each time the key is pressed. Rotating the RPG causes the number of pulses to be counted. Press **Esc** to exit. See Figure 1-7 as an example of a typical display.

Figure 1-7

Example of Front Panel Test Display



---

## Troubleshooting the A4 Processor Assembly

If you suspect you have a problem caused by the A4 processor assembly, use the following procedures to determine if A4 processor assembly must be replaced or if it can be restored to normal operation.

---

**NOTE** A4 processor assembly replacement can only be performed at an Agilent Service Centre.

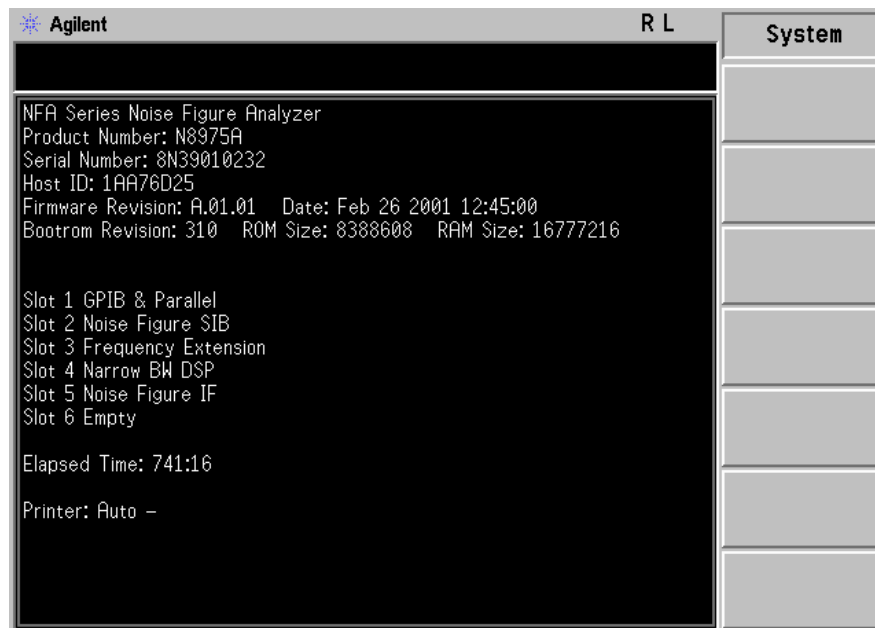
---

### Initial Checks

Some steps reference other troubleshooting procedures which appear later in this section.

- Step 1.** Verify the NFA product number, serial number, and firmware revision. Press **System, More 1 of 2, Show System**. The display should be similar to Figure 1-8.

**Figure 1-8** Example Show System Display



- Step 2.** Turn the NFA power off and reseal A4.
1. Referring to Figure 6-21 on page 174, remove the vibration support.
  2. Referring to Figure 6-26 on page 181, remove the single screw (4) which secures the processor assembly (8) to the chassis.
  3. Carefully lift the A4 processor assembly until the assembly disengages from the two motherboard connectors.
  4. Carefully plug the processor assembly into the motherboard.

Troubleshooting the Noise Figure Analyzer (NFA)  
**Troubleshooting the A4 Processor Assembly**

5. Replace the single screw (4) to secure the A4 processor assembly to the chassis. Turn the NFA power on.
6. If normal operation is not restored, continue with step 3.

**Step 3.** Perform the test described in “Bootrom Self-Test Check” on page 24.

**Step 4.** If proper operation has not been restored by following the preceding steps, replace A4 processor assembly.

**Bootrom Self-Test Check**

When the NFA is powered-on, the bootrom performs several self-tests. Before each self-test, the LEDs along the top edge of the A4 processor assembly light in a pattern which shows the test to be performed. As tests succeed, the LED pattern changes. If a test fails, the LED pattern remains in a state which corresponds to the test that failed. If the display is not functioning, observing the LED pattern provides information on the status of the self tests performed. Table 1-6 lists the LED patterns and their associated tests:

1. Power up the NFA. Verify that LED DS1 is flashing, approximately, once every second. If DS1 is continuously on or off, replace the A4 processor assembly.

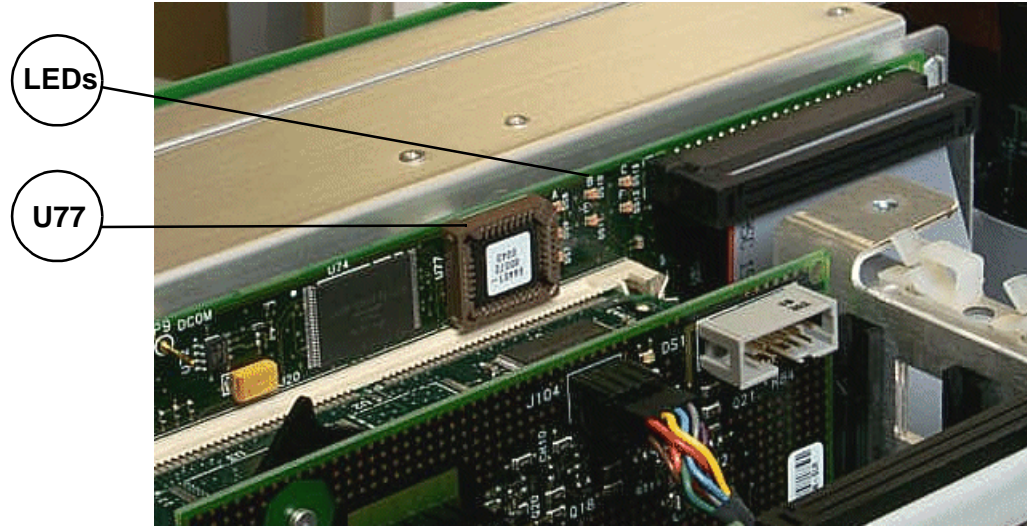
**Table 1-6**

**Self-Tests versus LED Pattern**

Self-Test Performed	LED Pattern							
	D S 1	D S 7	D S 13	D S 11	D S 9	D S 12	D S 10	D S 8
Start of Test	1	1	1	1	1	1	1	1
Bootrom Flash EPROM Checksum	1	1	1	1	1	1	1	0
RAM used by Bootrom (destructive)	1	1	1	1	1	1	0	0
Remainder of RAM (non-destructive)	1	1	1	1	1	0	0	0
Main Firmware Checksum	1	1	1	0	0	0	0	0
All Tests Completed Successfully	0	0	0	0	0	0	0	0

2. Power cycle the NFA and observe the LEDs shown in Figure 1-9. If all the LEDs do not light at the start of the test, the bootrom self-tests did not run. Turn the NFA power off and reseat the bootrom, A4U77, shown in Figure 1-9 (The A4U77 bootrom component is contained in a socket and should be inserted fully). After this is checked, power on the NFA. If the LEDs still do not light, replace the A4 processor assembly, as described in Figure 6-26 on page 181.

**Figure 1-9** Location of A4U77 Bootrom and LEDs



3. If the self-test indicates a RAM failure, perform the “Clearing Dynamic RAM” procedure below.

### **Clearing Dynamic RAM**

The RAM in the NFA can be cleared by setting switch 2 on A4S1 to the on position. The RAM can also be cleared by the following procedure:

1. Turn the NFA power Off.
2. Press and hold the **Esc** and **<-Prev** keys simultaneously.
3. Turn the NFA power On and wait 5 seconds while continuing to hold the **Esc** and **<-Prev** keys.
4. Release the **Esc** and **<-Prev** keys.
5. Cycle the NFA power. The entire RAM has been set to 0.

## **Troubleshooting the A6 Floppy Drive Assembly**

The A6 Floppy (A:) drive allows you to copy data to and from the NFA's internal (C:) drive.

If it fails to read or write data, perform one of the following procedures.

**Step 1.** Insert a noise source ENR data disk into the A: drive

**Step 2.** Upload the data from the A: drive to the C: drive.

For an explanation of the various file operations see the *User's Guide*.

**or**

**Step 1.** Insert the firmware upgrade kit loader disk 1 into the floppy drive

See "Firmware Installation Procedure" on page 10. for guidance on this procedure.

**Step 2.** Power cycle the NFA.

If either of these operations fail, replace the A6 Floppy Drive Assembly and repeat the procedure.

If the fault remains after the A6 Floppy Drive Assembly has been replaced, suspect the A4 Processor assembly.

---

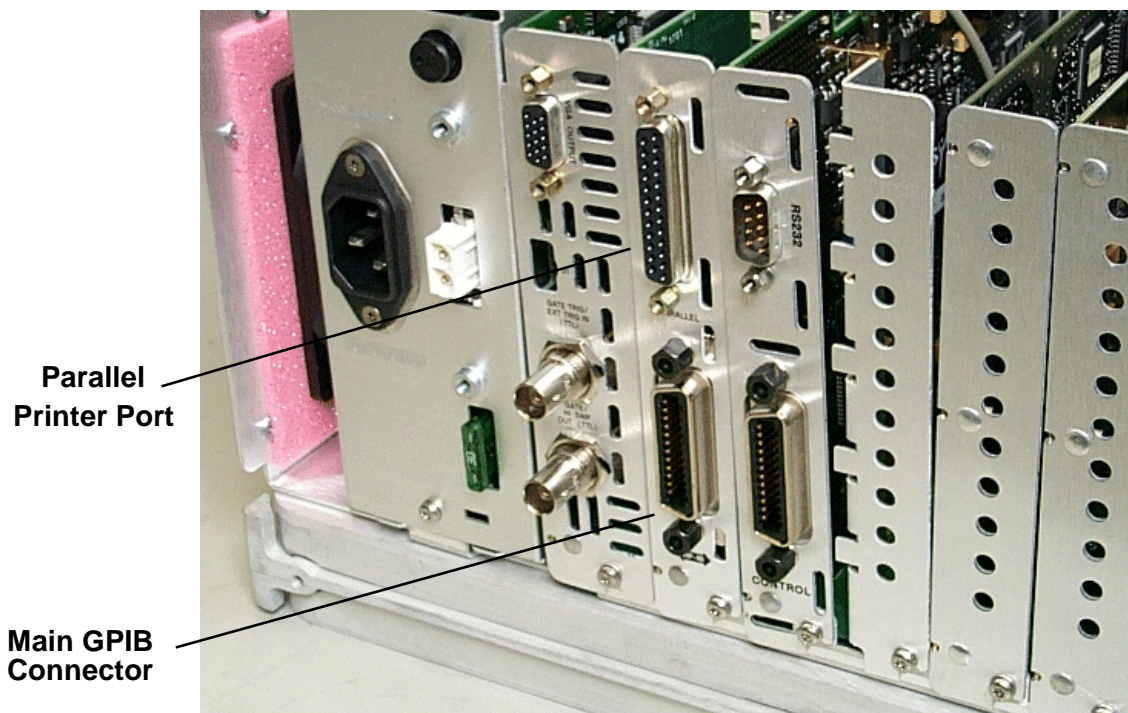
## Troubleshooting the A7A1 GPIB Assembly

This assembly allows you to control the NFA from a computer that has a General Purpose Interface Bus (GPIB). The GPIB assembly contains an IEEE-488 bus connector. It also includes a 25-pin parallel interface connector for connection with an IEEE 1284 cable to PCL3 or PCL5 compatible printers. The connectors are shown in Figure 1-10.

The parallel interface connector allows the NFA to print either its display or a system report.

**Figure 1-10**

**Location of GPIB and Printer Connectors**



### Printer Faults

If you have a printer fault and you have confirmed the connections and cabling to the printer are in good order. Suspect the A7A2 GPIB Assembly or the A4 Processor Assembly.

Perform the procedures in the section “Troubleshooting the A4 Processor Assembly” on page 23 to confirm the A4 Processor Assembly is functioning. If this is functioning, replace the suspected A7A2 GPIB Assemblies.

## GPIB Faults and Errors

If you have a communication error when working remotely and you have confirmed the connections and cabling have been checked. Suspect the A7A2 GPIB Assembly or the A4 Processor Assembly.

Perform the procedures in the section “Troubleshooting the A4 Processor Assembly” on page 23 to confirm the A4 Processor Assembly is functioning.

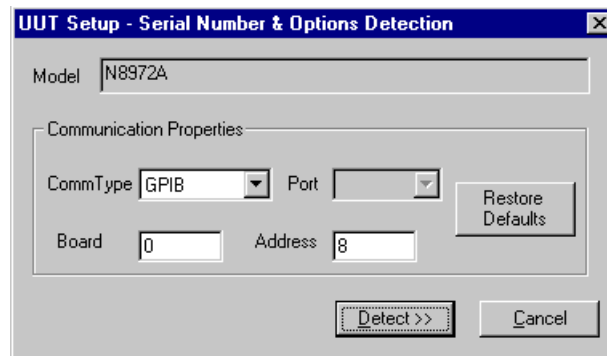
If this is functioning, and you have the N2716A Software, confirm the suspected A7A2 GPIB Assembly is at fault by performing the “Communicating with the NFA using N2716A Software” on page 28.

If you do not have the N2716A Software and the A4 Processor Assembly is functioning, replace the suspected A7A2 GPIB Assembly.

### Communicating with the NFA using N2716A Software

If you are using the *N2716A Performance Verification and Adjustment Software*, to attempt communication with the NFA. Ensure the correct model number is entered and the address is set to 8. Using the Auto Detect command in the Run window, press the Configure UUT key, followed by the Detect>> key, as shown Figure 1-11.

Figure 1-11



This command ensures the NFA’s listen and talk commands are functioning correctly and the A7A2 GPIB Assembly is working. The model number and serial number are displayed.

If the A7A2 GPIB Assembly is faulty then an error message appears, similar to the example shown in Figure 1-12. Replace the suspected A7A2 GPIB Assembly.

Figure 1-12

### N2716A Displaying a GPIB Communication Error





## **Troubleshooting the A7A2 SIB Assembly**

The A7A2 SIB Assembly controls the following four functions:

1. The RS-232 interface.

This allows you to control your NFA from a computer using that type of interface. It has an RS-232 9-pin connector (Agilent 5182-4794).

2. The LO GPIB interface.

This allows the dedicated control of an external LO by the NFA.

3. The +28V Noise Source Supply (pulsed).

This is supplied from this board to the BNC connector on the front panel. On older models, the cable supplying the +28V to the noise source is two sections, hence there is a connecting section in the card cage frame.

4. The SNS Connector interface.

This supplies the interface and associated hardware to control the SNS.

### **RS 232 Faults and Errors**

Suspect the A7A2 SIB Assembly or the A4 Processor Assembly.

Perform the procedures in the section “Troubleshooting the A4 Processor Assembly” on page 23 to confirm the A4 Processor Assembly is functioning. If this is functioning, replace the suspected A7A3 SIB Assembly.

### **LO GPIB Faults and Errors**

Suspect the A7A2 SIB Assembly or the A4 Processor Assembly.

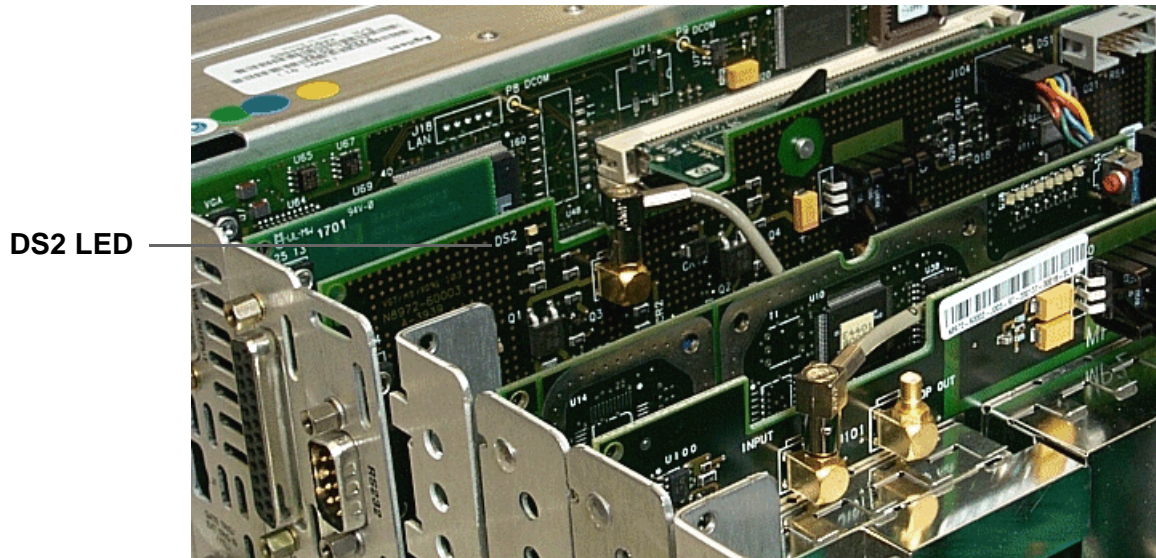
Perform the procedures in the section “Troubleshooting the A4 Processor Assembly” on page 23 to confirm the A4 Processor Assembly is functioning. If this is functioning, replace the suspected A7A3 SIB Assembly.

### **Troubleshooting the +28V Noise Source supply**

There are a number of checks that can be performed if there is a fault with the +28V supply.

- Visual Inspection of the LED A7A2DS2 on SIB Board, as shown in Figure 1-13. This LED should be flashing continuously, on or off. If this LED is not flashing replace the A7A2 SIB Assembly.

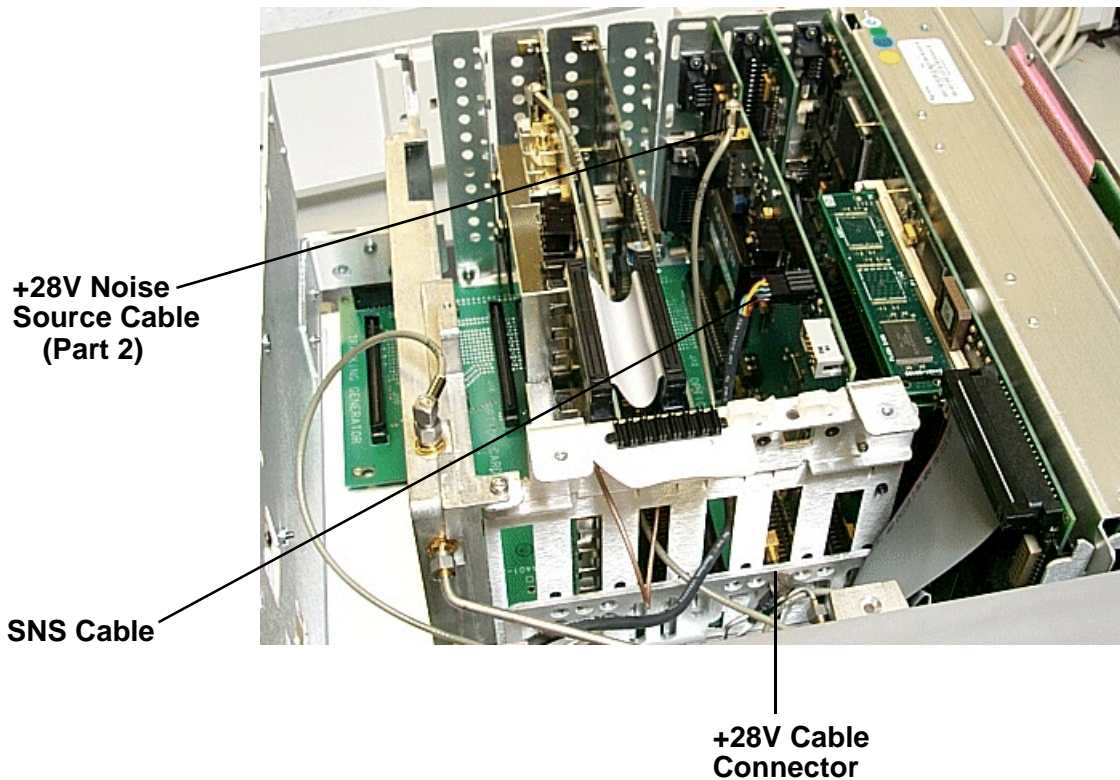
**Figure 1-13**      **Location of A7A2DS2 LED**



- Check the On and Off voltages. See the “Noise Source On or Off (in Service Menu)” on page 20 for an explanation of this procedure. Check the voltage at the A7A2J102 connector. If this does not work, suspect the A7A2 SIB Assembly or A5 PSU.

On older models, the cable from the A7A2J102 connector to the +28V drive is in two sections. Both sections need checked, as shown in Figure 1-14. If both results are approximately 0V, suspect the cables or BNC connector on the front panel.

Figure 1-14 Location of +28V and SNS Cables<sup>1</sup>



- If you have the *N2716A Performance Verification and Adjustment Software*, run the *+28V Noise Source Supply Accuracy Test*. If you do not have the software, run the *+28V Noise Source Supply Accuracy Test* in the *Calibration and Performance Verification Guide*. If this test fails and the visual inspection of the LED passed, check the calibration report values. If the results moderately out of specification, suspect the A7A2 SIB Assembly.

### Smart Noise Source (SNS) Faults and Errors

Suspect the A7A2 SIB Assembly or the A4 Processor Assembly.

Confirm the SNS cable and the SNS front panel connector are functioning.

---

#### NOTE

If you suspect the SNS or the interconnecting cable is faulty, refer to the *SNS Operating and Service Guide* for further information.

If you are satisfied the fault is not caused by the SNS cable and the SNS front panel connector. Perform the procedures in the section “Troubleshooting the A4 Processor Assembly” on page 23 to confirm the A4 Processor Assembly is functioning. If this is functioning, replace the suspected A7A2 SIB Assembly.

---

1. Figure 1-14 shows the older cabling arrangement of using two parts for the +28V supply. If one of these sections are faulty you can order the W28 cable and replace both sections.

---

## Troubleshooting the A7A4 DSP Assembly

This section applies to models, N8973A, N8974A, and N8975A only.

The Digital Sample Processing (DSP) Assembly is used when making the narrow bandwidth measurements of: 2.0 MHz, 1.0 MHz, 400.0 KHz, 200.0 KHz, and 100.0 KHz.

---

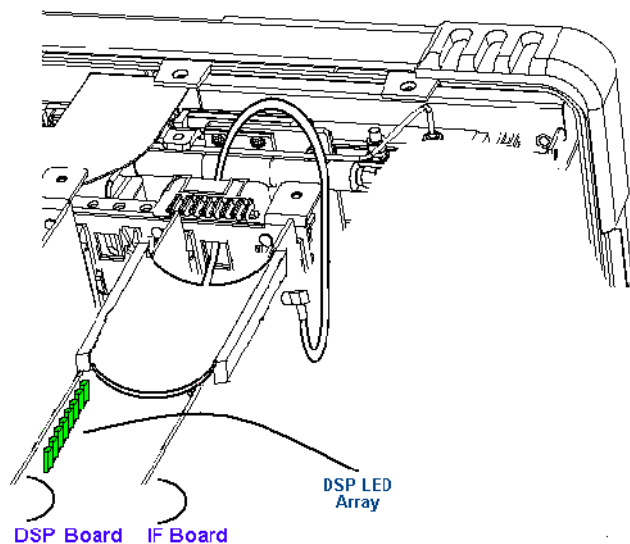
**NOTE**

The 4.0 MHz bandwidth is measured with the A7A5 IF Assembly.

The A4 DSP Assembly is connected to the IF Board by the control ribbon cable and the clock cable.

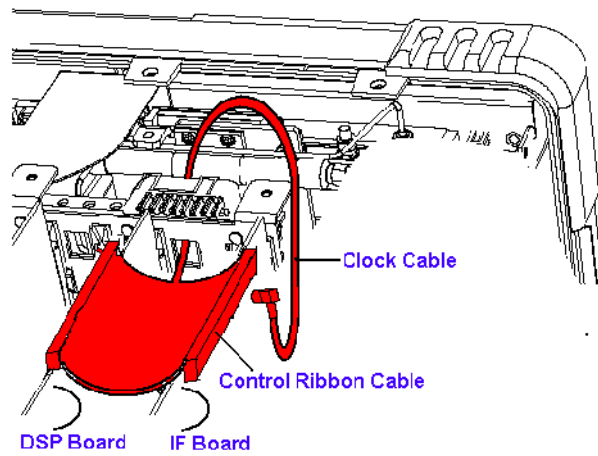
- Power on the NFA and ensure that the DSP LEDs, shown in Figure 1-15, initially flash ON then remain OFF. If this fails suspect the A4 DSP Assembly. Replace the suspect A4 DSP Assembly.

**Figure 1-15**



- If you have the *N2716A Performance Verification and Adjustment Software*, use the Frequency Accuracy Test to determine whether the narrow bandwidth measurements are functioning. If you do not have the software, run the Frequency Accuracy Test in the *Calibration and Performance Verification Guide*.
- If the Frequency Accuracy test fails at the narrow bandwidths and passes at 4.0 MHz, suspect the A4 DSP Assembly or its interconnecting cables shown in Figure 1-16.

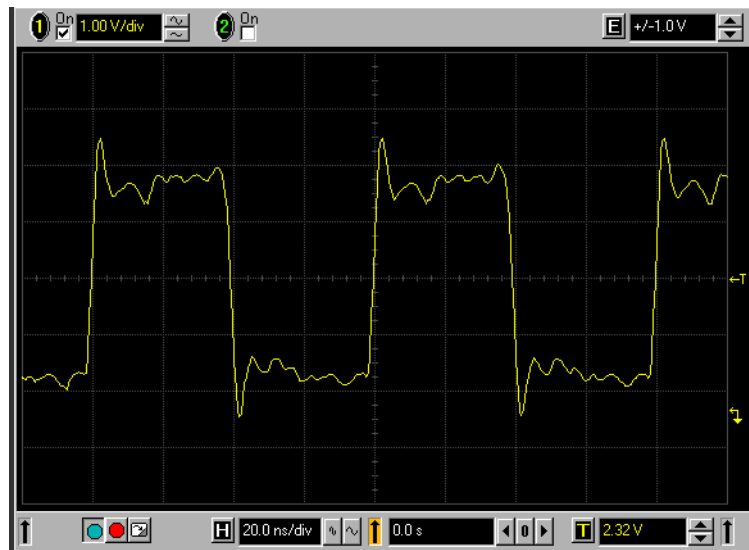
Figure 1-16



- Measure the clock signal on the cable input to A7A4P4. An example clock signal is shown in Figure 1-17. The frequency is 12.5 MHz.

**NOTE** The clock signal may have some ringing effects. This is normal.

Figure 1-17 Typical Clock Signal



## Troubleshooting the A7A5 IF Assembly

The A7A5 IF assembly is a selective 4.0 MHz wide Power Meter centered around a 21.4 MHz input signal. On the *Documentation and Software CD* there are VEE programs provided to help you troubleshoot the assembly.

You can check the following features on the IF Assembly:

- The Clock signal at A7A5J102.
- The IF Gain Control.
- The bandwidth shape.
- A noisy assembly.

### The Clock Signal Check

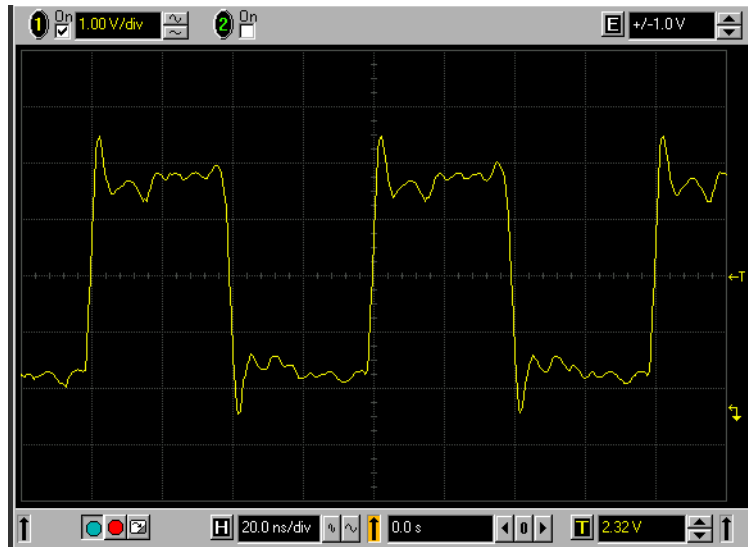
Measure the clock signal on the cable A7A5J102. An example clock signal is shown in Figure 1-18. If the clock signal is functioning, it suggests the PLD and the firmware are functioning.

---

**NOTE** The clock signal may have some ringing effects. This is normal.

---

**Figure 1-18** Typical Clock Signal



## **IF Gain Control Check**

Use the VEE program to check the attenuator steps.

- Step 1.** Remove the W31 cable from the A7A5J100 connector.
- Step 2.** Inject a 21.4 MHz signal from a Signal Generator into the J100 connector of the IF Assembly.
- Step 3.** Set the amplitude value of the signal generator to display 0 dB on the VEE power meter.
- Step 4.** Select a bank of attenuators and ensure the VEE power meter changes by the correct amount.

---

**NOTE**

---

The change displayed on the VEE power meter is only indicative and does not always display the exact value.

- Step 5.** Return the attenuator selection to 0 dB.
- Step 6.** Select the next bank of attenuators and repeat step 4 and step 5 until all five attenuator banks have been checked.

If this test fails replace the A7A5 IF Assembly.

## **Bandwidth Shape Check**

Use the VEE program to check the bandwidth selectivity of the IF Assembly by sweeping the IF input frequency.

- Step 1.** Remove the W31 cable from the A7A5J100 connector.
- Step 2.** Inject a 21.4 MHz signal from a Signal Generator into the J100 connector of the IF Assembly.
- Step 3.** Set the amplitude value of the signal generator to display 0 dB on the VEE power meter. As shown in Figure 1-19.



**Figure 1-19** Typical VEE display with IF Input Level Set to 0dB



**Step 4.** Set the Signal Generator to increment by 100 kHz.

**Step 5.** Sweep the Signal Generator's frequency and monitor where the -3 dB point is using the VEE power meter

Its level should be flat between 19.4 MHz and 23.4 MHz and start to cut off at  $21.4 \pm 2.0$  MHz.

If this test fails change the A7A5 IF Assembly.

### Noisy Assembly Check

Use the VEE program to check if the IF Assembly is noisy by monitoring its noise figure at maximum gain and minimum gain.

**Step 1.** Remove the W31 cable from the A7A5J100 connector.

**Step 2.** Set all the attenuator banks to 0 dB and ensure the VEE power meter value is about  $-21 \pm 3.0$  dB.

**Step 3.** Set all the attenuator banks to their maximum value and ensure the VEE power meter value is about  $-55 \pm 3.0$  dB.

If this check fails to vary in value by the correct amount change the A7A5 IF Assembly.



## **When replacing the IF Assembly**

The IF Board contains an EEPROM which holds unique detector linearity calibration data. Each IF board is characterized during the manufacturing process. The relevant calibration data is then stored.

---

**NOTE**

As the calibration data is unique to each IF Assembly, any characterized IF Assembly can be fitted to any NFA. The IF Assembly is a modular replacement therefore there is no re-programming required.

---

## **Setting up and Using the VEE Program**

To run the VEE program you must first install the Agilent VEE run time environment on a PC.

---

**NOTE**

You need an HP/Agilent GPIB card installed in your PC with the correct IO libraries installed.

In the IO library, set the address to Logical Unit 7. If you do not have Agilent IO libraries installed, install them using the `iolib.exe` file provided on the CD in directory `IO Libraries`.

### **Installing the VEE Runtime Environment**

Use the following procedure to set up the VEE run time environment on your PC. This enable you to run the `if_diag.vxe` program.

- Step 1.** Insert the CD in your PC's disc drive.
- Step 2.** Go to the directory `VEE Runtime Files`.
- Step 3.** Double click the `Setup.exe` file.
- Step 4.** Follow the on-screen instructions.
- Step 5.** Ensure the NFA is powered on and a GPIB cable is connected from the PC.
- Step 6.** Ensure the NFA address is set to 8.
- Step 7.** Go to the directory `IF Diag`.
- Step 8.** To run the program double click the `if_diag.vxe` file

Your PC display is similar to Figure 1-20.

**Figure 1-20** Typical VEE display at Initial Set Up.



**Step 9.** Follow the troubleshooting procedure IF Gain Control Check, Bandwidth Shape Check, and/or Noisy Assembly Check.

**Step 10.** To exit the program click `Quit`

### Running the VEE program

To run the program on subsequent occasions double

**Step 1.** Insert the CD in your PC's disc drive.

**Step 2.** Ensure the NFA is powered on and a GPIB cable is connected from the PC.

**Step 3.** Ensure the NFA address is set to 8.

**Step 4.** Go to the directory `IF Diag`.

**Step 5.** To run the program double click the `if_diag.vxe` file

Your PC display is similar to Figure 1-20.

**Step 6.** Follow the troubleshooting procedure IF Gain Control Check, Bandwidth Shape Check, and/or Noisy Assembly Check.

**Step 7.** To exit the program click `Quit`

---

---

## **2 Troubleshooting the Front End and RF Sections**

---

## What You Will Find in This Chapter

This chapter provides information on troubleshooting the RF and the front end sections of the analyzer. It explains how to isolate problems and provides procedures for troubleshooting common failures.

### Recommended Test Equipment

To run the tests in this chapter you need the following test equipment.

**Table 2-1** Recommended Test Equipment

Equipment Description	Critical specification for equipment substitution	Model
Spectrum Analyzer	Frequency Range: 10 MHz to 26.5 GHz Frequency Accuracy (CW): 0.02% Power Level Range: -55 dBm	E4407A
Synthesized Sweeper	Frequency Range: 10 MHz to 26.5 GHz Frequency Accuracy (CW): 0.02% Power Level Range: -55 dBm	83620/30/40/50B

### Recommended Connector Torque Settings

**Table 2-2** Recommended Torque Settings

Type	Description
Precision 7mm	12 lb-in (136 N-cm.)
Precision 3.5mm	8 lb-in (90 N-cm)
SMA	5 lb-in (56 N-cm) Use the SMA wrench to connect male SMA connectors to female precision 3.5mm connectors. Connections of male precision 3.5mm. connectors to female SMA connectors can be made with the precision 3.5mm torque wrench (8 lb-in).
Type-N	Type-N connectors may be connected finger tight. If a torque wrench is used, 12 lb-in (136 N-cm) is recommended.

## Checking the Measurement Path

You can use the following tests in the *Calibration and Performance Verification Guide* or the *N2716A Service Software* to determine whether the measurement path is functioning and the NFA meets its published specifications.

- Input VSWR.
- Noise Figure Range and Accuracy.
- Gain Measurement Uncertainty.
- Instrument Noise Figure.
- Measurement Jitter.

If any of these tests fail, follow the procedure applicable to your model of NFA and measure the signal at the test points in the measurement path.

---

**NOTE**

If the measured signal fails, suspect the A8 RF section or loose interconnections within the measurement path.

---

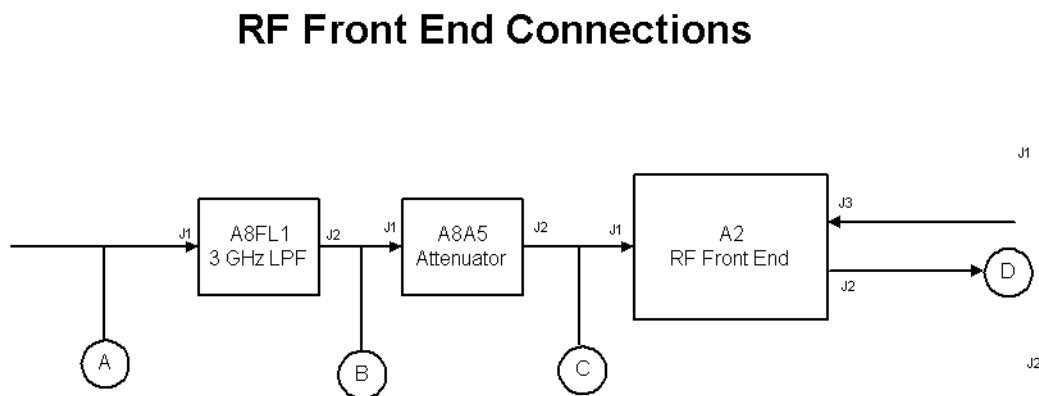
---

## Troubleshooting the A2 Front End and Input Stage

This section applies to models, N8972A and N8973A (10 MHz - 3.0 GHz). It provides techniques for isolating amplitude failures along the signal path through to the A8 assembly.

The A8FL1 Low Pass Filter, the A8A5 Attenuator, and the A2 Front End assembly can be verified as functioning correctly by performing the “RF Front End and Input Stage Verification Procedure” on page 42. The example uses a 50.0 MHz signal, you can change this to a frequency where you suspect there is a frequency problem. This procedure proves the assemblies are working.

**Figure 2-1** RF Front End Test Points



### RF Front End and Input Stage Verification Procedure

- Step 1.** Inject a 50 MHz CW signal at –20 dBm into the RF input of the analyzer.
- Step 2.** Set the NFA to 50 MHz, fixed frequency by pressing **Fixed Freq, 50, MHz**.

---

**NOTE**

Leave the default input attenuation set to 0 dB. However, the attenuator’s auto-range facility may have set the attenuation to a different value, you need to take this into account when measuring beyond point (C).

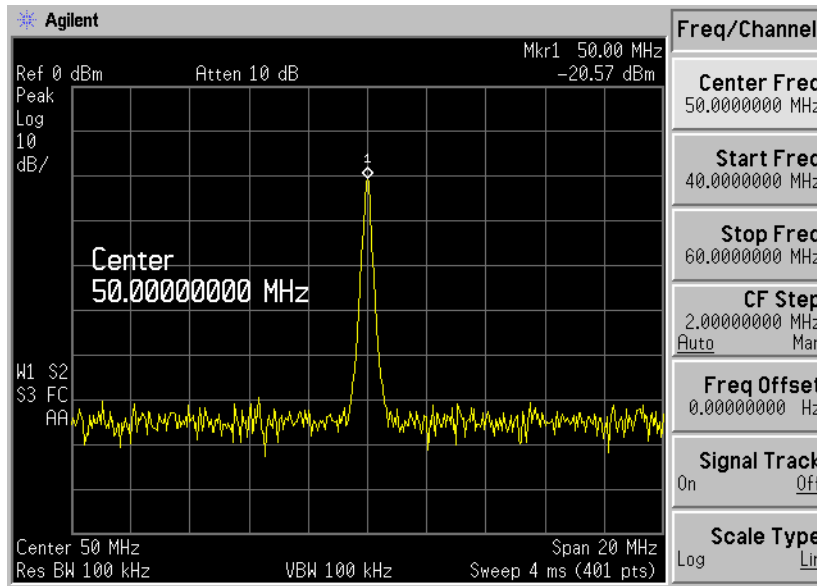
- Step 3.** Set sweep to continuous by pressing **Sweep (Cont)**.
- Step 4.** Wait 10 seconds to allow the NFA to completed a sweep.
- Step 5.** Set sweep to single by pressing **Sweep (Single)**.
- Step 6.** Disconnect the semi-rigid cables at the various test points shown in Figure 2-1 and monitor the result on a spectrum analyzer. The result can be compared with the appropriate figures at the test point.

### Test Point A

Figure 2-2 shows a typical signal at the input connector. There should be no loss or distortion through this connector. If there is any doubt replace the connector.

Figure 2-2

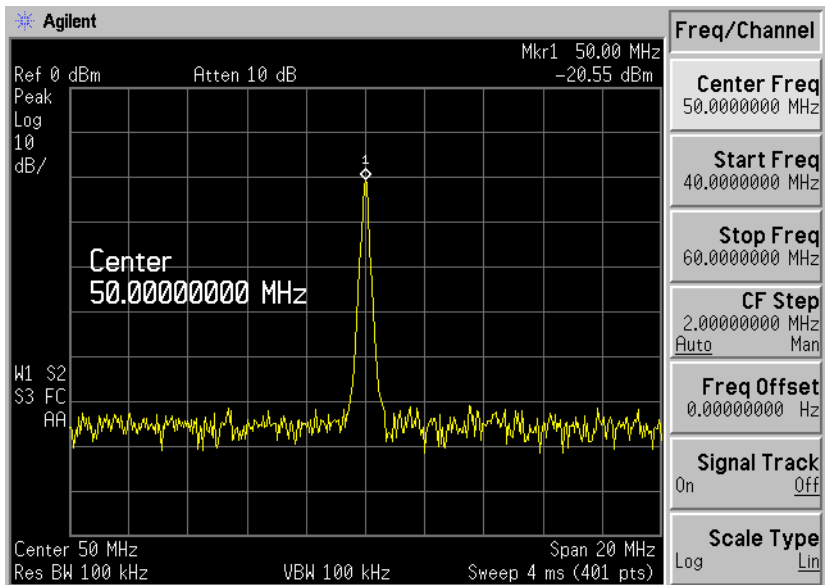
### Typical 50.0 MHz Signal at Input of A8FL1J1 - Test Point A



### Test Point B

Figure 2-3 shows a typical signal after it has passed through the Low Pass filter. There should be no loss or distortion through this filter at 50.0 MHz. You can increase the frequency value and check that the filter attenuates the signal at frequencies greater than 3.1 GHz, if you suspect this is leading to measurement problems. If there is any doubt replace the filter.

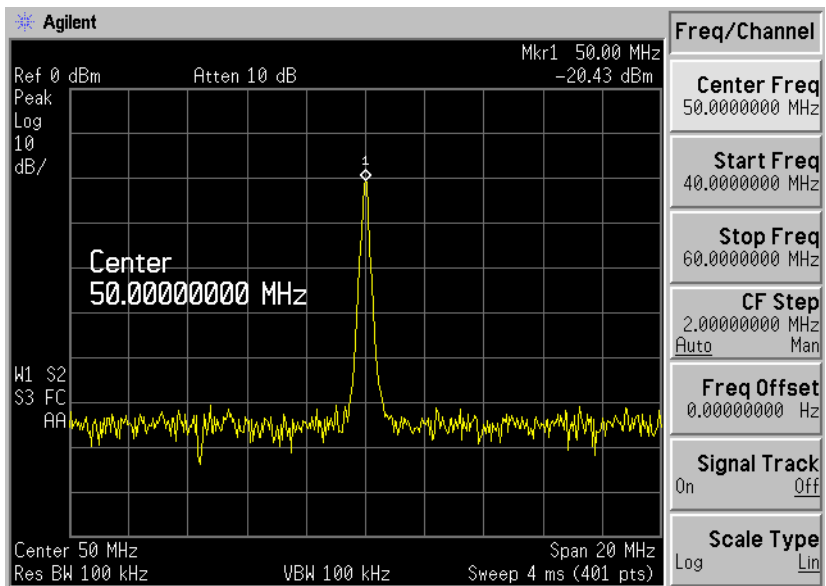
**Figure 2-3** Typical 50.0 MHz Signal at Input of A8A5J1 - Test Point B



**Test Point C**

Figure 2-4 shows a typical signal after it has passed through the Attenuator. If the attenuation on the NFA is set to 0 dB, there should be no loss or distortion through this attenuator at 50.0 MHz. You can also use this test point to verify the attenuator is working correctly. A description of the process is provided in “Verifying the RF Input Attenuator Driver Functionality” on page 77 and this needs modified when it is applied to this test point. If there is any doubt replace the attenuator.

**Figure 2-4** Typical 50.0 MHz Signal at Input of A2J1 - Test Point C



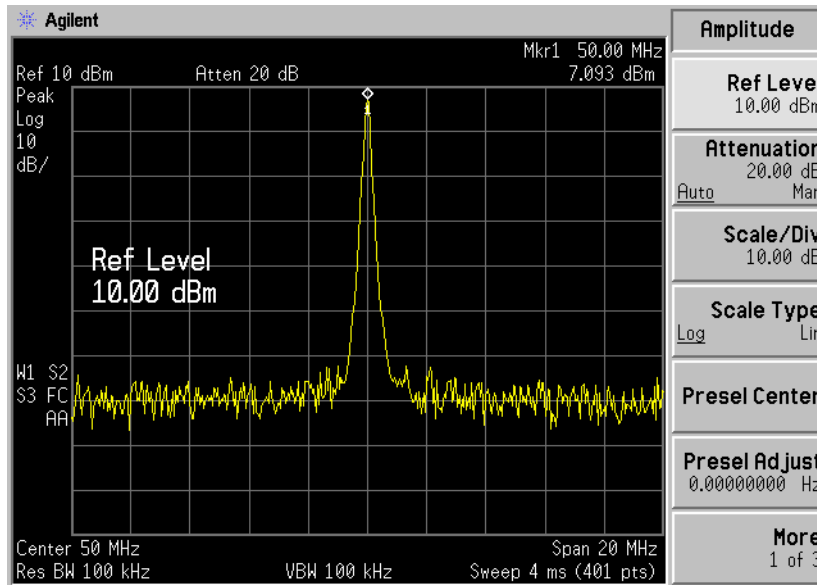


### Test Point D

Figure 2-5 shows a typical signal after it has passed through the RF Front End. If the attenuation on the NFA is set to 0 dB, there should be gain through the Front End of approximately 25 dB. If there is any doubt replace the Front End.

Figure 2-5

Typical 50.0 MHz Signal at Output of A2J2 - Test Point D



## Troubleshooting the A3 Microwave Front End, A2 Front End, and Input Stage

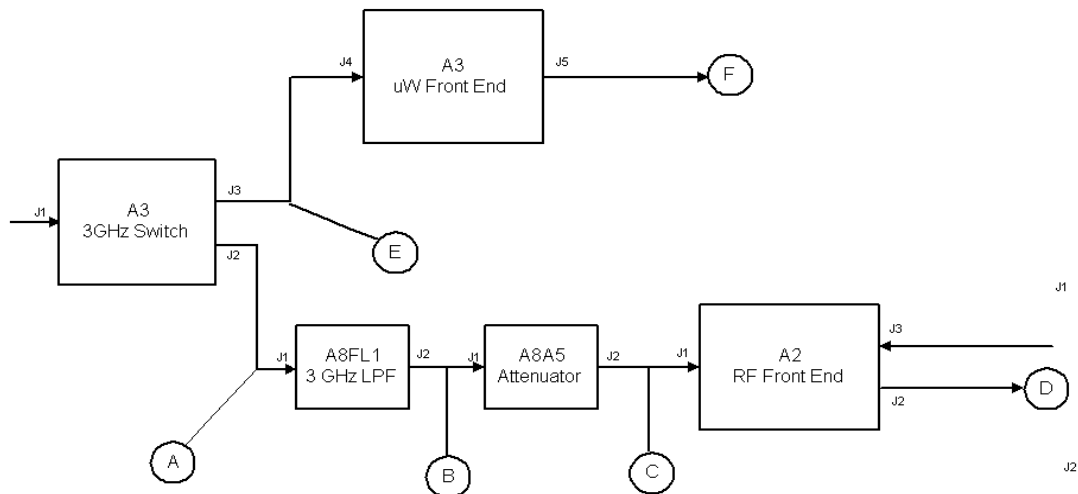
This section applies to models, N8974A and N8975A (10 MHz - 26.5 GHz). It provides techniques for isolating amplitude failures along the signal path through to the A8 assembly.

The A8FL1 Low Pass Filter, the A8A5 Attenuator, and the A2 Front End assembly can be verified as functioning correctly by performing the “RF Front End and Input Stage Verification Procedure” on page 42. The example uses a 50.0 MHz signal, you can change this to a frequency where you suspect there is a frequency problem. This procedure proves the assemblies are working.

**NOTE** The A3 microwave front end assembly has a fan, ensure this is turning when the NFA is switched on.

**Figure 2-6** Microwave Models Front End Points

### RF/uW Front End Connections



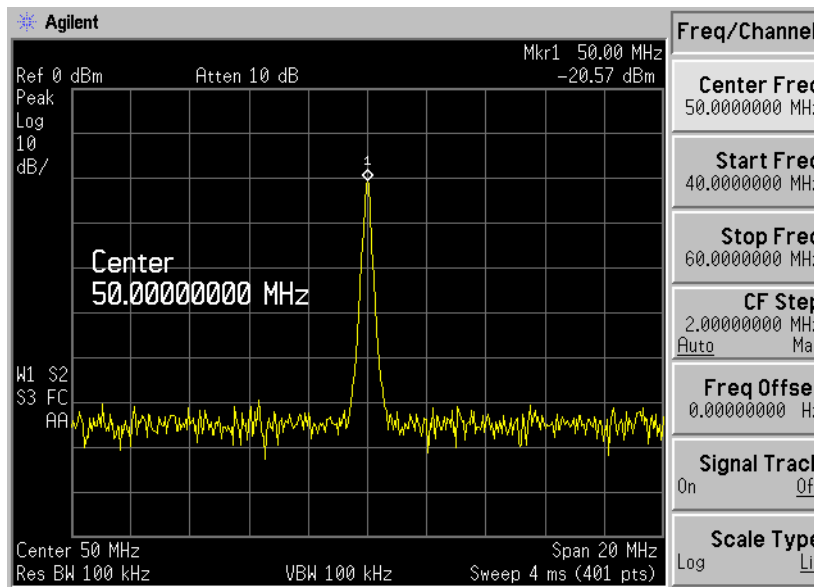
## RF Front End and Input Stage “Quick Check” Verification Procedure in Low Band

- Step 1.** Inject a 50 MHz CW signal at  $-20$  dBm into the RF input of the analyzer.
- Step 2.** Set the NFA to 50 MHz, fixed frequency by pressing **Fixed Freq, 50, MHz**. Leave the default input attenuation set to 0 dB.
- Step 3.** Set sweep to continuous by pressing **Sweep (Cont)**.
- Step 4.** Wait 10 seconds to allow the NFA to completed a sweep.
- Step 5.** Set sweep to single by pressing **Sweep (Single)**.
- Step 6.** Disconnect the semi-rigid cables at the various test points shown in Figure 2-6 and monitor the result on a spectrum analyzer. The result can be compared with the appropriate figures at the test point.

### Test Point A

Figure 2-7 shows a typical signal at the  $\leq 3.0$  GHz output connector of the switch. There should be no loss or distortion through this switch. If there is any doubt replace the A3 assembly.

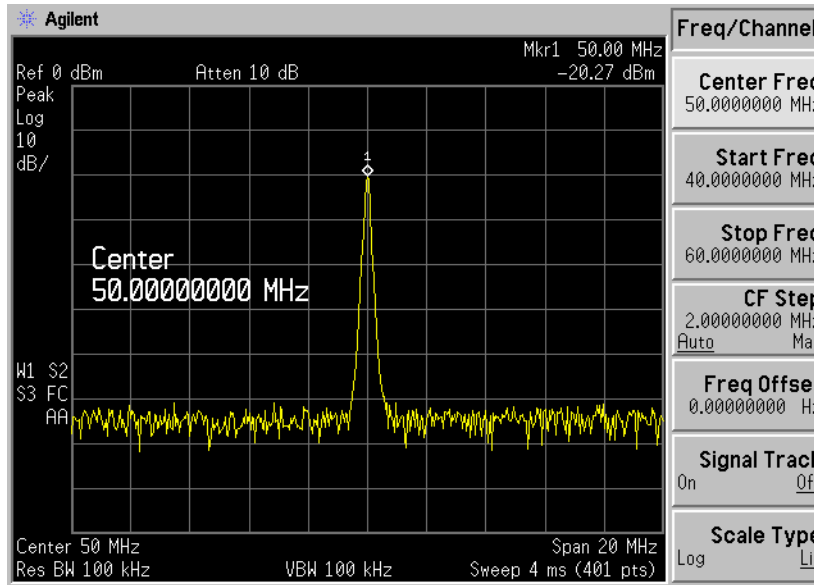
**Figure 2-7** Typical 50.0 MHz Signal at Input of A8FL1J1 - Test Point A



**Test Point B**

Figure 2-8 shows a typical signal after it has passed through the Low Pass filter. There should be no loss or distortion through this filter at 50.0 MHz. You can increase the frequency value and check that the filter attenuates the signal at frequencies greater than 3.1 GHz, if you suspect this is leading to measurement problems. If there is any doubt replace the filter.

**Figure 2-8** Typical 50.0 MHz Signal at Input of A8A5J1 - Test Point B



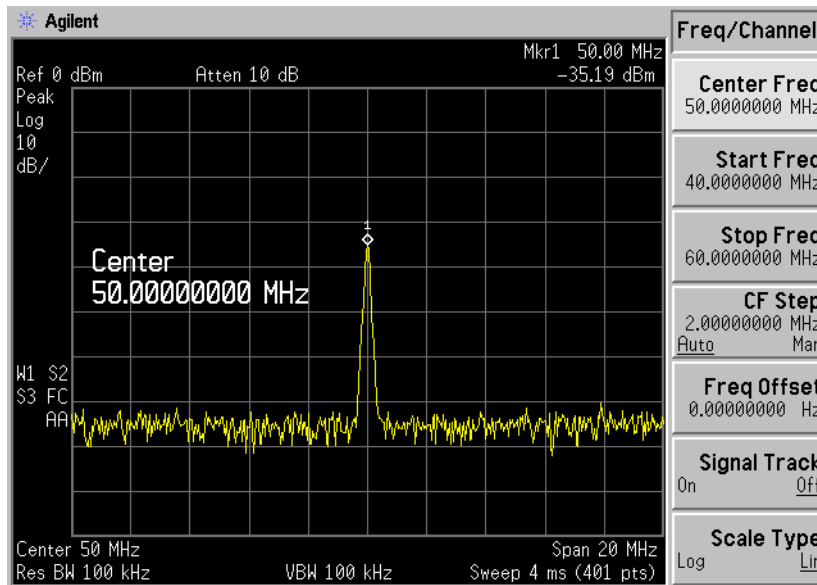
**Test Point C**

Figure 2-9 shows a typical signal after it has passed through the Attenuator. If the attenuation on the NFA is set to 0 dB, there should be no loss or distortion through this attenuator at 50.0 MHz. However, the example Figure 2-9 the NFA has auto-ranged the attenuator to 25 dB, hence the signal loss of 15 dB.

You can also use this test point to verify the attenuator is working correctly. A description of the process is provided in “Verifying the RF Input Attenuator Driver Functionality” on page 77 and this needs modified when it is applied to this test point. If there is any doubt replace the attenuator.

Figure 2-9

Typical 50.0 MHz Signal at Input of A2J1 - Test Point C

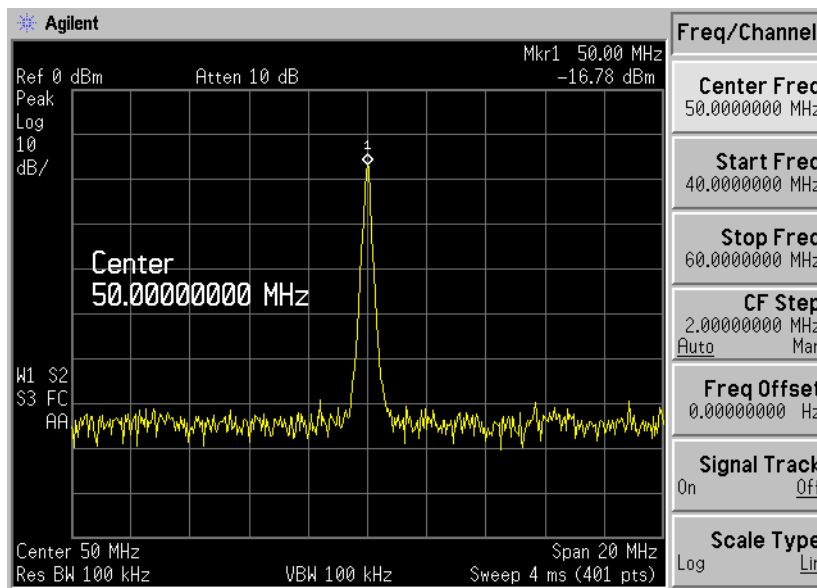


### Test Point D

Figure 2-10 shows a typical signal after it has passed through the RF Front End. If the attenuation on the NFA is set to 0 dB, there should be gain through the Front End of approximately 10 dB. If there is any doubt replace the A2 Front End.

Figure 2-10

Typical 50.0 MHz Signal at Output of A2J2 - Test Point D



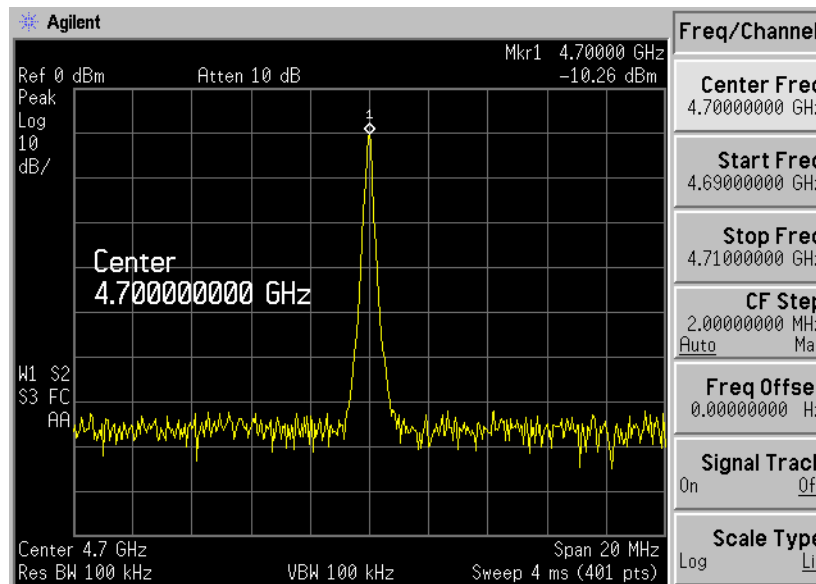
## Quick Check RF Procedure for High Bands

- Step 1.** Inject a 4.7 GHz CW signal at  $-10$  dBm into the RF input of the analyzer.
- Step 2.** Set the NFA to 4.7 GHz, fixed frequency, by pressing **Fixed Freq, 4, ., 7, GHz**.  
Ensure the input attenuation set to the default 0 dB.
- Step 3.** Set sweep to continuous by pressing **Sweep (Cont)**.
- Step 4.** Wait 10 seconds to allow the NFA to completed a sweep.
- Step 5.** Set sweep to single by pressing **Sweep (Single)**.
- Step 6.** Disconnect the semi-rigid cables at the various test points shown in Figure 2-6 and monitor the result on a spectrum analyzer. The result can be compared with the appropriate figures at the test point.

### Test Point E

Figure 2-11 shows a typical signal at the  $> 3.0$  GHz output connector of the switch. There should be no loss or distortion through this switch. If there is any doubt replace the A3 assembly.

**Figure 2-11** Typical 4.7 GHz Signal at Input of A3J4 - Test Point E

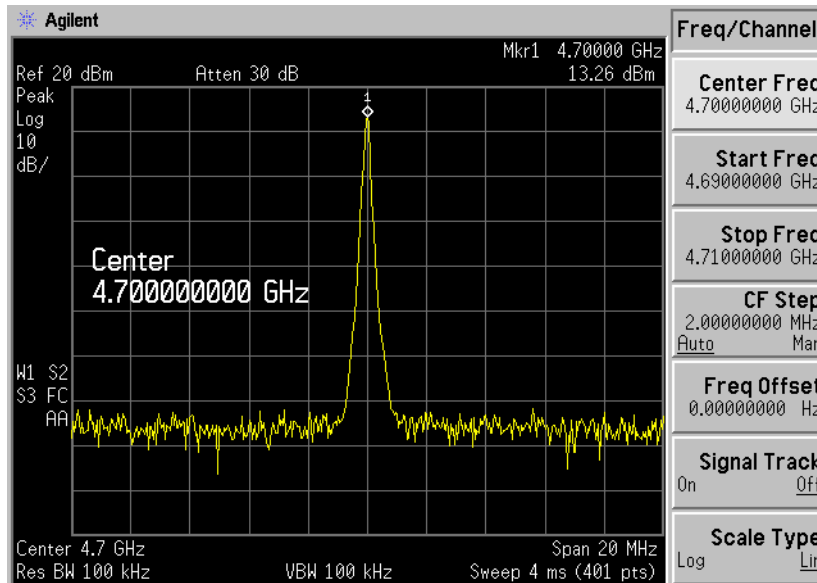


### Test Point F

Figure 2-12 shows a typical signal after it has passed through the microwave Front End. If the attenuation on the NFA is set to 0 dB, there should be gain through the Front End of approximately 25 dB. If there is any doubt replace the A3 Front End.

Figure 2-12

Typical 4.7 GHz Signal at Input of A8A6J3 - Test Point F

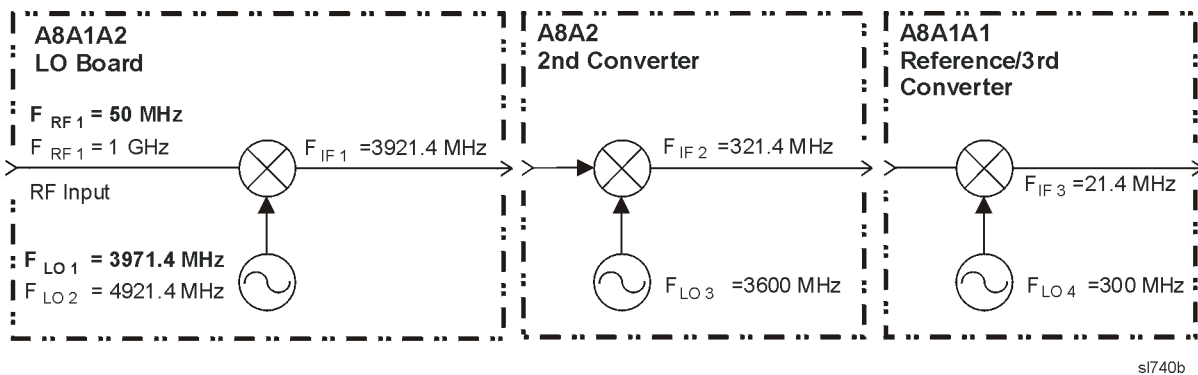


## Verifying the A8 RF Section Performance

This section applies to models, N8972A and N8973A (10 MHz - 3.0 GHz). It provides techniques for isolating amplitude failures along the signal path.

The RF section downconverts the NFA's input energy to the final IF of 21.4 MHz. You can troubleshoot the RF section by injecting a 50.0 MHz CW signal at a power level of -20 dBm to the RF input of the NFA. The 21.4 MHz downconverted IF signal is the input level minus the input attenuation. There are three conversions made in the NFA. Refer to Figure 2-13 for two examples of downconversion: one with an input frequency of 1.0 GHz and one with an input frequency of 50.0 MHz.

Figure 2-13 Downconversion Examples in the RF Section



### Quick A8 Troubleshooting Procedure

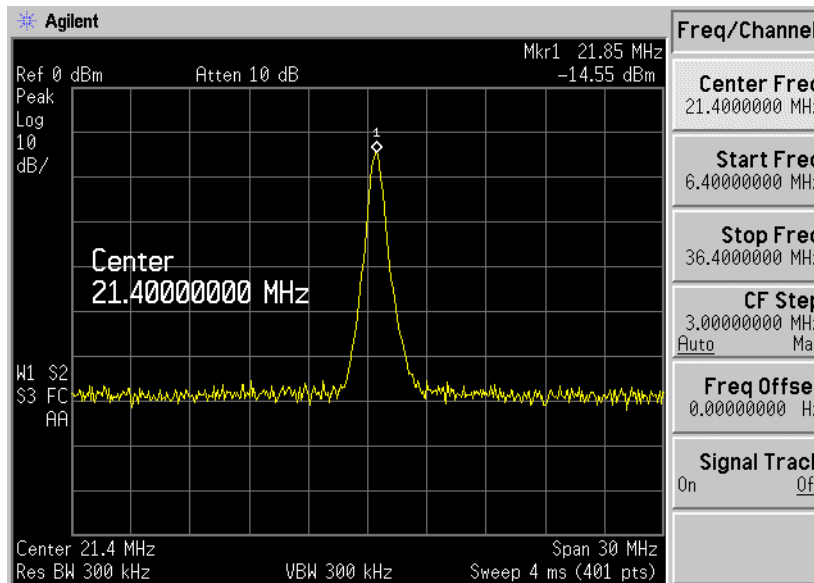
Use this procedure to quickly verify if the A8 is working. If this fails go to the “Detailed A8 RF Troubleshooting Procedure” on page 54 for more troubleshooting information.

- Step 1.** Inject a 50 MHz CW signal at -20 dBm into the analyzer's RF input.
- Step 2.** Set the NFA to 50 MHz, fixed frequency by pressing **Fixed Freq, 50, MHz**. Leave the default input attenuation set to 0 dB
- Step 3.** Set sweep to continuous by pressing **Sweep (Cont)**.
- Step 4.** Wait 10 seconds to allow the NFA to completed a sweep.
- Step 5.** Set sweep to single by pressing **Sweep (Single)**.
- Step 6.** Disconnect the flexible gray cable (W31) going into the A7A5 IF assembly at A7A5J2.
- Step 7.** Connect a calibrated spectrum analyzer to this flexible gray cable (W31) and measure the 21.4 MHz output from the RF section.

If this is operating properly, the signal out of the RF section should be similar to Figure 2-14 spectrum analyzer's display showing a 21.4 MHz at -15 dBm signal.



**Figure 2-14** Typical 21.4 MHz RF Output to IF Input - A7A5J2




---

**NOTE** If your signal level is too high or too low, check the input attenuation using the process described in “Verifying the RF Input Attenuator and the Second Converter Switch Logic” on page 76. The signal amplitude problem may be the result of a defective A8A5 input attenuator or the attenuator logic from A8A1A1 Reference/Third Converter.

---

**Another Quick Check using the 10.0 MHz Out Frequency Reference Accuracy Test**

If you are using the *Calibration and Performance Verification Guide* or the *N2716A Service Software*, run the *10.0 MHz Out Frequency Reference Accuracy Test* to determine whether the RF is functioning within its published specification. Figure 2-22 shows a typical 10.0 MHz signal.

---

**NOTE** Ensure the NFA has been allowed to warm up for 60 minutes.

If the signal is not present check the RF assembly by performing the “Quick A8 Troubleshooting Procedure” on page 52 to verify this suspicion.

If the signal is out of specification, run the *10.0 MHz Out Frequency Reference Adjustment* to perform the adjustment.

### Detailed A8 RF Troubleshooting Procedure

Use this procedure to isolate the failing assembly, use the instrument settings as stated in “Quick A8 Troubleshooting Procedure” on page 52, then refer to Table 2-3, Figure 2-15, and Figure 2-16 to measure the measurement points throughout the RF section. The Measurement Point column of the Table 2-3 corresponds to the points shown in Figure 2-15, and Figure 2-16. The Expected Measured Signal column references figures that illustrate the signal expected at that measurement point.

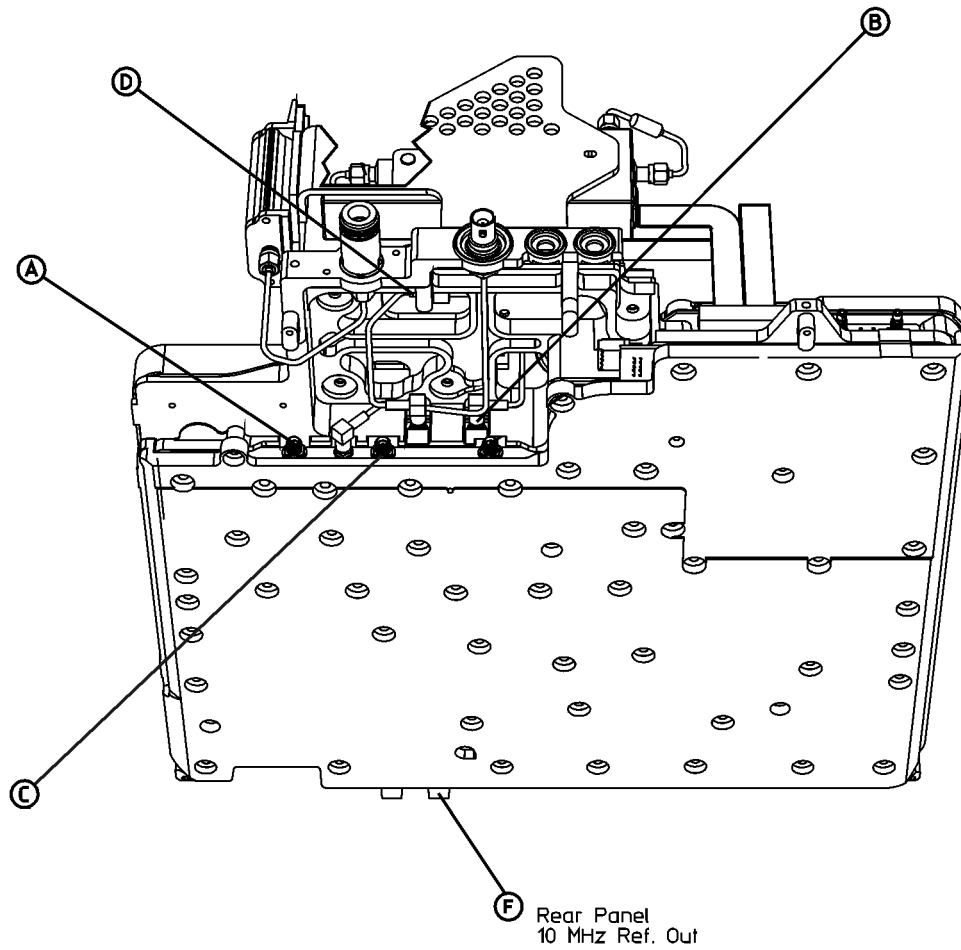
**Table 2-3 RF Section Measurement Points**

Signal Description	Measurement Point <sup>a</sup>	Expected Frequency	Expected Level	Expected Measured Signal <sup>b</sup>	Notes
first IF Output	A	3921.4 MHz	-18.2 dBm	Figure 2-17	A8A1A2 has ~3.2 dB of loss.
second IF Output	B	321.4 MHz	-23.5 dBm	Figure 2-18	A8A2 has ~4.5 dB of loss.
RF Input	C	50 MHz	-16.0 dBm	Figure 2-19	A2 has ~5 dB of gain.
second LO Input	D	600 MHz	+3 dBm	Figure 2-20	Out of A8A1A1 (through A7A9 with Option 120)
second LO Multiplied	E Block Diagram only	3600 MHz	-16.0 dBm	Figure 2-21	Out of A8A2J5 LO Test Port
10 MHz Reference	F	10 MHz	+6 dBm	Figure 2-22	Rear Panel 10 MHz Ref. Out

a. To locate the measurement points, refer to Figure 2-15 and Figure 2-16.

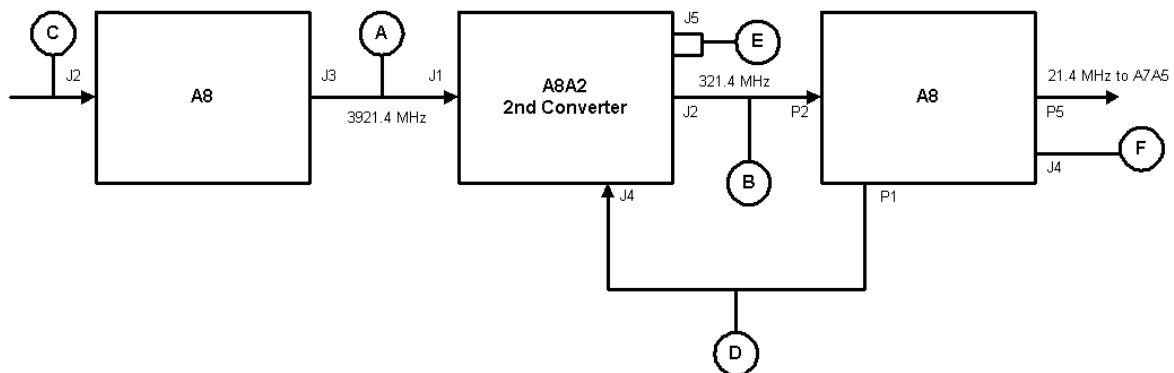
b. To see the signal expected at each measurement point, reference the figures in this column.

**Figure 2-15 RF Section Measurement Points (N8972A and N8973A)**



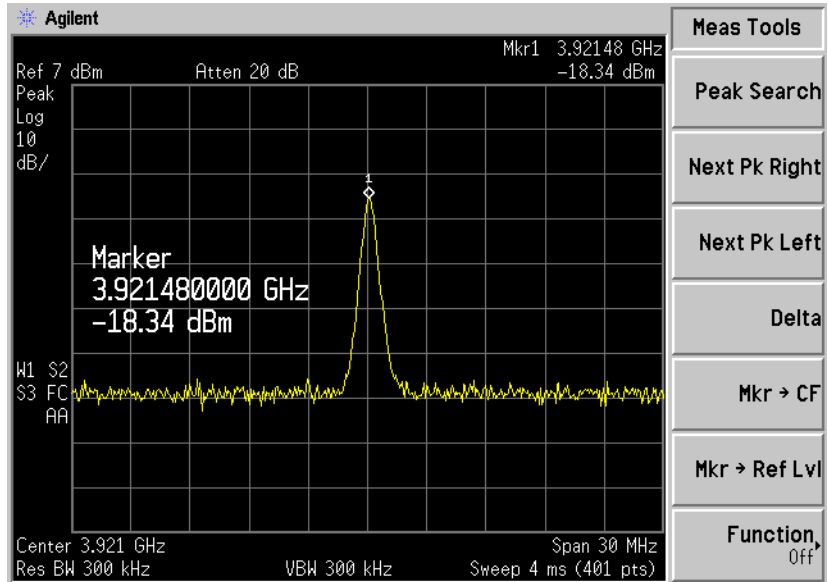
**Figure 2-16 RF Section Block Diagram (N8972A and N8973A)**

**RF Power Level Measurement Points**

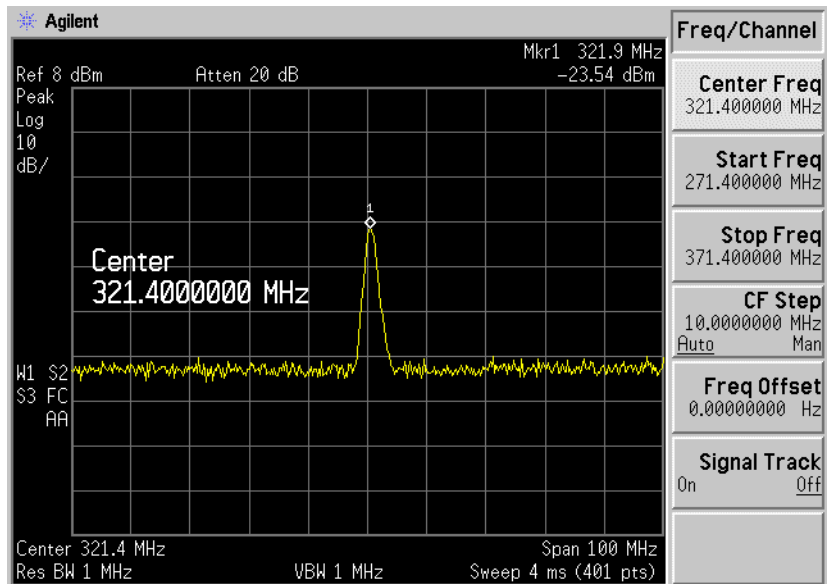


Troubleshooting the Front End and RF Sections  
**Verifying the A8 RF Section Performance**

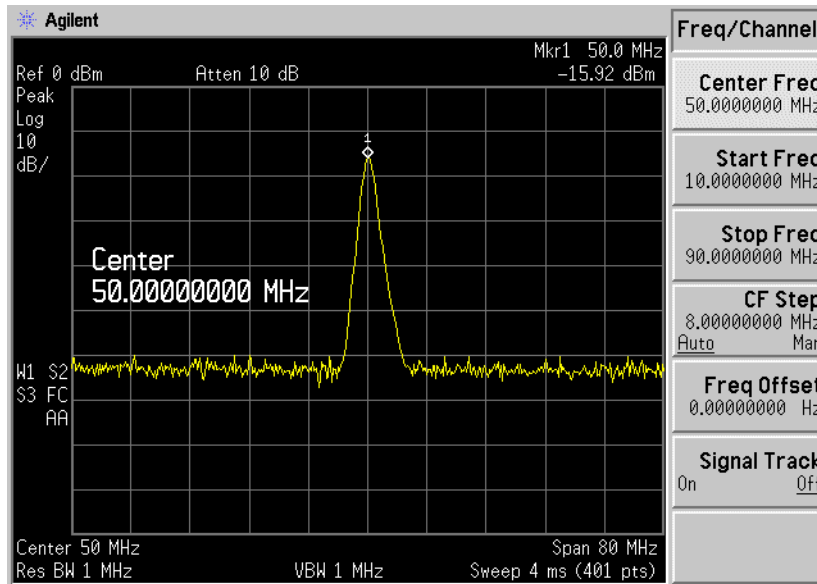
**Figure 2-17** Typical first IF Output - A8A1A2J3 - Measurement Point A



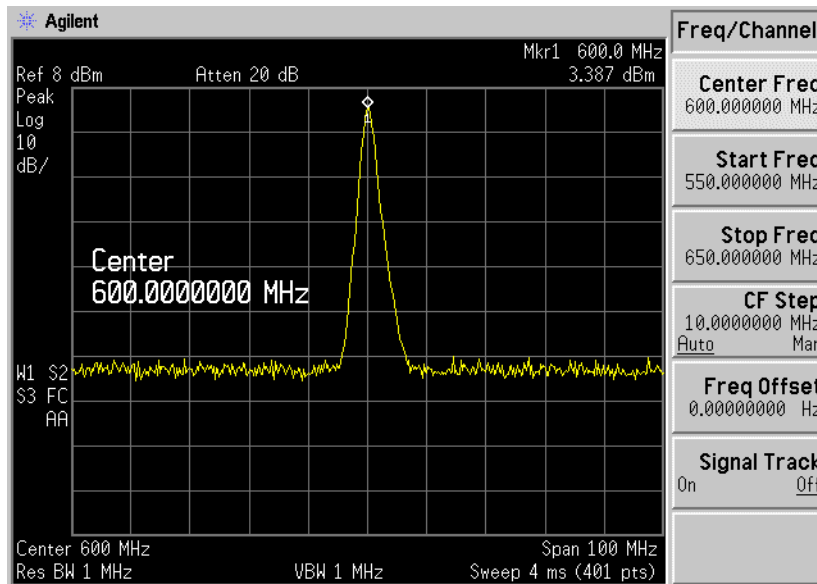
**Figure 2-18** Typical 321.4 MHz second IF Output - A8A2J2 - Measurement Point B



**Figure 2-19** Typical 50.0 MHz RF Input - A8A1A2J1 - Measurement Point C

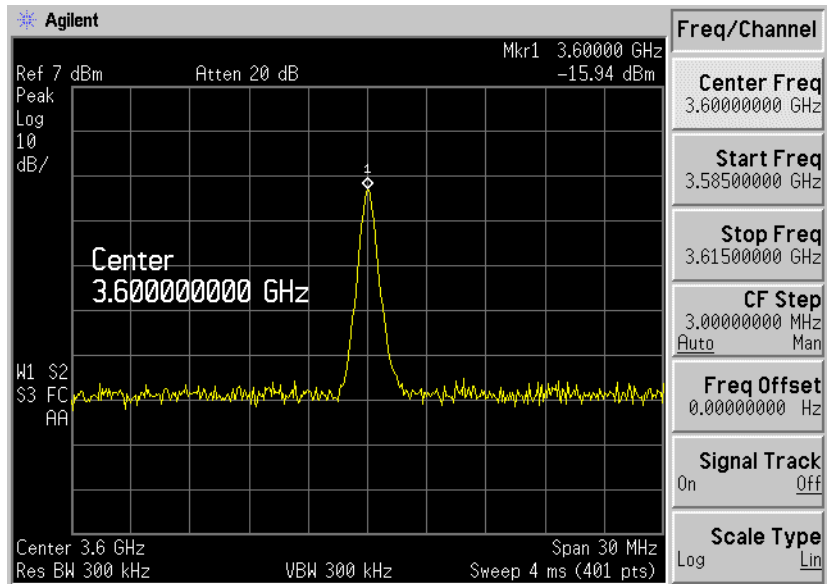


**Figure 2-20** Typical 600.0 MHz second LO Output - A8A1A1P1 - Measurement Point D

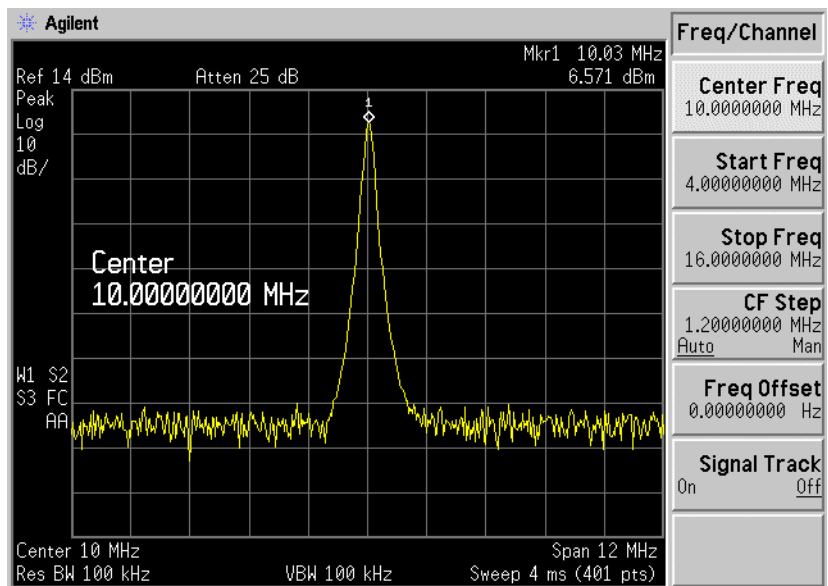


Troubleshooting the Front End and RF Sections  
**Verifying the A8 RF Section Performance**

**Figure 2-21** Typical 3600 MHz second LO Test Port - A8A2J5 - Measurement Point E



**Figure 2-22** Typical 10 MHz Reference Output- Measurement Point F



## Verifying the A8 RF Section Performance

This section applies to models, N8974A and N8975A (10 MHz - 26.5 GHz). It provides techniques for isolating amplitude failures along the signal path.

The RF section downconverts the analyzer input signal to the final IF of 21.4 MHz. You can troubleshoot the RF section by injecting a 50 MHz CW signal at -20 dBm to the RF input of the analyzer. The 21.4 MHz downconverted IF signal will be the input level minus the input attenuation. There are three conversions made in the A8 RF Assembly, as shown in Figure 2-13.

---

**NOTE** A7A3 Frequency Extension assembly replacement can only be performed at an Agilent Service Centre

---

## Quick Troubleshooting Procedure in Low Band

---

**NOTE** Low Band refers to frequencies less than or equal to 3.0 GHz.

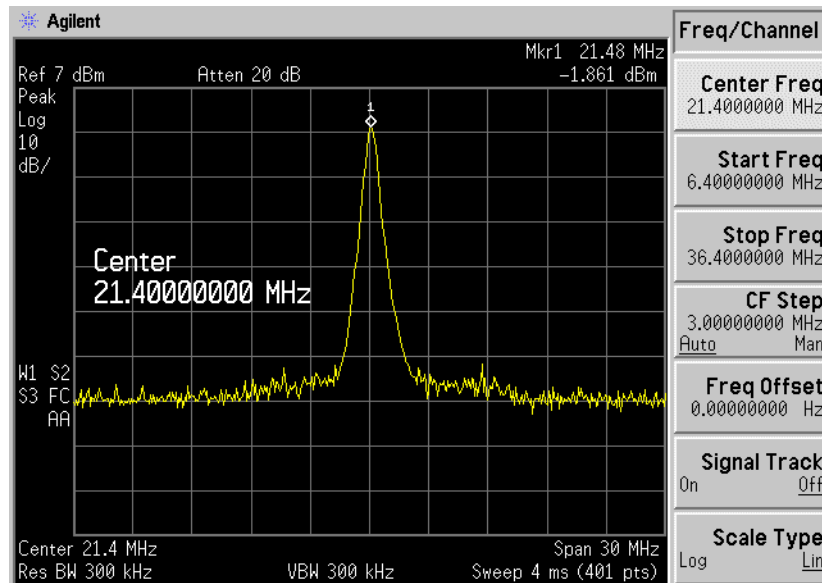
---

Use this procedure to quickly verify if the A8 is working. If this fails go to the “Detailed Troubleshooting Procedure in Low Band” on page 61 for more troubleshooting information.

- Step 1.** Inject a 50 MHz CW signal at -20 dBm into the RF input of the analyzer.
- Step 2.** Set the NFA to 50 MHz, fixed frequency by pressing **Fixed Freq, 50, MHz**. Leave the default input attenuation set to 0 dB.
- Step 3.** Set sweep to continuous by pressing **Sweep (Cont)**.
- Step 4.** Wait 10 seconds to allow the NFA to completed a sweep.
- Step 5.** Set sweep to single by pressing **Sweep (Single)**.
- Step 6.** Disconnect the flexible gray cable (W31) going into the A7A5 IF assembly at A7A5J2.
- Step 7.** Connect a calibrated spectrum analyzer to the flexible gray cable (W31) and measure the 21.4 MHz output from the RF section.

If the RF section is operating properly, the spectrum analyzer’s display should be similar to Figure 2-23 showing a 21.4 MHz at -2 dBm signal out of the RF section.

Figure 2-23 Typical 21.4 MHz third IF Output



**NOTE**

If the signal amplitude is too high or too low, check the input attenuation using the process described in “Verifying the RF Input Attenuator and the Second Converter Switch Logic” on page 76. The signal amplitude problem may be the result of a defective A8A5 input attenuator or the attenuator logic from A8A1A1 Reference/Third Converter.

**Additional Quick Troubleshooting Information**

- If you notice a frequency response problem, visually inspect the RF input connector for mechanical integrity. Read the *Calibration and Performance Verification Guide* appendix called *Caring for Connectors* for further advice.
- If the analyzer has a frequency response problem you can inject the frequency of interest, set the analyzer to that fixed frequency value, and monitor the 21.4 MHz IF signal level for abnormalities on the calibrated spectrum analyzer.
- If you have excessive loss through the RF section, see “Detailed Troubleshooting Procedure in Low Band” on page 61 to help confirm the A8 is the defective assembly.



### Detailed Troubleshooting Procedure in Low Band

Use this procedure to isolate the failing assembly. Refer to Table 2-4, Figure 2-24, and Figure 2-25 to measure the measurement points throughout the RF section. The Measurement Point column of the Table 2-3 corresponds to the points shown in Figure 2-24, and Figure 2-25. The Expected Measured Signal column references figures that illustrate the signal expected at that measurement point.

**Step 1.** Inject a 50 MHz CW signal at –20 dBm into the RF input of the analyzer.

**Step 2.** Set the NFA to 50 MHz, fixed frequency by pressing **Fixed Freq, 50, MHz**.

**NOTE**

Leave the default input attenuation set to 0 dB. However, the attenuator’s auto-range facility may have set the attenuation to a different value, you need to take this into account when making measurement as it may effect the result.

**Step 3.** Set sweep to continuous by pressing **Sweep (Cont)**.

**Step 4.** Wait 10 seconds to allow the NFA to completed a sweep.

**Step 5.** Set sweep to single by pressing **Sweep (Single)**.

**Table 2-4 RF Section Low Band Measurement Points**

Signal Description	Measurement Point <sup>a</sup>	Expected Frequency	Expected Level	Expected Measured Signal <sup>b</sup>	Notes
first IF Output	A	3921.4 MHz	–18.2 dBm	Figure 2-26	A8A1A2 has ~3.2 dB of loss.
second IF Output	B	321.4 MHz	–21.5 dBm	Figure 2-27	A8A2 has ~4.5 dB of loss.
RF Input	C	50 MHz	–16.5 dBm	Figure 2-28	Out of A8A3
second LO Input	D	600 MHz	+1 dBm	Figure 2-29	Out of A8A1A1 (through A7A9 with Option 120)
second LO Multiplied	E Block Diagram only	3600 MHz	–13.5 dBm	Figure 2-30	Out of A8A2J5 LO Test Port
10 MHz Reference	F	10 MHz	+5 dBm	Figure 2-31	Rear Panel 10 MHz Ref. Out
first LO Output	H	3971.4 MHz	0 dBm	Figure 2-32	Out of A8A1A2

- a. To locate the measurement points, refer to Figure 2-24 and Figure 2-25.
- b. To see the signal expected at each measurement point, reference the figures in this column.

Troubleshooting the Front End and RF Sections  
Verifying the A8 RF Section Performance

Figure 2-24 RF Section Low Band Measurement Points

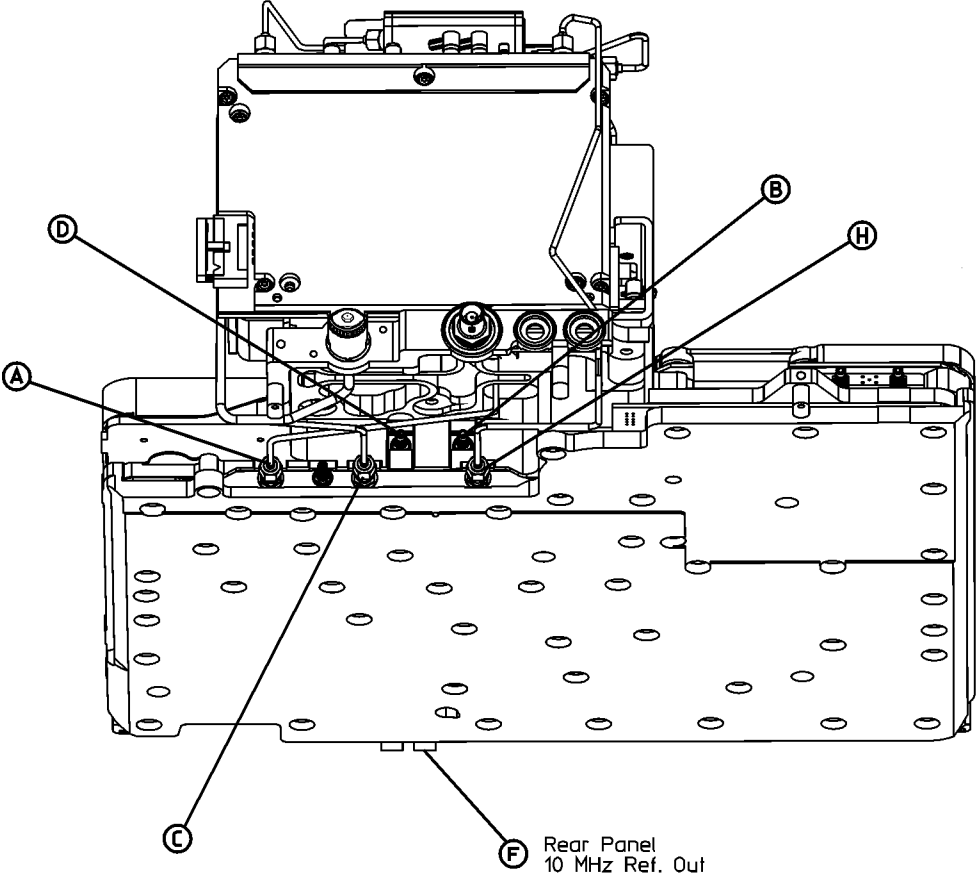
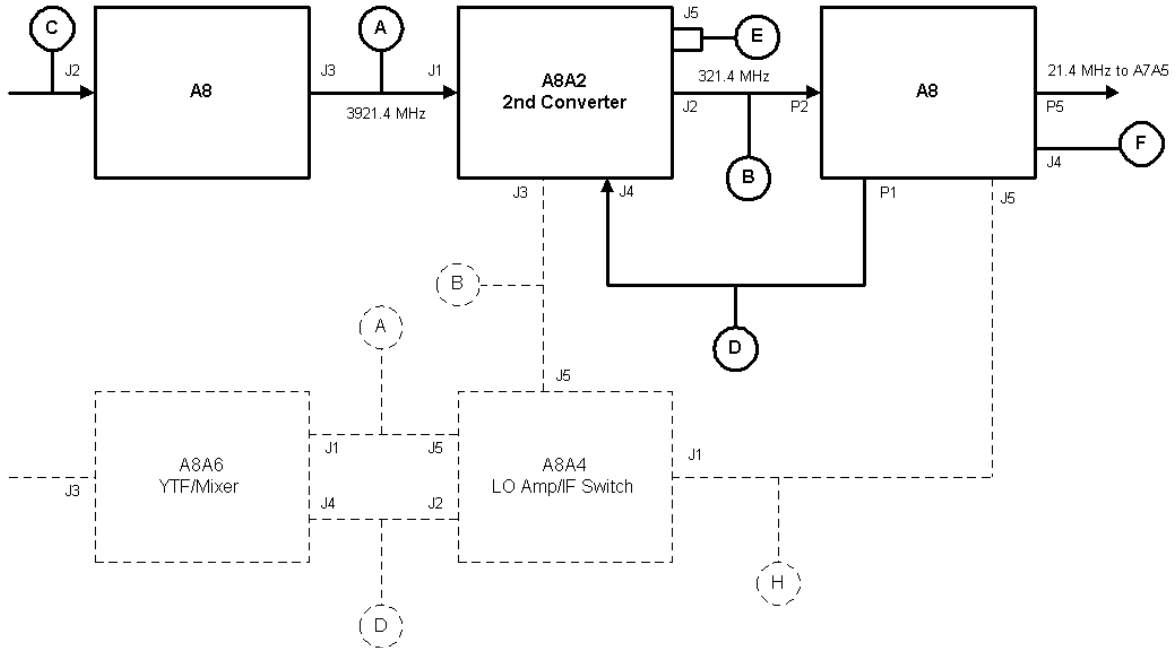


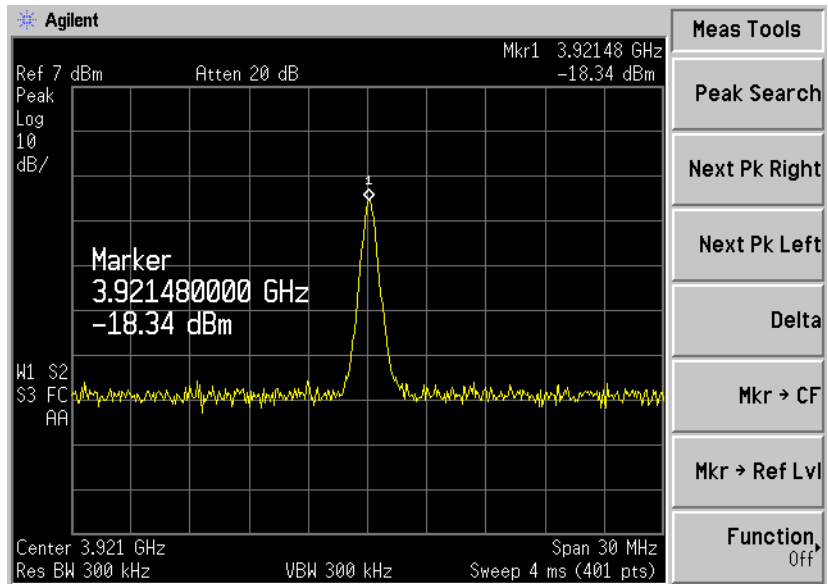
Figure 2-25 RF Section Low Band Block Diagram (N8974A and N8975A)

uW Power Level Measurement Points

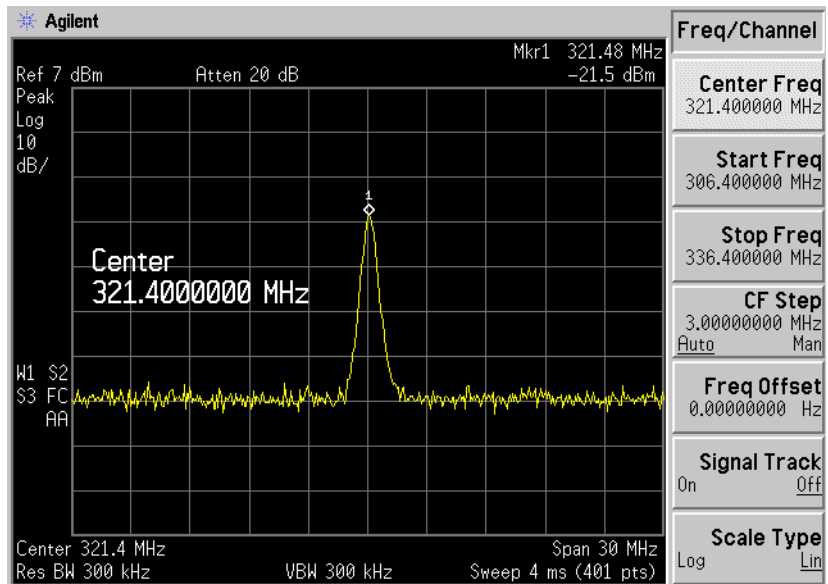


Troubleshooting the Front End and RF Sections  
**Verifying the A8 RF Section Performance**

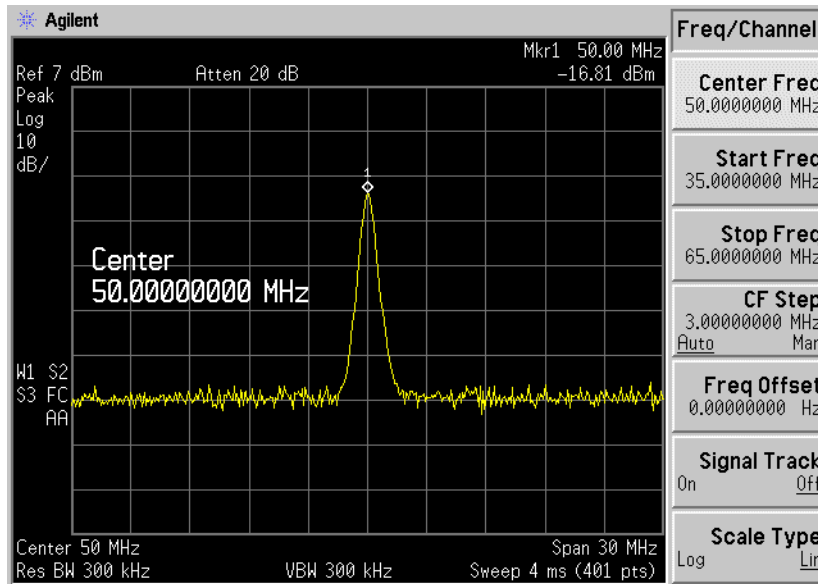
**Figure 2-26** Typical first IF Output - A8A1A2J3 - Measurement Point A



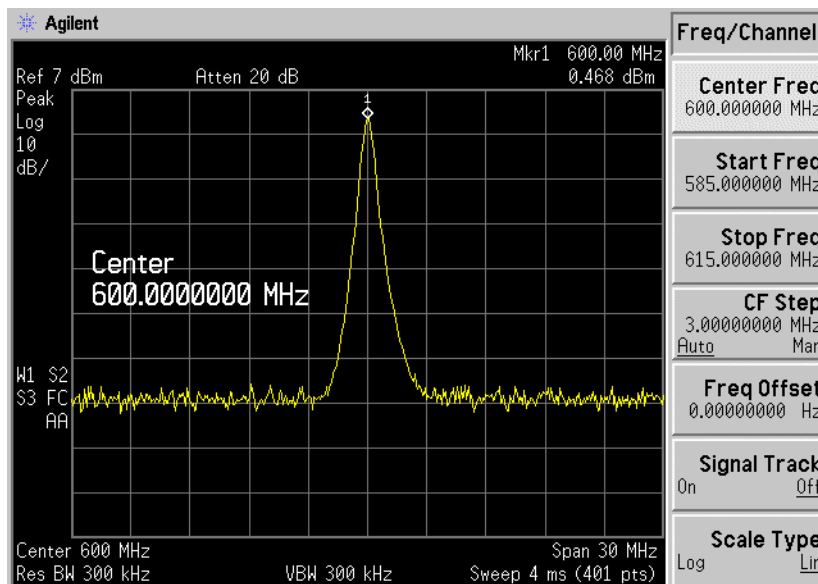
**Figure 2-27** Typical 321.4 MHz second IF Output - A8A2J2 - Measurement Point B



**Figure 2-28** Typical 50.0 MHz RF Input - Measurement Point C

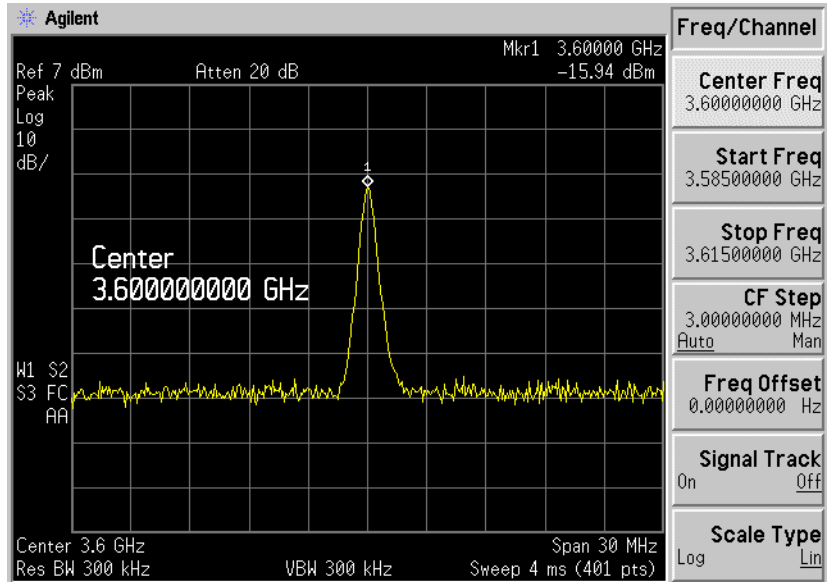


**Figure 2-29** Typical 600 MHz second LO – A8A1A1P1 - Measurement Point D



Troubleshooting the Front End and RF Sections  
**Verifying the A8 RF Section Performance**

**Figure 2-30** Typical 3600 MHz A8A2J5 LO Test Port - Measurement Point E



**Figure 2-31** Typical 10.0 MHz Reference Output – A8A1A1 - Measurement Point F

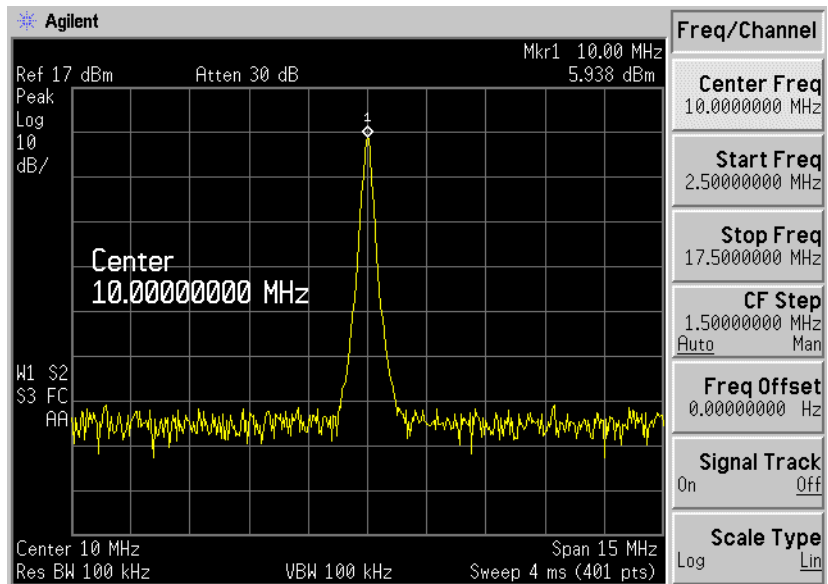
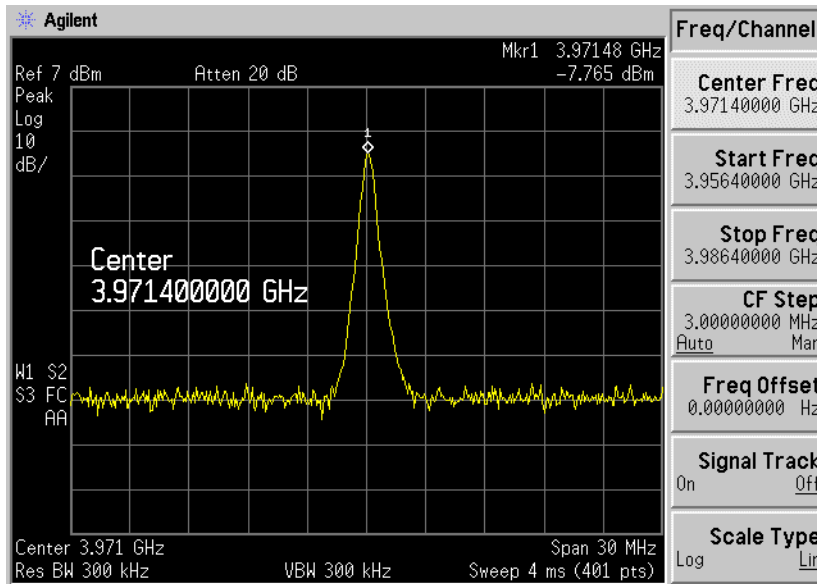


Figure 2-32 Typical first LO Output – A8A1A2J5 - Measurement Point H



## Quick Troubleshooting Procedure in High Bands

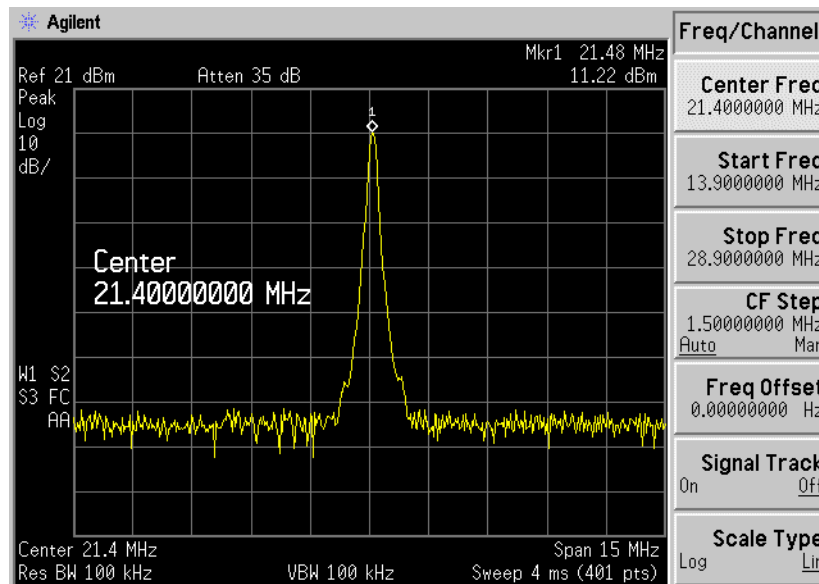
**NOTE** High Band refers to frequencies greater than 3.0 GHz.

Use this procedure to quickly verify if the A8 is working. If this fails, go to the “Detailed RF Troubleshooting for High Bands” on page 70 for more troubleshooting information.

- Step 1.** Inject a 4.7 GHz CW signal at –10 dBm into the RF input of the analyzer.
- Step 2.** Set the NFA to 4.7 GHz, fixed frequency, by pressing **Fixed Freq, 4, ., 7, GHz**.  
Ensure the input attenuation is set to the default 0 dB.
- Step 3.** Set sweep to continuous by pressing **Sweep (Cont)**.
- Step 4.** Wait 10 seconds to allow the NFA to completed a sweep.
- Step 5.** Set sweep to single by pressing **Sweep (Single)**.
- Step 6.** Disconnect the flexible gray cable (W31) going into the A7A5 IF assembly at A7A5J2.
- Step 7.** Connect a calibrated spectrum analyzer to the flexible gray cable (W31) and measure the 21.4 MHz output from the RF section.

If the RF section is operating properly, the spectrum analyzer’s display should be similar to Figure 2-33 showing a 21.4 MHz at 11 dBm signal out of the RF section.

**Figure 2-33** Typical 21.4 MHz Output - From A8A1A1 to A7A5





---

**NOTE**

If the signal amplitude is too high or too low, check the input attenuation using the process described in “Verifying the RF Input Attenuator and the Second Converter Switch Logic” on page 76. The signal amplitude problem may be the result of a defective A8A5 input attenuator or the attenuator logic from A8A1A1 Reference/Third Converter.

---

**Additional Quick Troubleshooting Information**

- If you notice a frequency response problem, visually inspect the RF input connector for mechanical integrity. Read the *Calibration and Performance Verification Guide* appendix called *Caring for Connectors* for further advice.
- If the analyzer has a frequency response problem you can inject the frequency of interest, set the analyzer to that fixed frequency value, and monitor the 21.4 MHz IF signal level for abnormalities on your calibrated spectrum analyzer.
- If you have excessive loss through the RF section, see “Detailed Troubleshooting Procedure in Low Band” on page 61 to help confirm the A8 is the defective assembly.

### **Detailed RF Troubleshooting for High Bands**

Use this procedure to isolate whether the A8A6 YTF/Mixer assembly or the A8A4 LO Amp/IF switch assembly is failing.

- Step 1.** Inject a 4.7 GHz CW signal at –10 dBm into the RF input of the analyzer.
- Step 2.** Set the NFA to 4.7 GHz, fixed frequency, by pressing **Fixed Freq, 4, .,7, GHz**.  
Ensure the input attenuation set to the default 0 dB.
- Step 3.** Set sweep to continuous by pressing **Sweep (Cont)**.
- Step 4.** Wait 10 seconds to allow the NFA to completed a sweep.
- Step 5.** Set sweep to single by pressing **Sweep (Single)**.

Refer to Table 2-5, Table 2-6, Figure 2-34, and Figure 2-35 to measure the measurement points throughout the RF section. The Measurement Point column of the Table 2-6 corresponds to the points shown in Figure 2-24, and Figure 2-25. The Expected Measured Signal column references figures that illustrate the signal expected at that measurement point.

With the instrument settings stated in the above steps, use a calibrated spectrum analyzer to measure the signals in Table 2-6.

---

**NOTE**

The first LO originating from the A8A1A2 LO board is heavily attenuated in the A8A4 LO Amp/ IF switch assembly when the analyzer is tuned to frequencies  $\leq 3.0$  GHz. At such times the A8A6 YTF/Mixer assembly is internally and electronically bypassed.

However, when the analyzer is tuned higher than 3.0 GHz, the A8A6 YTF/Mixer assembly is used for down conversion and high LO power is supplied to the A8A6 YTF/Mixer for conversion efficiency. At such times the A8A4 LO Amp/IF switch is amplifies the first LO.

The first LO modulator drive voltage originates on the A7A4 Frequency Extension board. Before changing the A8A6 YTF/Mixer assembly or the A8A4 LO Amp/IF switch, first verify the switching logic as shown in Table 2-5.

---

**Table 2-5**

**A8A6 YTF/Mixer Switching Logic**

<b>Measurement Point</b>	<b>Frequencies <math>\leq 3.0</math> GHz</b>	<b>Frequencies <math>&gt; 3.0</math> GHz</b>
A7A4J2 pin 9	0 V	5 V
A7A4J2 pin 20	5 V	0 V
A7A4J2 pin 21	5 V	0 V

---

**NOTE** A8A4 LO Amp/ IF switch assembly replacement can only be performed at an Agilent Service Centre

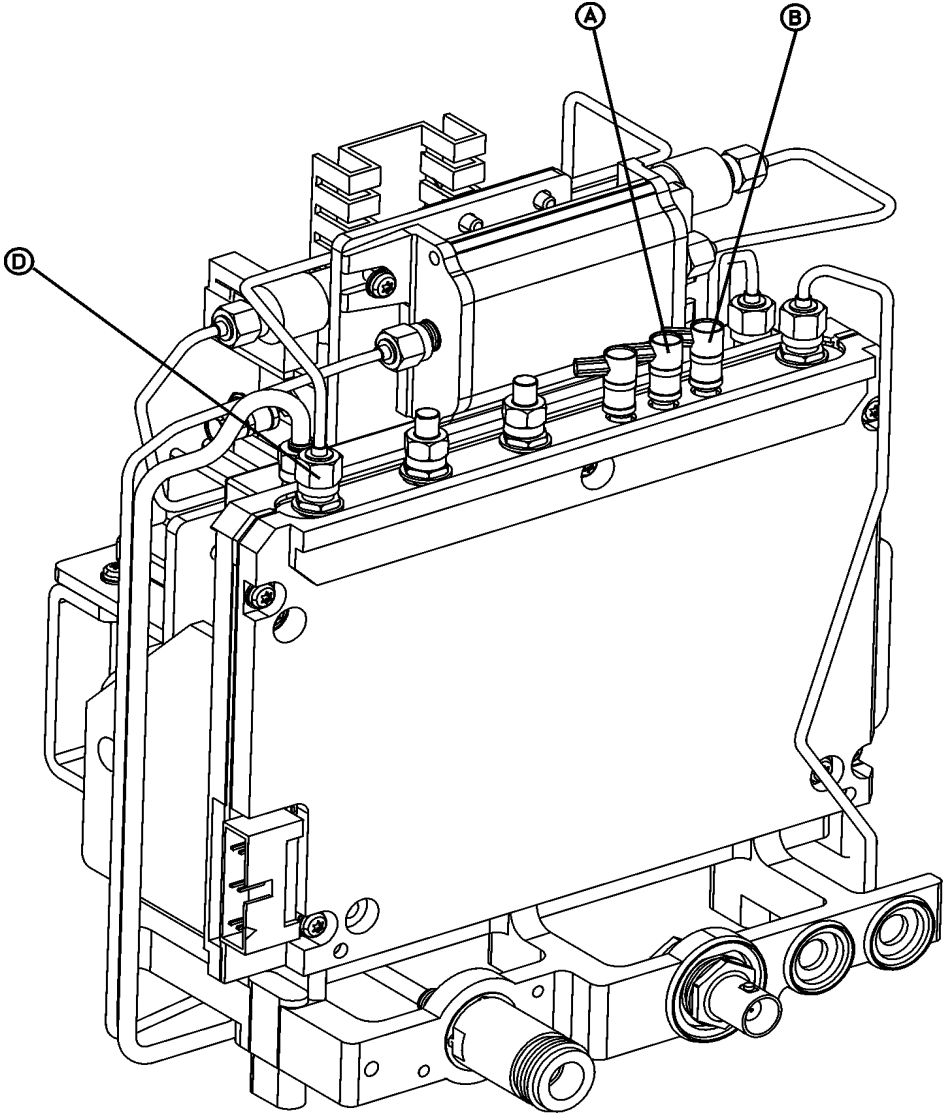
---

**Table 2-6 RF Section High Band Measurement Points**

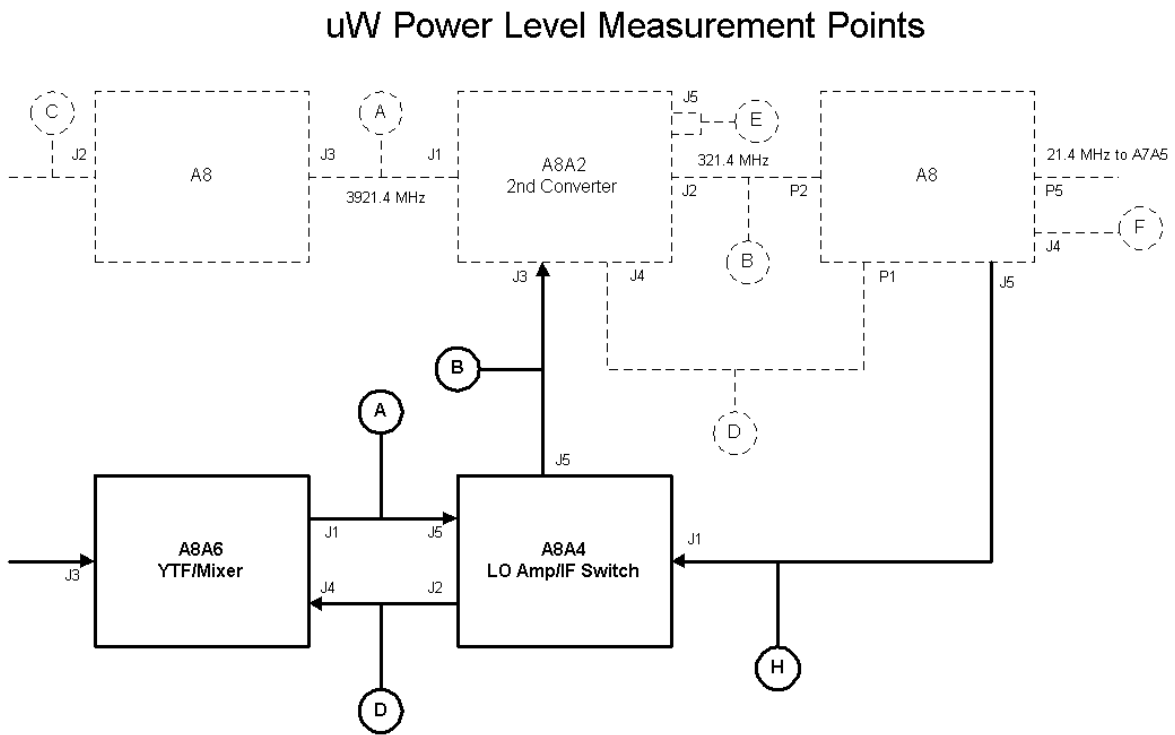
Signal Description	Measurement Point <sup>a</sup>	Expected Frequency	Expected Level	Expected Measured Signal <sup>b</sup>	Notes
first IF Output	A	321.4 MHz	2 dBm	Figure 2-36	A8A6 has ~12 dB of loss.
first IF Output	B	321.4 MHz	8 dBm	Figure 2-37	A8A4 amplifies the 321.4 MHz IF by ~6.5 dB.
first LO Output	Refer to Figure 2-24 Point C	3971.4 MHz	-8 dBm	Figure 2-38	Out of A8A1A2
first LO Output	D	5021.4 MHz	+11 dBm	Figure 2-39	Out of A8A4 in high bands ONLY. LOIS amplifies the input by ~16 dB

- a. To locate the measurement points, refer to Figure 2-34 and Figure 2-35.
- b. To see the signal expected at each measurement point, reference the figures in this column.

Figure 2-34 RF Section High Band Measurement Points

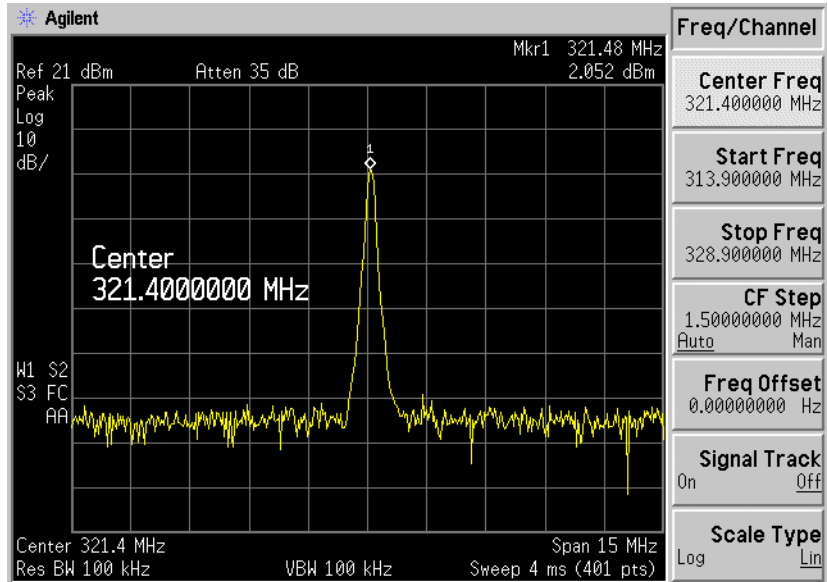


**Figure 2-35 RF Section High Band Block Diagram N8974A and N8975A**

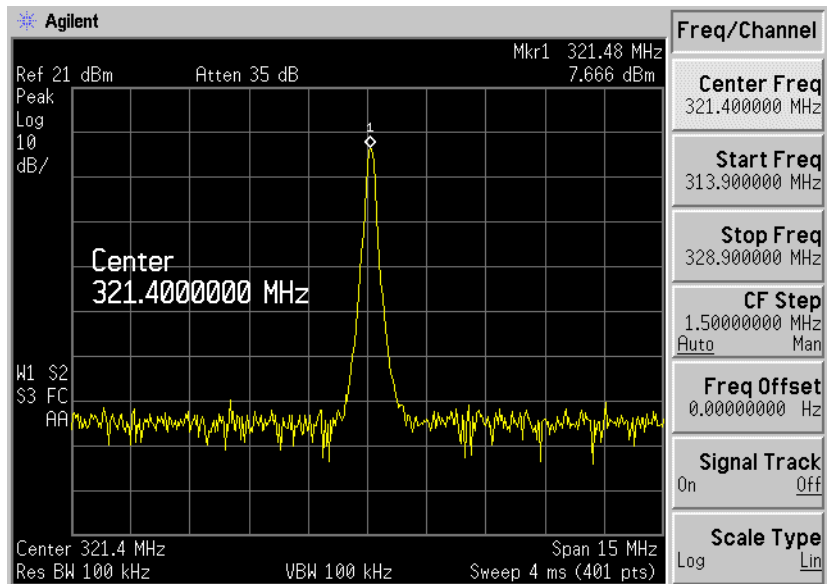


Troubleshooting the Front End and RF Sections  
**Verifying the A8 RF Section Performance**

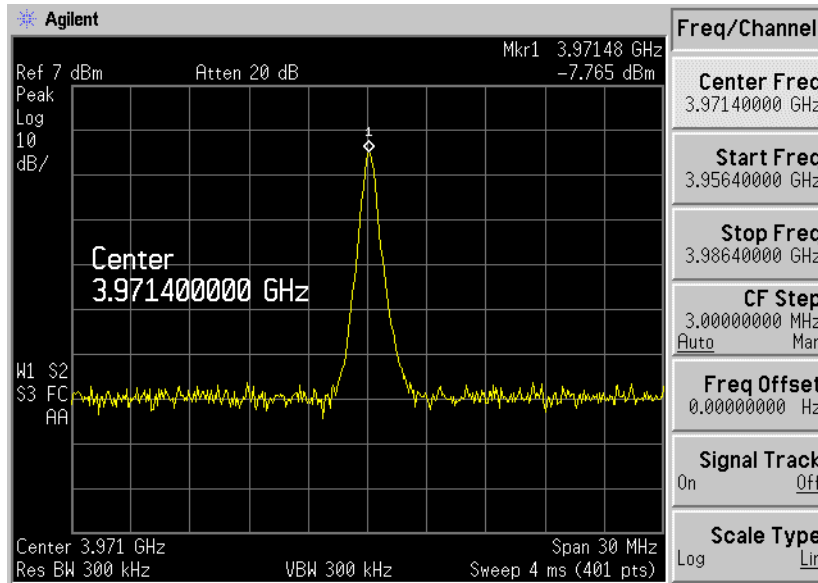
**Figure 2-36** Typical 321.4 MHz IF High Band - A8A6J1 - Measurement Point A



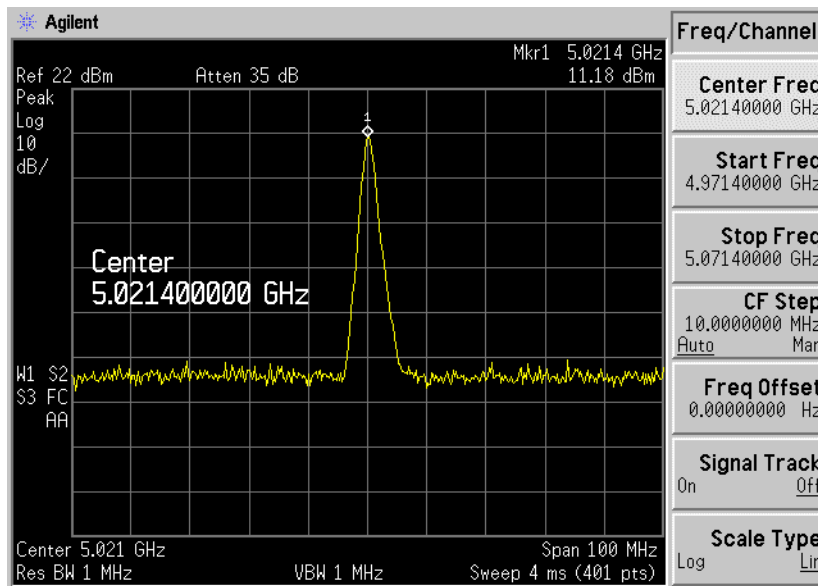
**Figure 2-37** Typical 321.4 MHz Internal IF - A8A4J7 - Measurement Point B



**Figure 2-38 Typical first LO - A8A1A2J5 - Measurement Point C**



**Figure 2-39 Typical High Band LO - A8A4J2 - Measurement Point D**

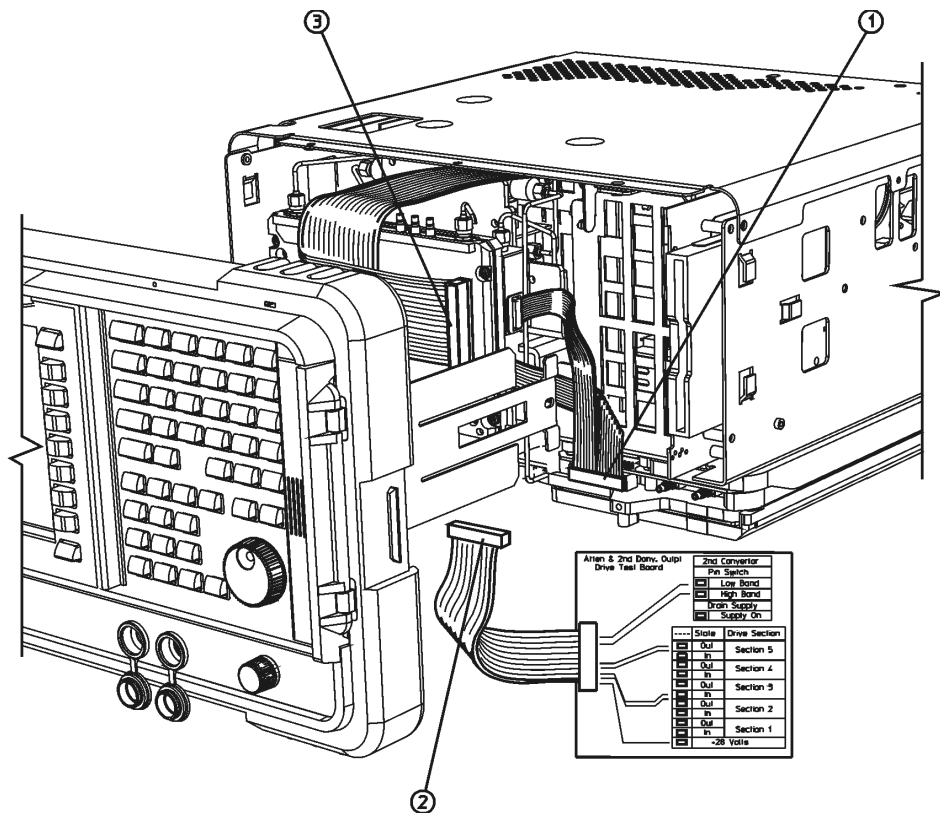


## Verifying the RF Input Attenuator and the Second Converter Switch Logic

This section shows how to verify the driver circuitry from the A8A1A1 reference third converter for the attenuator and second converter are functioning properly. It applies to all models.

- Step 1.** Remove the outer case as described in Chapter 6.
- Step 2.** Remove the front frame assembly as described in Chapter 6.
- Step 3.** Unplug the attenuator/second converter cable (1) from the A8A1A1 assembly, and replace it with the test cable (2) for the attenuator/second converter driver test board (E4401-60240), as shown in Figure 2-40.
- Step 4.** Reconnect the front-panel interface cable (3).
- Step 5.** Loosely re-attach the front frame with the test board cable dressed out the bottom of the NFA as shown in Figure 2-40.
- Step 6.** Switch on the NFA and observe the test board LEDs.

**Figure 2-40** Connecting the Attenuator/second Converter Driver Test Board



sl7106b



## Verifying the RF Input Attenuator Driver Functionality

You can verify that the correct driver signals are present by stepping the attenuator through its various settings. To access the attenuator menu keys set the NFA up as follows:

---

**NOTE** The frequency setting must be  $\leq 3.0$  GHz if you are performing the check on the N8974A and N8975A models.

---

- Step 1.** Press the **Sweep** key
- Step 2.** Press the **Manual Meas** menu key.
- Step 3.** Select the **Manual State (On)** menu keys.
- Step 4.** Press the **Press the RF Att (Fixed)** menu keys.
- Step 5.** Press the **Press the More 1 of 2** menu keys.
- Step 6.** Press the **Fixed RF Att** menu keys.
- Step 7.** As you change the attenuation settings, the LEDs on the test board illuminate according to Table 2-7.

---

**NOTE** The 0 dB to 10 dB attenuation is controlled by the A2 Front End board.

---

The state indicator shown in Table 2-8 is organized such that the attenuator sections are either switched In (Red) or switched Out (Green). The +28 V LED (Yellow) should be On whenever the instrument is powered up.

For example, if you have an attenuation setting of 35 dB, the attenuation sections 2 and 3 would be switched In (Red) and section 1 would be switched Out (Green).

**Table 2-7 Attenuator/second Converter Test Board Logic Matrix**

Attenuation Section	Attenuation Value
Section 5	n/a (always Red)
Section 4	n/a (always Green)
Section 3	5 dB
Section 2	20 dB
Section 1	10 dB

**Table 2-8 Drive Section and State Indicator**

LED	State	Drive Section
Red	In	Section 5
Green	Out	Section 4
Green	Out	Section 3
Red	In	
Green	Out	Section 2
Red	In	
Green	Out	Section 1
Red	In	
Yellow	+28 Volts	

**Verifying the second Converter Switch Logic**

You can verify the correct driver signals are present by sweeping from low band into high band. Press the **Frequency** key, change the start frequency from 10.0 MHz and sweep it to a stop frequency to 6.0 GHz. As the analyzer sweeps through 3.0 GHz, the second converter PIN switch LEDs will reflect the change as shown in Table 2-9.

---

**NOTE**

It may be helpful to use a slow sweep time.

There is only be a change from low band to high band if the instrument frequency range goes above 3.0 GHz. Therefore, for N8972A and N8973A models ( $\leq 3.0$  GHz), the low band and drain supply LEDs should remain on at all times.

**Table 2-9 Second Converter PIN Switch and Drain Supply**

Band	Pin Switch	Drain Supply
$\leq 3.0$ GHz	Low (Green)	On (Yellow)
$> 3.0$ GHz	High (Red)	Off

---

---

# **3 Error Messages**

**What You Will Find in This Chapter**

This chapter explains the error messages that can appear on the front panel display or be transmitted over an interface bus.

## **Error Messages**

The analyzer can generate various messages that appear on the display during operation. There are three types of messages.

- **Informational Messages** provide information that requires no intervention. These messages appear in the status line at the bottom of the display, in green if you have a color display. The message remains until you preset the analyzer, press **ESC**, or another message is displayed in the status line.
- **User Error Messages** appear when an attempt has been made to set a parameter incorrectly or an operation has failed (such as saving a file). These messages are often generated during remote operation when an invalid programming command has been entered. These messages appear in the status line at the bottom of the display, in yellow if you have a color display. The message remains until you preset the analyzer, press **ESC**, or another message is displayed in the status line. A summary of the last 10 error messages may be viewed by pressing, **System** then **Show Errors**. When generated by activity on the remote interface, the messages are output to the remote bus. When output to the remote interface, they are preceded by an error number. Note that the error number is not displayed under the **System, Show Errors** key sequence.
- **Pop-up Messages** indicate a condition that may require intervention. They display in the middle of the display in a framed box. The message remains until the appropriate intervention has taken place or the condition is corrected.

Error Messages  
**Error Messages**

**Informational Messages**

The following messages provide information that requires no intervention. These type of messages are in green. The information provided in brackets, for example <filename> or <name> is a variable that represents a specific input provided previously.

<filename> file loaded

The filename indicated has been successfully loaded.

<filename> file saved

The filename indicated has been successfully saved.

<filename> file copied

The filename indicated has been successfully copied.

<filename> file deleted

The filename indicated has been successfully deleted.

<filename1> file renamed to <filename2>

Filename1 has been successfully renamed to filename2.

Duplicate frequency entered in table, old  
entry replaced

A duplicate entry was made in either the ENR table, frequency list, limit line table or loss table. The previous entry is replaced with the new entry.


Each result type selected must differ from  
all others

An attempt was made to select the same result type for both of  
the two displayed result types.


Volume <name> formatted

The indicated disk has been successfully formatted.

Zoom active in graph mode only

The  key is only active when display format is set to **Graph**.

Zoom inactive when showing combined graph

The  key is not active if the display format is set to **Combined**.

User cal now valid

Previously invalidated user cal is now valid due to change of instrument parameter(s).

Invalid frequency list for measurement mode

A frequency within the frequency list cannot be used to make a measurement in the current mode.

ENR table will be extrapolated

The measurement requires ENR values beyond the limits of the existing ENR table.

User cal will be interpolated

For a corrected measurement, the measurement frequencies do not coincide with the user cal frequencies.

Memory trace invalidated

A change of instrument parameter has caused the memory trace to be invalidated (removed from screen and no longer selectable).

Maximum number of entries in table reached

The maximum number of entries in the ENR table, frequency list or limit line table has been reached.

## **Error Queues**

When a user-error condition occurs in the instrument as a result of SCPI activity, it is reported to both the front-panel display-error queue and the SCPI (remote interface) error queue. If it is a result of front-panel activity it reports to the front panel display error queue, and may also report to the SCPI error queue depending on the error. These two queues are viewed and managed separately.

Error messages have a signed error number followed by some error text in double quotes. Negative error numbers are for predefined SCPI errors, for example error -350, "Queue overflow" which is issued if an error occurs when the error queue is already full. Positive errors are instrument specific.

The query used to get the head of the error queue is `SYSTEM:ERROR:NEXT?`. It can only retrieve one error at a time.

The special error message +0, "No error" indicates that the error queue is empty. You can query the error queue as often as you like, when it is empty you just keep getting +0, "No error".

A single command or query can generate more than one error message. For this reason it is best to drain the error queue after each command or query. If not, you will lose track of what commands caused what errors.

Errors can occur that are not directly related to the last command issued. You can use status information to find out if your command generated an error. Status information can also tell you if some other type of error has occurred. However, if the status information indicates there are different types of error in the error queue, you cannot know which of the errors was caused by the last command unless it is obvious from the error itself.



**Table 3-1**                    **Characteristics of the Error Queues**

<b>Characteristic</b>	<b>Front Panel Display Error Queue</b>	<b>SCPI Remote Interface Error Queue</b>
Capacity (#errors)	10	30
Overflow Handling	Circular (rotating). Drops oldest error as new error comes in.	Linear, first-in/first-out. Replaces newest error with: -350, Queue overflow
Viewing Entries	Press: <b>System, Show Errors</b>	Use SCPI query SYSTem:ERRor?
Clearing the Queue	Press: <b>System, Show Errors, Clear Error Queue</b>	Power up Send a *CLS command Read last item in the queue

### **Error Message Format**

The system-defined error numbers are chosen on an enumerated (“1 of N”) basis. The error messages are listed in alphabetical order within each error message type section.

In this chapter, an explanation is included with each error to further clarify its meaning. The last error described in each class (for example, -400, -300, -200, -100) is a “generic” error.

Error messages appear at the bottom of the display.

## Error Messages

### Error Message Types

Events do not generate more than one type of error. For example, an event that generates a query error will not generate a device-specific, execution, or command error.

#### **-499 to -400: Query Errors**

These errors indicate that the instrument output queue control has detected a problem with the message exchange protocol described in IEEE 488.2, Chapter 6. Errors in this class set the query error bit (bit 2) in the event status register (IEEE 488.2, section 11.5.1). These errors correspond to message exchange protocol errors described in IEEE 488.2, 6.5. In this case:

- Either an attempt is being made to read data from the output queue when no output is either present or pending, or
- data in the output queue has been lost.

#### **-199 to -100: Command Errors**

These errors indicate that the instrument parser detected an IEEE 488.2 syntax error. Errors in this class set the command error bit (bit 5) in the event status register (IEEE 488.2, section 11.5.1). In this case:

- Either an IEEE 488.2 syntax error has been detected by the parser (a control-to-device message was received that is in violation of the IEEE 488.2 standard. Possible violations include a data element which violates device listening formats or whose type is unacceptable to the device.), or
- an unrecognized header was received. These include incorrect device-specific headers and incorrect or non-implemented IEEE 488.2 common commands.

#### **-399 to -300 and 201 to 799: Device-Speci fic Errors**

These errors indicate that a device operation did not properly complete, possibly due to an abnormal hardware or firmware condition. These codes are also used for self-test response errors. Errors in this class set the device-specific error bit (bit 3) in the event status register (IEEE 488.2, section 11.5.1).

The <error\_message> string for a positive error is not defined by SCPI.

**-299 to -200:  
Execution Errors**

These errors indicate that an error has been detected by the instrument's execution control block. The occurrence of any error in this class shall cause the execution error bit (bit 4) in the event status register (IEEE 488.2, section 11.5.1) to be set. One of the following events has occurred:

- A <PROGRAM DATA> element following a header was evaluated by the device as outside of its legal input range or is otherwise inconsistent with the device's capabilities.
- A valid program message could not be properly executed due to some device condition.

Execution errors shall be reported by the device after rounding and expression evaluation operations have taken place. Rounding a numeric data element shall not be reported as an execution error. Events that generate execution errors shall not generate Command errors, device-specific errors, or Query errors.

**0: No Error**

0                      No error

The queue is empty. Every error in the queue has been read or the queue was purposely cleared by power-on or \*CLS.

### **-499 to -400: Query Errors**

The instrument output queue control has detected a problem with the message exchange protocol described in IEEE 488.2, Chapter 6. Errors in this class set the query error bit (bit 2) in the event status register (IEEE 488.2, section 11.5.1). These errors correspond to message exchange protocol errors described in IEEE 488.2, 6.5.

In this case, either an attempt is being made to read data from the output queue when no output is either present or pending, or data in the output queue has been lost.

- |      |  |   |
|------|--|---|
| -430 | Query DEADLOCKED                             | Indicates that a SCPI output queue has filled, preventing further SCPI command execution, and there is no more room left in the corresponding SCPI input queue to accept a query to read from the output queue. The system automatically discards output to correct the deadlock. |
| -400 | Query Error                                  | This is a generic query error for devices that cannot detect more specific errors. The code indicates only that a query error as defined in IEEE 488.2, 11.5.1.1.7 and 6.3 has occurred.  |
| -410 | Query INTERRUPTED                            | Indicates that a condition causing an INTERRUPTED query error occurred (see IEEE 488.2, 6.3.2.7). For example, a query was followed by DAB or GET before a response was completely sent.  |
| -420 | Query UNTERMINATED                           | Indicates that a condition causing an UNTERMINATED query error occurred (see IEEE 488.2, 6.3.2.2). For example, the device was addressed to talk and an incomplete program message was received.  |
| -440 | Query UNTERMINATED after indefinite response | Indicates that a query was received in the same program message after a query requesting an indefinite response was executed (see IEEE 488.2, 6.3.7.5).   |

### **-199 to -100: Command Errors**

The instrument parser detected an IEEE 488.2 syntax error. Errors in this class set the command error bit (bit 5) in the event status register (IEEE 488.2, section 11.5.1). In this case:

- Either an IEEE 488.2 syntax error has been detected by the parser (a control-to-device message was received that is in violation of the IEEE 488.2 standard. Possible violations include a data element which violates device listening formats or whose type is unacceptable to the device.), or
- an unrecognized header was received. These include incorrect device-specific headers and incorrect or non-implemented IEEE 488.2 common commands.

**-160**            Block data error

This error, and also error -168, is generated when parsing a block data element. This particular error message is used if the device cannot detect a more specific error.

**-168**            Block data not allowed

A legal block data element was encountered, but not allowed by the device at this point in the parsing.

**-140**            Character data error

This error, as well as errors -144 and -148, are generated when parsing a character data element. This particular error message is used if the device cannot detect a more specific error.

**-148**            Character data not allowed

A legal character data element was encountered where prohibited by the device.

**-144**            Character data too long

The character data element contains more than twelve characters (see IEEE 488.2, 7.7.1.4).

**-100**            Command error

This is a generic syntax error for devices that cannot detect more specific errors. The code indicates only that a command error as defined in IEEE 488.2, 11.5.1.1.4 has occurred.

## Error Messages

### Error Messages

- 110            Command header error
- An error was detected in the header. This message is used when the device cannot detect the more specific errors described for errors -111 through -119.
- 104            Data type error
- The parser recognized a data element that is not allowed. For example, numeric or string data was expected, but block data was encountered.
- 123            Exponent too large
- The magnitude of an exponent was greater than 32000 (see IEEE 488.2, 7.7.2.4.1).
- 170            Expression error
- This error, as well as error -178, is generated when parsing an expression data element. This particular error message is used if the device cannot detect a more specific error.
- 178            Expression data not allowed
- A legal expression data was encountered, but was not allowed by the device at this point in parsing.
- 105            GET not allowed
- A Group Execute Trigger was received within a program message (see IEEE 488.2, 7.7). Correct the GPIB controller program so that the GET does not occur within a line of GPIB program code.
- 111            Header separator error
- A character which is not a legal header separator was encountered while parsing the header.

- 114           Header suffix out of range  
The value of a header suffix attached to a program mnemonic makes the header invalid.
- 161           Invalid block data  
A block data element was expected, but was invalid (see IEEE 488.2, 7.7.6.2). For example, an END message was received before the end length was satisfied.
- 101           Invalid character  
A syntactic command contains a character which is invalid for that type. For example, a header containing an ampersand, SETUP&. This error might be used in place of error numbers -114, -121, -141 and some others.
- 141           Invalid character data  
Either the character data element contains an invalid character or the particular element received is not valid for the header.
- 121           Invalid character in number  
An invalid character for the data type being parsed was encountered. For example, an alpha in a decimal numeric or a “9” in octal data.
- 171           Invalid expression  
The expression data element was invalid (see IEEE 488.2, 7.7.7.2). For example, unmatched parentheses or an illegal character.
- 103           Invalid separator  
The parser was expecting a separator and encountered an illegal character. For example, the semicolon was omitted after a program message unit.
- 151           Invalid string data  
A string data element was expected, but was invalid (see IEEE 488.2, 7.7.5.2). For example, an END message was received before the terminal quote character.

Error Messages  
**Error Messages**

- 131            Invalid suffix  
The suffix does not follow the syntax described in IEEE 488.2, 7.7.3.2, or the suffix is inappropriate for this device.
- 109            Missing parameter  
Fewer parameters were received than required for the header. For example, the \*ESE common command requires one parameter, so receiving \*ESE is not allowed.
- 120            Numeric data error  
This error, as well as error -128, is generated when parsing a data element which appears to be numeric, including non-decimal numeric types. This particular error message is used if the device cannot detect a more specific error.
- 128            Numeric data not allowed  
A legal numeric data element was received, but the device does not accept one in this position for the header.
- 108            Parameter not allowed  
More parameters were received than expected for the header. For example, the \*ESE common command only accepts one parameter, so receiving \*ESE 0,1 is not allowed.
- 112            Program mnemonic too long  
The header contains more than twelve characters (see IEEE 488.2, 7.6.1.4.1).
- 150            String data error  
This error, as well as error -158, is generated when parsing a string data element. This particular error message is used if the device cannot detect a more specific error.
- 158            String data not allowed  
A string data element was encountered, but not allowed by the device at this point in the parsing.



- 130            Suffix error
- This error, as well as errors -134 and -138, are generated when parsing a suffix. This particular error message is used if the device cannot detect a more specific error.
- 138            Suffix not allowed
- A suffix was encountered after a numeric element which does not allow suffixes.
- 134            Suffix too long
- The suffix contained more than twelve characters (see IEEE 488.2, 7.7.3.4).
- 102            Syntax error
- An unrecognized command or data type was encountered. For example, a string was received when the device does not accept strings.
- 124            Too many digits
- The mantissa of a decimal-numeric data element contained more than 255 digits excluding leading zeros (see IEEE 488.2, 7.7.2.4.1).
- 113            Undefined header
- The header is syntactically correct, but it is undefined for this specific device. For example, \*XYZ is not defined for any device.

### **-399 to -300 and 201 to 799: Device-Specific Errors**

Some device operations did not properly complete, possibly due to an abnormal hardware or firmware condition. These codes are also used for self-test response errors. Errors in this class set the device-specific error bit (bit 3) in the event status register (IEEE 488.2, section 11.5.1).

The <error\_message> string for a *positive* error is not defined by SCPI.

304 Alignment failed

The alignment failed because of one of the following reasons:

- Gain less than 0

During alignment, the measured value of the IF section gain was less than 0.

- Microwave noise greater than signal

The alignment failed at the current microwave frequency because the reading at the IF detector was greater when only the noise floor of the instrument was present compared to when the alignment noise source was on.

---

**NOTE** This error can occur if the YTF alignment has not been performed at the current operating temperature.

---

---

**NOTE** This error applies only to the N8974A and N8975A.

---

- Noise greater than signal

The reading at the IF detector was greater when only the noise floor of the instrument was present compared to when the alignment CW signal was present.

614 Bad or missing disk

The floppy is not inserted or the directory could not be read. Insert a known good disk and try again.

219 Command not valid in this model

Indicates that the command sent from the remote interface does not apply to this model number.

615	Corrupted file The file that you were trying to load is corrupt.
768	Failed to load ENR data A problem occurred when attempting to load an ENR table.
771	Failed to load Freq list A problem occurred when attempting to load a frequency list.
774	Failed to load Limit Line A problem occurred when attempting to load a limit line.
779	Failed to load Loss data A problem occurred when attempting to load loss data.
772	Failed to store Freq list A problem occurred when attempting to save a frequency list.
769	Failed to store ENR data A problem occurred when attempting to save an ENR table.
775	Failed to store Limit Line A problem occurred when attempting to save a limit line.
780	Failed to save Loss data A problem occurred when attempting to save loss data.
778	Failed to store Trace A problem occurred when attempting to save a trace.

## Error Messages

### Error Messages

- 610            File access is denied  
The file is protected or hidden and cannot be accessed.
- 604            File already exists  
Attempt to save to a file that already exists. Delete or rename the old file and try again.
- 607            File name error  
An invalid file name has been specified. Use filenames with a maximum of 8 characters (letters and digits only) and use a 3 character extension. Note that lowercase and uppercase are perceived as the same.
- 612            File does not exist  
The analyzer could not find the specified file.
- 754            File does not exist  
The state file you were trying to recall does not exist.

500

Hardware config error

A hardware configuration error occurred due to one of the following reasons:

- Unknown product number

During start-up, an attempt to match the hardware found against the NFA's product number could not be made because the product number was unknown. This is a fatal hardware configuration error.

- HW ID x in slot y not required

A card with ID x was found in slot y but for this product number is not required. This is a non-fatal hardware configuration error.

- HW ID x must be in slot y, not z

A card with ID x was found in slot z but was expected to be found in slot y for this product number. This is a fatal hardware configuration error.

- HW ID x is missing

A card with ID x was expected for this product number but was not found. This is a fatal hardware configuration error.

- Measurement not possible

An attempt was made to perform a measurement but a previous fatal hardware configuration error has occurred, preventing measurements.

- Option 'x' not installed

Software option 'x' must be enabled for this product number, but was not installed. The NFA will attempt to enable this option, requiring a power cycle. This is a fatal hardware configuration error. (until the option is reinstalled).

Error Messages  
**Error Messages**

- 300            IF autorange failed
- The IF section could not be autoranged because of one of the following:
- RF att. is fixed  
The RF front-end attenuation is fixed.
  - RF att. limit reached  
The RF front-end attenuation limit is reached.
- 313            IF over range req. RF re-range: Meas.  
restarted
- During a continuous measurement, a IF section over range condition occurred, requiring a change of RF front-end attenuation. To do this the measurement needs to be restarted.
- 302            IF PLD error;Power detector read timed out
- A read of the IF section power detector timed out.
- 603            Illegal MSDOS name given
- An invalid file name has been specified. Use filenames with a maximum of 8 characters (letters and digits only) and use a 3 character extension. Note that lowercase and uppercase are perceived as the same.
- 770            Incorrect filename, allowable extension ENR
- Attempt to save an ENR table to a file with an incorrect extension.
- 763            Incorrect filename, allowable extensions are GIF or WMF
- Attempt to save a screen image to a file with an incorrect extension.
- 776            Incorrect filename, allowable extensions LIM
- Attempt to save limit line data to a file with an incorrect extension.

- 781            Incorrect filename, allowable extension LOS  
An attempt was made to save loss data using an extension other than LOS.
- 773            Incorrect filename, allowable extension LST  
Attempt to save frequency list data to a file with an incorrect extension.
- 777            Incorrect filename, allowable extension STA  
Attempt to save the instrument state to a file with an incorrect extension.
- 762            Incorrect filename, allowable extension CSV  
Attempt to save a trace to a file with an incorrect extension.
- 782            Incorrect SNS data format  
An attempt to read SNS data failed either because the device attached was not an SNS or because the data was corrupt.
- 307            Input attenuation x dB not calibrated  
Corrected measurements have been requested and the required RF front-end attenuation setting of x dB has not been calibrated.
- 751            Instrument state may be corrupt, state has been reset to initial values  
An attempt was made to load a possibly corrupt state. The instrument state is reset to the state prior to the attempt to load. If the state load was for a user preset, then the instrument state is reset to the factory state.
- 216            Invalid baud rate  
Attempt to use invalid baud rate. Refer to the User's Guide for valid rates.

Error Messages  
**Error Messages**

- 308            Invalid frequency list for measurement mode  
A frequency within the frequency list cannot be used to make a measurement in the current mode.
- 306            Invalid input attenuation  
An attempt was made to set an invalid RF front-end attenuation limit for calibration.
- 701            Invalid printer response  
In attempting to identify the printer an invalid response was received. Check that you are using a supported printer. Be sure you are using the proper cable and that it is securely fastened.
- 301            LO GPIB error  
An LO GPIB error occurred because of one of the following:
- Did not become system controller  
An attempt to become system controller failed, possibly because another controller is present on the LO GPIB bus.
  - Need to be system controller  
To perform the required action, the NFA needs to be the system controller on the LO GPIB bus and is not because a prior attempt to become the system controller failed.
  - Controller collision  
Another controller on the LO GPIB has attempted to use the bus concurrently with the NFA.
  - Address bus timeout  
Attempted to address bus and failed — check cabling connections.
  - Write command timeout  
Attempt to write command to device failed — check device address is correct.
  - Read response timeout  
Attempt to read response from device failed - check device address is not the same as the LO GPIB address.



- 606            Media is not writable  
                 A save was attempted to a read-only device.
- 605            Media is protected  
                 A save was attempted to a write-protected device.
- 315            Microwave input attenuation x dB not  
                 calibrated  
                 Corrected measurements have been requested and the required  
                 microwave front-end attenuation setting of x dB has not been  
                 calibrated.
- 305            Mode setup error  
                 A mode setup error occurred because of one of the following:
- System input frequency out of range  
                 One or more system input frequencies are out of range. If  
                 using a frequency list, check that all entries are valid for  
                 current measurement mode.
  - External LO frequency out of range  
                 One or more external LO frequencies are out of range.  
                 Check that the LO frequency limits are set correctly and  
                 check the entered measurement frequencies and  
                 measurement mode.
  - Stop freq must be less than fixed LO freq  
                 The current measurement mode requires that the stop  
                 frequency must be less than the fixed LO frequency.
  - Start freq must be greater than start IF  
                 freq  
                 The current measurement mode requires that the start RF  
                 (input to DUT) frequency must be greater than the start IF  
                 (output from DUT) frequency.
  - LO - Stop freq must be  $\geq$  min system input  
                 freq  
                 The current measurement mode requires that the difference  
                 between the fixed LO frequency and the stop RF (input to  
                 DUT) frequency must be more than the minimum system  
                 input frequency.

## Error Messages

### Error Messages

- Start freq must be greater than fixed LO freq  
The current measurement mode requires that the start frequency must be greater than the fixed LO frequency.
- Stop IF freq must be less than fixed LO freq  
The current measurement mode requires that the stop IF (output from DUT) frequency must less than the fixed LO frequency.
- Start - LO freq must be  $\geq$  min system input freq  
The current measurement mode requires that the start RF (input to DUT) frequency must be more than the minimum system input frequency away from the fixed LO frequency.
- Stop freq must be less than stop RF freq  
The current measurement mode requires that the stop IF (output from DUT) frequency must be less than the stop RF (input to DUT) frequency.
- Start freq must be greater than start RF freq  
The current measurement mode requires that the start IF (output from DUT) frequency must be greater than the start RF (input to DUT) frequency.
- Stop RF freq must be less than fixed LO freq  
The current measurement mode requires that the stop RF (input to DUT) frequency must be less than the fixed LO frequency.
- Start freq must be greater than fixed IF freq  
The current measurement mode requires that the start RF (input to DUT) frequency must be greater than the fixed IF frequency.
- Start LO freq must be greater than fixed IF freq  
The current measurement mode requires that the start LO frequency must be greater than the fixed IF frequency.
- Stop freq must be less than fixed IF freq  
The current measurement mode requires that the stop RF (input to DUT) frequency must be less than the fixed IF frequency.

- Stop freq must be less than stop LO freq

The current measurement mode requires that the stop RF (input to DUT) frequency must be less than the stop LO frequency.

310	No entries in ENR table	A measurement was attempted or a SCPI query of an ENR table was made and there were no entries in the relevant ENR table (Common, Meas or Cal).
309	No entries in frequency list	A measurement was attempted with List frequency mode or a SCPI query of the frequency list table was made and the frequency list table is empty.
311	No entries in limit line table	A measurement was attempted using a limit line table, or a SCPI query of an limit line table was made and there were no entries in the relevant limit line table.
314	No entries in loss table	A measurement was attempted or a SCPI query of a loss table was made and there were no entries in the relevant loss table (either Before or After table).
700	No printer response	An attempt to identify the printer failed.
704	Printer interface error	An error occurred while trying to print. Make sure the printer is turned on and properly connected.
705	Printer type is none	The current printer type is set to <b>None</b> , so no print operations are possible. Change the type in the <b>Print Setup</b> menu and try again.

## Error Messages

### Error Messages

-350	Queue Overflow	There is no room in the error queue and an error occurred but was not recorded.
312	RF re-range required: Meas. restarted	<b>During a continuous measurement, a change of RF front-end attenuation was required. To do this the measurement needs to be restarted.</b>
217	RS-232 Interface Error	An error occurred on the serial interface due to one of the following reasons: <ul style="list-style-type: none"><li>• Input data overrun An error occurred on the serial interface.</li><li>• Input data parity An error occurred on the serial interface.</li><li>• Input data framing An error occurred on the serial interface.</li><li>• Output data timeout An error occurred on the serial interface</li><li>• Command input timeout An error occurred on the serial interface.</li></ul>

- 330            Self-Test Failed
- A self-test error occurred due to one of the following reasons:
- IF test [x][y] failure
  - RF test [x] failure
  - RF gain (x) out of range
  - IF gain out of range
  - RF cal x out of range amp[y]
  - RF amp[x] floor too high
  - Tuner EEPROM cal value out of range
  - IF filter offset x out of range
- 501            SNS read failure
- An attempt to read from the SNS failed. This could be due to SNS cable problems such as poor connection or disconnection while reading.
- 502            SNS write failure
- An attempt to write to the SNS failed. This could be due to SNS cable problems such as poor connection or disconnection while writing.
- 316            That must be greater than Tcold
- A spot That temperature has been specified which is not greater than Tcold temperature.
- 766            Unable to format drive
- A problem occurred when attempting to format a drive.
- 765            Unable to load file
- A problem occurred when attempting to load a file.

## Error Messages

### Error Messages

- 759            Unable to load state file into instrument with older firmware date  
A saved state file from a newer firmware revision was attempted to be loaded into an older instrument.
- 752            Unable to load state from file  
An attempt to load a state from the File Manager or through MMEM:LOAD:STAT failed. Preceding error messages may indicate the cause of failure.
- 755            Unable to load state from register  
An attempt to load a state from a register using the \*RCL command failed. Preceding error messages may indicate the cause of failure.
- 757            Unable to load user state, factory preset was done  
An attempt to perform a **User Preset** failed, so the **Factory Preset** values were used. Save a valid state into **User Preset** and try again.
- 760            Unable to query state from the remote  
A problem occurred while trying to query the instrument state as part of a \*LRN command.
- 764            Unable to save file  
A failure occurred while saving a file; the file was not saved.
- 753            Unable to save state to file  
An attempt to save a state from the File Manager or through MMEM:STOR:STAT failed. Preceding error messages may indicate the cause of failure.

- 756            Unable to save state to register
- An attempt to save a state to a register using the \*SAV command failed. Preceding error messages may indicate the cause of failure.
- 758            Unable to save user state
- An attempt to save the **User Preset** state failed.
- 761            Unable to set state from the remote
- A problem occurred while trying to set the instrument state as part of a SYST:SET command.
- 703            Unknown printer
- In attempting to identify the printer, a valid response was received but the printer is not known to the analyzer. Use the **Custom** printer menu under **Print Setup** to configure the printer.
- 702            Unsupported printer
- A printer which is recognized, but known to be unsupported was identified. This printer cannot be used with the analyzer. For example, a printer only supported by Microsoft Windows generates this error.

Error Messages  
**Error Messages**

- 303                    User cal invalidated
- The existing user cal has been invalidated because of one of the following reasons:
- Meas mode changed  
The measurement mode has been changed from that used for user cal.
  - Freq outside cal range  
The current measurement frequencies lie partially or wholly outside the range of frequencies used for user cal.
  - Fixed IF changed  
The fixed IF frequency has been changed from that used for user cal.
  - Fixed LO changed  
The fixed LO frequency has been changed from that used for user cal.
  - Sideband changed  
The sideband has been changed from that used for user cal.
- 660                    YTF align error
- The alignment failed because of one of the following reasons:
- Peak / floor too small  
During a YTF alignment the level of a peak above the noise floor was too small. If this error occurs then the quality of the YTF alignment is questionable.
  - Image / floor too small  
During a YTF alignment the level of an image response above the noise floor was too small. If this error occurs then the quality of the YTF alignment is questionable.



**-299 to -200:  
Execution Errors**

- 222            Data out of range  
A parameter of a command or query was outside the defined range for that command or query.
- 224            Illegal parameter value  
An unexpected value was entered. (for example, a value other than the available options)
- 225            Out of memory  
The analyzer has insufficient memory to perform the requested operation.
- 221            Settings conflict  
A legal program data element was parsed but could not be executed due to the current device state.
- 223            Too much data  
A block, expression or string parameter of a command or query contained more data than the analyzer could handle due to memory constraints.
- 213            Init ignored  
Indicates that a request for a measurement initiation was ignored as another measurement was in progress.

---

**NOTE**

The front panel **Restart** key does not generate this error, only the remote command `INIT: IMM.`

---

- 230            Data corrupt or stale  
Possibly invalid data; new reading started but not completed since last access.

Error Messages  
**Error Messages**

---

---

**4 Assembly Descriptions and Block Diagrams**

## **What You Will Find in This Chapter**

This chapter provides information about the operation of the NFA that is useful when first troubleshooting an NFA failure. Refer to the appropriate overall block diagram at the end of this chapter when reading the assembly descriptions that follow. The block diagrams show the assemblies in the NFA.

The NFA Series Noise Figure Analyzers are microprocessor-controlled swept receivers with frequency ranges from 10.0 MHz to 1.5 GHz, 3.0 GHz, 6.7 GHz, or 26.5 GHz, depending on the model number. This chapter briefly describes the NFA assemblies:

All of the assemblies listed below are connected to the serial digital interface through the motherboard connection. The data and control information and the power supplies, are distributed through these connections. Each of these assemblies has its own individual EEPROM with stored serial numbers and alignment data for the assembly.

- “A8 RF Assembly” on page 4-113 which includes:
  - “A8A1 RF Assembly” on page 4-114.
  - “A8A1A1 Reference/Third Converter” on page 4-115.
  - “A8A1A2 Front End/LO” on page 4-115.

It also controls the following assemblies:

- “A8A5 Input Attenuator” on page 4-116.
- “A8A2 Second Converter” on page 4-116.
- “A7A3 Frequency Extension” on page 4-117.

It also controls the following assemblies:

- “A8A4 LO Amplifier/IF Switch (LOIS)” on page 4-116.
- “A8A6 YIG-Tuned Filter/Mixer (RYTHM)” on page 4-116.
- “A7A5 IF Assembly” on page 4-118.
- “A4 Processor Assembly” on page 4-119.

The assemblies listed below do not have individual EEPROMs.

- “A8FL1 3.1 GHz Low-Pass Filter (LPF)” on page 4-116.
- “A7 Motherboard and Card Cage Assemblies” on page 4-122.
- “A1 Display/Front Panel” on page 4-123.
- “A5 Power Supply Assembly” on page 4-121.
- “Input Connector” on page 4-114.
- “A2 RF Front End” on page 4-117.
- “A3 Microwave Front End” on page 4-117.

## **A8 RF Assembly**

The A8 RF assembly performs the following major functions:

- Converts the input noise energy to the 21.4 MHz IF.
- Generates first, second and third local oscillator (LO) signals for up-conversion and down-conversion.
- Uses a fractional-N phase-locked loop for first LO stability.
- Generates a 10.0 MHz reference signal.
- Generates a 50.0 MHz reference signal to calibrate the A2 Front End.
- Generates an internal 21.4 MHz IF alignment signal.

When tuned to frequencies  $\leq 3.0$  GHz, the RF section up-converts the signal to a 3.9214 GHz first IF, and then down-converts it to a 321.4 MHz second IF, and finally to a 21.4 MHz third IF. When tuned to frequencies  $> 3.0$  GHz, the RF section down-converts the signal directly to the 321.4 MHz second IF and then to the 21.4 MHz third IF.

The RF Section consists of four assembly board, and three microcircuits. Two of the assembly boards (A8A1A1 and A8A1A2) comprise the A8A1 3.0 GHz RF Assembly. Not all microcircuits and board assemblies are used in every model. Refer to Table 4-1.

**Table 4-1 Assemblies Fitted into Models**

Description	N8972A and N8973A	N8974A and N8975A
A8 RF Assembly (includes A8A1A1 and A8A1A2)	X	X
A8A2 Second Converter	X	X
A8A4 LO Amplifier/IF Switch (LOIS)		X
A8A5 Input Attenuator	X	X
A8A6 YIG-Tuned Filter/Mixer (RYTHM)		X
A8FL1 3.1 GHz Low-Pass Filter (LPF)	X	X
A2 RF Front End Assembly	X	X
A3 Microwave Front End Assembly		X
A7A4 Frequency Extension		X

### **Input Connector**

The input connector is mounted to the middle shield of the A8 RF Assembly. This connector can be easily replaced without disassembling the RF section. Refer to Chapter 6 for the removal procedure.

### **A8A1 RF Assembly**

The A8A1 3.0 GHz RF Assembly is comprised of two boards, the A8A1A1 Reference/Third Converter and the A8A1A2 Front End/LO, in the same shield set. The A8J10 input connector and the Amptd Ref Out connector (part of the A8A1W4 50 MHz Ref Signal). Refer to the following descriptions for “A8A1A1 Reference/Third Converter” and “A8A1A2 Front End/LO.”

## **A8A1A1 Reference/Third Converter**

(Part of the A8A1 RF Assembly)

The standard frequency reference is a 10 MHz VCXO. Option 1D5 adds on oven-controlled crystal oscillator (OCXO). The frequency reference is used to phase-lock a 100 MHz VCXO. This 100 MHz signal is divided by two to yield the 50 MHz amplitude reference signal, and is tripled to provide the 300 MHz third LO.

The 300 MHz third LO is then doubled to yield a 600 MHz signal which is the reference for the first LO and will be used by the A8A2 Second Converter to generate the 3.6 GHz second LO.

The second IF amplifiers provide approximately 24 dB of gain. There is also a 400 MHz low-pass filter and a 321.4 MHz bandpass filter before the third mixer. The third mixer is an active mixer, which includes an IF amplifier. The third mixer down-converts from 321.4 MHz to 21.4 MHz. A variable gain stage, controlled by a DAC, follows the third mixer. The gain is set to provide  $-10$  dBm output at A8A1A1P5 when a  $-10$  dBm signal is applied to the NFA input with 0 dB input attenuation.

The third IF amplifier is followed by a switch to allow the 21.4 MHz alignment signal from A8A1A2 to be routed to the A3 IF Assembly for performing automatic IF alignments between sweeps. Either the output of the third amplifier or the 21.4 MHz alignment signal is routed to the A3 IF Assembly.

A8A1A1 also provides power and control signals for the A8A5 Input Attenuator and the A8A2 Second Converter.

## **A8A1A2 Front End/LO**

(Part of the A8A1 Assembly)

A limiter at the A8A1A2 input protects the first mixer from excessive RF signals. A switch following the limiter allows the 50 MHz amplitude reference signal to be switched-in to perform automatic RF alignments. The first mixer is an active mixer with LO and IF amplifiers. A 700 MHz wide bandpass filter follows the first mixer. The variable gain first IF amplifier corrects for conversion losses in the front end.

The first LO uses a YIG-tuned oscillator in a fractional-N phase-locked loop (PLL). The 600 MHz reference from A8A1A1 is divided by 128 or 129 dual-modulus prescaler and the resulting  $\sim 4.66$  MHz signal is used as the reference for the fractional-N PLL. The 21.4 MHz alignment signal is generated by dividing the first LO signal by 64 and then limiting the divided signal. The first LO signal drives a series of three directional couplers. The first directional coupler is used to drive an ALC loop to level the first LO signal. The second directional coupler provides feedback for the fractional-N PLL. The last directional coupler provides an auxiliary first LO output for driving the A8A4 LO Amplifier/IF Switch (LOIS), which then provides a first LO signal for the A8A6 YIG-Tuned Filter/Mixer (RYTHM).

## **A8 RF Assembly**

### **A8A2 Second Converter**

The A8A2 Second Converter down-converts the 3.9214 GHz first IF to a 321.4 MHz second IF. In high band, it passes the 321.4 MHz first IF from the A8A4 to the A8A1A1 Reference/Third Converter. The converter generates a 3.6 GHz second LO by multiplying a 600 MHz reference. Bandpass filters remove unwanted harmonics of the 600 MHz driving signal. First IF and second LO signals are filtered by cavity filters, which are not user-adjustable.

### **A8A4 LO Amplifier/IF Switch (LOIS)**

The A8A4 Amplifier/IF Switch (LOIS) amplifies the auxiliary LO output from A8A1A2 and levels the output, as necessary, to provide the optimum first LO amplitudes to the A8A6 YIG-Tuned Filter/Mixer (RYTHM).

The IF switch routes the 321.4 MHz IF signal from A8A6 and amplifies it before passing it along to the A8A2 Second Converter. The IF switch also allows for an external 321.4 MHz IF input. A dc bias can be applied to the external IF input signal and is not used in the NFA's configuration of the A8A4 Amplifier/IF Switch (LOIS)

The A8A4 LO Amplifier/IF Switch is controlled by the A7A4 Frequency Extension assembly.

### **A8A5 Input Attenuator**

The input attenuator provides 0 to 45 dB of attenuation in 5 dB steps. Pressing **Preset** selects 0 dB attenuation.

### **A8A6 YIG-Tuned Filter/Mixer (RYTHM)**

The A8A6 RYTHM (Routing YIG-Tuned Harmonic Mixer) is a microcircuit which combines an RF switch, a tracking preselector, and a high-band mixer. The PIN diode switch directs the RF input to the appropriate mixer in the A8A6 or the A8A1 RF assembly.

The tracking preselector is a YIG-tuned filter. It functions as a tunable bandpass filter for high-band signals (2.85 GHz to either 6.5, or 26.5 GHz). The preselector's tuned frequency is controlled by DACs on the A7A4 Frequency Extension assembly.

The high-band mixer is ac coupled. It uses the first, second, and fourth harmonics of the first LO to mix with the incoming signals to cover the frequency range.

### **A8FL1 3.1 GHz Low-Pass Filter (LPF)**

The A8FL1 3.1 GHz LPF precedes the 3.0 GHz RF assembly to eliminate image and out-of-band responses when in low-band. When in low-band, only signals greater than 3.1 GHz can generate image and out-of-band responses. By filtering out these signals, image and out-of-band responses are virtually eliminated.



## **A2 RF Front End**

The A2 Front End Assembly is designed to operate in the 10.0 MHz to 3.0 GHz bandwidth region. It provides protection from transients, it use low noise amplifiers and step attenuators to maintain linearity and provide the required dynamic range. The power detector is used to control the attenuators.

## **A3 Microwave Front End**

The A3 Microwave Front End Assembly is designed to operate in the 3.0 GHz to 26.5 GHz bandwidth region. It provides protection from transients, it use low noise amplifiers and step attenuators to maintain linearity and provide the required dynamic range. The power detector is used to control the attenuators. It contains a 3.0 GHz mechanical switch to control the broadband input noise energy applied which crosses over the 3.0 GHz point.

## **A7A3 Frequency Extension**

The A7A3 Frequency Extension provides power and control signals to the A8A4 LO Amplifier/IF Switch (LOIS) and the A8A6 YIG-Tuned Filter/Mixer (RYTHM). A DAC on A7A4 is used to control the amplitude of LO outputs on the A8A4. A variable-rate generator and sweep clock drive DACs, which control the tuning of the preselector and the A8A6. Several drivers are provided to control the PIN diode switches on A8A4 and A8A6. A DAC also provides bias to the high-band mixer in A8A6.

The flatness correction data for high-band is stored on A7A3.

## **A7A5 IF Assembly**

The A7A5 IF assembly is a selective 4.0 MHz wide Power Meter centered around a 21.4 MHz input signal.

The IF assembly provides the following main functions:

- 4.0 MHz Bandwidth Measurements
- IF Gain Control
- Routing for Narrow Bandwidth Measurements

### **IF Gain Control**

The IF Gain Control is provided by a string of amplifiers, filters, and attenuators. There are two strings, the first string processes the 21.4 MHz. This processed output is downconverted to 6.25 MHz. The 6.25 MHz is processed by the second string. The range of attenuation control is from 0 dB to 70 dB (in 1 dB steps).

### **4.0 MHz Bandwidth Measurements**

The processed 6.25 MHz output is digitally converted and further processed in the PLD to measure the true RMS power.

### **Narrow Bandwidth Measurements**

The narrow bandwidth measurements (100 kHz to 2.0 MHz) are implemented digitally using digital signal processing performed by the A7A4 assembly.

### **IF Detector Linearity**

The IF Assembly contains an EEPROM which holds unique detector linearity calibration data. This data sets the detector to 0dB over its 22dB range. Each IF Assembly is characterized during the manufacturing process. The relevant calibration data is then stored.

---

**NOTE**

The Calibration data is only unique to the IF card. Therefore, any characterized IF Assembly can be fitted to any NFA. The IF Assembly is a modular replacement therefore there is no re-programming required.

---

## **A4 Processor Assembly**

The A4 processor assembly provides the following main functions:

- Main CPU processing
- Memory, including boot memory and firmware
- Video filtering
- Peak detection
- Analog-to-digital conversion of the video output
- Real-time clock
- IF counters
- Communicates with I/O assemblies
- Front panel interface
- LCD interface

### **NFA Battery Information**

The NFA use a 3 V lithium battery to enable the internal memory to retain data. The date that the battery was installed is displayed on a label on the rear panel of the NFA. See Figure 4-1.

The minimum life expectancy of the battery is seven years at 25 °C. If you experience problems with the battery, or the recommended time period for battery replacement has elapsed see, “Contacting Agilent Technologies, Inc.” on page 5-140.

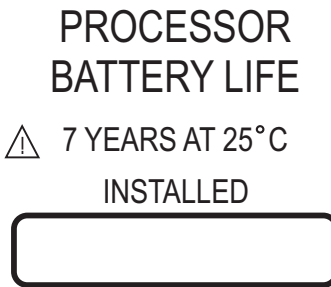
If you wish to replace the battery yourself, refer to the “A4BT1 Battery” on page -184 replacement procedure in Chapter 6. The battery is mounted onto the A4 Processor Assembly. If the battery fails or the battery connection is broken, the real-time clock stops and all data stored in RAM is lost. This data needs to be restored after the battery is replaced. The following are examples of the data types that needs to be restored:

- GPIB address or RS-232 baud rate.
- Current correction factors (factory correction factors are stored on each assembly)
- Any saved states, for example, ENR tables, States, Traces, Limits, Frequency Lists, and Loss Tables.
- Any customized instrument settings, for example, display contrast.

After replacing the battery, write the date of battery replacement on the rear panel label.

**Figure 4-1**

**Rear Panel Battery Information Label**



**Interconnections to Other Assemblies**

There are four connectors to the rear panel:

- |      |   |
|------|---|
| A4J7 | VGA OUTPUT - drives an external VGA-compatible monitor with a signal that has 31.5 kHz horizontal, 60 Hz vertical synchronizing rate, non-interlaced. |
| A4J1 | (service connector for factory use only)  |
| A4J8 | GATE TRIG/EXT TRIG IN (TTL) - not currently supported.  |
| A4J9 | GATE/HI SWP OUT (TTL) - not currently supported.  |

The A4J6 front panel interface connector contains the signals and voltages for all front panel circuitry:

- Power supplies.
- Rotary pulse generator (RPG) interface.
- Front panel keyboard interface.
- AT keyboard interface. An AT-style PC keyboard can be plugged into the front panel. This feature is currently not implemented.
- LCD digital interface. The display controller for the processor assembly can drive an LCD (internal) and a VGA (external) CRT simultaneously.
- Front panel serial interface. This is used to communicate with the front panel of the instrument.
- Probe power (unfiltered supply). The  $-15$  V supply is converted to  $-12.6$  V on the front panel interface board for the probe power connector.

**A4A1 Flash SIMM**

The A4A1 Flash SIMM provides memory for firmware storage.

**A4A2 DRAM SIMM**

The A4A2 DRAM SIMM provides additional memory for storing states, for example, ENR tables, States, Traces, Limits, Frequency Lists, and Loss Tables.

## **A5 Power Supply Assembly**

The A5 Power Supply Assembly can be powered by a 90 to 140 volt or 200 to 264 volt ac supply. It supplies the instrument with all of the supply voltages listed below. The line module, line fuse, and the dc power connector and dc fuse are all part of the power supply assembly. Refer to the parts list in Chapter 5 for the fuse types.

---

**NOTE**

---

The A5 Power Supply Assembly can be powered by an external 12 to 22 Vdc supply, This feature is not available when used in an NFA.

If the instrument loses power for more than 30 seconds, the controller may not retain the power-on state (On or Off) selected by the operator. When power is restored, the instrument will normally be Off. To set the instrument to automatically turn On when power is applied, set the switch at the rear of the instrument. This feature is especially useful under the following conditions:

- If the instrument is in a rack with other instruments, the entire rack can be turned on with a single switch.
- If the instrument is operating unattended, you may want to have measurements continue after power is restored.

The fan is mounted directly to the power supply assembly. The fan speed varies with internal instrument temperature; as the internal temperature increases, the fan speed also increases.

---

**NOTE**

---

Because of safety concerns, the power supply is not repairable.

### **Interconnections to Other Assemblies**

The following power supply connections can be made to other assemblies:

- +5 V, +15 V, +28 V, -5 V, and -15 V supplies to the power supply bus
- Voltage for the fan control
- Connector at the rear panel for a dc supply input.

## **A7 Motherboard and Card Cage Assemblies**

The A7 motherboard provides the power supply and digital bus interconnections between assemblies in the NFA.

### **A7A1 GPIB Assembly**

This A7A1 assembly allows you to control the NFA from a computer that has a General Purpose Interface Bus (GPIB). The GPIB assembly contains an IEEE-488 bus connector. The assembly also includes a 25-pin parallel interface connector for connection with an IEEE 1284 cable to PCL3 or PCL5 compatible printers.

### **A7A2 SIB Assembly**

The A7A2 SIB Assembly controls the following four functions:

1. The RS-232 interface.

This allows you to control your NFA from a computer using that type of interface. It has an RS-232 9-pin connector (Agilent 5182-4794).

2. The LO GPIB interface.

This allows the dedicated control of an external LO by the NFA.

3. The +28V Noise Source Supply (pulsed).

This is supplied from this board to the BNC connector on the front panel. The cable supplying the +28V to the noise source is two sections, hence there is a connecting section in the card cage frame.

4. The SNS Connector interface.

This supplies the interface and associated hardware to control the SNS.

### **A7A4 DSP Assembly**

The A7A4 Digital Sample Processing (DSP) Assembly is used only on models, N8973A, N8974A, and N8975A when making the narrow bandwidth measurements of: 2.0 MHz, 1.0 MHz, 400.0 KHz, 200.0 KHz, and 100.0 KHz.

---

**NOTE**

The 4.0 MHz bandwidth is measured with the A7A5 IF Assembly.

## **Miscellaneous**

### **A1 Display/Front Panel**

#### **Display**

The display is an LCD color flat screen with 640 × 480 VGA resolution. A connector for an external VGA display is available at the rear panel.

#### **A1A1 Front Panel Interface Board**

The A1A1 front panel interface board provides the interface between the display generation circuitry on the processor assembly and the display. It also interfaces the front panel keyboard to the processor assembly. Any display-specific voltages (other than 5 V digital) are created on this board. The front panel interface board also includes the following:

- Main RPG
- Volume RPG
- Plug for external AT style PC keyboard
- Probe power (−12.6 Vdc, +15 Vdc, and ground)
- Circuits to digitally adjust the display

#### **A1A4 Backlight Supply**

The A1A4 backlight supply provides the high voltage to supply the two backlights in the LCD display.

### **A6 Floppy Drive Assembly**

The A6 Floppy (A:) drive allows you to copy data to and from the NFA's internal (C:) drive.

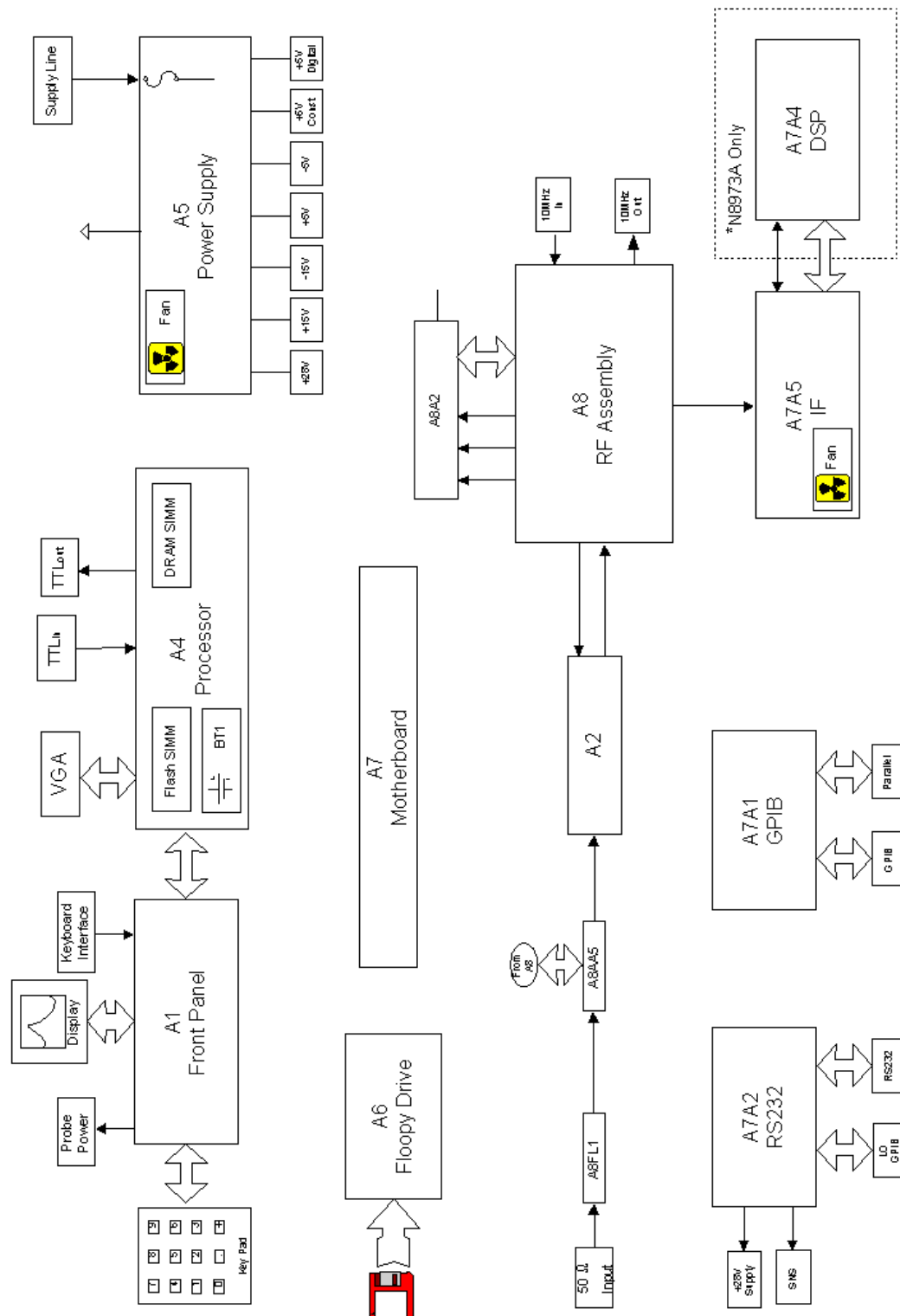
## Block Diagrams

Graphic Symbols Used On Block Diagrams			
	Bus Line		Op Amplifier
	Band Pass Filter		Summer
	High Pass Filter		Phase Frequency Detector
	Low Pass Filter		Mixer
	Band Reject Filter		Oscillator or Generator
	Common Return		Capacitor
	Heavy line indicates path and direction of main signal		Resistor
	Color code for cable		Variable Resistor
	Variable Gain Amplifier		Switch Open
	Amplifier Buffer		Diode
	Inverter Buffer		Slide, Toggle, or Rocker, Switch
	Limiter		Grounded Coaxial Shielding
	Variable Integrator		Analog Digital Converter
	Digital Analog Converter		Directional Coupler
	Numbered Test Point. Measurement aid provided.		
	Lettered Test Point. No Measurement aid provided.		

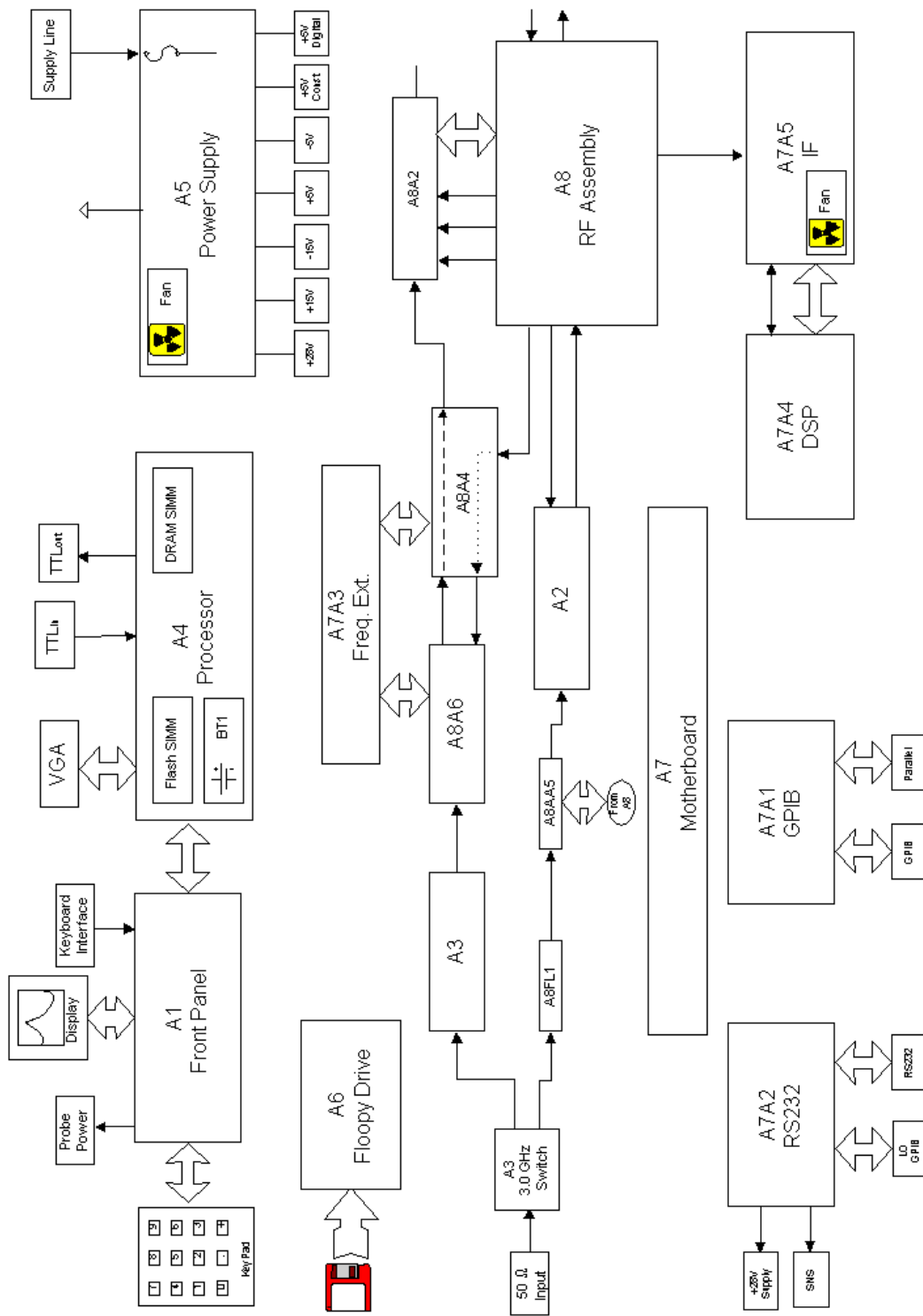
formt123



**Figure 4-2 N8972A and N8973A Block Diagram**



**Figure 4-3 N8974A and N8975A Block Diagram**



**Figure 4-4 A7A5 IF Assembly Block Diagram**

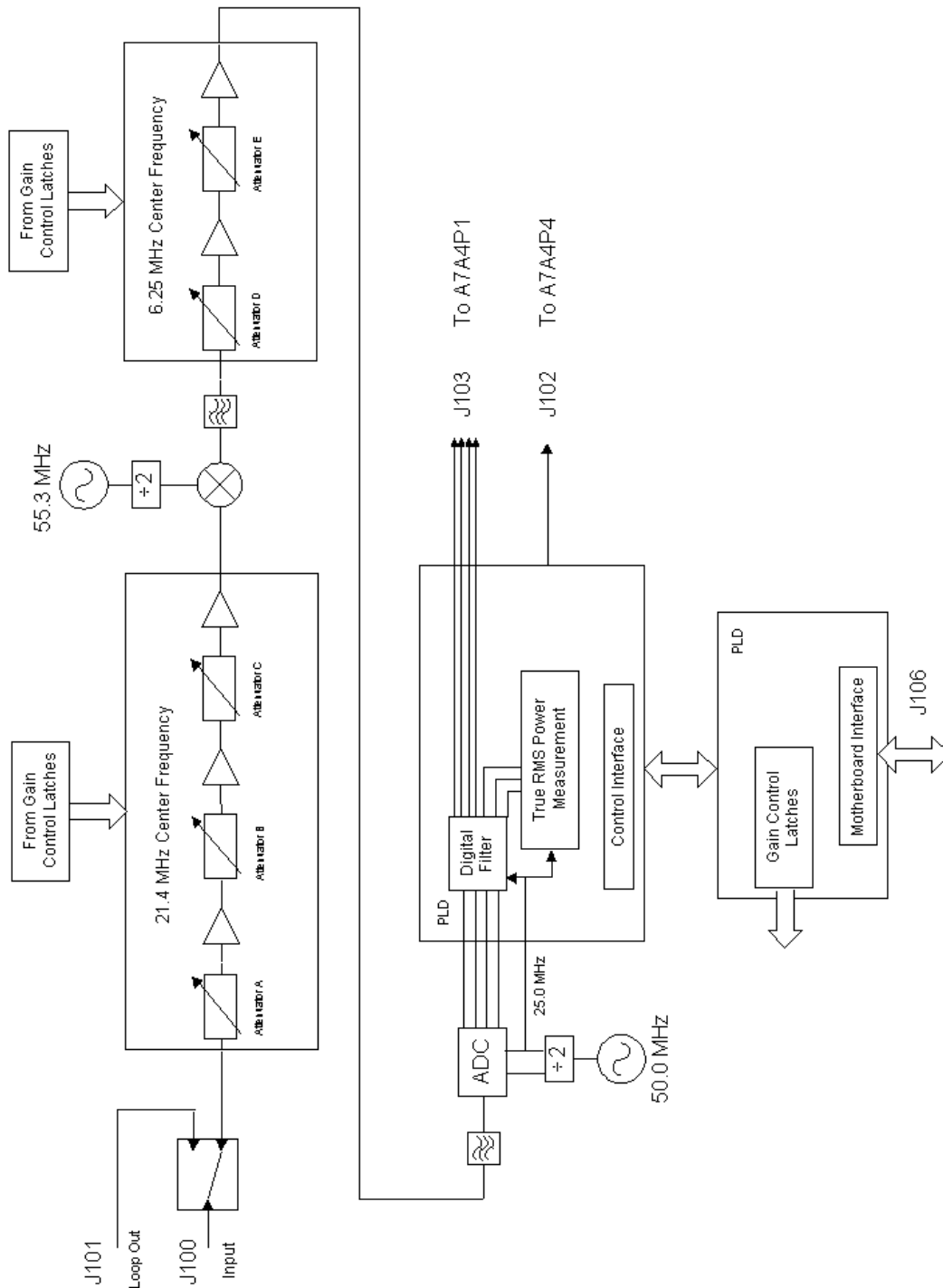


Figure 4-5

**RF Models Cable References and Connectors**

**N8972A and N8973A Cable References and Connections**

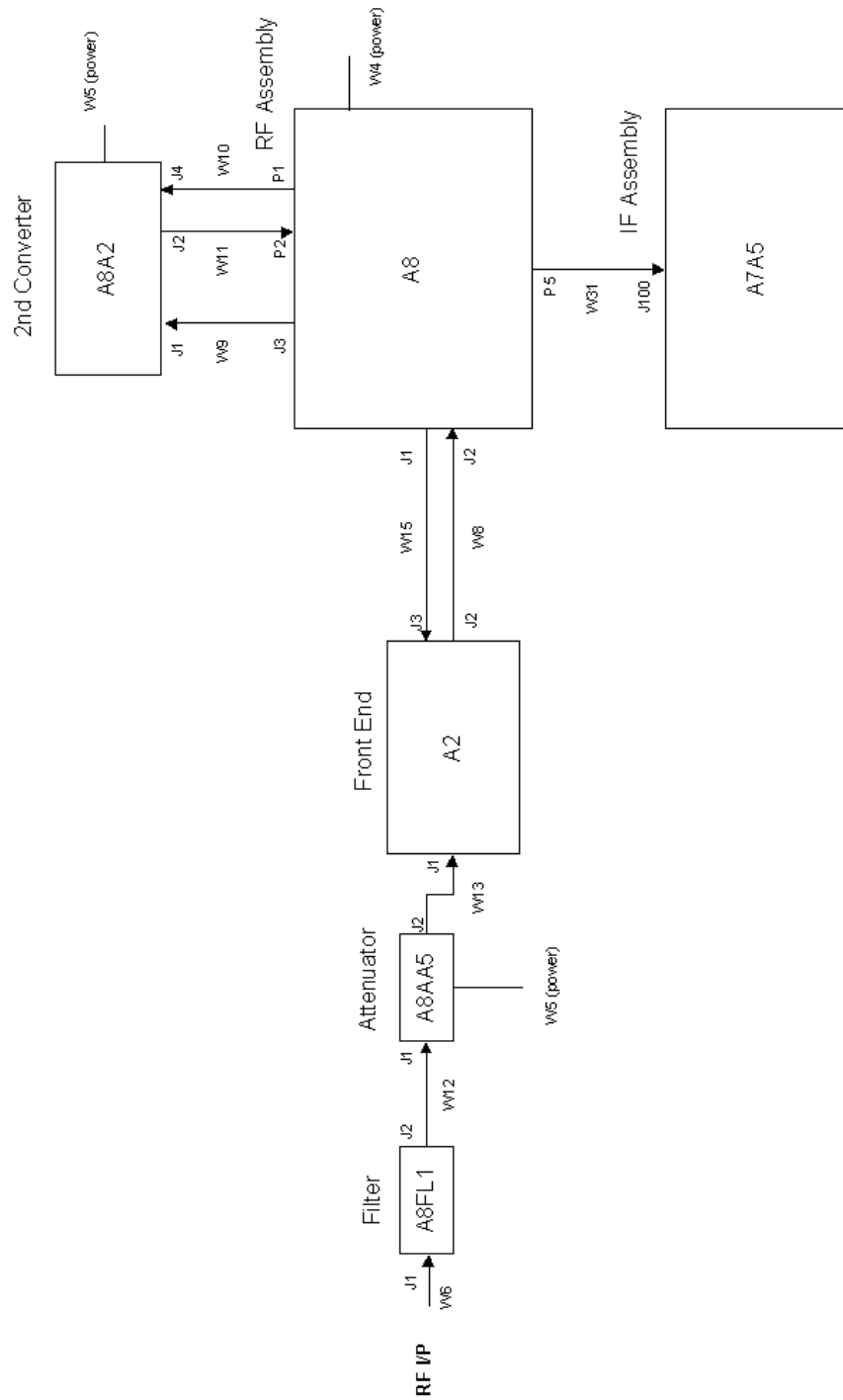
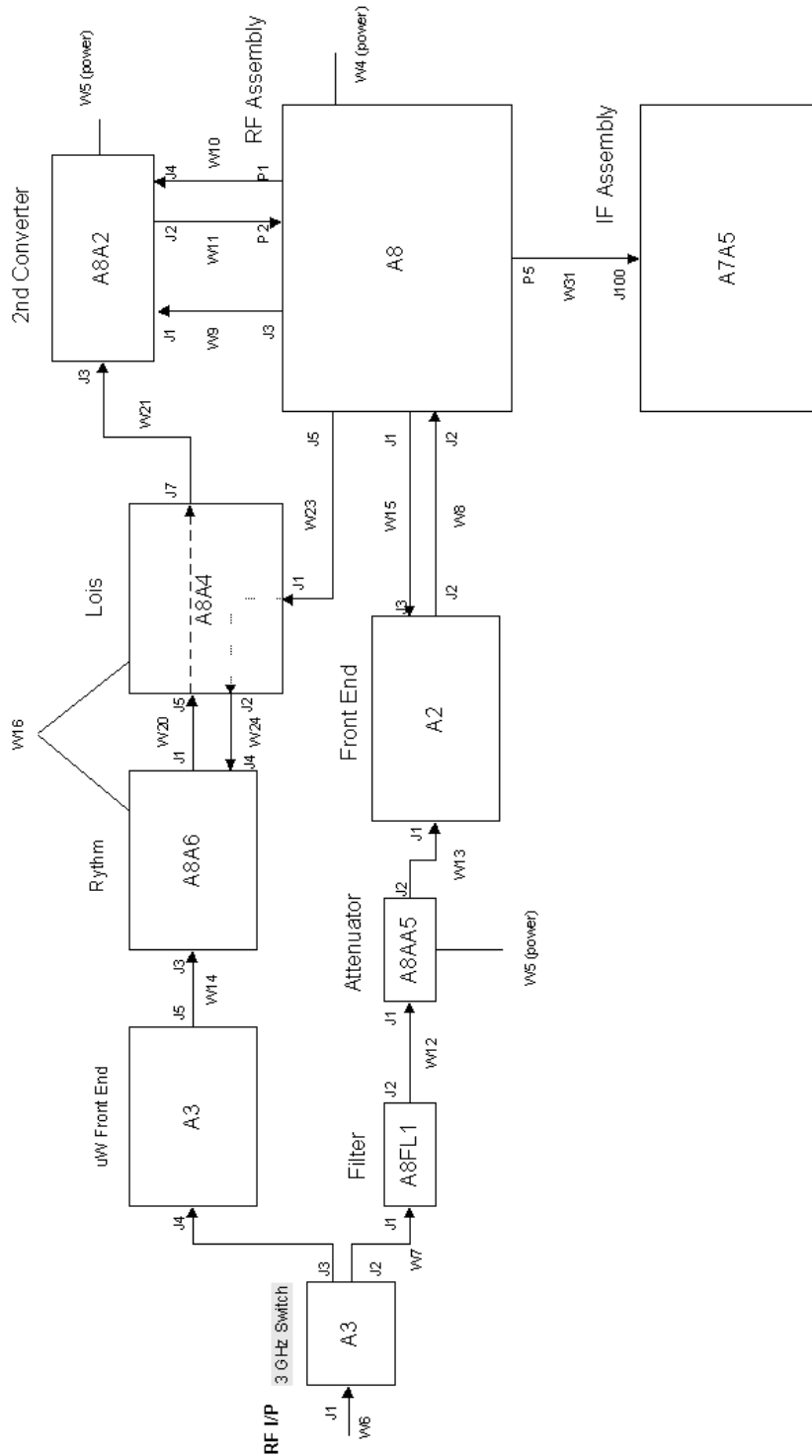


Figure 4-6

Microwave Models Cable References and Connectors

**N8974A and N8975A Cable References and Connections**



Assembly Descriptions and Block Diagrams  
**Block Diagrams**

---

---

**5**      **Parts List**

## **What You Will Find in This Chapter**

This chapter contains information for identifying and ordering replacement assemblies.

Major assembly location information is provided in Chapter 6.

Component level information containing material lists, schematics, and component location diagrams, is available separately.

The following tables are included in this chapter:

- Table 5-1 lists reference designator descriptions.
- Table 5-2 lists value multipliers.
- Table 5-3 lists replacement parts.



## How to Order Parts

To order an assembly or mechanical part listed in this chapter, quote the Agilent Technologies, Inc. part number and indicate the quantity required.

To order a part that is *not* listed, include the following information with the order:

- o Analyzer model number.
- o Analyzer serial number.
- o Description of where the part is located, what it looks like, and its function (if known).
- o Quantity needed

Parts can be ordered by addressing the order to the nearest Agilent Technologies, Inc. office. Customers within the USA can also use either the direct mail-order system, or the direct phone-order system described below. The direct phone-order system has a toll-free phone number available.

### Direct Mail-Order System

Within the USA, Agilent Technologies, Inc. can supply parts through a direct mail-order system. Advantages of using the system are as follows:

- o Direct ordering and shipment from Agilent Technologies, Inc.
- o No maximum or minimum on any mail order. (There is a minimum order amount for parts ordered through a local Agilent Technologies, Inc. office when the orders require billing and invoicing.)
- o Prepaid transportation. (There is a small handling charge for each order.)
- o No invoices.

To provide these advantages, a check or money order must accompany each order. Mail-order forms and specific ordering information are available through your local Agilent Technologies, Inc. office.

Parts List  
**How to Order Parts**

**Direct Phone-Order System**

Within the USA, a phone order system is available for regular and hotline replacement parts service. A toll-free phone number is available, and Mastercard and Visa are accepted. Outside the USA, get in touch with your local sales and service office. For a list of sales and service office locations refer to Table 5-4 on page 140.

**Regular and Hotline Orders**

The toll-free phone number (800) 227-8164 is available Monday through Friday, 6 a.m. to 5 p.m. (Pacific time). Regular orders have a four-day delivery time. For after hours, use the fax number (800) 329-4470.

**Table 5-1 Reference Designations**

REFERENCE DESIGNATIONS					
A	Assembly	E	Miscellaneous Electrical Part	P	Electrical Connector (Movable Portion), Plug
B	Fan, Motor	F	Fuse	R	Resistor
BT	Battery	FL	Filter	S	Switch
C	Capacitor	J	Electrical Connector (Stationary Portion), Jack	W	Cable, Wire, Jumper
DS	Annunciator, Lamp, Light Emitting Diode (LED), Signaling Device (Visible)	K	Relay		
		L	Coil, Inductor		
		MP	Miscellaneous Mechanical Part		

**Table 5-2 Multipliers**

MULTIPLIERS					
Abbreviation	Prefix	Multiple	Abbreviation	Prefix	Multiple
T	tera	$10^{12}$	m	milli	$10^{-3}$
G	giga	$10^9$	$\mu$	micro	$10^{-6}$
M	mega	$10^6$	n	nano	$10^{-9}$
k	kilo	$10^3$	p	pico	$10^{-12}$
da	deka	10	f	femto	$10^{-15}$
d	deci	$10^{-1}$	a	atto	$10^{-18}$
c	centi	$10^{-2}$			

## Replaceable Parts

**Table 5-3** Assembly Level Replaceable Parts

Reference Designator	Description	Agilent Part Number	N8972A	N8973A	N8974A	N8975A
A1	Front Panel Assembly Kit <sup>a</sup>	N8972-61004	X	X		
		N8974-61005			X	X
A1A1	Front Panel Interface Board Assembly	N8972-60005	X	X	X	X
A1A1A1	Rotary Pulse Generator	1990-1865	X	X	X	X
A1A1MP1	Backlight Inverter EMI Shield	E4401-00046	X	X	X	X
A1A1W1	Backlight Inverter Cable	8120-8482	X	X	X	X
A1A2	LCD Assembly Kit	E4401-60180	X	X	X	X
A1A2DS1	Display Backlight, Upper	2090-0577	X	X	X	X
A1A2DS2	Display Backlight, Lower	2090-0577	X	X	X	X
A1A2MP1	LCD Bracket	E4401-00034	X	X	X	X
A1A3MP9	Lens/Keypad Assembly	N8972-61017	X	X	X	X
A1A5	Shock Spreader Assembly	E4403-60032	X	X	X	X
A1MP3	Subpanel Kit	E4401-60104	X	X		
		N8974-61004			X	X
A1MP4	Flex Circuit, Main	E4401-60070	X	X	X	X
A1MP5	Main Keypad	N8972-40002	X	X	X	X
A1MP7	RPG Knob	0370-3229	X	X	X	X
A1MP10	Front Panel Connector Cover	E4401-40006	X	X	X	X
A1MP11	Media Door Assembly Kit	N8972-61012	X	X	X	X
A1MP12	Front Panel Cover	E4401-60193	X	X	X	X
A1MP14	Probe and Keyboard Cover	E4401-40006	X	X	X	X
A1MP16	Model ID Name Plate, 1.5 GHz (N8972A)	N8972-80004	X			
	Model ID Name Plate, 3.0 GHz (N8973A)	N8973-80001		X		
	Model ID Name Plate, 6.7 GHz (N8974A)	N8974-80003			X	
	Model ID Name Plate, 26.5 GHz (N8975A)	N8975-80002				X

Parts List  
**Replaceable Parts**

**Table 5-3 Assembly Level Replaceable Parts**

Reference Designator	Description	Agilent Part Number	N8972A	N8973A	N8974A	N8975A
A1MP17	Front Frame EMI Kit	N8972-61011	X	X	X	X
A1MP18	RF Input Connector Gasket	E4403-20046	X	X	X	X
A1MP20	28V Supply Connector Gasket	E4401-20089	X	X	X	X
A2	Microwave Front End Assembly	N8974-60001			X	X
	Microwave Front End Exchange Assembly	N8974-69001			X	X
A3	Front End Board Assembly	N8972-60001	X	X	X	X
A4	Processor Assembly, Basic	N8974-60009	X	X	X	X
A4A1	4 MB Flash SIMM	E4401-60105	X	X	X	X
A4A2	16 MB DRAM SIMM	1818-6430	X	X	X	X
A4BT1	3 V Lithium Battery	1420-0556	X	X	X	X
A5	Power Supply Assembly	E4401-60186	X	X	X	X
A5B1	Fan	3160-0866	X	X	X	X
A5F1	Fuse (dc) 30 A, 32 V	2110-0809	X	X	X	X
A5F2	Fuse (Line) 5 A, 250 V	2110-0709	X	X	X	X
A5MP1-4	Plastic Rivet	0361-1814	X	X	X	X
A6	Floppy Disc Board Assembly	N8972-60004	X	X	X	X
A7	Motherboard	E4401-60107	X	X	X	X
A7A1	GPIB Board Assembly	E4401-60013	X	X	X	X
A7A2	SIB Board Assembly (LO GPIB)	N8972-60003	X	X	X	X
A7A3	Frequency Extension Assembly	E4404-63001			X	X
A7A4	DSP Board Assembly	N8973-60001		X	X	X
A7A5	IF Board Assembly	N8972-60002	X	X	X	X
	IF Board Exchange Assembly	N8972-69001	X	X	X	X
A7A5MP1	IF Board Fan	E5515-61122	X	X	X	X

**Table 5-3 Assembly Level Replaceable Parts**

Reference Designator	Description	Agilent Part Number	N8972A	N8973A	N8974A	N8975A
A8	N8972/3A RF Assembly	E4403-60037	X	X		
	N8972/3A RF Exchange Assembly	E4403-69037	X	X		
	N8972/3A - 1D5 RF Assembly Precision Frequency Reference	E4403-60038	X	X		
	N8972/3A - 1D5 RF Exchange Assembly Precision Frequency Ref.	E4403-69038	X	X		
	N8974/5A RF Assembly	N8974-60012			X	X
	N8974/5A RF Exchange Assembly	N8974-69012			X	X
	N8974/5A - 1D5 RF Assembly Precision Frequency Reference	N8972-60013			X	X
	N8974/5A - 1D5 RF Exchange Assembly Precision Frequency Ref.	N8972-69013			X	X
A8A2	Second Converter	5086-7958	X	X	X	X
A8A3	DC Block Input Blanking Plate	N8972-61008	X	X	X	X
A8A4	LO Amplifier/IF Switch (LOIS)	E4404-60026			X	X
A8A5	Input Attenuator	33321-60060	X	X	X	X
A8A6	26.5 GHz YIG-Tuned Harmonic Mixer (RYTHM)	5087-7031			X	X
	26.5 GHz YIG-Tuned Harmonic Mixer (RYTHM) Exchange	5087-6031			X	X
A8FL1	3.1 GHz Low Pass Filter (LPF)	0955-1134	X	X	X	X
A8MP1	Micro Bracket	E4404-00001			X	X
A8MP2	Sub Bracket	E4404-00003			X	X
A8MP3	Filter Clamp	5022-3619			X	X
A8MP4	Attenuator Bracket	E4403-00001	X	X	X	X
A8MP5	Filter Bracket	N8972-00003	X	X	X	X
A1A4	Rear Frame Assembly	E4401-20021	X	X	X	X
A8MP24	Type-N Connector Gasket, RF Input	E4403-20046	X	X		
MP1	Chassis Cover, Inner Shield	N8972-61002	X	X	X	X
MP4	Dress Cover	N8974-00007	X	X	X	X
MP5	Handle Assembly	E4401-40001	X	X	X	X
MP6	Chassis	E4401-00045	X	X		
	Microwave Chassis	N8974-61003			X	X

Parts List  
**Replaceable Parts**

**Table 5-3 Assembly Level Replaceable Parts**

Reference Designator	Description	Agilent Part Number	N8972A	N8973A	N8974A	N8975A
MP7	Vibration Support	E4401-40026	X	X	X	X
W1	Cable Assembly, Processor to Front Panel Interface (Ribbon Cable)	8120-6919	X	X	X	X
W3	Cable Assembly, Front Panel Interface to Display (Ribbon Cable)	E4401-60070	X	X	X	X
W4	Cable Assembly, RF Power and Control (Ribbon Cable)	E4403-60018	X	X	X	X
W5	Cable Assembly, Attenuator and 2nd Converter Power and Control (Ribbon Cable)	E4403-60019	X	X		
	Cable Assembly, Attenuator and 2nd Converter Power and Control (Ribbon Cable)	N8974-60014			X	X
W6	Cable Assembly, I/P to A8FL1J1 (Semi-rigid Coaxial)	N8972-21001	X	X		
	Cable Assembly, I/P to A3J1 (Semi-rigid Coaxial)	N8974-21007			X	X
W7	Cable Assembly, A3J2 to A8FL1J1 (Semi-rigid Coaxial)	N8974-21010			X	X
W8	Cable Assembly, A8A1A2J2 to A2J2 (Semi-rigid Coaxial)	N8972-21003	X	X		
	Cable Assembly, A8A1A2J2 to A2J2 (Semi-rigid Coaxial)	N8974-21008			X	X
W9	Cable Assembly, A8A1A2J3 to A8A2J1 3.9107 GHz IF (Semi-rigid Coaxial)	E4403-20029	X	X	X	X
W10	Cable Assembly, 600 MHz 2nd LO Drive A8A1A1P1 to A8A2J4 (Flexible Coaxial)	8120-8674	X	X	X	X
W11	Cable Assembly, 2nd Converter 321.4 MHz IF Output A8A2J2 to A8A1A1P2 (Flexible Coaxial)	8120-8674	X	X	X	X
W12	Cable Assembly, A8FL1J2 to A8A5J1 (Semi-rigid Coaxial)	N8972-21002	X	X		
	Cable Assembly, A8FL1J2 to A8A5J1 (Semi-rigid Coaxial)	N8974-21009			X	X

**Table 5-3 Assembly Level Replaceable Parts**

Reference Designator	Description	Agilent Part Number	N8972A	N8973A	N8974A	N8975A
W13	Cable Assembly, A8A5J2 to A2J1 (Semi-rigid Coaxial)	N8972-21006	X	X		
	Cable Assembly, A8A5J2 to A2J1 (Semi-rigid Coaxial)	N8974-21006			X	X
W14	Cable Assembly, A3J5 to A8A6J3 (Semi-rigid Coaxial)	N8974-21005			X	X
W15	Cable Assembly, A8A1A2J4 to A3J3 (Flexible Coaxial)	8120-5105	X	X	X	X
W16	Cable Assembly, RYTHM/LOIS Power and Control	N8974-60011			X	X
W20	Cable Assembly, A8A6J1 to A8A4J5 RYTHM 321.4 MHz IF Output (Flexible Coaxial)	8120-8674			X	X
W21	Cable Assembly, A8A4J7 to A8A2J3 (Flexible Coaxial)	8120-5141			X	X
W23	Cable Assembly, A8A1A2J5 to A8A4J1 Auxiliary LO Output (Semi-rigid Coaxial)	E4404-20008			X	X
W24	Cable Assembly, A8A4J2 to A8A6J4 RYTHM LO (Semi-rigid Coaxial)	E4404-20005			X	X
W25 <sup>b</sup>	Cable Assembly, A7A2J102 to +28V port	8120-5042	X	X		
W26 <sup>b</sup>	Cable Assembly, A7A2J102 to +28V port	8120-5042	X	X		
W28	Cable Assembly, A7A2J102 to front panel +28V port (Flexible Coaxial)	N8974-60015	X <sup>b</sup>	X <sup>b</sup>	X	X
W31	Cable Assembly, 21.4 MHz IF Output A8A1A1P5 to A7A5J100 (Flexible Coaxial)	8120-5024	X	X	X	X
W32	Cable Assembly, A7A4P4 to A7A5J102 (Flexible Coaxial)	8120-8790		X	X	X
W33	Cable Assembly, A7A4S1 to A7A5J103 (Ribbon Cable)	8120-6986		X	X	X

- a. Ensure you order the appropriate Model ID Name Plate (A1MP16)
- b. On earlier versions of the N8972A and N8973A the W28 cable assembly used two parts, W25 and W26, to provide the connection between A7A2J102 and the +28V port.

## Contacting Agilent Technologies, Inc.

Use the information in this section to obtain Agilent Technologies, Inc. sales and service offices information. Sales and service offices are located around the world to provide complete support for your analyzer. To obtain servicing information or to order replacement parts, get in touch with the nearest Agilent Technologies, Inc. Sales and Service office listed in Table 5-4. In any correspondence or telephone conversations, refer to the analyzer by its model number and full serial number. With this information, the Agilent representative can quickly determine whether your unit is still within its warranty period.

If you have a problem with your *Agilent N2717A Performance Verification Software*, get in touch with Agilent Technologies, Inc. for assistance. For software technical support, get in touch with the Agilent Technologies, Inc. Test and Measurement Call Center at 1-800-452-4844.

By internet, phone, or fax, get assistance with all your test and measurement needs.

**Table 5-4 Contacting Agilent**

**On-line assistance:** [www.agilent.com/find/assist](http://www.agilent.com/find/assist)

<b>United States</b> (tel) 1 800 452 4844	<b>Japan</b> (tel) (+81) 426 56 7832 (fax) (+81) 426 56 7840	<b>New Zealand</b> (tel) 0 800 738 378 (fax) (+64) 4 495 8950	<b>Europe</b> (tel) (+31) 20 547 2323 (fax) (+31) 20 547 2390
<b>Canada</b> (tel) 1 877 894 4414 (fax) (905) 282 6495	<b>Latin America</b> (tel) (305) 269 7500 (fax) (305) 269 7599	<b>Australia</b> (tel) 1 800 629 485 (fax) (+61) 3 9210 5947	

**Asia Call Center Numbers**

Country	Phone Number	Fax Number
Singapore	1-800-375-8100	(65) 836-0252
Malaysia	1-800-828-848	1-800-801664
Philippines	(632) 8426802 1-800-16510170 (PLDT Subscriber Only)	(632) 8426809 1-800-16510288 (PLDT Subscriber Only)
Thailand	(088) 226-008 (outside Bangkok) (662) 661-3999 (within Bangkok)	(66) 1-661-3714
Hong Kong	800-930-871	(852) 2506 9233
Taiwan	0800-047-866	(886) 2 25456723
People's Republic of China	800-810-0189 (preferred) 10800-650-0021	10800-650-0121
India	1-600-11-2929	000-800-650-1101



## Instrument Serial Numbers

Agilent Technologies, Inc. makes frequent improvements to its products to enhance performance, usability, or reliability. Agilent Technologies, Inc. service personnel have access to complete records of design changes to each type of instrument, based on the instrument's serial number and option designation.

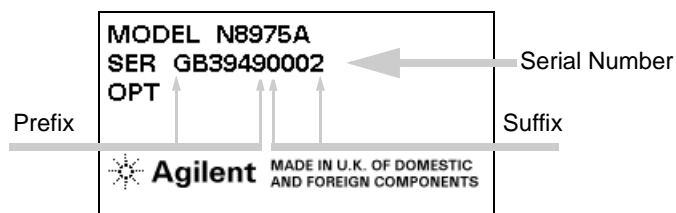
Whenever you contact Agilent Technologies, Inc. about your analyzer, have the complete serial number available. This will ensure that you obtain accurate service information.

A serial number label is attached to the rear of the analyzer. This label has two instrument identification entries: the first provides the instrument's serial number, and the second provides the identification number for each option built into the instrument.

The serial number has two parts: the prefix (two letters and the first four numbers), and the suffix (the last four numbers). Refer to Figure 5-1.

Figure 5-1

### Example Serial Number



The two letters identify the country in which the unit was manufactured. The four numbers of the prefix are a code identifying the date of the last major design change incorporated in your analyzer. The four digit suffix is a sequential number and, coupled with the prefix, provides a unique identification for each unit produced. Whenever you list the serial number or refer to it in obtaining information about your analyzer, be sure to use the complete number, including the full prefix and the suffix.

## How to Return Your Analyzer for Service

### Service Tag

If you are returning your analyzer to Agilent Technologies, Inc. for servicing, fill in and attach a blue service tag. Several service tags are supplied at the rear of this chapter. Please be as specific as possible about the nature of the problem. If you have recorded any error messages that appeared on the display, or have completed a Performance Test Record, or have any other specific data on the performance of your analyzer, please send a copy of this information with your analyzer.

### Original Packaging

Before shipping, pack the unit in the original factory packaging materials if they are available. If the original materials were not retained, see “Other Packaging” on page 5-144.

---

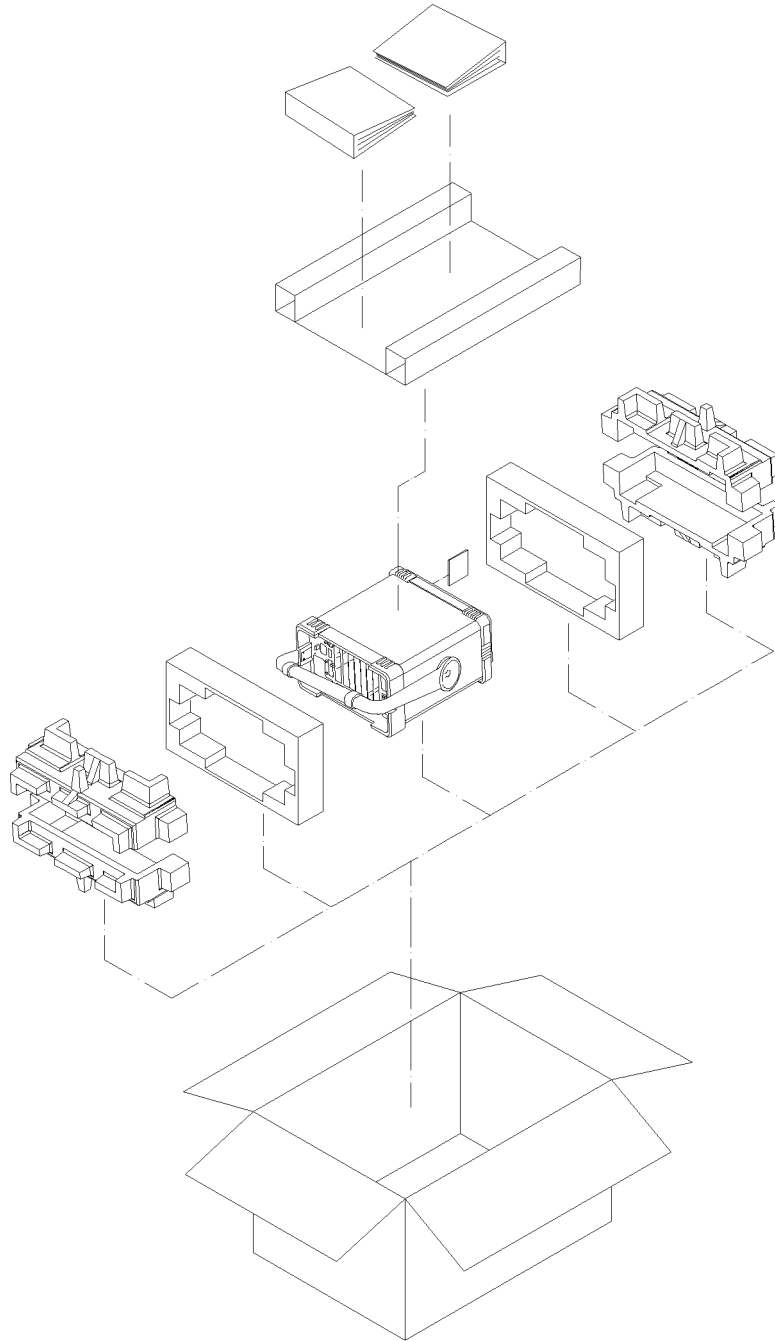
**NOTE** Ensure that the instrument handle is in the rear-facing position in order to reduce the possibility of damage during shipping. Refer to the following illustration.

---

---

**NOTE** Install the transportation disk into the floppy drive to reduce the possibility of damage during shipping. If the original transportation disk is not available, a blank floppy may be substituted.

---



orm122

## **Other Packaging**

---

**CAUTION**

Analyzer damage can result from using packaging materials other than those specified. Never use styrene pellets in any shape as packaging materials. They do not adequately cushion the equipment or prevent it from shifting in the carton. They cause equipment damage by generating static electricity and by lodging in the analyzer louvers, blocking airflow.

---

You can repack the instrument with commercially available materials, as follows:

1. Attach a completed service tag to the instrument.
2. Install the transportation disk or a blank floppy disk into the disk drive.
3. If you have a front-panel cover, install it on the instrument. If you do not have a front panel cover, make sure the instrument handle is in the forward-facing position to protect the control panel.
4. Wrap the instrument in antistatic plastic to reduce the possibility of damage caused by electrostatic discharge.
5. Use a strong shipping container. A double-walled, corrugated cardboard carton with 159 kg (350 lb) bursting strength is adequate. The carton must be both large enough and strong enough to accommodate the analyzer. Allow at least 3 to 4 inches on all sides of the analyzer for packing material.
6. Surround the equipment with three to four inches of packing material to prevent the equipment from moving in the carton. If packing foam is not available, the best alternative is S.D.-240 Air Cap™ from Sealed Air Corporation (Hayward, California, 94545). Air Cap looks like a plastic sheet filled with 1-1/4 inch air bubbles. Use the pink-colored Air Cap to reduce static electricity. Wrapping the equipment several times in this material should both protect the equipment and prevent it from moving in the carton.
7. Seal the shipping container securely with strong nylon adhesive tape.
8. Mark the shipping container “FRAGILE, HANDLE WITH CARE” to assure careful handling.
9. Retain copies of all shipping papers

---

---

**6****Replacing Assemblies**

## **What You Will Find in This Chapter**

The procedures in this chapter describe the location, removal and replacement of assemblies in the noise figure analyzer. Refer to Chapter 5, “Parts List,” for part numbers and ordering information. Refer to Chapter 4, “Assembly Descriptions and Block Diagrams,” for assembly descriptions.

Numbers in parentheses, for example (1), indicate numerical callouts on the figures.

## Before You Start

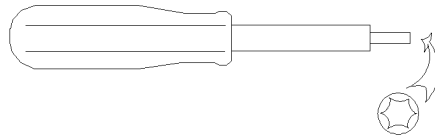
Before starting to disassemble the instrument:

- Check that you are familiar with the safety symbols marked on the instrument, and read the general safety considerations and the safety note definitions given in the front of this guide.
- The noise figure analyzer contains static sensitive components. Read the section entitled “ESD Information” in Chapter 1.

## Service tools you will need

**Figure 6-1**

**TORX Tool**



s1736a

**Table 6-1**

Description	Agilent Part Number
TORX Hand Driver - Size T8	8710-1614
TORX Hand Driver - Size T10	8710-1623
TORX Hand Driver - Size T15	8710-1622

**NOTE**

Refer to Table 2-2 for the correct torque value to be applied to the cable connector.

## After a noise figure analyzer repair

If one or more noise figure analyzer assemblies have been replaced, perform the calibration and performance verification tests. Refer to Chapter 7, “Post-Repair Procedures,” for further information on the calibration and performance verification tests.

## **Removal and Replacement Procedures in This Chapter**

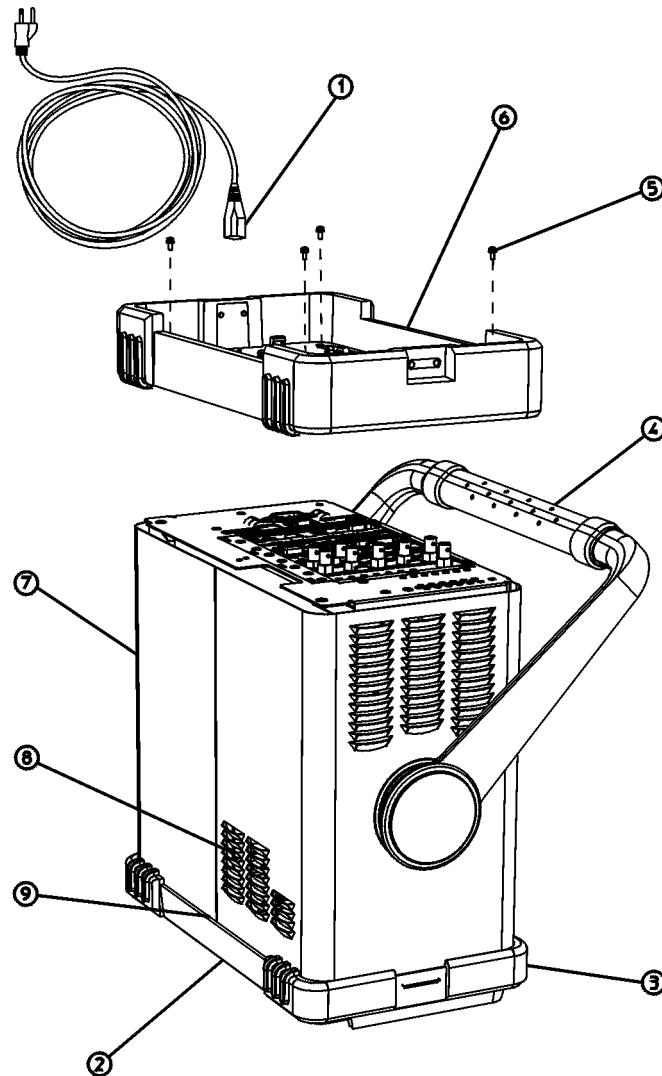
This chapter describes the removal and replacement procedures for the following Agilent NFA series noise figure analyzer assemblies:

- “Instrument Outer Case” on page 149
- “Chassis Cover” on page 153
- “A1 Front Frame Assembly” on page 155
- “A1MP16 Nameplate” on page 159
- “Connector Label” on page 160
- “Front Frame Subassemblies” on page 164, which includes:
  - “A1A2 Display” on page 164
  - “A1A1 Front Panel Interface Board” on page 167
  - “Front Panel RPG” on page 169
  - “Keypad/Flex Circuit” on page 170
  - “A1A3MP9 Lens/Keypad Assembly” on page 171
  - “A1A2DS1/A1A2DS2 Display Backlight” on page 172
  - “A1MP11 Media Door/Bezel” on page 173
- “A3 Microwave Front End Assembly” on page 177
- “A2 RF Front End” on page 179
- “A4 Processor Assembly” on page 181
- “A4A1 and A4A2 Flash and DRAM SIMM” on page 183
- “A4BT1 Battery” on page 184
- “A5 Power Supply” on page 185
- “A5B1 Fan” on page 187
- “A6 Floppy Disc Assembly” on page 189
- “A7 Motherboard Assembly” on page 191
- “Card Cage Assemblies” on page 194, which includes:
  - “GPIB, RS-232, Frequency Extension, DSP, IF” on page 194
- “A8 RF Assembly” on page 197
- “A8 Sub-assemblies” on page 203, which includes:
  - “A8A4 LO Amp/IF Switch Assembly” on page 203
  - “A8A5 Input Attenuator” on page 207
  - “A8A6 YIG-Tuned Filter/Mixer” on page 204
  - “A8A2 Second Converter” on page 209
  - “Input Connector” on page 213



## Instrument Outer Case

Figure 6-2 Outer Case, Rear Frame Removal



sl745b

### Removal

- Step 1.** Referring to Figure 6-2 disconnect the noise figure analyzer from ac power (1).
- Step 2.** Remove any adapters or cables (2) connected to the front frame.
- Step 3.** Carefully place the analyzer on the work surface with the front frame (3) facing down.
- Step 4.** Remove the handle (4) as shown in Figure 6-3.

**Figure 6-3**

**Handle Removal**



**Step 5.** Remove the 6 screws (5), as shown in Figure 6-4, that hold the rear frame and outer case in place.

**Figure 6-4**      **Rear Panel Screw Removal**

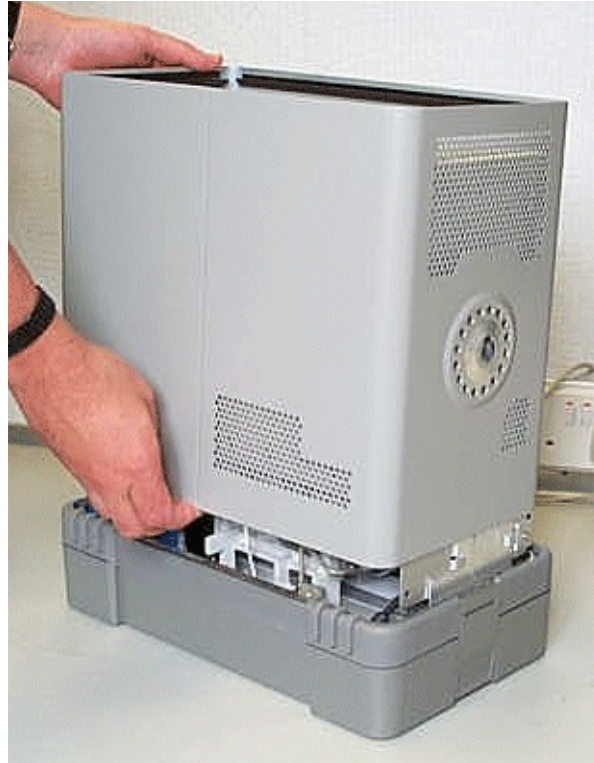


**Step 6.** Remove the rear frame assembly.

**Step 7.** Pull the outer cover off towards the rear of the instrument as shown in Figure 6-5.

Figure 6-5

Outer Cover Removal



**Replacement**

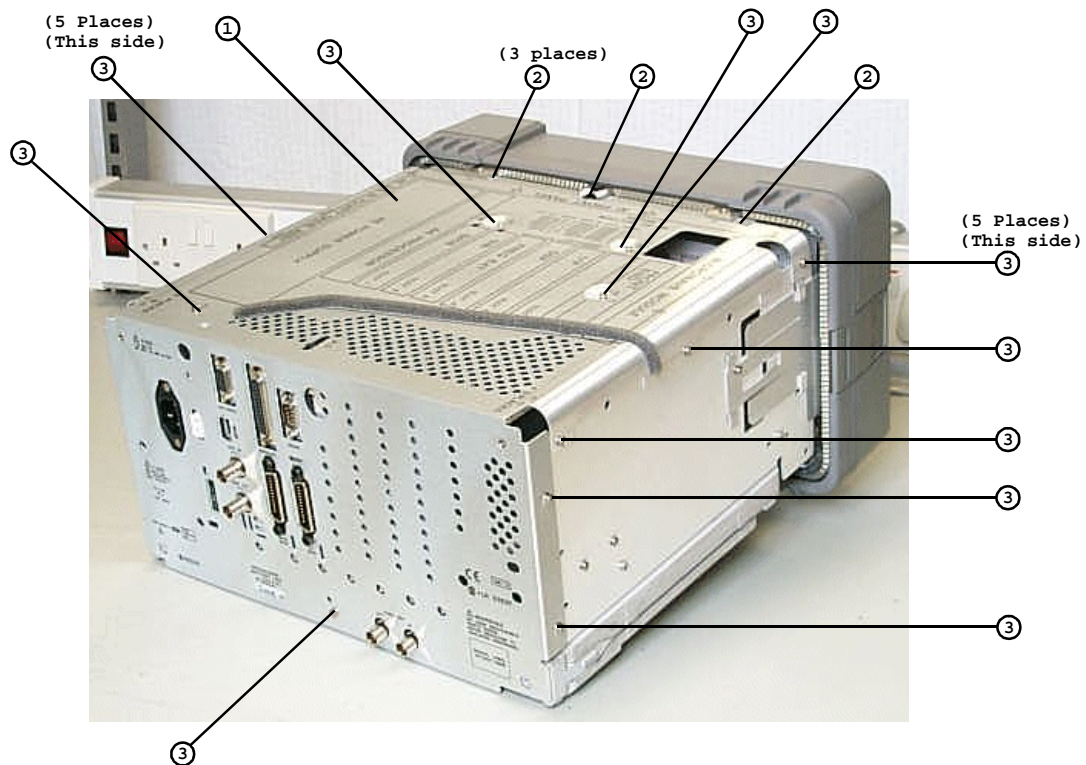
- Step 1.** Referring to Figure 6-2, carefully place the analyzer on the work surface with the front frame (3) facing down.
- Step 2.** Replace the instrument outer case, matching the grill (8) on the bottom of the case to the bottom of the analyzer.
- Step 3.** Fit the leading edge of the case completely into the slot (9) on the back of the front frame assembly.
- Step 4.** Replace the rear frame assembly, using the 6 screws (5) to fasten the rear frame to the instrument. Tighten them to 21 inch-pounds.

## Chassis Cover

### Removal

- Step 1.** If you have not previously done so, remove the instrument outer case. Refer to the removal procedure “Instrument Outer Case” on page 149.
- Step 2.** Lay the instrument flat as shown in Figure 6-6.
- Step 3.** Remove the 18 screws (2) and (3) attaching the chassis cover (1) to the chassis.
- Step 4.** The chassis cover can now be removed from the chassis.

**Figure 6-6** Chassis Cover Screw Removal



**Figure 6-7**      **Chassis Cover Replacement**



### **Replacement**

- Step 1.** Position the chassis cover (1) over the instrument as shown in Figure 6-7, then lower onto the instrument. Ensure all external connectors are not obstructing the cover.
- Step 2.** Replace the 18 screws (2) as (3) shown and tighten them to 9 inch-pounds.
- Step 3.** Replace the outer case. Refer to the replacement procedure “Instrument Outer Case” on page 149.



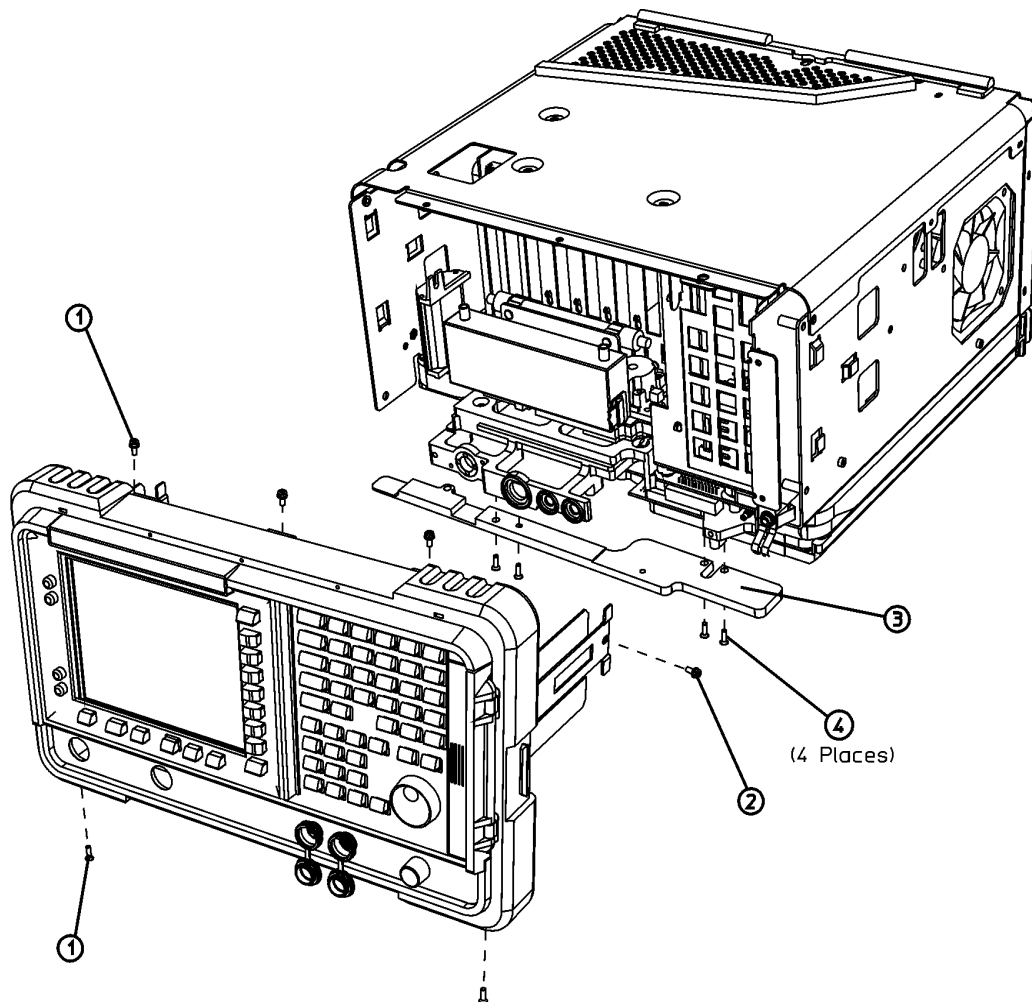
## A1 Front Frame Assembly

**CAUTION** Use ESD precautions when performing this replacement procedure.

### Extension of the Front Frame Assembly

The A1 front frame assembly can be extended from the instrument without detaching any connections.

**Figure 6-8** A1 Front Frame Assembly Removal



sl738b

**Step 1.** Remove the instrument outer case. Refer to the removal procedure “Instrument Outer Case” on page 149.

## Replacing Assemblies

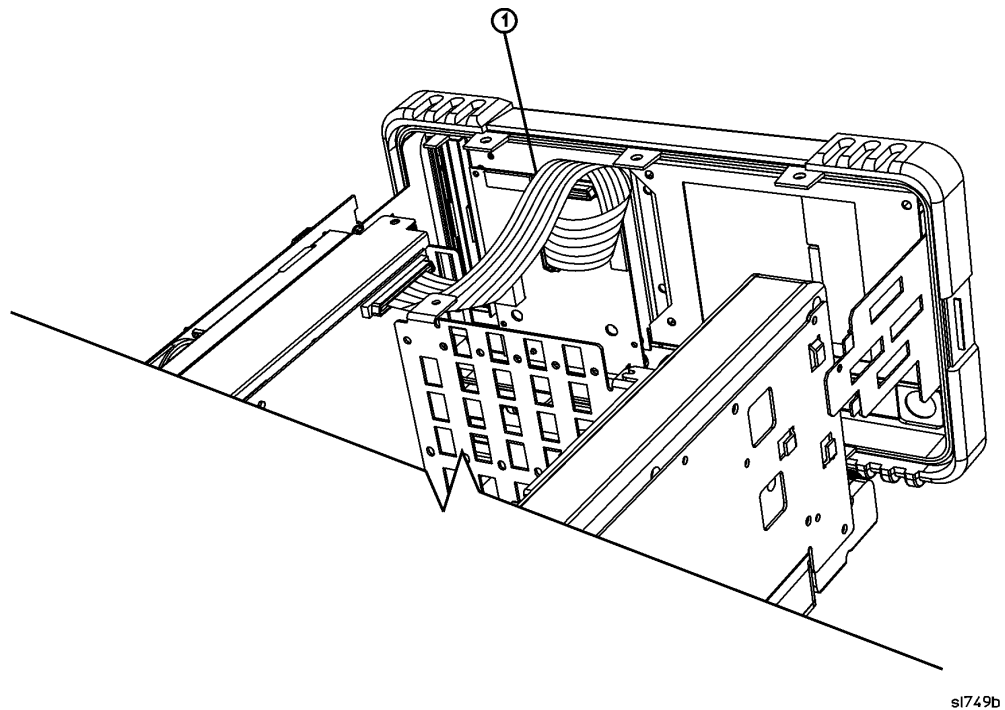
### A1 Front Frame Assembly

- Step 2.** Refer to Figure 6-8. With the instrument still on its face, remove the 5 screws (1), two on the bottom side and three on the top of the instrument. These screws secure the front frame to the RF assembly and chassis cover.
- Step 3.** Place the instrument with the top side facing up and remove the remaining 2 screws (2) that secure the front frame subpanel to the chassis.
- Step 4.** Slide the front frame forward until it catches on the tabs on the sides of the chassis.

### Removal

Refer to Figure 6-8. To completely remove the A1 front frame assembly, complete the “Extension of the Front Frame Assembly” procedure, then continue with the following steps:

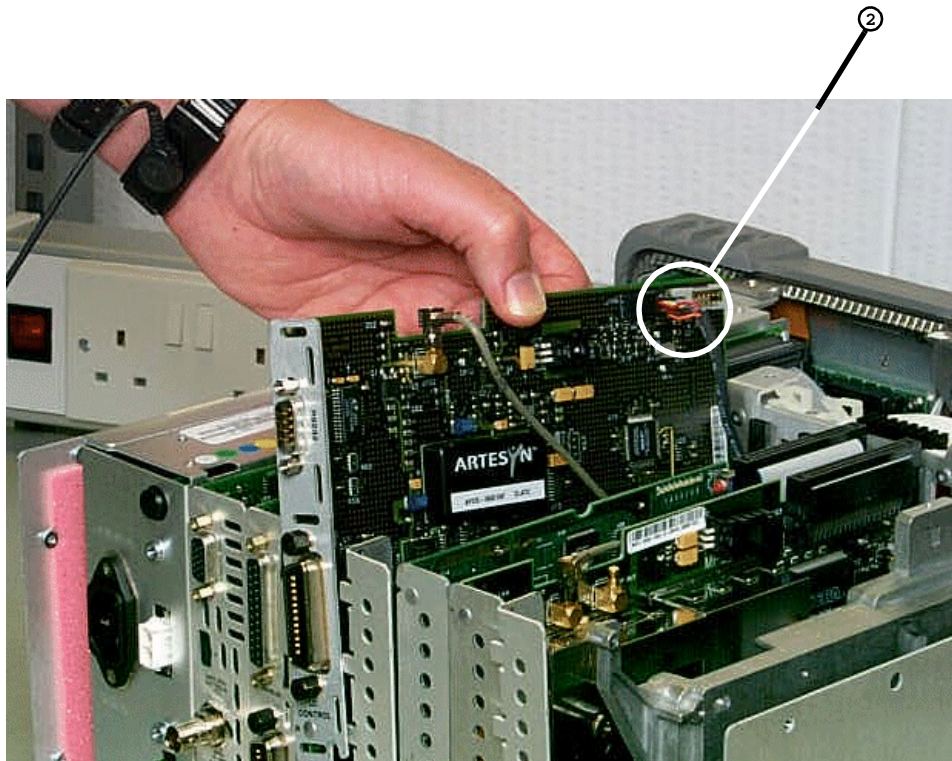
**Figure 6-9** Front Frame Ribbon Cable



- Step 1.** Refer to Figure 6-9. Disconnect the ribbon cable W1 (1) from the A1A1 front panel interface board.
- Step 2.** Refer to Figure 6-10. Disconnect the smart noise source cable (2) from the A7A2 J104 connector.



**Figure 6-10** Smart Noise Source Cable



**Step 3.** Carefully pull the sides of the front frame assembly away from the chassis and over the tabs on the chassis.

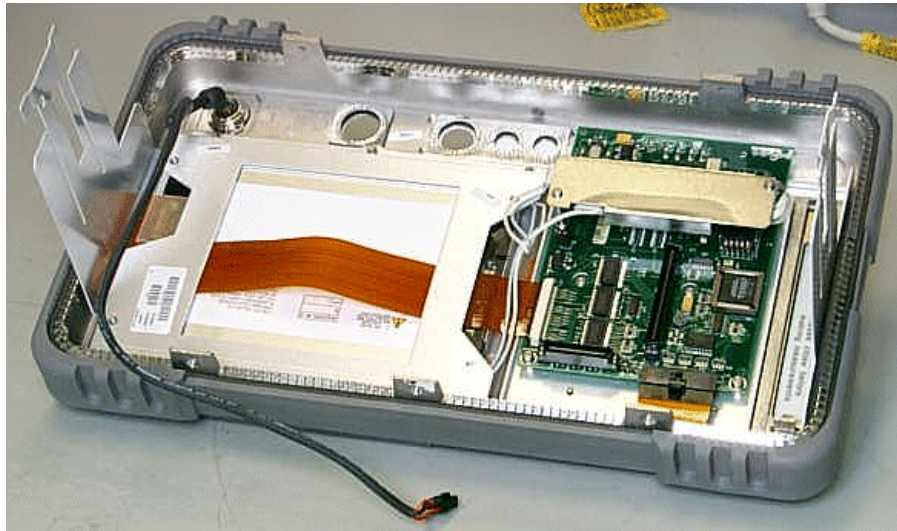
**Step 4.** Slide the front frame forward to disengage from the chassis assembly.

Replacing Assemblies  
**A1 Front Frame Assembly**

**Replacement**

- Step 1.** Align the A1 front frame assembly rails with the chassis as shown in Figure 6-8.
- Step 2.** Refer to Figure 6-10. Connect the smart noise source cable (2) to the J104 connector on the A7A2 assembly.
- Step 3.** Refer to Figure 6-9. Connect the ribbon cable W1 (1) to the front frame assembly.
- Step 4.** Carefully slide the front frame toward the chassis, assuring the ribbon cable is not pinched between assemblies, and the RF input and normal noise source connectors lines up correctly with the openings in the front frame.
- Step 5.** Refer to Figure 6-8. Replace the screws (1) that secure the front frame to the chassis. Tighten them to 9 inch-pounds.
- Step 6.** Replace the outer case. Refer to the replacement procedure for the “Instrument Outer Case” on page 149.
- Step 7.** Refer to Chapter 7, “Post-Repair Procedures,” for further information on the calibration and performance verification tests required.

**Figure 6-11**      **Front Panel Assembly**



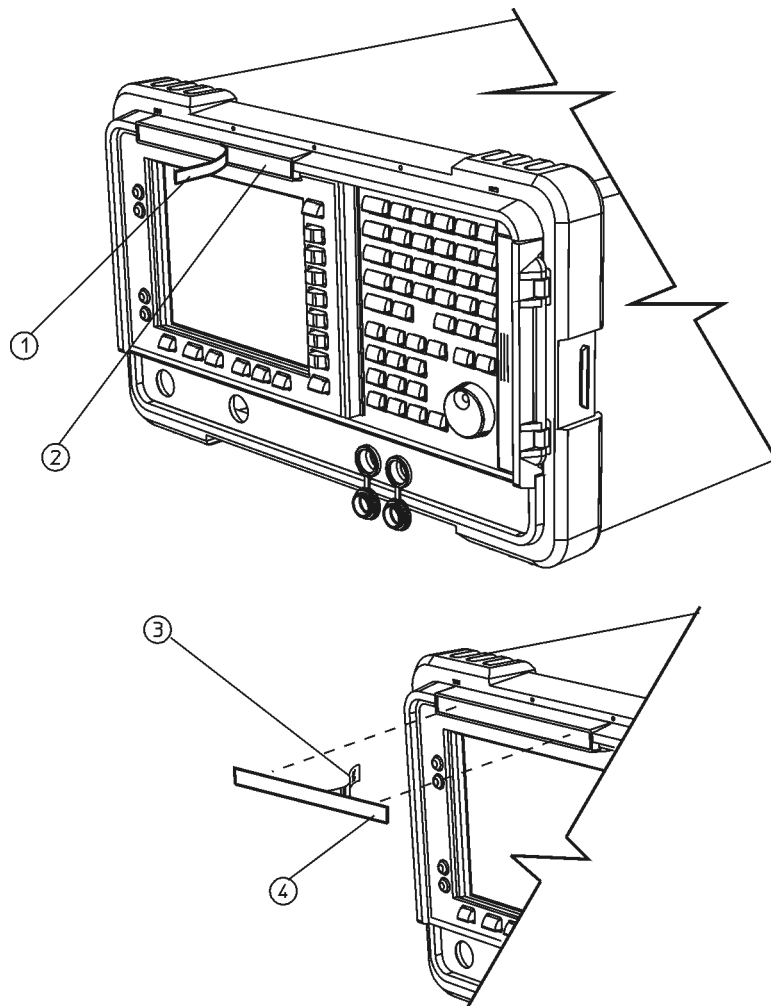
---

## A1MP16 Nameplate

### Removal and Replacement

- Step 1.** Remove the existing nameplate (1) as shown in Figure 6-12.
- Step 2.** Clean the surface (2) of any adhesive residue.
- Step 3.** Peel the backing (3) off the new nameplate.
- Step 4.** Place the new nameplate (4) as shown.

**Figure 6-12**      **Nameplate Replacement**



si7114b

## **Connector Label**

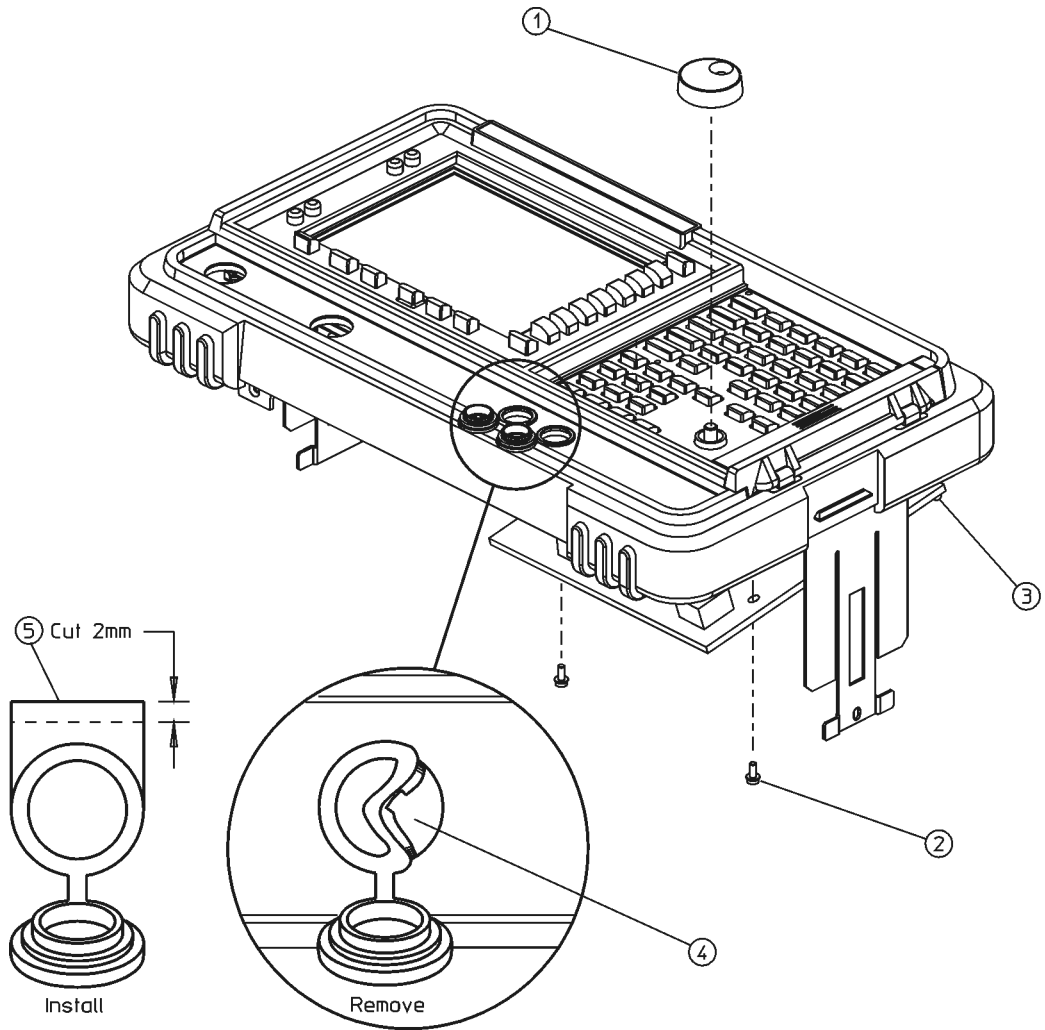
---

**CAUTION** Use ESD precautions when performing this replacement procedure.

### **Removal**

- Step 1.** Remove the instrument outer case. Refer to the removal procedure “Instrument Outer Case” on page 149.
- Step 2.** Remove the front frame assembly. Refer to the removal procedure “A1 Front Frame Assembly” on page 155.
- Step 3.** Remove the RPG knob. Refer to the removal procedure “A1A1 Front Panel Interface Board” on page 167.
- Step 4.** Remove the SNS connector, with a pair of C-clip extractors at the back of the front panel.
- Step 5.** Remove the two connector covers from the front panel by pinching them from the sides (**4**) and removing them through the front of the front frame assembly. See Figure 6-13.
- Step 6.** Peel off the old connector label (**1**) removing any residual adhesive with a sharp knife or razor blade. See Figure 6-14.

Figure 6-13 Connector Covers



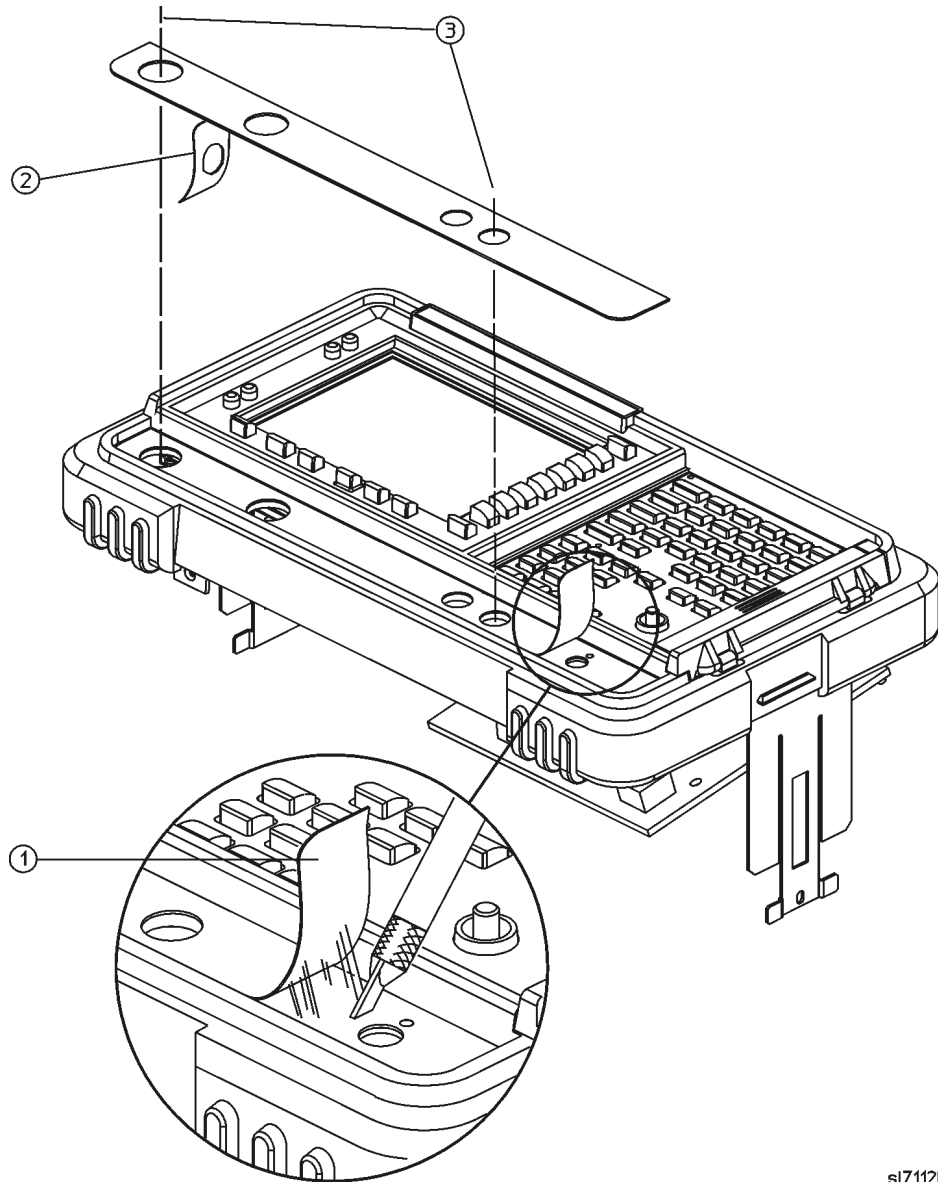
sl7111b

### **Installation**

Before installing the new connector label, ensure the surface is free from any adhesive residue from the old label. Failure to do so may result in an uneven appearance of the new label.

- Step 1.** Peel the backing ( 2 ) off the new label as show in Figure 6-14.
- Step 2.** Align and install the label by placing a finger in the SNS Serial Noise Source and EXT KEYBOARD holes. Observe the alignment of the INPUT and PROBE POWER holes ( 3 ).

**Figure 6-14** Connector Label Removal and Installation



sl7112b

---

**TIP**

It may be helpful to trim off about 2 mm of the tabs (5) on the connector covers prior to reinstalling them. This will help in aligning the covers. See Figure 6-13.

- Step 3.** Reinstall the two connector covers from the front panel by pinching them from the sides (4) and installing them through the front of the assembly. See Figure 6-13.
- Step 4.** Align the connector covers so they open downward as shown.

### **Replacement**

- Step 1.** Re-install or re-attach the front panel interface board. Refer to the replacement procedure “A1A1 Front Panel Interface Board” on page 167.
- Step 2.** Inspect the ribbon cables to the front panel interface board to ensure they have not come loose.
- Step 3.** Replace the RPG knob. It may be helpful to add a drop of isopropyl alcohol or water to the RPG to make it easier to press on the shaft.
- Step 4.** Re-install the front frame assembly. Refer to the replacement procedure “A1 Front Frame Assembly” on page 155.
- Step 5.** Re-install the instrument outer case. Refer to the replacement procedure “Instrument Outer Case” on page 149.

## Front Frame Subassemblies

In order to remove any of the following subassemblies, it is necessary to remove the A1 front frame assembly from the main chassis. Refer to the removal procedure “A1 Front Frame Assembly” on page 155.

After the subassembly is replaced, reconnect the front frame to the chassis. Refer to the replacement procedure for the “A1 Front Frame Assembly” on page 155.

Refer to Chapter 7, “Post-Repair Procedures,” for further information on the calibration and performance verification tests required after the assembly has been replaced.

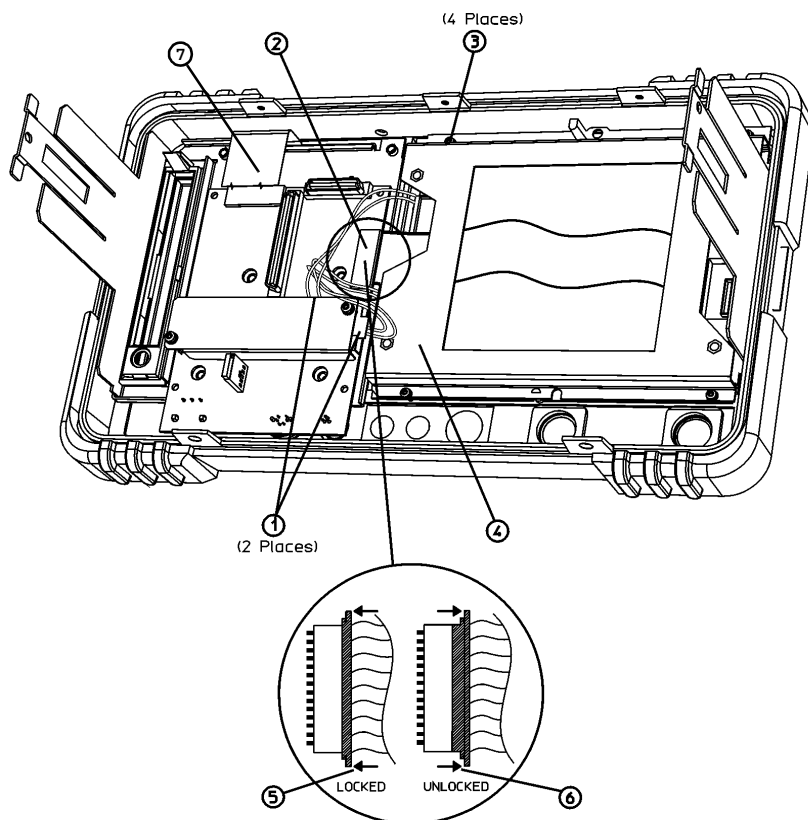
### CAUTION

Use ESD precautions when performing the following replacement procedures.

## A1A2 Display

Figure 6-15

### A1A2 Display Replacement





### Removal

Refer to Figure 6-15 for the following procedure.

- Step 1.** Place the front frame assembly face down on the work surface.
- Step 2.** Disconnect the two 2-wire backlight cables (1) from the front panel interface inverter board.
- Step 3.** Refer to Figure 6-15. Disconnect the ribbon cable W3 (2) from the front panel interface board.

---

**CAUTION** The W3 display ribbon cable connector (2) is delicate. Use a small screwdriver or similar tool, gently push the lock tabs out from the back of the connector. Excessive force on the locking tab can break the retaining clips, and if broken, board replacement is necessary.

---

- Step 4.** Remove the 4 screws (3) securing the display (in a bracket) (4) to the front frame.
- Step 5.** Carefully lift the display out of the front frame assembly.

### Replacement

---

**CAUTION** The display monitor comes with a protective plastic sheet over the glass. Remove this plastic very slowly to avoid ESD damage.

---

---

**CAUTION** The display's surface is very easily scratched. Avoid touching it with your bare hands or other objects. Use a blower to remove any dust from the display surface.

---

- Step 1.** Clean the inside of the lens that is attached to the front frame.
- Step 2.** Refer to Figure 6-16. Place the display (3) into the front frame assembly. Make sure that the cables are not pinched between the display and the front frame, and the W3 ribbon cable is not folded.
- Step 3.** Replace the 4 screws (3) that secure the display bracket to the front frame. Tighten them to 9 inch-pounds.
- Step 4.** Connect the W3 display ribbon cable (2) to the front panel interface board.

---

**TIP** An easy way to insert this delicate cable into the connector is to place your finger on the cable, in the center of the LCD display, and gently slide the cable toward the connector until they align. Then, providing guidance with the other hand as necessary, slide the cable until the end slips into the connector.

Ensure the cable end is seated completely and is aligned straight within the connector body.

Continue to hold the cable in place with your finger, and with the other hand gently press the locking tabs (5) into place. See Figure 6-15.

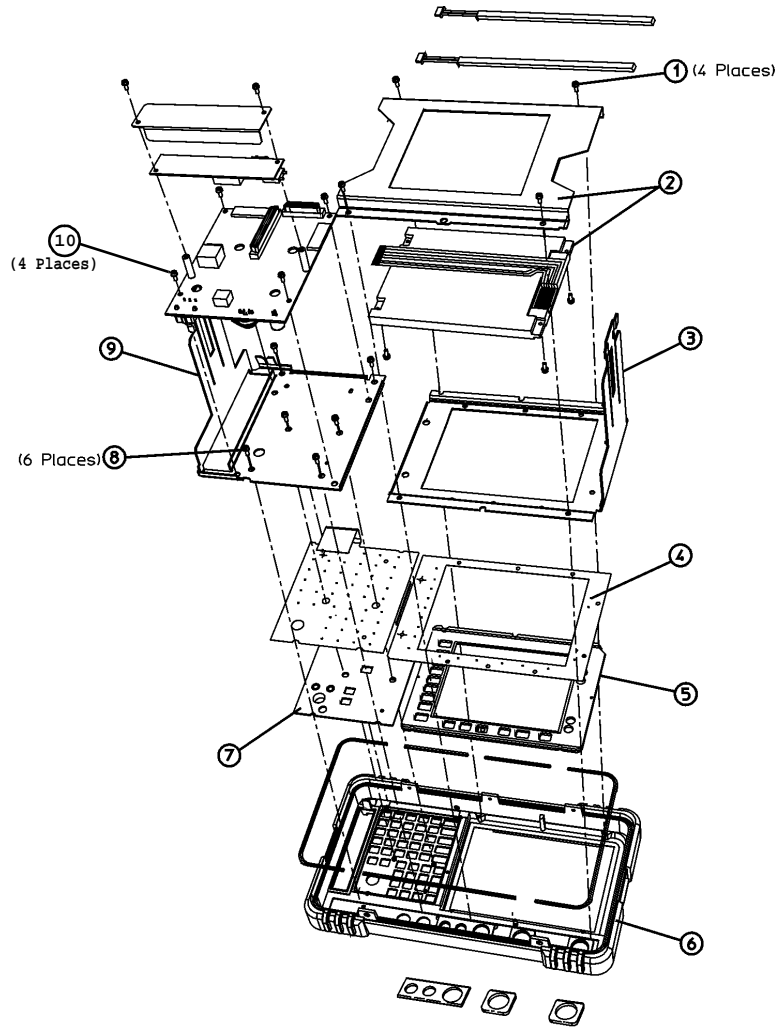
---

Replacing Assemblies  
Front Frame Subassemblies

**NOTE** If you experience display problems, check this connection.

**Step 5.** Connect the two backlight cables (1) to the front panel interface inverter board.

**Figure 6-16** Front Frame Assembly Parts



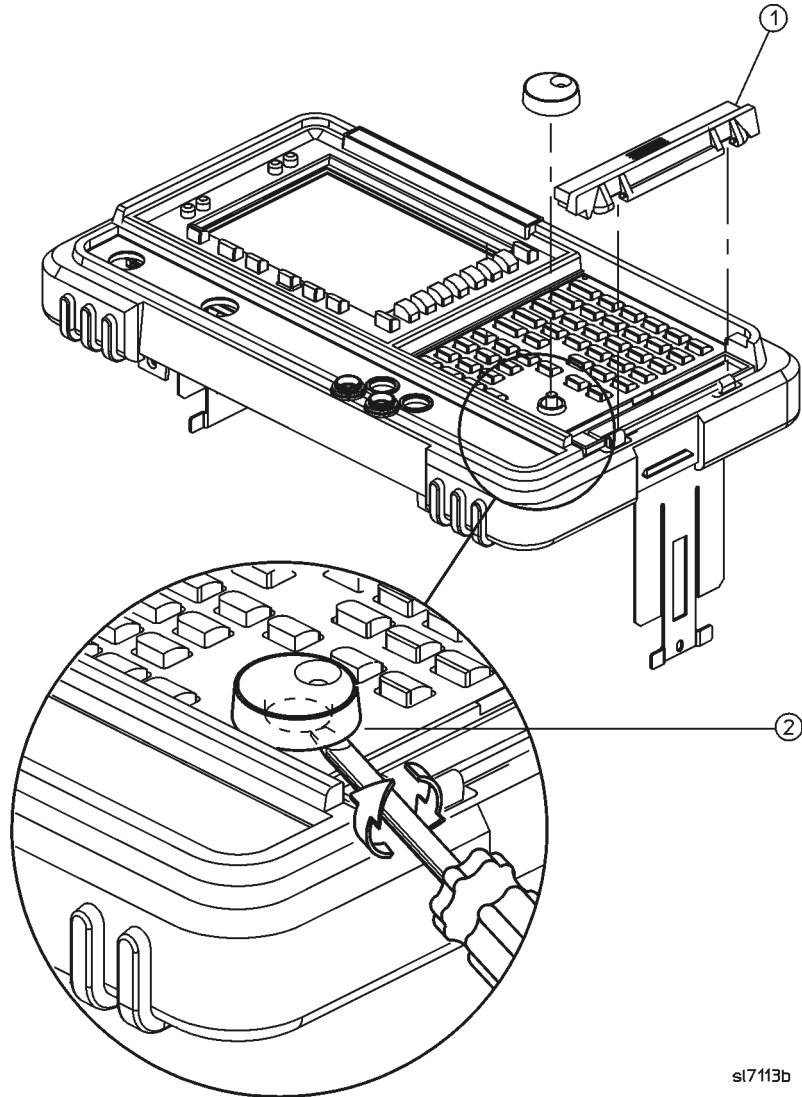
st7104b

## A1A1 Front Panel Interface Board

### Removal

- Step 1.** Refer to Figure 6-17. Remove the media door (1) from the front panel.
- Step 2.** Insert a flat-blade screwdriver under the RPG knob (2) as shown in Figure 6-17, and twist it to remove the knob.

**Figure 6-17**      **Removing the Knob**



st7113b

- Step 3.** Refer to Figure 6-15. Disconnect the two 2-wire backlight cables (1) from the inverter board.
- Step 4.** Disconnect the display ribbon cable W3 (2) and the keypad ribbon cable (7) from the front panel interface board.

Replacing Assemblies  
**Front Frame Subassemblies**

---

**CAUTION**

The display ribbon cable connector **(2)** is delicate. Refer to Figure 6-15. With a small screwdriver or similar tool, gently push the lock tabs **(6)** out from the back of the connector. Excessive force on the locking tab will break the retaining clips, and if broken, the board's replacement is necessary.

---

**Step 5.** Refer to Figure 6-16. Remove the 4 screws that secure the A1A1 front panel interface board **(10)** to the front frame.

**Step 6.** Remove the front panel interface board from the front frame assembly.

**Replacement**

**Step 1.** Place the front panel interface board **(10)** in the correct position in the front frame assembly.

**Step 2.** Replace the 4 screws that secure the board to the front frame. Tighten them to 9 inch-pounds.

**Step 3.** Connect the ribbon cable W3 **(2)** to the front panel interface board.

---

**TIP**

An easy way to insert this delicate cable into the connector is to place your finger on the cable, in the center of the LCD display, and gently slide the cable toward the connector until they align. Then, providing guidance with the other hand as necessary, slide the cable until the end slips into the connector.

Ensure the cable end is seated completely and is aligned straight within the connector body.

Continue to hold the cable in place with your finger, and with the other hand gently press the locking tabs **(5)** into place. See Figure 6-15.

---

**NOTE**

If you experience display problems, check the W3 display connection.

---

**Step 4.** Connect the keypad ribbon cable **(7)** to the front panel interface board.

**Step 5.** Reconnect the two 2-wire backlight cables **(1)** to the inverter board.

**Step 6.** Press the RPG knob onto its control shafts.

## **Front Panel RPG**

### **Removal/Replacement**

- Step 1.** Remove the front panel interface board. Refer to the removal procedure “A1A1 Front Panel Interface Board” on page 167.
- Step 2.** Unsolder the appropriate RPG and remove it from the front panel interface board.
- Step 3.** Place the new RPG in the correct position and resolder the leads.
- Step 4.** Replace the front panel interface board. Refer to the replacement procedure “A1A1 Front Panel Interface Board” on page 167.

## Keypad/Flex Circuit

### Removal

**Step 1.** Remove the RPG knob.

---

**TIP** To facilitate knob removal, slide any flat flexible material (such as a flat-blade screwdriver) under the knob and pry upward, refer to Figure 6-17.

---

**Step 2.** Remove the front panel interface board. Refer to the removal procedure “A1A1 Front Panel Interface Board” on page 167.

**Step 3.** Refer to Figure 6-16. Remove the 4 screws (1) that secure the display to the front frame.

**Step 4.** Remove the display assembly (2) then the support bracket (3).

**Step 5.** Remove the 6 screws (8) securing the subpanel assembly (9) to the front frame.

**Step 6.** Remove the subpanel assembly (9).

**Step 7.** Lift out the keypad/flex circuit (4) and the main keypad (7). Be careful to avoid touching the keypad contacts with your fingers.

### Replacement

**Step 1.** Refer to Figure 6-16. Place the main keypad (7) so it lays flat in the front frame (6). Be careful to avoid touching the keypad contacts with your fingers.

**Step 2.** Insert the flex circuit (4) so it aligns with the pegs on the front frame and lies flat.

**Step 3.** Replace the subpanel (9), and secure with the 6 screws (8). Tighten them to 9 inch-pounds.

---

**NOTE** If you are putting in a new flex circuit, it will need to be preformed in order to fit properly in the front frame. Slightly bend the circuit along the slits in two places between the main key section and the display section to conform to the contours of the front frame. Be careful to not bend the circuit too much (no more than a 90° angle), and do not crease it. This can damage the traces in the flex circuit.

---

**Step 4.** Replace the support bracket (3), along with the display (2) and secure with the 4 screws (1). Tighten them to 9 inch-pounds.

**Step 5.** Replace the front panel interface board. Refer to the replacement procedure “A1A1 Front Panel Interface Board” on page 167.

**Step 6.** Replace the RPG knobs.

## A1A3MP9 Lens/Keypad Assembly

### Removal

---

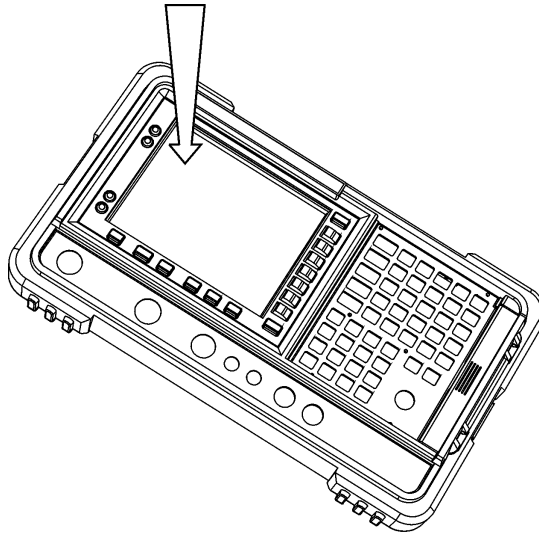
**NOTE** The lens/keypad assembly is pressed into place, using a strong adhesive instead of hardware. It is made of a plastic material and will bend but not break.

---

- Step 1.** Remove the keypad/flex circuit. Refer to the removal procedure “Keypad/Flex Circuit” on page 170.
- Step 2.** To remove the lens/keypad from the front frame, apply pressure from the front side. Using both thumbs, press in the corner of the lens as shown in Figure 6-18 until it pops out.

**Figure 6-18**

### Lens Removal



### Replacement

- Step 1.** Remove the paper covering the adhesive on the lens/keypad assembly.
- Step 2.** Carefully fit the new lens/keypad assembly into place in the front frame. Press along the edges of the lens from the inside to adhere it to the front frame.
- Step 3.** Make sure the inside of the lens is clean from contaminants, such as lint and fingerprints, before proceeding.
- Step 4.** Replace the main keypad, flex circuit, and subpanel assembly (with the display and front panel interface board attached). Refer to the replacement procedure “Keypad/Flex Circuit” on page 170.
- Step 5.** Replace the front panel interface board. Refer to the replacement procedure “A1A1 Front Panel Interface Board” on page 167.
- Step 6.** After the front frame is reattached to the chassis, remove the protective plastic covering from the lens.

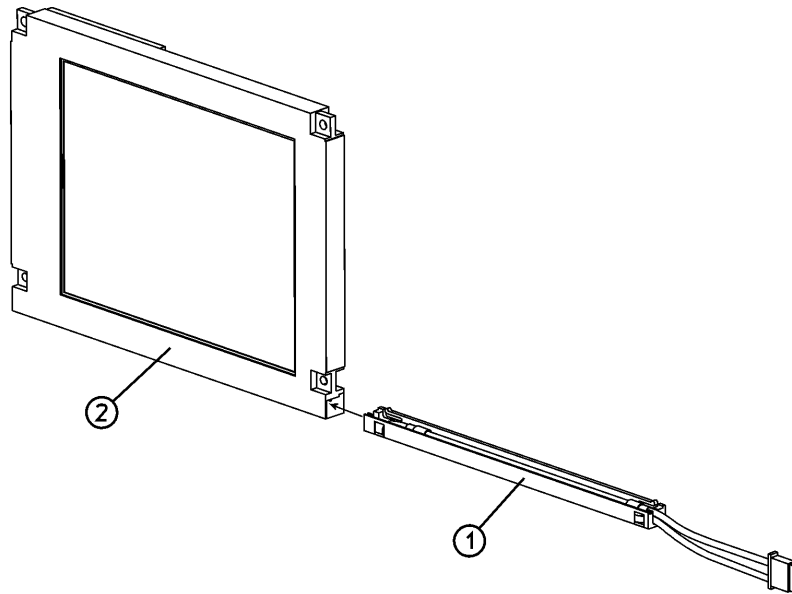
## A1A2DS1/A1A2DS2 Display Backlight

### Removal

- Step 1.** Remove the display. Refer to the removal procedure “A1A2 Display” on page 164.
- Step 2.** Figure 6-19. Loosen 2 frame retaining screws (1 turn) adjacent to the backlight being removed. Press the black locking tab (wire end) outward, and pull the backlight (1) out carefully. Repeat the operation for the other backlight.

Figure 6-19

### Display Backlight Replacement



### Replacement

---

**CAUTION** Do not touch the bulb encased in the plastic backlight assembly.

- Step 1.** Insert the new backlight assembly (1) by sliding it into the display, non-wired end first, taking care not to force it. It is keyed so it only fits one way. Slide it all the way in to the end of the casing.

---

**NOTE** It is recommended that both backlights be replaced at the same time, even though only one has failed. The remaining (functioning) backlight will likely fail shortly after the first backlight fails.

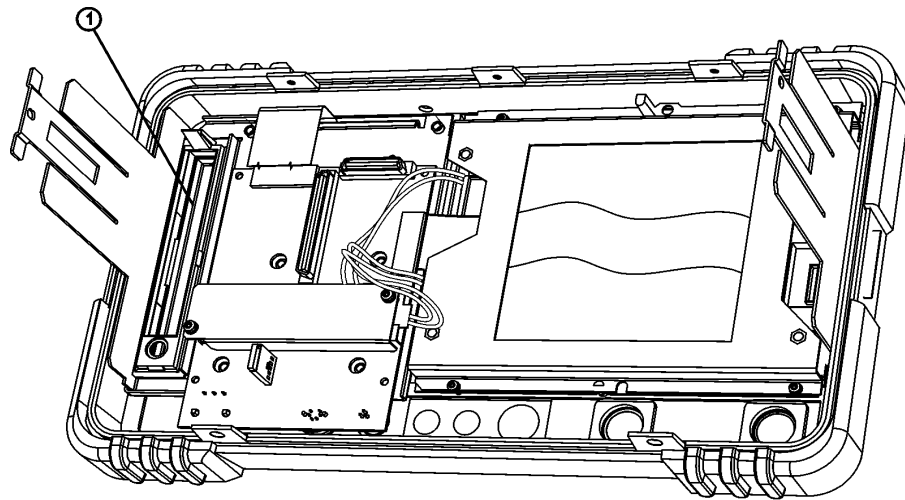
- Step 2.** Tighten the 4 screws that secure the backlight to the frame. Tighten them to 9 inch-pounds.
- Step 3.** Replace the display. Refer to the replacement procedure “A1A2 Display” on page 164.



### A1MP11 Media Door/Bezel

- Step 1.** The media door snaps on and off of the media bezel.
- Step 2.** Refer to Figure 6-20. To remove the media bezel (1), it is necessary to remove the front frame. Refer to the removal procedure “A1 Front Frame Assembly” on page 155.
- Step 3.** The bezel snaps into place. It can be removed by pressing the tabs together from the inside and pushing the bezel out of the front frame.

**Figure 6-20** Media Door/Bezel



sl7102b

---

## MP7 Vibration Support Bar

### Removal

- Step 1.** Referring to Figure 6-21, loosen, but do not remove, all 9 of the screws (1) securing the boards and blank panels at the rear of the chassis.

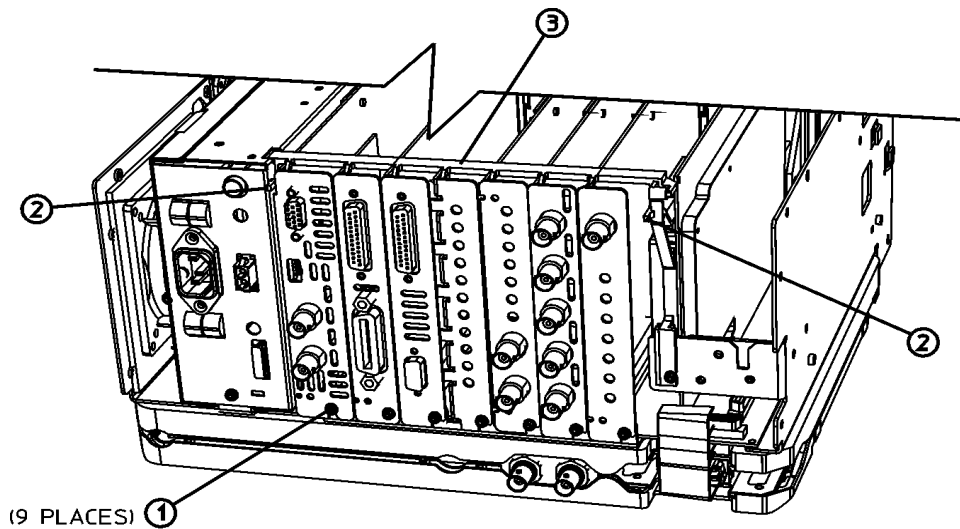
---

**CAUTION** The vibration support bar is fragile. When removing the bar use caution to avoid breaking it.

---

- Step 2.** On the vibration support bar, press in the locking tabs (2) and rotate the bar (3) upward. Remove the bar by sliding it out of the holes in each of the assemblies and lifting it up.

**Figure 6-21** Removing the Vibration Support Bar



sl754b

## Replacing the Vibration Support Bar

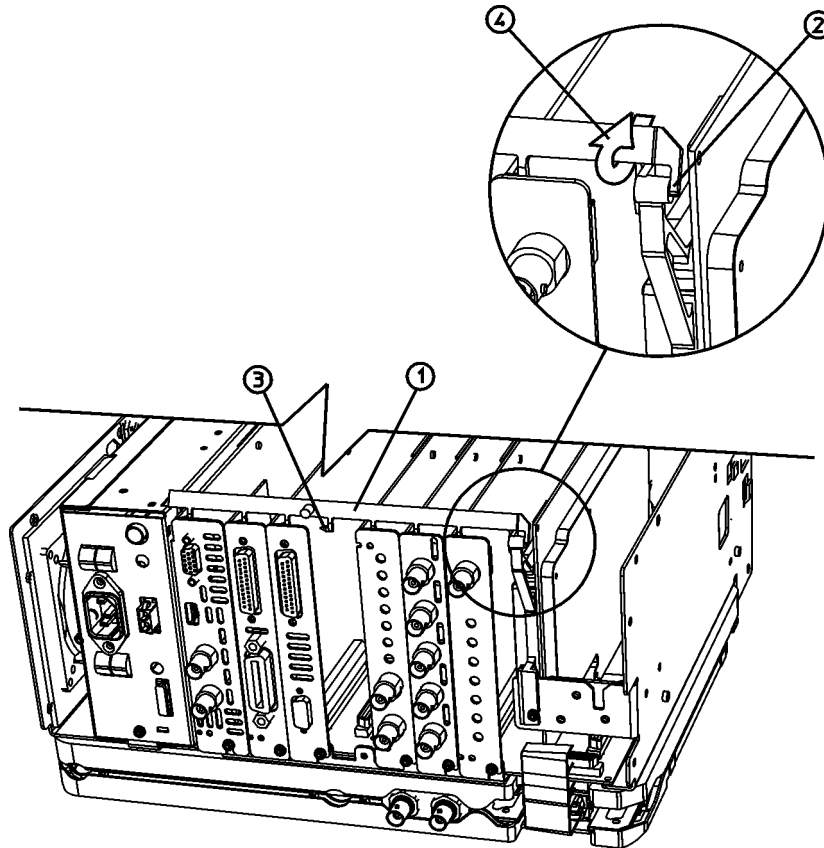
- Step 1.** Referring to Figure 6-22, replace the vibration support bar (1) as follows:
1. Position the vibration support bar (1) as shown and insert the hook (2) into the A2 front end assembly's support arm.
  2. Engage each hook (3) of the other assemblies or blank panels.
  3. After you position each of the assemblies or blank panels, rotate (4) the support bar to lock them in place.
  4. Referring to Figure 6-23, make sure that the tab (1) is positioned in the slot of the power supply chassis and the vibration bar is fully seated and locked (2) into position.

---

**CAUTION** The vibration support bar can easily be broken if it is forced. Install it with care.

- Step 2.** Refer to Figure 6-21. Tighten the 9 screws (1) that were loosened in the removal procedure to 9 inch-pounds.

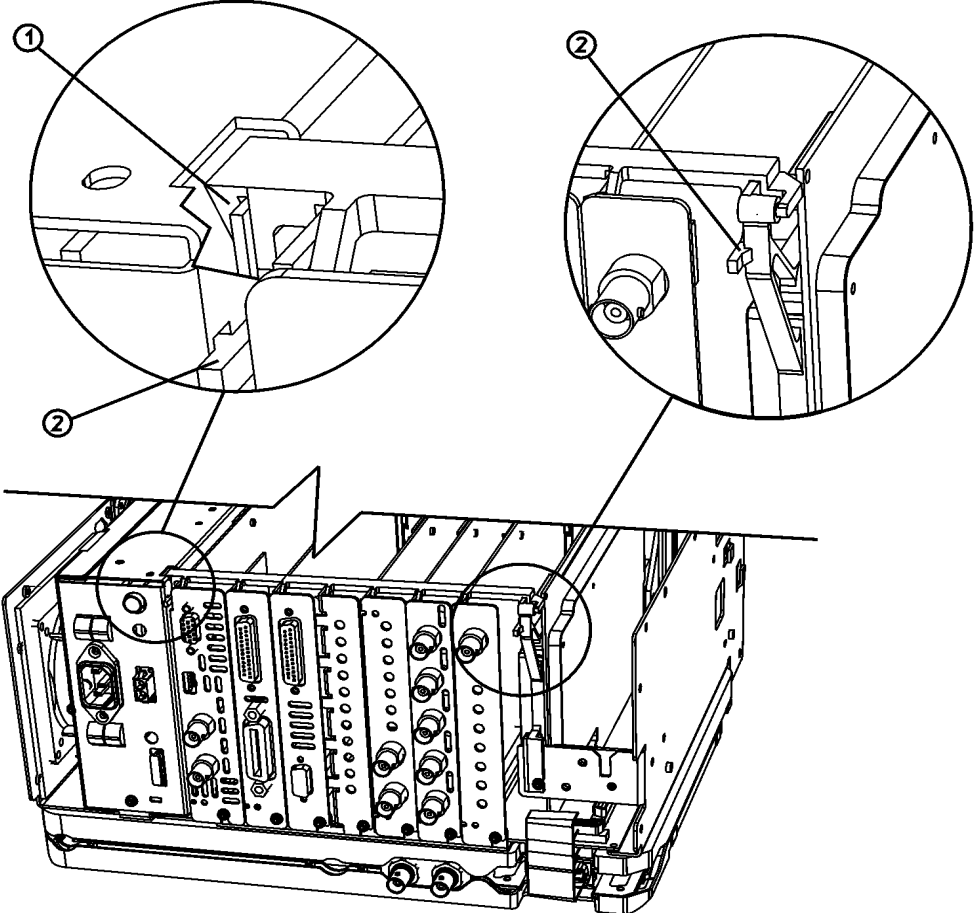
**Figure 6-22** Installing the Vibration Support Bar



617536

Figure 6-23

Seating the Vibration Support Bar



sl755b

---

## A3 Microwave Front End Assembly

(N8974A and 8975A)

---

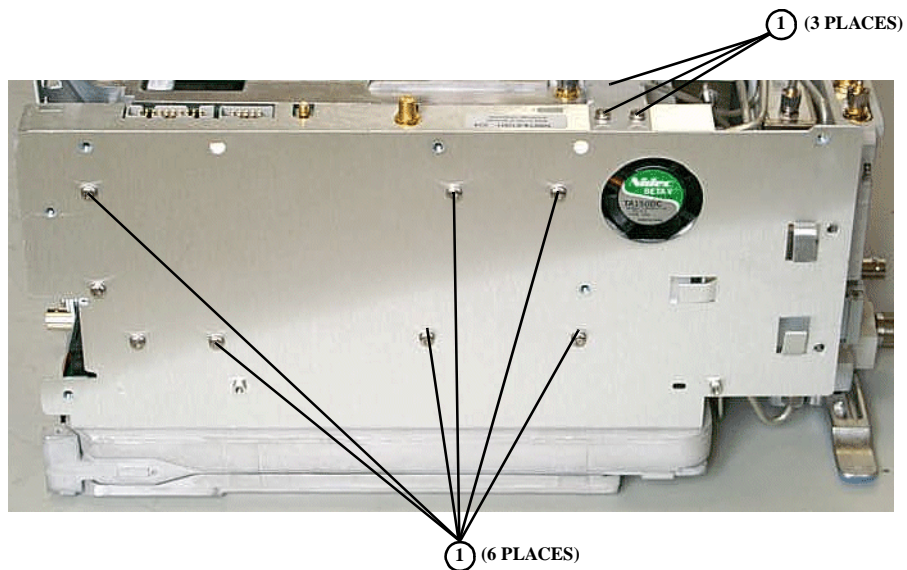
**CAUTION** Use ESD precautions when performing this replacement procedure.

---

### Removal

- Step 1.** Remove the instrument chassis cover. Refer to the removal procedure “Chassis Cover” on page 153.
- Step 2.** Extend the A1 front frame assembly. Refer to the extension procedure “Extension of the Front Frame Assembly” on page 155.
- Step 3.** Refer to Figure 6-24. Remove the 9 screws (1), (6 from the side, 3 from the top).
- Step 4.** Disconnect the W6 semi-rigid from the A3J1 connector on the microwave front end.
- Step 5.** Disconnect the W7 semi-rigid from the A3J2 connector on the microwave front end.
- Step 6.** Disconnect the W14 semi-rigid from the A3J5 connector on the microwave front end.
- Step 7.** Carefully pull up on the microwave front end assembly to remove it from the motherboard connector.

**Figure 6-24** A3 Microwave Front End Hardware



## **Replacement**

---

**CAUTION**

Use ESD precautions when performing the following replacement procedures.

- Step 1.** Carefully plug the microwave front end assembly into the motherboard.
- Step 2.** Replace the 3 semi-rigids to the microwave front end. Torque to 5 inch-pounds.
- Step 3.** Refer to Figure 6-24. Replace the 9 screws. Tighten them to 9 inch-pounds.
- Step 4.** Reconnect the A1 front frame to the chassis. Refer to the replacement procedure “A1 Front Frame Assembly” on page 155.
- Step 5.** Replace the chassis cover. Refer to the replacement procedure “Chassis Cover” on page 153.
- Step 6.** Replace the outer case. Refer to the replacement procedure “Instrument Outer Case” on page 149.
- Step 7.** Refer to Chapter 7, “Post-Repair Procedures,” for further information on the calibration and performance verification tests required after the assembly has been replaced.

---

## A2 RF Front End

---

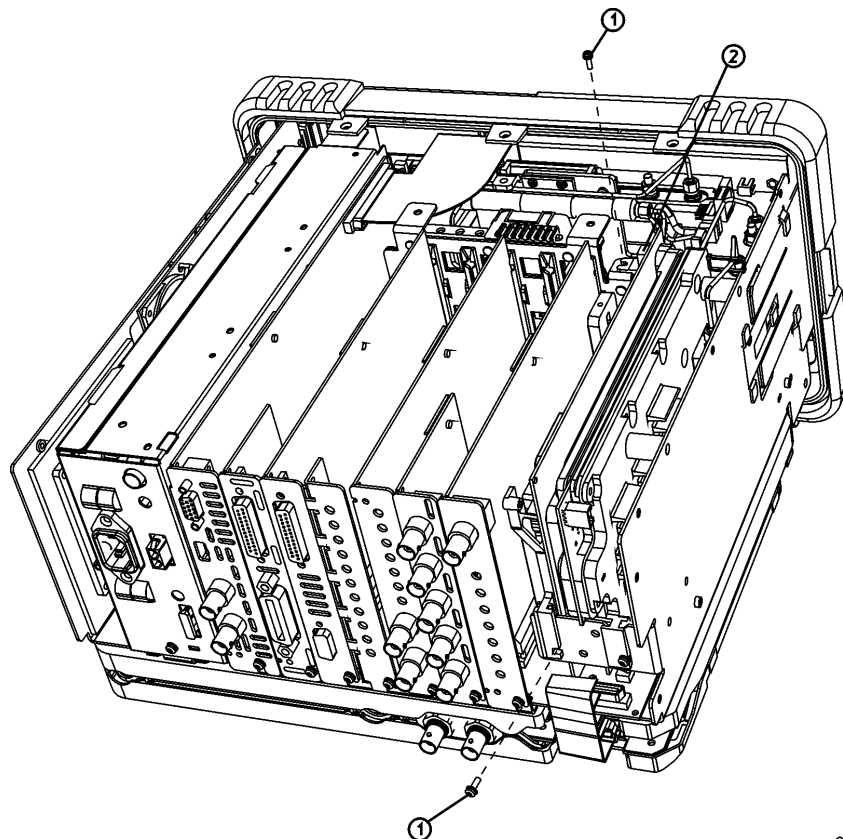
**CAUTION** Use ESD precautions when performing this replacement procedure.

---

### Removal

- Step 1.** Remove the instrument chassis cover. Refer to the removal procedure “Chassis Cover” on page 153.
- Step 2.** Remove the vibration support bar. Refer to the removal procedure “MP7 Vibration Support Bar” on page 174.
- Step 3.** Refer to Figure 6-25. Remove the 2 screws (1) securing the A2 front end assembly to the chassis. (On the N8974A and N8975A models remove 4 screws.)
- Step 4.** Disconnect the W15 coaxial cable from the A2J3 connector on the front end assembly.
- Step 5.** Disconnect the 2 semi-rigids W8 and W13 from the A2J3 and A2J1 respectively on the front end assembly.
- Step 6.** Carefully lift the front end assembly to remove it from the motherboard connector.

**Figure 6-25** A2 Front End Assembly



sl767b

## **Replacement**

- Step 1.** Carefully plug the front end assembly into the motherboard.
- Step 2.** Refer to Figure 6-25. Replace the 2 screws (**1**) that secure the front end assembly to the chassis. Tighten them to 9 inch-pounds. (On the N8974A and N8975A models replace 4 screws.)
- Step 3.** Connect the 2 semi-rigids W8 and W13 to the front end assembly. Torque to 5 inch-pounds.
- Step 4.** Connect the W15 coaxial cable to the front end assembly. Torque to 5 inch-pounds.
- Step 5.** Replace the vibration support bar. Refer to the replacement procedure “MP7 Vibration Support Bar” on page 174.
- Step 6.** Replace the chassis cover. Refer to the replacement procedure “Chassis Cover” on page 153.
- Step 7.** Replace the outer case. Refer to the replacement procedure “Instrument Outer Case” on page 149.
- Step 8.** Refer to Chapter 7, “Post-Repair Procedures,” for further information on the calibration and performance verification tests required after the assembly has been replaced.



---

## A4 Processor Assembly

---

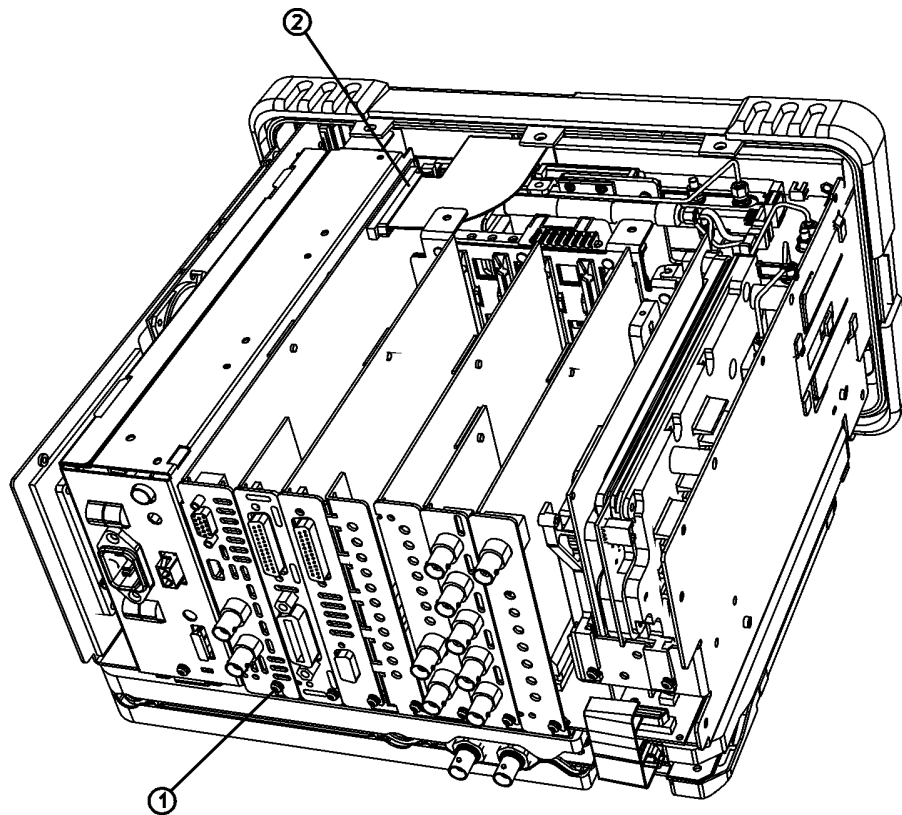
**CAUTION** Use ESD precautions when performing this replacement procedure.

---

### Removal

- Step 1.** Remove the instrument chassis cover. Refer to the removal procedure “Chassis Cover” on page 153.
- Step 2.** Remove the vibration support bar. Refer to the removal procedure “MP7 Vibration Support Bar” on page 174.
- Step 3.** Refer to Figure 6-26. Remove the single screw (1) securing the A4 processor assembly to the chassis.
- Step 4.** Disconnect the front panel ribbon cable W1 (2) from the processor assembly.
- Step 5.** Carefully lift the processor assembly to remove it from the motherboard connector.

**Figure 6-26** A4 Processor Assembly



sl785b

## **Replacement**

- Step 1.** Carefully plug the processor assembly into the motherboard.
- Step 2.** Refer to Figure 6-26. Replace the single screw **(1)** that secures the processor assembly to the chassis, but do not fully tighten.
- Step 3.** Reconnect the front panel ribbon cable W1 **(2)** to the processor assembly.
- Step 4.** Replace the vibration support bar. Refer to the replacement procedure “MP7 Vibration Support Bar” on page 174.
- Step 5.** Tighten the screw **(1)** to 9 inch-pounds.
- Step 6.** Replace the chassis cover. Refer to the replacement procedure “Chassis Cover” on page 153.
- Step 7.** Replace the outer case. Refer to the replacement procedure “Instrument Outer Case” on page 149.
- Step 8.** Refer to Chapter 7, “Post-Repair Procedures,” for further information on the calibration and performance verification tests required after the assembly has been replaced.

---

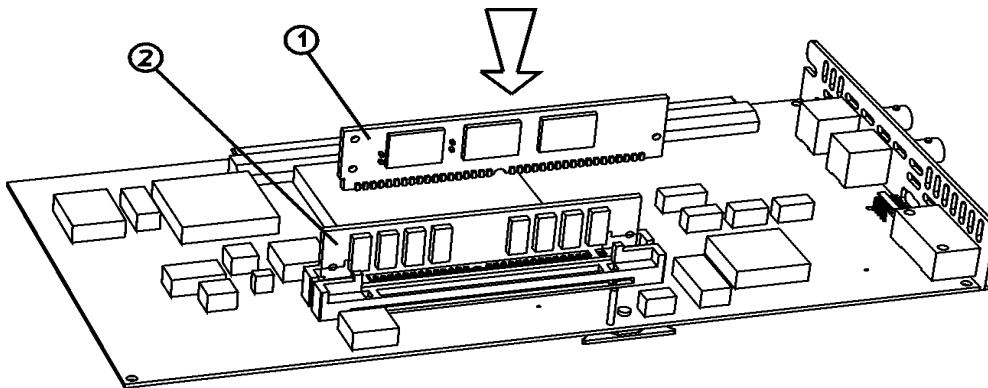
## A4A1 and A4A2 Flash and DRAM SIMM

**CAUTION** Use ESD precautions when performing this replacement procedure.

### Removal and Replacement

- Step 1.** Remove the A4 processor assembly. Refer to the removal procedure “A4 Processor Assembly” on page 181.
- Step 2.** Refer to Figure 6-27. Carefully remove the flash SIMM (1) or the DRAM SIMM (2).
- Step 3.** Replace the flash SIMM (1) or the DRAM SIMM (2).
- Step 4.** Replace the A4 processor assembly. Refer to the replacement procedure “A4 Processor Assembly” on page 181.
- Step 5.** Refer to Chapter 7, “Post-Repair Procedures,” for further information on the calibration and performance verification tests required after the assembly has been replaced.

**Figure 6-27** Flash SIMM and DRAM SIMM



sl786b

---

**NOTE** Ensure that after either of these parts have been replaced that you follow the procedure in “Firmware Installation Procedure” on page 10 and reload the firmware.

---

---

## **A4BT1 Battery**

---

**CAUTION** Use ESD precautions when performing this replacement procedure.

---

**WARNING** **There is a danger of explosion if the battery is incorrectly replaced. Replace only with the same or equivalent type recommended. Discard used batteries according to manufacturer’s instruction.**

---



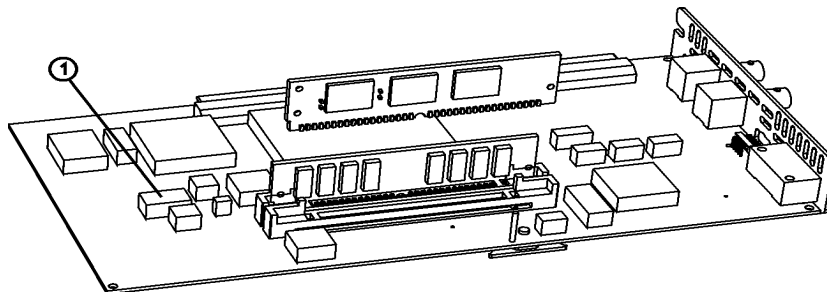
**DO NOT THROW BATTERIES AWAY BUT COLLECT AS SMALL CHEMICAL WASTE.**

sk780a

### **Removal and Replacement**

- Step 1.** Remove the A4 processor assembly from the instrument. Refer to the removal procedure “A4 Processor Assembly” on page 181.
- Step 2.** Refer to Figure 6-28. Gently pry the A4BT1 lithium battery from the processor board.
- Step 3.** Insert the new battery, ensuring proper polarity as indicated on the socket.
- Step 4.** Replace the processor assembly in the instrument. Refer to the replacement procedure “A4 Processor Assembly” on page 181.
- Step 5.** Refer to Chapter 7, “Post-Repair Procedures,” for further information on the calibration and performance verification tests required after the assembly has been replaced.

**Figure 6-28 Processor Battery Location**



si759b

---

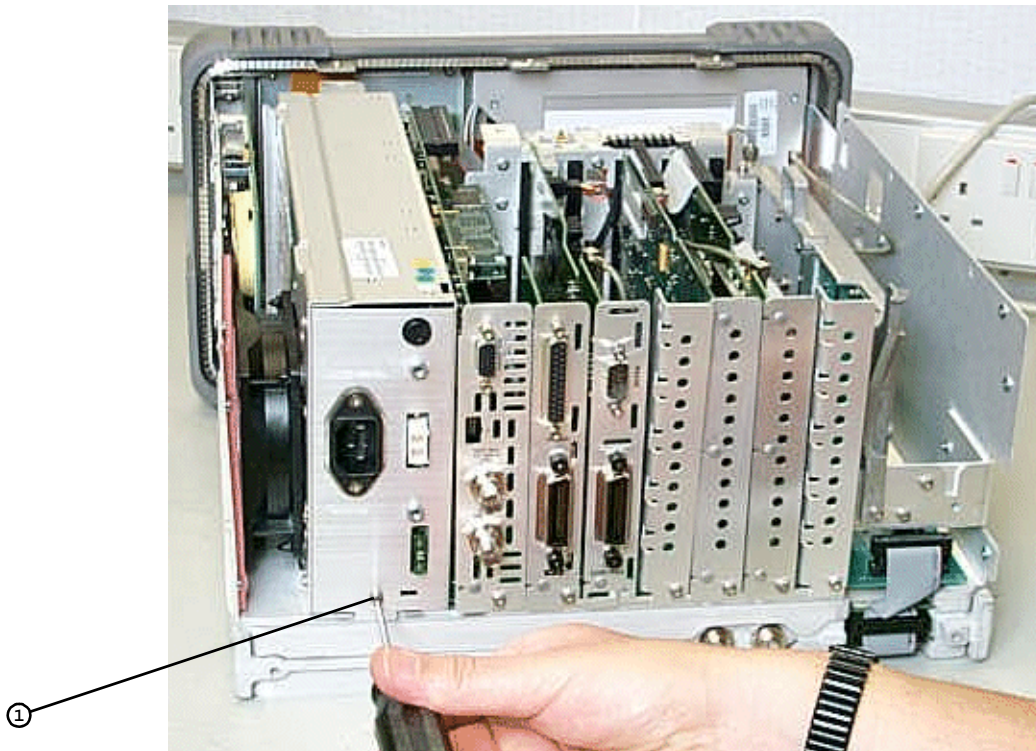
## A5 Power Supply

**CAUTION** Use ESD precautions when performing this replacement procedure.

### Removal

- Step 1.** Remove the instrument chassis cover. Refer to the removal procedure “Chassis Cover” on page 153.
- Step 2.** Remove the vibration support bar. Refer to the removal procedure “MP7 Vibration Support Bar” on page 174.
- Step 3.** Extend the A1 front frame assembly. Refer to the extension procedure “A1 Front Frame Assembly” on page 155.
- Step 4.** Refer to Figure 6-29. Remove the single screw (1) securing the A5 power supply assembly to the chassis at the rear of the instrument.
- Step 5.** Carefully pull up on the power supply assembly to remove it from motherboard connector.

**Figure 6-29** A5 Power Supply



## **Replacement**

- Step 1.** Carefully plug the A5 power supply assembly into the motherboard.
- Step 2.** Refer to Figure 6-29. Replace the single screw **(1)** that secures the power supply to the chassis, but do not fully tighten.

---

**NOTE**

Ensure you change the switch at the rear of the A5 power supply, so the power is set to **PWR NORM**. Refer to the Overview of the Rear Panel section of the User's Guide for information on this switch.

---

- Step 3.** Reconnect the front frame assembly to the chassis. Refer to the replacement procedure "A1 Front Frame Assembly" on page 155.
- Step 4.** Replace the vibration support bar. Refer to the replacement procedure "MP7 Vibration Support Bar" on page 174.
- Step 5.** Tighten the screw **(1)** to 9 inch-pounds.
- Step 6.** Replace the chassis cover. Refer to the replacement procedure "Chassis Cover" on page 153.
- Step 7.** Replace the outer case. Refer to the replacement procedure "Instrument Outer Case" on page 149.
- Step 8.** Refer to Chapter 7, "Post-Repair Procedures," for further information on the calibration and performance verification tests required after the assembly has been replaced.

---

## A5B1 Fan

---

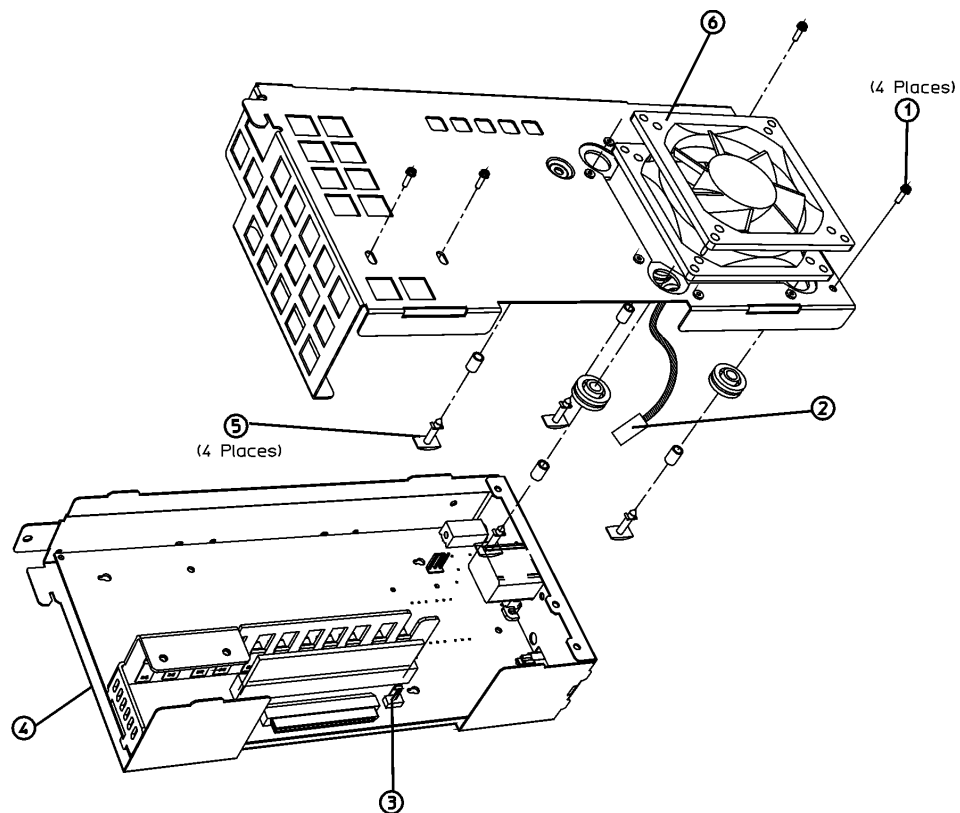
**CAUTION** Use ESD precautions when performing this replacement procedure.

---

### Removal

- Step 1.** Remove the power supply assembly. Refer to the removal procedure “A5 Power Supply” on page 185.
- Step 2.** Unplug the fan wires (2) from the power supply board connector (3) inside the assembly. Refer to Figure 6-30.
- Step 3.** Refer to Figure 6-30. Remove the 4 screws (1) securing the top cover to the power supply assembly.

**Figure 6-30** Power Supply Cover Removal



- Step 4.** Remove the top cover.
- Step 5.** Locate the 4 plastic rivets (5) that secure the fan (6) to the cover.
- Step 6.** The rivets are not reusable and need to be cut off in order to change the fan.
- Step 7.** The fan can be removed after the 4 rivets are cut out.

## Replacement

**Step 1.** Position the fan on the outside of the power supply cover so that the fan wires go through the opening of the cover and are aligned with the notch. Be careful not to pinch the fan wires against the cover.

---

**NOTE**

Be careful to install the fan so that the arrow indicating the direction of the air flow, (on the body of the fan), is pointing away from the cover. This will ensure the proper air flow through the instrument and exiting through the side panel.

---

**Step 2.** Refer to Figure 6-30. Assemble the bushing, grommet, and rivet as shown in 4 places.

**Step 3.** Replace the power supply cover, with fan, on the power supply assembly. Make sure the lip on the top cover catches underneath (4) the bottom cover.

**Step 4.** Replace the 4 screws (1) that secure the top cover to the power supply assembly. Tighten them to 9 inch-pounds.

**Step 5.** Plug the fan connector into the power supply board.

**Step 6.** Replace the power supply assembly. Refer to the replacement procedure “A5 Power Supply” on page 185.

**Step 7.** Refer to Chapter 7, “Post-Repair Procedures,” for further information on the calibration and performance verification tests required after the assembly has been replaced.



---

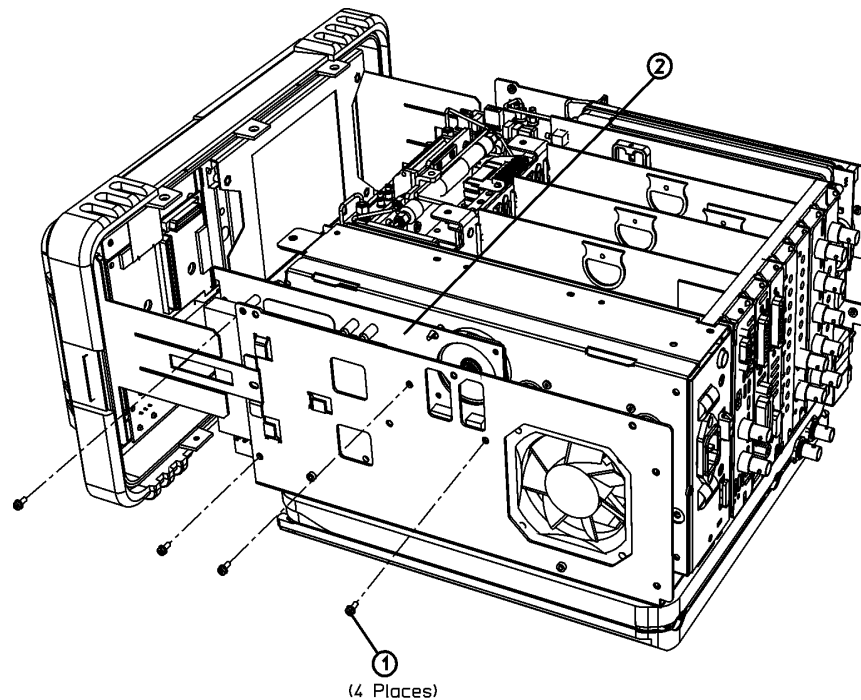
## A6 Floppy Disc Assembly

**CAUTION** Use ESD precautions when performing this replacement procedure.

### Removal

- Step 1.** Remove the instrument chassis cover. Refer to the removal procedure “Chassis Cover” on page 153.
- Step 2.** Extend the A1 front frame. Refer to the extension procedure “Extension of the Front Frame Assembly” on page 155.
- Step 3.** Refer to Figure 6-31. Remove the 4 screws (1) securing the A6 floppy assembly (2) to the side frame.
- Step 4.** Carefully pull up on the floppy assembly to remove it from the motherboard connector.

**Figure 6-31** A6 Floppy Disc Assembly Removal



sl756b

### **Replacement**

- Step 1.** Carefully plug the A6 floppy assembly into the motherboard.
- Step 2.** Refer to Figure 6-31. Replace the 4 screws **(1)** that secure the floppy assembly **(2)** to the side chassis. Tighten them to 9 inch-pounds.
- Step 3.** Reconnect the A1 Front Frame to the chassis. Refer to the replacement procedure “A1 Front Frame Assembly” on page 155.
- Step 4.** Replace the chassis cover. Refer to the replacement procedure “Chassis Cover” on page 153.
- Step 5.** Replace the outer case. Refer to the replacement procedure “Instrument Outer Case” on page 149.
- Step 6.** Refer to Chapter 7, “Post-Repair Procedures,” for further information on the calibration and performance verification tests required after the assembly has been replaced.

## **A7 Motherboard Assembly**

---

**CAUTION**

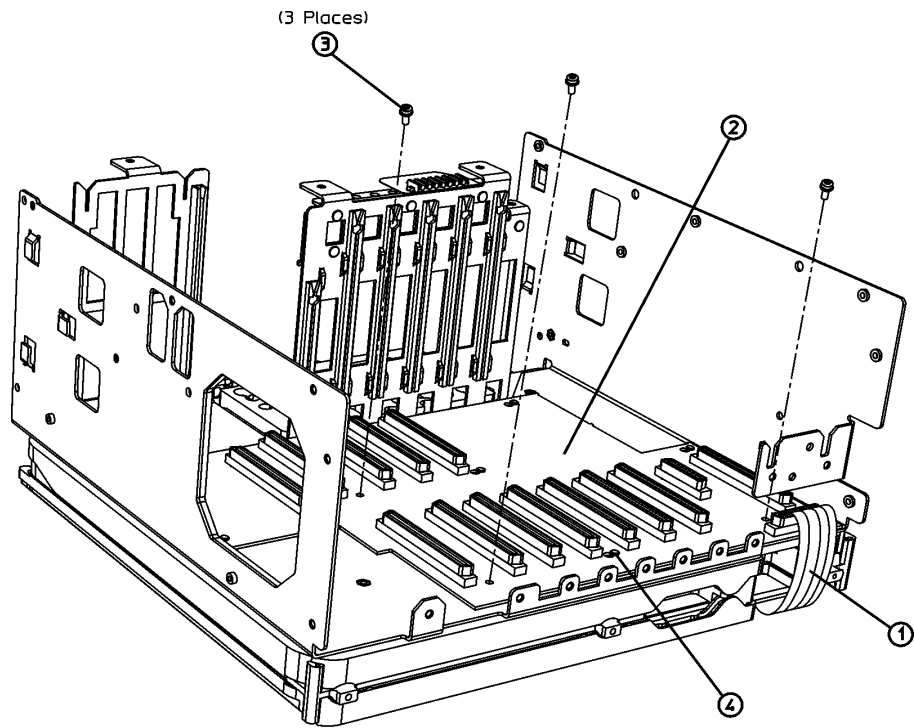
Use ESD precautions when performing this replacement procedure.

### **Removal**

- Step 1.** Remove the instrument outer case. Refer to the removal procedure “Instrument Outer Case” on page 149.
- Step 2.** Remove the instrument chassis cover. Refer to the removal procedure “Chassis Cover” on page 153.
- Step 3.** Extend the A1 front frame. Refer to the extension procedure “A1 Front Frame Assembly” on page 155.
- Step 4.** Remove the vibration support bar. Refer to the removal procedure “MP7 Vibration Support Bar” on page 174.
- Step 5.** Remove the A6 floppy drive assembly. Refer to the removal procedure “A6 Floppy Disc Assembly” on page 189.
- Step 6.** On models N8974A and N8975A, remove the A3 microwave front end assembly. Refer to the removal procedure “A3 Microwave Front End Assembly” on page 177.
- Step 7.** Remove the A2 front end assembly. Refer to the removal procedure “A2 RF Front End” on page 179.
- Step 8.** Remove the A4 processor assembly. Refer to the removal procedure “A4 Processor Assembly” on page 181.
- Step 9.** Remove the A5 power supply assembly. Refer to the removal procedure “A5 Power Supply” on page 185.
- Step 10.** Remove all card cage assemblies from the motherboard. Refer to the removal procedure “Card Cage Assemblies” on page 194.

Figure 6-32

A7 Motherboard Removal



sl757b

- Step 11.** Refer to Figure 6-32. Disconnect the RF ribbon cable W4 (1) from the motherboard (2).
- Step 12.** Remove the 3 screws (3) as indicated in Figure 6-32.
- Step 13.** Slide the motherboard sideways to disengage the shoulder lock standoffs (4), and lift the motherboard out of the chassis.

## **Replacement**

- Step 1.** Refer to Figure 6-32. Carefully place the motherboard (2) into the chassis.
- Step 2.** Slide the motherboard sideways to engage the shoulder locks (4) on the chassis.
- Step 3.** Replace the 3 screws (3) that secure the motherboard to the chassis. Tighten them to 9 inch-pounds.
- Step 4.** Refer to Figure 6-32. Connect the RF ribbon cable W4 (1) to the motherboard.
- Step 5.** Replace the A5 power supply assembly. Refer to the replacement procedure “A5 Power Supply” on page 185.
- Step 6.** Replace the A4 processor assembly. Refer to the replacement procedure “A4 Processor Assembly” on page 181.
- Step 7.** Replace the A2 front end assembly. Refer to the replacement procedure “A2 RF Front End” on page 179.
- Step 8.** Replace the A3 front end assembly, if applicable. Refer to the replacement procedure “A3 Microwave Front End Assembly” on page 177.
- Step 9.** Replace the A6 floppy disc assembly. Refer to the replacement procedure “A6 Floppy Disc Assembly” on page 189.
- Step 10.** Replace the card cage assemblies. Refer to the replacement procedure “Card Cage Assemblies” on page 194.
- Step 11.** Reconnect the A1 front frame to the chassis. Refer to the replacement procedure “A1 Front Frame Assembly” on page 155.
- Step 12.** Replace the vibration support bar. Refer to the replacement procedure “MP7 Vibration Support Bar” on page 174.
- Step 13.** Tighten all the screws (1) to 9 inch-pounds. Refer to Figure 6-34.
- Step 14.** Replace the chassis cover. Refer to the replacement procedure “Chassis Cover” on page 153.
- Step 15.** Replace the outer case. Refer to the replacement procedure “Instrument Outer Case” on page 149.
- Step 16.** Refer to Chapter 7, “Post-Repair Procedures,” for further information on the calibration and performance verification tests required after the assembly has been replaced.

---

## Card Cage Assemblies

### GPIB, RS-232, Frequency Extension, DSP, IF

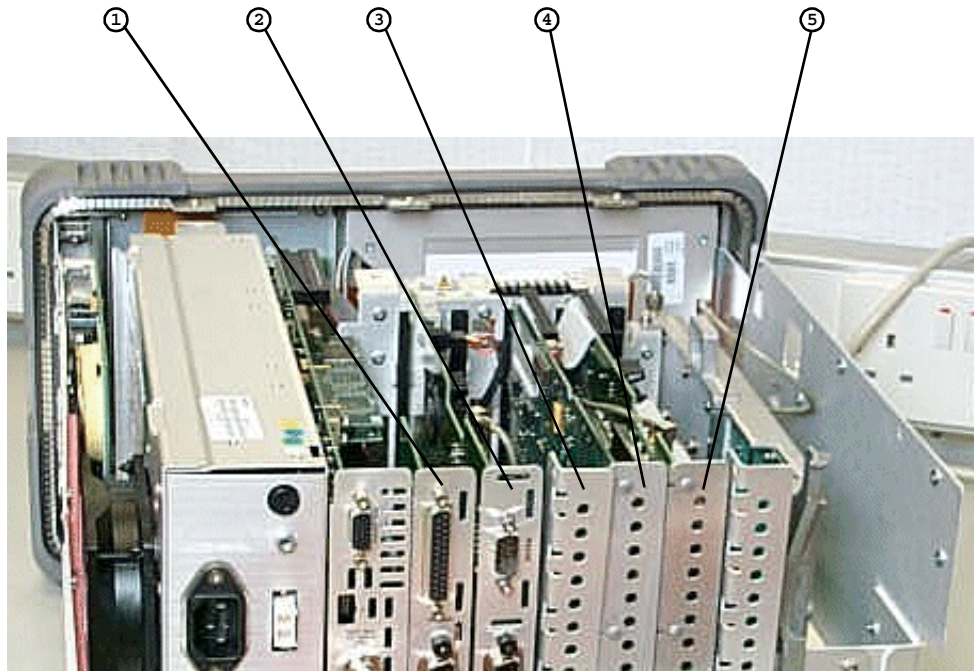
---

**CAUTION** Use ESD precautions when performing this replacement procedure.

**The following procedure can be used for all of the Card Cage assemblies:**

- A7A1 GPIB/Parallel Assembly (1)
- A7A2 RS-232/SIB Assembly (2)
- A7A3 Frequency Extension Assembly (N8974A and N8975A) (3)
- A7A4 DSP Assembly (4)
- A7A5 IF Assembly (5)

**Figure 6-33** Card Cage Assembly Locations

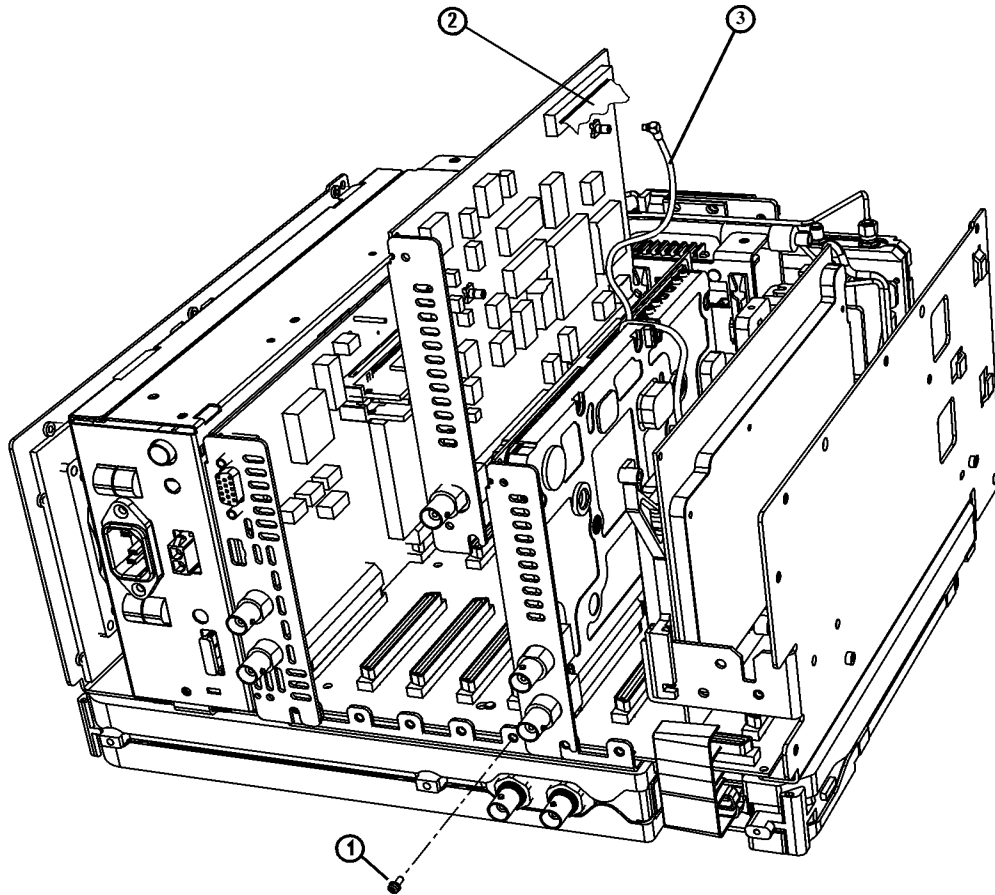


#### Removal

- Step 1.** Remove the instrument chassis cover. Refer to the removal procedure “Chassis Cover” on page 153.
- Step 2.** Remove the vibration support bar. Refer to the removal procedure “MP7 Vibration Support Bar” on page 174.
- Step 3.** Locate the assembly to be removed.

**Step 4.** Refer to Figure 6-34. Remove the single screw (1) securing the card cage assembly to the chassis.

**Figure 6-34** Card Cage Hardware



sl73c

**Step 5.** Remove the assembly and disconnect any cables, for example, when removing the DSP assembly, disconnect the ribbon cable (2) and the clock cable (3) from the DSP assembly

**Step 6.** Carefully pull up on the assembly to remove it from the motherboard connector.

Replacing Assemblies  
**Card Cage Assemblies**

**Replacement**

- Step 1.** Carefully plug the assembly into the motherboard.
- Step 2.** Replace the assembly and reconnect any cables, for example, replace the DSP assembly, connect the ribbon cable (2) and the clock cable (3) to the DSP assembly.
- Step 3.** Refer to Figure 6-34. Replace the single screw (1) that secures the card cage assembly to the chassis, but do not fully tighten.
- Step 4.** Replace the vibration support bar. Refer to the replacement procedure “MP7 Vibration Support Bar” on page 174.
- Step 5.** Tighten the screw (1) to 9 inch-pounds.
- Step 6.** Replace the chassis cover. Refer to the replacement procedure “Chassis Cover” on page 153.
- Step 7.** Replace the outer case. Refer to the replacement procedure “Instrument Outer Case” on page 149.
- Step 8.** Refer to Chapter 7, “Post-Repair Procedures,” for further information on the calibration and performance verification tests required after the assembly has been replaced.



---

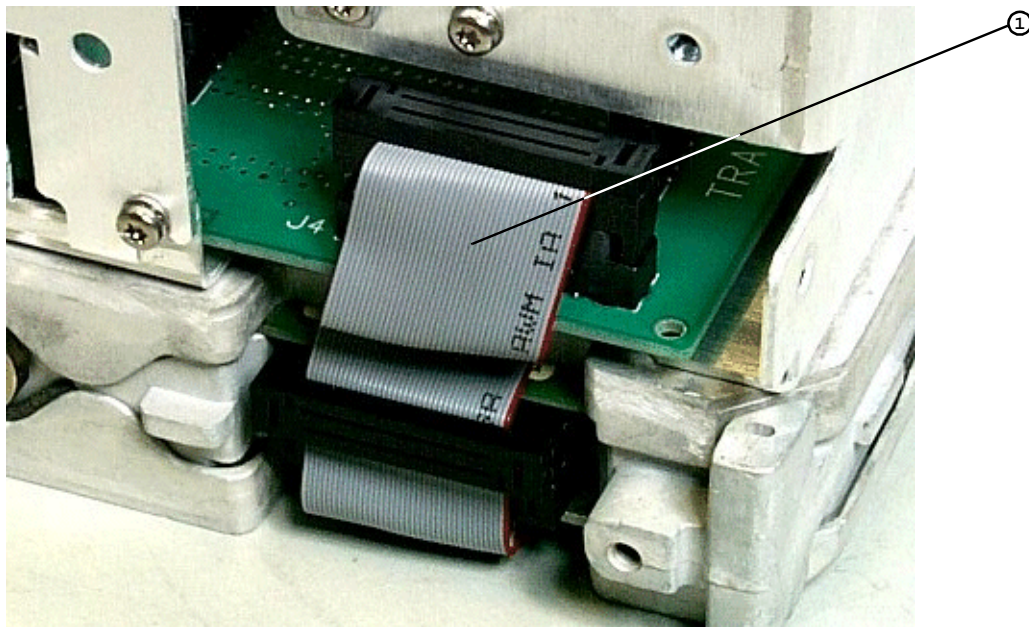
## A8 RF Assembly

**CAUTION** Use ESD precautions when performing this replacement procedure.

### Removal

- Step 1.** Remove instrument outer case. Refer to the removal procedure “Instrument Outer Case” on page 149
- Step 2.** Remove the instrument chassis cover. Refer to the removal procedure “Chassis Cover” on page 153.
- Step 3.** Remove the A1 front frame assembly. Refer to the removal procedure “A1 Front Frame Assembly” on page 155.

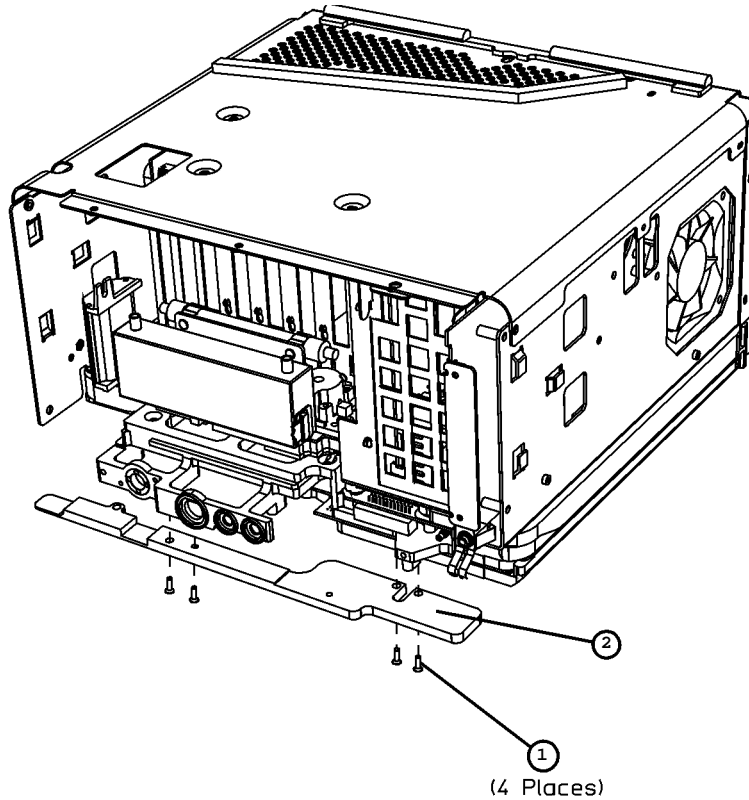
**Figure 6-35** RF Assembly Ribbon Cable



- Step 4.** Referring to Figure 6-36. Remove the 4 screws (1) and the shock spreader assembly bar (2).

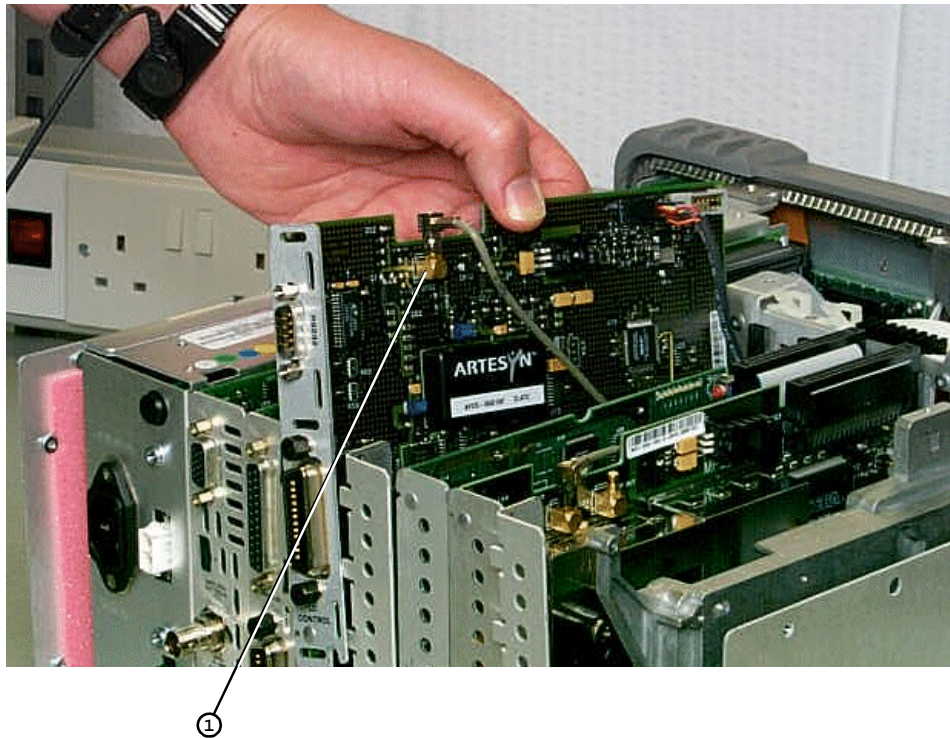
Figure 6-36

Shock Spreader Bar



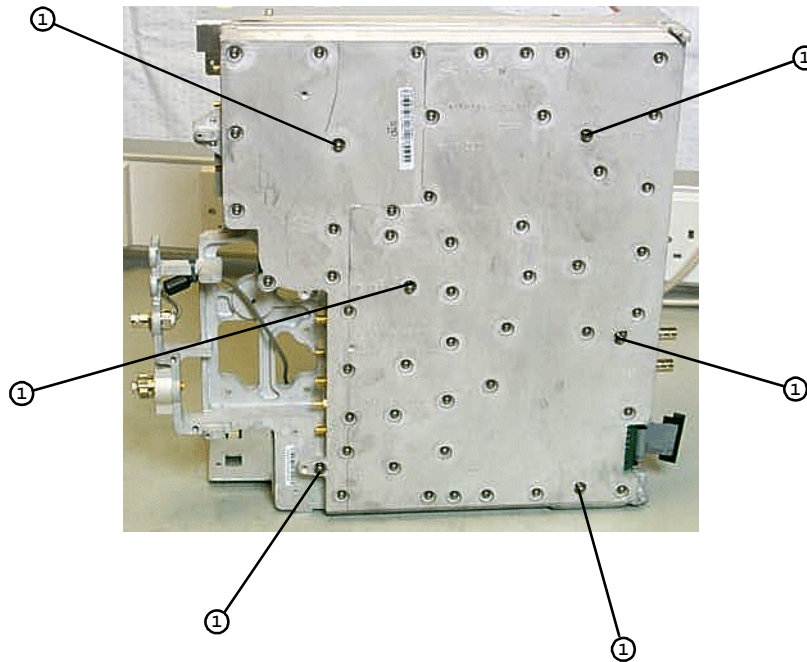
- Step 5.** Disconnect the ribbon cable W4 (1) from the rear of the A8 RF assembly, shown in Figure 6-35, and the ribbon cable W5 from the front of the assembly.
- Step 6.** Refer to Figure 6-37. Disconnect the coaxial cable W33 (1) from the SIB (A7A2) assembly.

Figure 6-37 SIB Noise Source Cable



- Step 7.** On models N8974A and N8975A, disconnect the ribbon cable W16 from the Frequency Extension (A7A3) assembly.
- Step 8.** Disconnect the 2 semi-rigid cables W13 and W8, and 1 coax cable W15 from the front end (A2) assembly. Refer to the “A2 RF Front End” on page 179.
- Step 9.** On models N8974A and N8975A, disconnect the 3 semi-rigid cables W6, W7, and W14 from the microwave front end (A3) assembly. Refer to the “A3 Microwave Front End Assembly” on page 177.
- Step 10.** Disconnect the coaxial cable W31 from the A8P5 connector on the RF Assembly (A8).
- Step 11.** Referring to Figure 6-38, position the instrument upside down and remove the 6 screws (1) marked “RF Deck” securing the RF assembly (A8) to the chassis.

Figure 6-38 A8 RF Assembly



**Step 12.** Carefully lift the RF assembly from the chassis.

---

**CAUTION**

The cables and assemblies are easily damaged. Once removed, it is best to lay the RF assembly flat on a work surface. Do not rest it against any of the RF assemblies or cables.

---

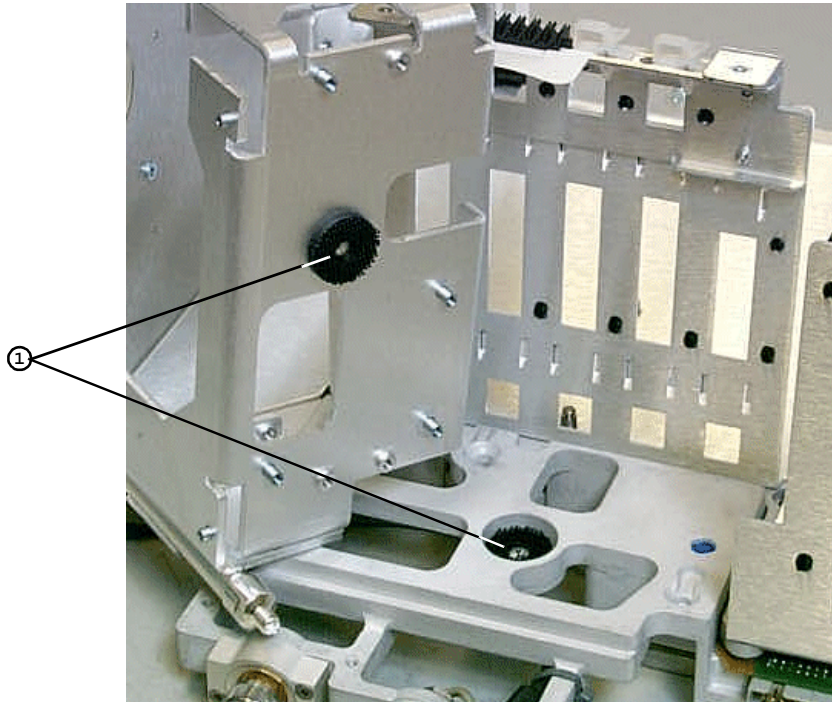
- Step 13.** On models N8974A and N8975A, remove the A8A4 LOIS assembly and all connections. Refer to the removal procedure “A8A4 LO Amp/IF Switch Assembly” on page 203.
- Step 14.** On models N8974A and N8975A, remove the A8A6 YIG and all connections. Refer to the removal procedure “A8A6 YIG-Tuned Filter/Mixer” on page 204.
- Step 15.** Remove the A8FL1 low pass filter and W12 from the A8A5 input attenuator.
- Step 16.** Remove the A8A5 input attenuator and all connections. Refer to the removal procedure “A8A5 Input Attenuator” on page 207.
- Step 17.** Replace the A8MP4 metal bracket, ensure the W5 ribbon cable goes underneath this bracket and is connected to the A8P4 connector on the A8 RF assembly.
- Step 18.** Remove the A8A2 second Converter and all connections. Refer to the removal procedure “A8A2 Second Converter” on page 209.
- Step 19.** Remove the 4 screws holding on the A8MP2 metal bracket.
- Step 20.** Pull the bracket to separate it for the A8 Assembly.



## Replacement

**Step 1.** Position the A8MP2 metal bracket such that the two adhesive materials link.

**Figure 6-39** Adhesive Material Location



**Step 2.** Replace the 4 screws holding on the A8MP2 metal bracket.

**Step 3.** Replace the A8A2 Second Converter and all connections. Refer to the replacement procedure “A8A2 Second Converter” on page 209.

**Step 4.** Replace the A8MP4 (metal bracket), ensure the W5 ribbon cable is below this bracket and is connected to the A8P4 connector on the A8 RF assembly.

**Step 5.** Replace the A8A5 input attenuator and all connections. Refer to the replacement procedure “A8A5 Input Attenuator” on page 207.

**Step 6.** Replace the A8FL1 low pass filter and W12 to the A8A5 input attenuator.

**Step 7.** Replace the A8A6 YIG and all connections. Refer to the replacement procedure “A8A6 YIG-Tuned Filter/Mixer” on page 204.

**Step 8.** Replace the A8A4 LOIS and all connections. Refer to the replacement procedure “A8A4 LO Amp/IF Switch Assembly” on page 203.

## Replacing Assemblies

### A8 RF Assembly

- Step 9.** Position the A8 RF assembly resting on the work surface, and lower the card cage assembly onto the RF assembly taking care not to pinch any cables.
- Step 10.** Referring to Figure 6-38, replace the 6 screws (1) securing the RF assembly to the chassis, tighten them to 9 inch-pounds.
- Step 11.** Reconnect the coaxial cable W31 to the A8P5 connector on the RF Assembly.
- Step 12.** On models N8974A and N8975A, reconnect the 3 semi-rigid cables W6, W7, and W14 to the microwave front end (A3) assembly. Refer to the “A3 Microwave Front End Assembly” on page 177.
- Step 13.** Reconnect the 2 semi-rigid cables W13 and W8, and 1 coax cable W15 to the front end (A2) assembly. Refer to the “A2 RF Front End” on page 179.
- Step 14.** On models N8974A and N8975A, reconnect the W16 ribbon cable to A7A3 frequency extension assembly and the A8A6 YIG and the A8A4 LOIS.
- Step 15.** Refer to Figure 6-36. Replace the shock spreader assembly bar (2), and tighten the 4 screws. (1) to 9 inch-pounds.
- Step 16.** Refer to Figure 6-37. Reconnect the coaxial cable W33 (1) to the SIB A7A2 assembly.
- Step 17.** Reconnect the ribbon cable W4 (1) from the rear of the A8 RF assembly, shown in Figure 6-35, and the ribbon cable W5 to the front of the assembly.
- Step 18.** Replace the A1 front frame assembly. Refer to the replacement procedure “A1 Front Frame Assembly” on page 155.
- Step 19.** Replace the instrument chassis cover. Refer to the replacement procedure “Chassis Cover” on page 153.
- Step 20.** Replace instrument outer case. Refer to the replacement procedure “Instrument Outer Case” on page 149.
- Step 21.** Refer to Chapter 7, “Post-Repair Procedures,” for further information on the calibration and performance verification tests required after the assembly has been replaced.

## A8 Sub-assemblies

### A8A4 LO Amp/IF Switch Assembly

(N8974A and N8975A)

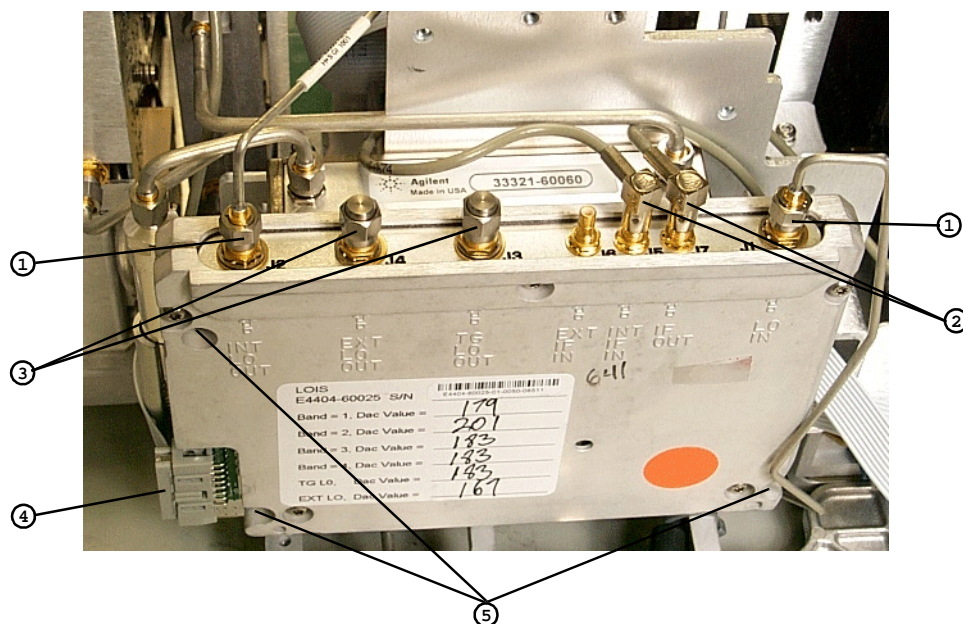
**CAUTION** Use ESD precautions when performing this replacement procedure.

**NOTE** The LO amplifier and IF switch (LOIS) assembly can be removed without removing the RF assembly.

#### Removal

- Step 1.** Remove the instrument chassis cover. Refer to the removal procedure “Chassis Cover” on page 153.
- Step 2.** Remove the A1 front frame assembly. Refer to the removal procedure “A1 Front Frame Assembly” on page 155.
- Step 3.** Referring to Figure 6-40, disconnect the 2 semi-rigid cables W24 and W23 (1) and the 2 Flexible coaxial cables W20 and W21 (2) from the A8A4 assembly.
- Step 4.** Referring to Figure 6-40, disconnect the 50 ohm loads (3) from the J3 and J4 connectors on the A8A4 assembly.
- Step 5.** Disconnect the frequency extension ribbon cable W16 (4).
- Step 6.** Remove the 3 screws (5) and remove the A8A4 assembly.

**Figure 6-40** Removing the LO Amplifier/IF Switch Assembly



Replacing Assemblies  
**A8 Sub-assemblies**

**Replacement**

---

**CAUTION** Use care not to pinch any cables during reassembly.

---

- Step 1.** Referring to Figure 6-40, replace the A8A4 assembly and secure with the 3 screws (5). Tighten them to 9 inch-pounds.
- Step 2.** Reconnect the frequency extension ribbon cable W16 (4).
- Step 3.** Referring to Figure 6-40, reconnect the 50 ohm loads (3) to the J3 and J4 connectors on the A8A4 assembly. Torque the SMA connectors to 8 inch-pounds.
- Step 4.** Referring to Figure 6-40, reconnect the 2 flexible coaxial cables W20 and W21 (2) and the 2 semi-rigid cables W24 and W23 (1) to the A8A4 assembly. Torque the 2 semi-rigid cables connectors to 5 inch-pounds.
- Step 5.** Replace the A1 front frame assembly. Refer to the replacement procedure “A1 Front Frame Assembly” on page 155.
- Step 6.** Replace the instrument chassis cover. Refer to the replacement procedure “Chassis Cover” on page 153.
- Step 7.** Refer to Chapter 7, “Post-Repair Procedures,” for further information on the calibration and performance verification tests required after the assembly has been replaced.

**A8A6 YIG-Tuned Filter/Mixer**

(N8974A and N8975A)

---

**CAUTION** Use ESD precautions when performing this replacement procedure.

---

---

**NOTE** The YIG-Tuned filter/mixer assembly can be removed without removing the RF assembly.

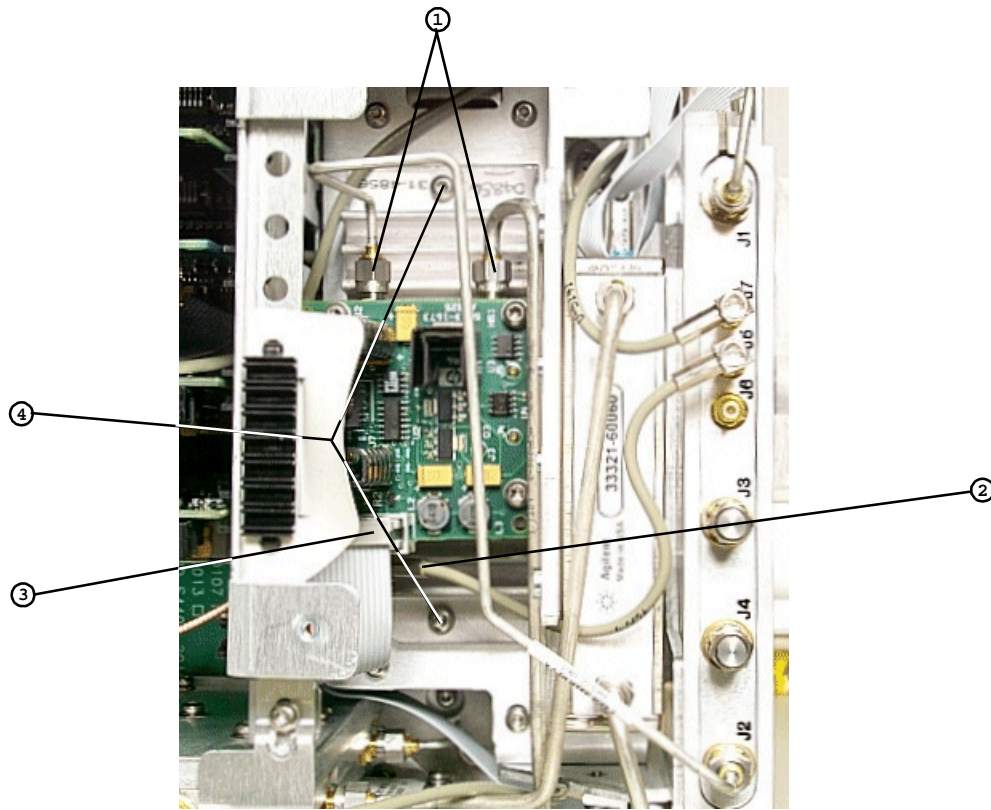
---

**Removal**

- Step 1.** Remove the instrument chassis cover. Refer to the removal procedure “Chassis Cover” on page 153.
- Step 2.** Extend the A1 front frame assembly. Refer to the removal procedure “Extension of the Front Frame Assembly” on page 155.
- Step 3.** Referring to Figure 6-41, disconnect the 2 semi-rigid cables W14 and W24 (1) and the flexible coaxial cable W20 (2) from the A8A6 assembly.
- Step 4.** Referring to Figure 6-41, disconnect the frequency extension ribbon cable W16 (3).
- Step 5.** Referring to Figure 6-41, remove the 2 screws (4) from the assembly bracket.

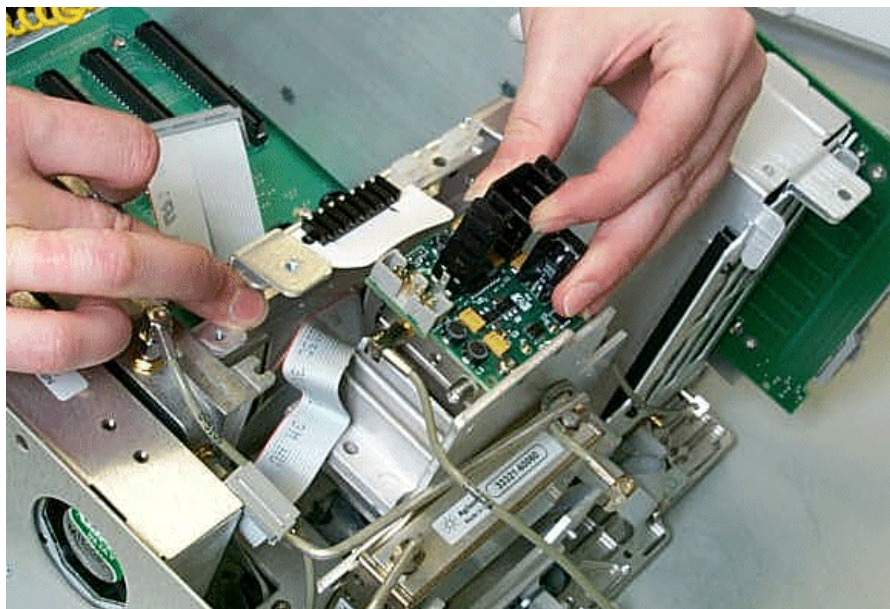


**Figure 6-41** YIG Tuned Mixer Cables and Screw Locations



**Step 6.** Pull on the card cage to aid the removal of the A8A6 assembly from the assembly bracket, as shown in Figure 6-42.

**Figure 6-42** YIG Tuned Mixer Removal



**Replacement**

---

**CAUTION**

---

Do not to overtighten the SMA connections to the YIG-tuned filter/mixer assembly. If the connectors are broken loose, the assembly must be returned to the factory for repair.

- Step 1.** Refer to Figure 6-42. Replace the A8A6 YIG-tuned filter/mixer assembly onto the assembly bracket.
- Step 2.** Referring to Figure 6-41, replace the 2 screws (**4**) to the assembly bracket, tighten them to 9 inch-pounds.
- Step 3.** Reconnect the frequency extension ribbon cable W16 (**3**).
- Step 4.** Reconnect the flexible coaxial cable W20 (**2**) to the A8A6 assembly.
- Step 5.** Referring to Figure 6-41, reconnect the 2 semi-rigid cables W14 and W24 (**1**) and tighten them to 8 inch-pounds with a 5/16" wrench
- Step 6.** Replace the A1 front frame assembly. Refer to the replacement procedure "A1 Front Frame Assembly" on page 155.
- Step 7.** Replace the instrument chassis cover. Refer to the replacement procedure "Chassis Cover" on page 153.
- Step 8.** Align the YTF using the procedure described in "Align YTF" on page 21.
- Step 9.** Refer to Chapter 7, "Post-Repair Procedures," for further information on the calibration and performance verification tests required after the assembly has been replaced.

## A8A5 Input Attenuator

---

**CAUTION**

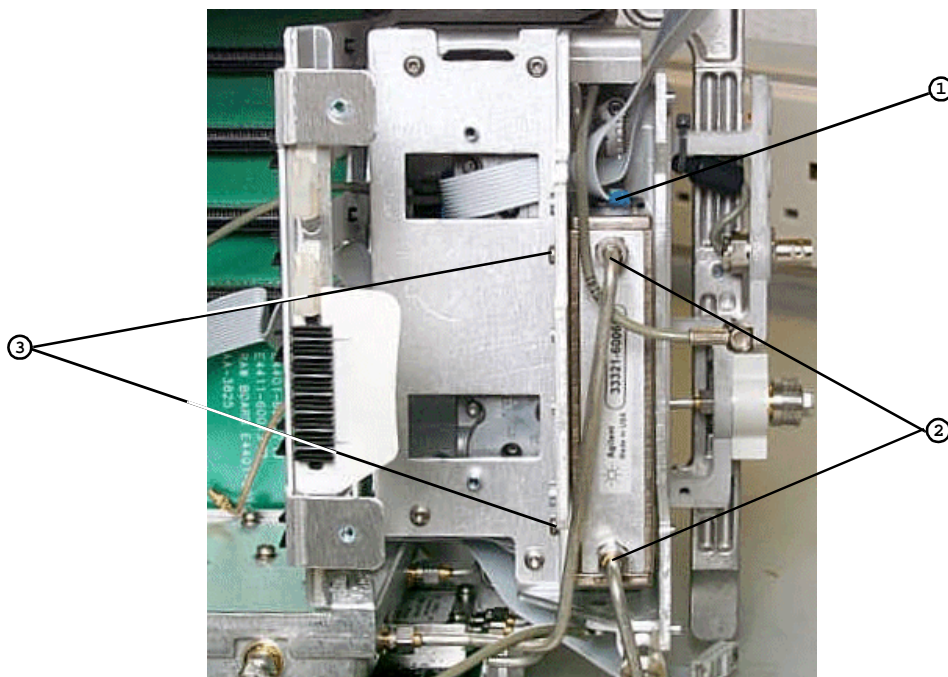
---

Use ESD precautions when performing this replacement procedure.

### Removal

- Step 1.** Remove the instrument chassis cover. Refer to the removal procedure “Chassis Cover” on page 153.
- Step 2.** Remove the A1 front frame assembly. Refer to the removal procedure “A1 Front Frame Assembly” on page 155.
- Step 3.** On models N8974A and N8975A, remove the A8A4 LO amplifier and IF switch (LOIS) assembly. Refer to the removal procedure “A8A4 LO Amp/IF Switch Assembly” on page 203.
- Step 4.** On models N8974A and N8975A, remove the A8A6 YIG-Tuned filter/mixer assembly. Refer to the removal procedure “A8A6 YIG-Tuned Filter/Mixer” on page 204.
- Step 5.** Refer to Figure 6-43. Disconnect the ribbon cable W5 ( **1** ) from the A8A5 input attenuator.
- Step 6.** Refer to Figure 6-43. Disconnect the 2 semi-rigid cables W12 and W13 ( **2** ) from the A8A5 input attenuator.
- Step 7.** Referring to Figure 6-43, remove the 2 screws ( **4** ) from the assembly bracket.
- Step 8.** Remove the A8A5 assembly.

**Figure 6-43**      **Input Attenuator Hardware**



Replacing Assemblies  
**A8 Sub-assemblies**

**Replacement**

---

**CAUTION**

Use care not to pinch any cables during reassembly.

- Step 1.** Replace the A8A5 assembly.
- Step 2.** Referring to Figure 6-43, align the A8A5 assembly with the screw holes on the assembly bracket, and replace the 2 screws ( **3** ). Tighten them to 9 inch-pounds.
- Step 3.** Refer to Figure 6-43. Reconnect the 2 semi-rigid cables W12 and W13 ( **2** ) to the A8A5 attenuator. Torque to 5 inch-pounds.
- Step 4.** Refer to Figure 6-43. Reconnect the ribbon cable W5 ( **1** ) to the A8A5 attenuator.
- Step 5.** On models N8974A and N8975A, replace the A8A6 YIG-Tuned filter/mixer assembly. Refer to the replacement procedure “A8A6 YIG-Tuned Filter/Mixer” on page 204.
- Step 6.** On models N8974A and N8975A, replace the A8A4 LO amplifier and IF switch (LOIS) assembly. Refer to the replacement procedure “A8A4 LO Amp/IF Switch Assembly” on page 203.
- Step 7.** Replace the instrument chassis cover. Refer to the replacement procedure “Chassis Cover” on page 153.
- Step 8.** Replace the A1 front frame assembly. Refer to the replacement procedure “A1 Front Frame Assembly” on page 155.
- Step 9.** On models N8974A and N8975A, align the YTF using the procedure described in “Align YTF” on page 21.
- Step 10.** Refer to Chapter 7, “Post-Repair Procedures,” for further information on the calibration and performance verification tests required after the assembly has been replaced.

## A8A2 Second Converter

---

**CAUTION**

---

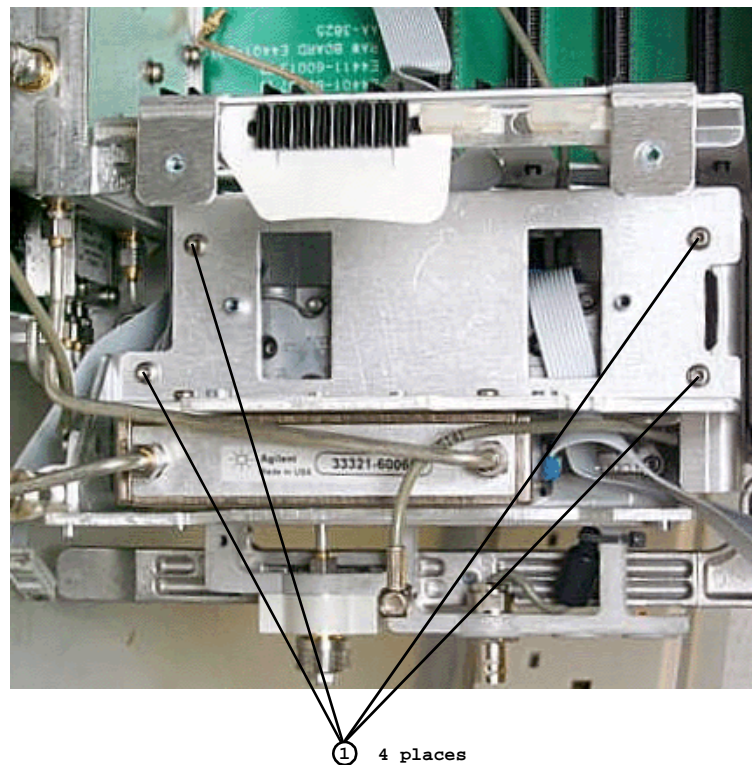
Use ESD precautions when performing this replacement procedure.

### Removal

- Step 1.** Remove the instrument chassis cover. Refer to the removal procedure “Chassis Cover” on page 153.
- Step 2.** Remove the A1 front frame assembly. Refer to the removal procedure “A1 Front Frame Assembly” on page 155.
- Step 3.** On models N8974A and N8975A, remove the A8A4 LO amplifier and IF switch (LOIS) assembly. Refer to the removal procedure “A8A4 LO Amp/IF Switch Assembly” on page 203.
- Step 4.** On models N8974A and N8975A, remove the A8A6 YIG-Tuned filter/mixer assembly. Refer to the removal procedure “A8A6 YIG-Tuned Filter/Mixer” on page 204.
- Step 5.** Remove the A8A5 input attenuator assembly. Refer to the removal procedure “A8A5 Input Attenuator” on page 207.
- Step 6.** Refer to Figure 6-44, remove the 4 screws (1) from the assembly bracket and remove the bracket.

**Figure 6-44**

**Position of Screws Securing Assembly Bracket**

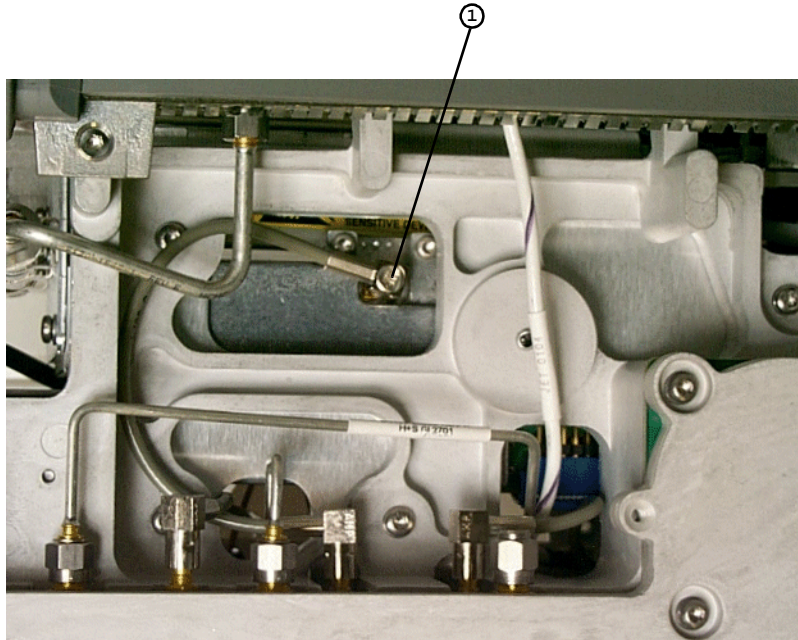




Replacing Assemblies  
**A8 Sub-assemblies**

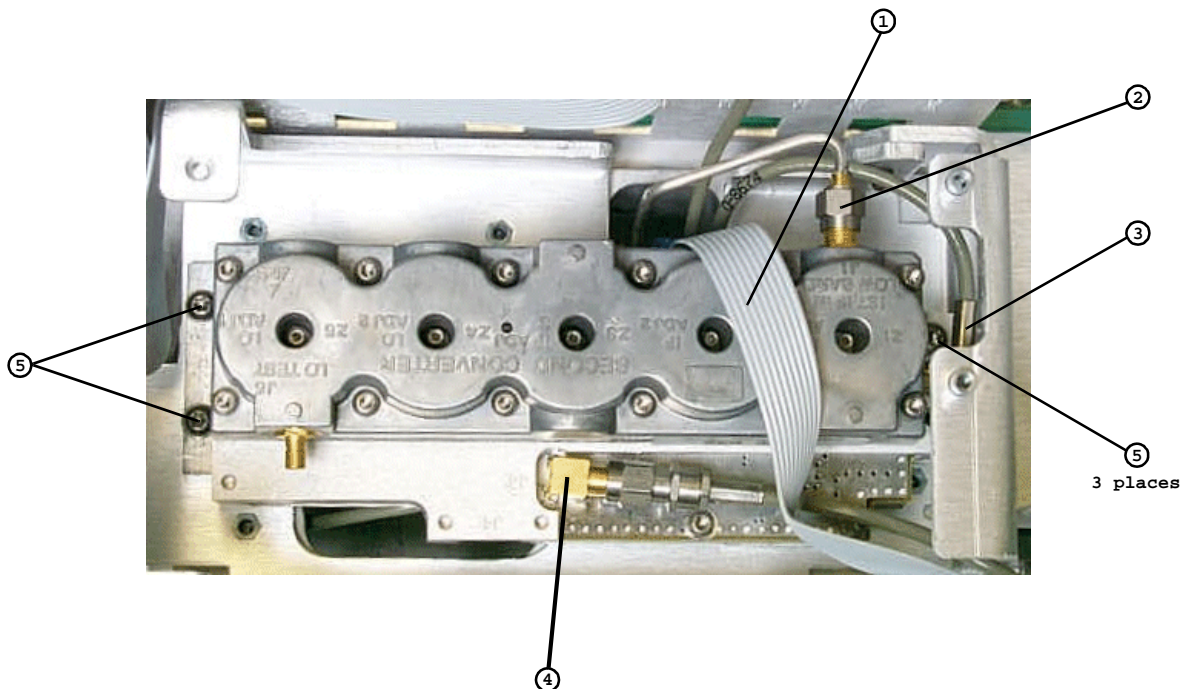
**Step 7.** Refer to Figure 6-45 viewing the bottom side of the NFA, disconnect the flexible coaxial cable W10 (1) from the A8A2 J4 connector.

**Figure 6-45**      **Second Converter, Bottom View**



**Step 8.** Refer to Figure 6-46. Disconnect the ribbon cable W5 (1) from the A8A2 second converter.

**Figure 6-46**      **Second Converter Hardware**



- Step 9.** Refer to Figure 6-46. Disconnect the semi-rigid cable W9 (2) from the A8A2 J1 connector.
- Step 10.** Refer to Figure 6-46. Disconnect the flexible coaxial cable W11 (3) from the A8A2 J2 connector.
- Step 11.** On models N8974A and N8975A and referring to Figure 6-46. Disconnect the SMA connector W21 (4) from the A8A2 J3 connector.
- Step 12.** Referring to Figure 6-46, remove the 3 screws (5) from the assembly bracket.
- Step 13.** Remove the A8A2 second converter assembly.

### **Replacement**

- Step 1.** Refer to Figure 6-46. Install the second converter assembly with a single screw (5), but do not fully tighten.

---

**NOTE**

---

The screws that secure the second converter in place are longer than the other assembly screws.

- Step 2.** Install the other 2 screws (5), and tighten all 3 screws to 9 inch-pounds.
- Step 3.** On models N8974A and N8975A and referring to Figure 6-46. Reconnect the SMA connector W21 (4) to the A8A2 J3 connector.
- Step 4.** Refer to Figure 6-46. Reconnect the flexible coaxial cable W11 (3) to the A8A2 J2 connector.
- Step 5.** Refer to Figure 6-46. Reconnect the semi-rigid cable W9 (2) to the A8A2 J1 connector. Torque to 5 inch-pounds.
- Step 6.** Refer to Figure 6-46. Reconnect the ribbon cable W5 (1) to the A8A2 second converter.
- Step 7.** Refer to Figure 6-45 viewing the bottom side of the NFA, reconnect the flexible coaxial cable W10 (1) to the A8A2 J4 connector.
- Step 8.** Refer to Figure 6-44. Replace the sub-bracket to the microcircuit bracket and replace the 4 screws (1) to secure the assembly bracket. Tighten them to 9 inch-pounds.
- Step 9.** Replace the A8A5 attenuator assembly. Refer to the replacement procedure “A8A5 Input Attenuator” on page 207.
- Step 10.** On models N8974A and N8975A, replace the A8A6 YIG-Tuned filter/mixer assembly. Refer to the replacement procedure “A8A6 YIG-Tuned Filter/Mixer” on page 204.
- Step 11.** On models N8974A and N8975A, replace the A8A4 LO amplifier and IF switch (LOIS) assembly. Refer to the replacement procedure “A8A4 LO Amp/IF Switch Assembly” on page 203.

**A8 Sub-assemblies**

- Step 12.** Replace the A1 front frame assembly. Refer to the replacement procedure “A1 Front Frame Assembly” on page 155.
- Step 13.** Replace the instrument chassis cover. Refer to the replacement procedure “Chassis Cover” on page 153.
- Step 14.** On models N8974A and N8975A, align the YTF using the procedure described in “Align YTF” on page 21.
- Step 15.** Refer to Chapter 7, “Post-Repair Procedures,” for further information on the calibration and performance verification tests required after the assembly has been replaced.



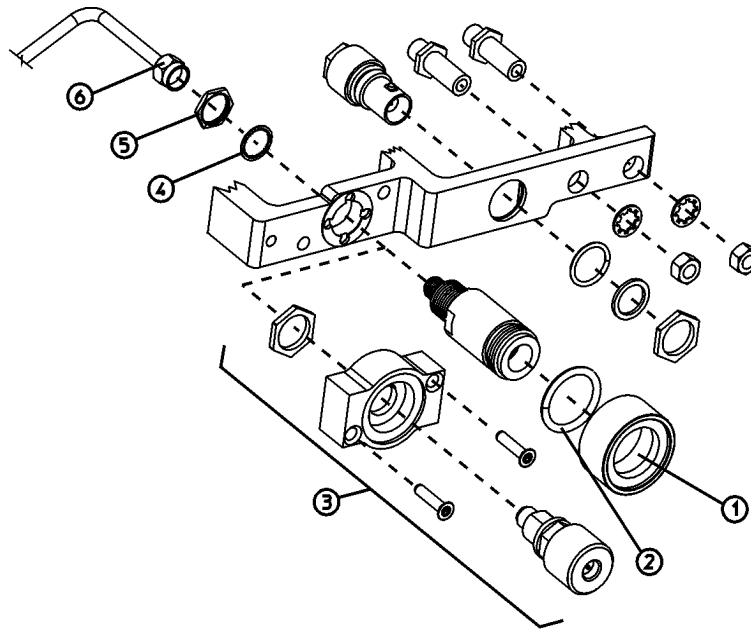
## Input Connector

**CAUTION** Use ESD precautions when performing this replacement procedure.

### Removal

- Step 1.** Remove the instrument chassis cover. Refer to the removal procedure “Chassis Cover” on page 153.
- Step 2.** Remove the A1 front frame assembly. Refer to the removal procedure “A1 Front Frame Assembly” on page 155.
- Step 3.** Remove the RF connector. For a Type-N connector, refer to the removal procedure “Type-N Connector” on page 213. For a APC 3.5, refer to the removal procedure “APC 3.5 Connector” on page 214.

**Figure 6-47** RF Connector, Type-N and APC 3.5



sl797b

### Type-N Connector

(N8972A and N8973A)

1. Refer to Figure 6-47. Gently twist the water seal (1) and remove it from around the input connector. Make sure the O-ring (2) is retained within the water seal.
2. Use a 5/16” wrench to remove the semi-rigid (6) cable from the input connector.
3. Loosen the nut (5) from the back side of the input connector with a 9/16” wrench, and gently remove the connector, retaining the washer (4) and nut.

Replacing Assemblies  
**A8 Sub-assemblies**

**APC 3.5 Connector**

(N8974A and N8975A)

1. Refer to Figure 6-47. Use a 5/16" wrench to remove the semi-rigid (6) cable from the input connector.
2. Remove the 2 screws that fasten the APC 3.5 connector assembly (3) to the frame.
3. Remove the connector assembly.

**Replacement**

- Step 1.** Install the RF connector. For a Type-N connector, refer to the replacement procedure "Type-N Connector" on page 213. For a APC 3.5, refer to the replacement procedure "APC 3.5 Connector" on page 214.

**Type-N Connector**

1. Refer to Figure 6-47. Reattach the input connector and secure with the washer (5), and nut (4). Tighten the nut to 21 inch-pounds.
2. Reattach the semi-rigid cable (6) to the input connector with a 5/16" wrench. Tighten it to 10 inch-pounds.
3. Make sure the O-ring (2) is still inside the water seal (1), then gently twist and push the water seal onto the input connector.
4. Continue with step 2 below.

**APC 3.5 Connector**

1. Refer to Figure 6-47. Reattach the APC 3.5 input connector assembly (2) and secure with the 2 screws. Tighten them to 9 inch-pounds.
2. Reattach the semi-rigid cable (6) to the input connector with a 5/16" wrench. Tighten it to 10 inch-pounds.
3. Continue with step 2 below.

- Step 2.** Reconnect the A1 front frame to the chassis. Refer to the replacement procedure "A1 Front Frame Assembly" on page 155.

- Step 3.** Replace the chassis cover. Refer to the replacement procedure "Chassis Cover" on page 153.

- Step 4.** Replace the outer case. Refer to the replacement procedure "Instrument Outer Case" on page 149.

- Step 5.** Refer to Chapter 7, "Post-Repair Procedures," for further information on the calibration and performance verification tests required after the assembly has been replaced.

---

---

# **7 Post-Repair Procedures**

## **What You Will Find in This Chapter**

The post repair and calibration and performance verification tests in this chapter must be performed if there is an assembly has been replaced. The 10.0 MHz adjustment should be performed if the NFA fails the 10.0 MHz performance test.

---

### **NOTE**

Familiarize yourself with the safety symbols marked on the noise figure analyzer and read the general safety considerations and the safety note definitions in the front of this guide, *before* you begin the procedures in this chapter.

There is also an overview of the N2716A Performance Software.

---

## Before You Start

There are three things you should do before starting the post-repair procedures and the calibration and performance verification procedure:

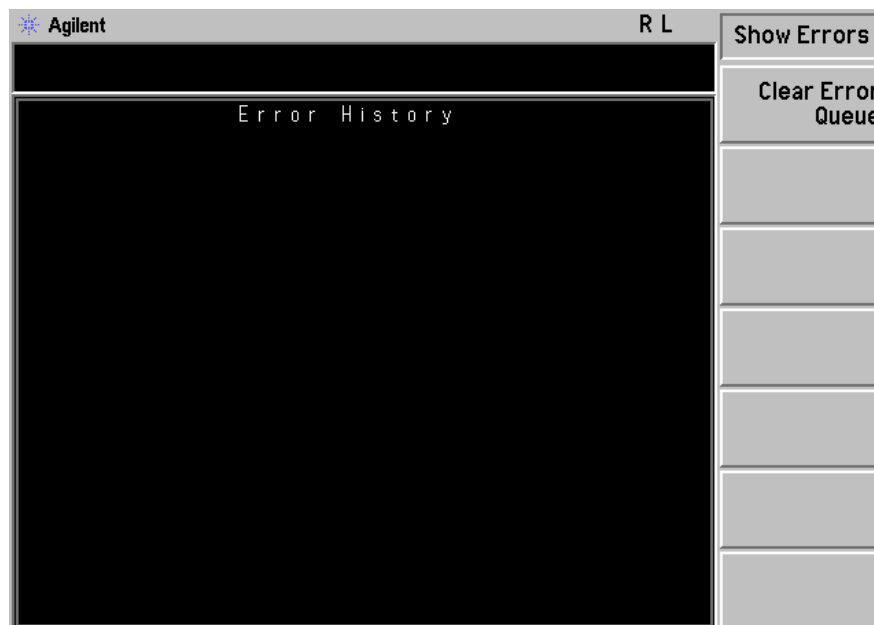
- Check that you are familiar with the safety symbols marked on the noise figure analyzer and read the general safety considerations and the symbol definitions given in the front of this service guide.
- Check that the noise figure analyzer has been turned on and allowed to warm up for at least 30 minutes at room temperature before making any performance verification. The noise figure analyzer *must* be allowed to stand at room temperature at least 2 hours prior to the 30 minute warm-up.
- Read the rest of this section.

## Post-Repair Procedure

- Step 1.** Power up the repaired NFA.
- Step 2.** Check it passes the self-test. See “Bootrom Self-Test Check” on page 24.
- Step 3.** Ensure there are no error messages annotated in the display status line.
- Step 4.** Check there are no errors in the error queue, as shown in Figure 7-1.

Figure 7-1

Example of an Error Queue without any Errors Displayed



- Step 5.** Set the instrument to its **Full Span**. (This menu key is found under the **Frequency** key.)

Post-Repair Procedures  
**Before You Start**

- Step 6.** Enter the noise source ENR Table data.
- Step 7.** Connect the Noise Source to the Input.
- Step 8.** Calibrate the NFA across the Full Span.
- Step 9.** If it performs the post-repair procedures correctly then run all the calibration and performance verification checks located in the *Calibration and Performance Verification Guide* for your noise figure analyzer or use the N2716A Performance Verification Software. The tests are listed in the “Performance Verification and Adjustment Procedures” section.

## Performance Verification and Adjustment Procedures

### Performance Verification Procedures

The NFA performance verification consists of the tests shown in Table 7-1. You must run all these tests to verify the instrument's performance.

**Table 7-1**      **List of Performance Verification Tests**

Test no.	Performance Verification Test
1	10 MHz Out Frequency Reference Accuracy <sup>a</sup>
2	Input VSWR
3	Frequency Accuracy
4	Noise Source Supply Accuracy
5	Noise Figure Range & Accuracy
6	Gain Measurement Uncertainty
7	Instrument Noise Figure
8	Measurement Jitter

a. If the 10.0 MHz Out Frequency Reference Accuracy performance verification test fails, perform the calibration adjustment listed in Table 7-2.

### Adjustment Procedures

The 10.0 MHz Out Frequency Reference can be adjusted using the procedure described in the *Calibration and Performance Verification Guide*.

**Table 7-2**      **Adjustment**

Adjustment no.	Calibration Adjustments
1	10 MHz Out Frequency Reference Adjustment

**NOTE**      No other user adjustment is possible.

## Agilent N2716A Performance Verification Software

This section provides a brief description of performance verification and a list of the tests supported by the performance verification software.

---

### NOTE

For additional information on Performance Verification tests, refer to the on-line help on the *Agilent N2716A Performance Verification Software* or the *N2716A Getting Started Guide*.

---

### Test Environment

Agilent Test Management Environment is the new high performance, 32 bit, component-based calibration platform from Agilent Technologies, Inc. Agilent Test Management Environment can be expanded by purchasing test packages to test additional Agilent instruments. Agilent Test Management Environment reduces the cost of instrument maintenance by providing quick and accurate automated tests—reducing instrument downtime—and providing a “common look and feel”—reducing operator training.

### Performance Verification Tests

Performance verification tests are tests designed to provide the highest level of confidence that the instrument being tested conforms to published, factory-set specifications. The tests are supplied in an automated test software package. The automatic execution of the full set of performance tests will take between two and three hours to complete. Performance tests are designed to test an instrument operating within the operational temperature range defined by the instrument specifications. Some repairs require a performance test to be run after the repair.

If the instrument is unable to pass any of the performance tests or adjustment tests, further repairs are needed.

The *Agilent N2716A Performance Verification Software* is sold as a separate product that compliments the Agilent NFA products. For ordering information get in touch with your local Agilent sales and service office listed in “*Contacting Agilent Technologies, Inc.*” on page 140.