



**Advanced Test Equipment Rentals**  
**www.atecorp.com 800-404-ATEC (2832)**

**FLUKE®**

**1520**  
MegOhmMeter

Calibration Manual

### Limited Warranty & Limitation of Liability

Each Fluke product is warranted to be free from defects in material and workmanship under normal use and service. The warranty period is three years and begins on the date of shipment. Parts, product repairs and services are warranted for 90 days. This warranty extends only to the original buyer or end-user customer of a Fluke authorized reseller, and does not apply to fuses, disposable batteries or to any product which, in Fluke's opinion, has been misused, altered, neglected, contaminated, or damaged by accident or abnormal conditions of operation or handling. Fluke warrants that software will operate substantially in accordance with its functional specifications for 90 days and that it has been properly recorded on non-defective media.

Fluke authorized resellers shall extend this warranty on new and unused products to end-user customers only but have no authority to extend a greater or different warranty on behalf of Fluke. Warranty support is available if product is purchased through a Fluke authorized sales outlet or Buyer has paid the applicable international price. Fluke reserves the right to invoice Buyer for importation costs of repair/replacement parts when product purchased in one country is submitted for repair in another country.

Fluke's warranty obligation is limited, at Fluke's option, to refund of the purchase price, free of charge repair, or replacement of a defective product which is returned to a Fluke authorized service center within the warranty period. To obtain warranty service, contact your nearest Fluke authorized service center to obtain return authorization information, then send the product to that service center, with a description of the difficulty, postage and insurance prepaid (FOB Destination), to the nearest Fluke authorized service center. Fluke assumes no risk for damage in transit. Following warranty repair, the product will be returned to Buyer, transportation prepaid (FOB Destination). If Fluke determines that the failure was caused by neglect, misuse, contamination, alteration, accident or abnormal condition of operation or handling, including overvoltage failures caused by use outside of the product's specified rating, or normal wear and tear of mechanical components, Fluke will provide an estimate of repair costs and obtain authorization before commencing the work. Following repair, the product will be returned to the Buyer transportation prepaid and the Buyer will be billed for the repair and return transportation charges (FOB Shipping Point).

THIS WARRANTY IS BUYER'S SOLE AND EXCLUSIVE REMEDY AND IS IN LIEU OF ALL OTHER WARRANTIES, EXPRESS OR IMPLIED, INCLUDING BUT NOT LIMITED TO ANY IMPLIED WARRANTY OF MERCHANTABILITY OR FITNESS FOR A PARTICULAR PURPOSE. FLUKE SHALL NOT BE LIABLE FOR ANY SPECIAL, INDIRECT, INCIDENTAL OR CONSEQUENTIAL DAMAGES OR LOSSES, INCLUDING LOSS OF DATA, ARISING FROM ANY CAUSE OR THEORY.

Since some countries or states do not allow limitation of the term of an implied warranty, or exclusion or limitation of incidental or consequential damages, the limitations and exclusions of this warranty may not apply to every buyer. If any provision of this Warranty is held invalid or unenforceable by a court or other decision-maker of competent jurisdiction, such holding will not affect the validity or enforceability of any other provision.

Fluke Corporation  
P.O. Box 9090  
Everett, WA 98206-9090  
U.S.A.

Fluke Europe B.V.  
P.O. Box 1186  
5602 BD Eindhoven  
The Netherlands

# Table of Contents

Title	Page
Introduction.....	1
Contacting Fluke.....	2
Precautions and Safety Information.....	2
International Symbols.....	2
Specifications.....	4
Required Equipment.....	6
Performance Test.....	7
Display Test.....	7
Backlight Test.....	8
Battery Test.....	8
Discharge Circuit Test.....	8
Volts and Ohms Measurement Accuracy Verification.....	8
LO Ohms Measurement Accuracy Verification.....	9
Meg Ohm Measurement Accuracy Verification.....	9
Meg Ohm Voltage Source Accuracy Verification.....	11
Maintaining the Meter.....	12
Cleaning.....	12
Replacing and Disposing of the Batteries.....	12
Testing and Replacing the Fuse.....	13
Replacement Parts and Optional Accessories.....	15



# ***List of Tables***

<b>Table</b>	<b>Title</b>	<b>Page</b>
1.	International Symbols .....	2
2.	Required Equipment.....	6
3.	Display Icons.....	7
4.	Volts and Ohms Test.....	8
5.	Lo Ohms Test.....	9
6.	Meg Ohm Test.....	10
7.	Meg Ohm Voltage Source Test.....	11



# ***List of Figures***

<b>Figure</b>	<b>Title</b>	<b>Page</b>
1.	Display .....	7
2.	Replacing the Batteries.....	13
3.	Replacing the Fuse .....	14





## **Introduction**

### **⚠ Warning**

**To avoid shock or injury, do not perform the verification tests or calibration procedures described in this manual unless you are qualified to do so.**

**The information provided in this document is for the use of qualified personnel only.**

### **Caution**

**The 1520 MegOhmMeter contains parts that can be damaged by static discharge.**

**Follow the standard practices for handling static sensitive devices.**

The information in this manual deals with the Fluke 1520 MegOhmMeter, (hereafter referred to as “the Meter”). Information provided includes:

- Precautions and safety information
- Specifications
- Basic maintenance (cleaning, replacing the battery and fuses)
- Performance test procedures
- Accessories and replaceable parts

For complete operating instructions, refer to the *1520 Users Manual* PN 1543203.

## Contacting Fluke

To order accessories, receive assistance, or locate the nearest Fluke distributor or Service Center, call:

USA: 1-888-99-FLUKE (1-888-993-5853)  
 Canada: 1-800-36-FLUKE (1-800-363-5853)  
 Europe: +31 402-678-200  
 Japan: +81-3-3434-0181  
 Singapore: +65-738-5655  
 Anywhere in the world: +1-425-446-5500

Address correspondence to:

Fluke Corporation  
 P.O. Box 9090,  
 Everett, WA 98206-9090  
 USA

Fluke Europe B.V.  
 P.O. Box 1186,  
 5602 BD Eindhoven  
 The Netherlands

Visit us on the World Wide Web at: [www.fluke.com](http://www.fluke.com)

## Precautions and Safety Information

### ⚠ Warning

**If this product is used in a manner not specified by the manufacturer, the protection provided by the equipment may be impaired.**











Read the “Safety Information” page before servicing this product.

In this manual, a **Warning** identifies conditions and actions that pose hazard(s) to the user; a **Caution** identifies conditions and actions that may damage the Meter or the test instruments.

### International Symbols

International symbols used on the Meter and in this manual are explained in Table 1.

**Table 1. International Symbols**

	Risk of electric shock		Earth
	See manual		Fuse
	Equipment protected by double or reinforced insulation		AC or DC
	Battery		Recycling information
	Conforms to CSA C22.2 No 1010.1-92 + Amendment 2 1997, UL 3111 and ANSI/ISA SP82.01 1994	VDE	Conforms to VDE EN61010 (Pending)
	Conforms to EU directives		Conforms to UL 3111.1
CAT III	OVERVOLTAGE (Installation) CATEGORY III, Pollution Degree 2 per IEC1010-1 refers to the level of Impulse Withstand Voltage protection provided. Equipment of OVERVOLTAGE CATEGORY III is equipment in fixed installations (e.g., electricity meter and primary over-current protection equipment).		

**⚠ Safety Information**

**Use of instrument in a manner not specified by the manufacturer may impair safety features/protection provided by the equipment.**

**Read the following safety information carefully before using or servicing the instrument.**

**To avoid electric shock or fire, do the following:**

- **Avoid working alone.**
- **Inspect the test leads for damaged insulation or exposed metal. Check test lead continuity. Damaged leads must be replaced. Do not use the Meter if it looks damaged.**
- **Be careful when working above 30 V ac rms, 42 V ac peak and 60 V dc. Such voltages pose a shock hazard.**
- **When using the probes, keep your fingers away from probe contacts. Keep your fingers behind the finger guards on the probes.**
- **Measurements can be adversely affected by impedances of additional operating circuits connected in parallel or by transient currents.**
- **Verify operation prior to measuring hazardous voltages (voltages above 30 V ac rms, 42 V ac peak and 60 V dc).**
- **Place test leads in proper input terminals.**
- **Disconnect the live test lead before disconnecting the neutral test lead.**
- **Do not use the Meter if the battery indicator (  ) shows a battery empty condition.**
- **Use only Fluke recommended batteries and fuse.**
- **Do not use the Meter with any parts or cover removed.**
- **Do not use the Meter around explosive gas, vapor or dust.**
- **Disconnect the test leads from power sources and from the Meter before changing the batteries or fuse.**
- **Do not use the Meter in a wet environment.**
- **Use only Fluke specified test leads.**

## Specifications

<b>Environmental</b>	
Operating Temperature	-10 °C to +50 °C
Storage Temperature	-40 °C to +70 °C
Temperature Coefficient	0.10 x (specified accuracy)/ °C ( < 18 °C or > 28 °C)
Relative Humidity: Non condensing (< 10 °C) 90 % RH (10 °C to 30 °C) 75 % RH (30 °C to 40 °C) 45 % RH (40 °C to 50 °C)(Without Condensation)	
Dust/water resistance	IP42 per IEC 529
Operating Altitude	2000 m
Storage Altitude	12000 m
<b>Mechanical Specifications</b>	
Size	23,4 x 10 x 6,4 cm (9.2 x 3.9 x 2.5 in)
Weight	1 kg (2.2 lbs.)
Drop requirement	Per IEC 1010-1
Shock and Vibration	Conforms to MIL-PREF-28800F class 3 & 4
<b>Safety Specifications</b>	
Electrical Safety	Meets all requirements of EN61010-1, 1995 and EN61557, 1997
Maximum Operating Voltage	600 V ac or dc between any terminal and earth ground
Protection Levels	CAT III, 600 V, Pollution Degree 2 per EN61010-1
<b>Electromagnetic Compatibility (EMC)</b>	
Immunity & Emmissions	EN 61326-1 (Unspecified for Field strength in excess of 2V/m)
ESD	EN61000-4-2 Satisfies Criteria B
<b>Electrical Specifications</b>	
Battery	C Size 1.5 V alkaline, ANSI/NEDA-14A, IEC-LR14 (4 pieces)
Fuse	6 mm x 32 mm (0.25 x 1.25 inch), 0.5 A 660 V, Fast Acting, 50 A Minimum Interrupt rating

<b>Insulation Resistance</b>	
Display Ranges	4.000 M $\Omega$ , 40.00 M $\Omega$ , 400.0 M $\Omega$ , 4000 M $\Omega$
Measurement Range (per EN61557-2)	0.250 M $\Omega$ to 4000 M $\Omega$
Resolution	0.001 M $\Omega$ to 10 M $\Omega$
Accuracy	2 % + 2 counts 0.250 M $\Omega$ to 100.0 M $\Omega$
	10 % + 2 counts + 1 %/1000 M $\Omega$ 100.0 M $\Omega$ to 4000 M $\Omega$
Analog Bar Graph	0 to $\infty$
Test Voltages	250 V, 500 V, 1000 V
Accuracy	+20 %, -0 %
Nominal Current	1 mA
Number of measurements	5,000
Circuitry Protection	test inhibited if $\geq 30$ V ac or dc at inputs
<b>Lo <math>\Omega</math></b>	
Display Range	40.00 $\Omega$
Measurement Range	0.10 $\Omega$ to 40.00 $\Omega$
Accuracy	2 % + 2 counts
Resolution	0.01 $\Omega$
Analog Bar Graph	0 to 100 $\Omega$
Open Circuit Voltage	6 V typical
Short Circuit Current	200 mA minimum, (0.2 to 2.0 $\Omega$ for >20% battery capacity remaining).
Test Leads Zero	2 $\Omega$
Number of measurements	5,000
Circuitry Protection	test inhibited if $\geq 30$ V ac or dc at inputs
<b>Voltage</b>	
Range	600 V, dc, 50/60 Hz
Resolution	1 V
Accuracy	2 % + 2 counts
Analog Bar Graph	0 to 1000 V
<b>Resistance</b>	
Range	4000 $\Omega$
Accuracy	2 % + 2 counts
Resolution	1 $\Omega$
Analog Bar Graph	0 to 10 k $\Omega$
Beeper	On at $\approx 30$ $\Omega$ or less

## Required Equipment

Required equipment is listed in Table 2. If the recommended models are not available, equipment with equivalent specifications may be used.

Repairs or servicing should be performed only by qualified personnel.

### Caution

**Do not attempt to use the 5500A or other standard calibrator for insulation and continuity resistance tests. Calibrator damage will result.**

Table 2. Required Equipment

Equipment	Minimum Required Characteristics	Recommended Model
Calibrator	AC Voltage Range: 0-600 Vac Accuracy: $\pm 0.5\%$ Frequency Range: DC – 60 Hz Accuracy: $\pm 3\%$  DC Voltage Range: 0-600 Vdc Accuracy: $\pm 0.5\%$  Ohms Range: 0 $\Omega$ - 4000 $\Omega$ Accuracy: $\pm 0.5\%$  Insulation Resistance: 250 k $\Omega$ , 500 k $\Omega$ , 1 M $\Omega$ , 80 M $\Omega$ Accuracy: $\pm 0.5\%$  Continuity Resistance: 2 Ohms, 20 Ohms Accuracy: $\pm 0.5\%$	9100 w/135 option
HV Divider	DC Voltage Range: 1 kV – 5 kV  Accuracy: $\pm 1\%$ Division Ratio: 1000:1 Input resistance: 1000 M $\Omega$	Fluke 80K-40
DMM	DC Voltage Range: 1 – 1000 Vdc Accuracy: $\pm 0.25\%$	Fluke 87-3

## Performance Test

### ⚠ Warning

While performing the following procedures, there are potentially dangerous voltages at the Meter output terminals when the Meter is in the  $M\Omega$  function.

The following performance tests will ensure that the meter is in proper operating condition and meets the published accuracy specifications. If the Meter fails any of the performance test steps, repair is needed.

To perform the tests you will need equipment meeting the minimum specification given in Table 2.

### Display Test

While turning the Meter on, push and hold down the beeper button. Compare the display with the example in Figure 1. Check all segments for clarity and contrast.

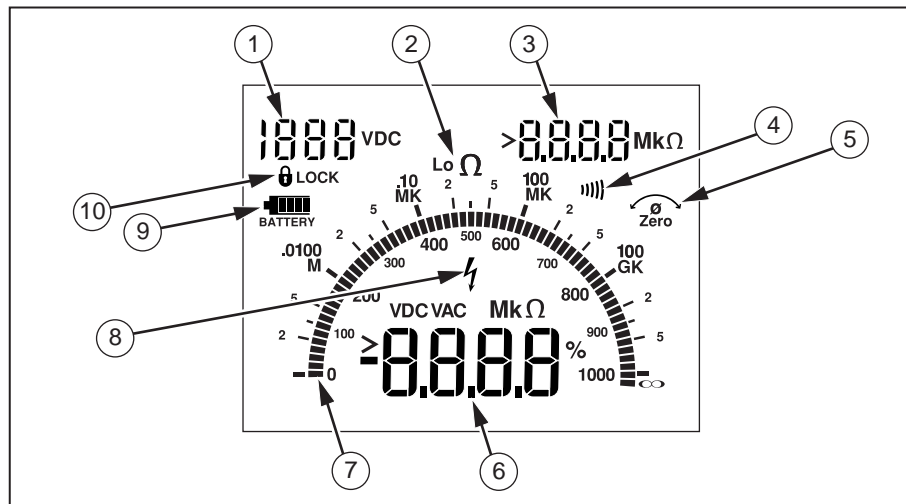

Figure 1. Display

acf12f.eps

Table 3. Display Icons

①	Voltage applied to the probes in Insulation Resistance function.
②	Low Resistance/Resistance function indicator.
③	Resistance reading held from the last measurement in Insulation Resistance or Low Resistance function.
④	Beeper symbol shows if beeper function is turned on in Resistance function.
⑤	Zero symbol is on if test leads are zeroed out.
⑥	Main reading display for all functions.
⑦	Analog bar graph displays resistance on a logarithmic scale and voltage on a linear scale. The value always tracks the main reading.
⑧	High voltage warning symbol flashes if voltage $\geq 30$ V ac or dc is present on the probes.
⑨	Battery life indicator. Displays briefly when the Meter is first switched to a function. Displays the amount of battery voltage left in increments of 25 %.
⑩	Lock symbol is on if the TEST mode is locked in Insulation or Low Resistance functions.

### Backlight Test

Push the backlight button and note that the all three backlight LEDs come on. Each LED can be seen on the left side of the display as an intensified area.

### Battery Test

Turn the Rotary Switch to the Battery Check position and note that the batteries have 90% or better charge. Replace if necessary. Refer to "User Maintenance" for detailed instructions on changing the batteries.

### Discharge Circuit Test

The following Discharge Circuit Test is a safety related test that verifies input jack wiring to the PCA, the RSOB contacts, RSOB pads on the PCA, and other active components on the PCA.

#### Caution

**DO NOT push the Meter TEST button during the following procedure.**

1. Connect the DMM to the V $\Omega$  and COM jack of the Meter.
2. Set the DMM to k $\Omega$  function.
3. Turn the Meter Rotary Switch to the 250V, 500V, 1000V and Lo  $\Omega$  position. Check that the DMM reading for each position is between 1600 and 2600  $\Omega$ .

### Volts and Ohms Measurement Accuracy Verification

To verify accuracy of the V and  $\Omega$  function, complete the following:

Perform the battery test and replace as necessary

1. Connect the Calibrator to the V $\Omega$  and COM inputs on the Meter.
2. Turn the Meter Rotary Switch to the function listed for each step of Table 4.
3. Apply the input for the steps 1 through 10 as listed in Table 4.
4. Compare the Meter displayed reading with the display limits of Table 4.
5. DISCONNECT THE CALIBRATOR FROM THE METER.

**Table 4. Volts and Ohms Test**

Step	Function	Source Output	Display Reading	
			Lower Limit	Upper Limit
1	Volts	0 Volts	-2	2
2	Volts	180 V	174	186
3	Volts	540 V	527	553
4	Volts	180 V @ 60 Hz	174	186
5	Volts	540 V @ 60 Hz	527	553
6	$\Omega$	0 $\Omega$	0	2
7	$\Omega$	1200 $\Omega$ (UTTi High)	1174	1226
8	$\Omega$	3600 $\Omega$ (UTTi High)	3526	3674
9	$\Omega$	Open	>4000	>4000
10	Continuity on	27 $\Omega$	Beeper on	Beeper on



**LO Ohms Measurement Accuracy Verification**

**Caution**

**During the following tests, the 9100 source output must be applied to the UUT prior to pushing the UUT TEST button. Failure to do this WILL damage the 9100.**

**Do not attempt to use the 5500A or other standard calibrator for the following test. Calibrator Damage will result.**

Use the calibrator continuity resistance function to verify accuracy of the LO  $\Omega$  function as follows:

1. Turn the Meter Rotary Switch to LO  $\Omega$ .
2. Connect the calibrator to the Meter  $V\Omega$  and COM input terminals using 4 wire test leads.
3. Apply zero ohms from the calibrator.
4. Zero the LO ohms function (press and release the **TEST** button and then press and hold the **ZERO** button until the Meter beeps).
5. Apply the Calibrator Output values listed in Table 5 and compare the Meter reading with the display reading limits given.

**Table 5. Lo Ohms Test**

Step	Function	Calibrator Output	Display Reading Limits	
			Lower Limit	Upper Limit
1	LO Ohms	2 Ohms	1.94	2.06
2	LO Ohms	20 Ohms	19.58	20.42

**Meg Ohm Measurement Accuracy Verification**

Use the calibrator Insulation Resistance function to verify M $\Omega$  measurement accuracy as follows:

**Caution**

**During the following tests the 9100 source output must be applied to the UUT prior to pushing the UUT TEST button. Failure to do this WILL damage the 9100.**

**Do not attempt to use the 5500A or other standard calibrator for the following test. Calibrator Damage will result.**

**⚠Warning**

**Pushing the TEST button produces a potentially dangerous voltage, at the Meter output terminals, when the Meter is in the MΩ function.**

1. Turn the Meter Rotary Switch to the MΩ function and set the Meter range as listed in Table 6.
2. Apply the calibrator output values listed in step 1 of Table 6.
3. Press and hold the Meter **TEST** button until the Meter display reading settles to its final value.
4. Compare the Meter displayed reading with the display reading limits of Table 6.
5. Release the **TEST** button.
6. Repeat the above process for all remaining steps in Table 6.

**Table 6. Meg Ohm Test**

Step	Function	Range	Calibrator Output	Display Reading	
				Lower Limit	Upper Limit
1	MΩ	250 V	250 kΩ	243	257
2	MΩ	500 V	250 kΩ	243	257
3	MΩ	1000 V	250 kΩ	243	257
4	MΩ	250 V	500 kΩ	488	512
5	MΩ	500 V	500 kΩ	488	512
6	MΩ	1000 V	500 kΩ	488	512
7	MΩ	250 V	1 MΩ	0.978	1.022
8	MΩ	500 V	1 MΩ	0.978	1.022
9	MΩ	1000 V	1 MΩ	0.978	1.022
10	MΩ	250 V	80 MΩ	78.2	81.8
11	MΩ	500 V	80 MΩ	78.2	81.8
12	MΩ	1000 V	80 MΩ	78.2	81.8
13	MΩ	250 V	Open	>1000	>1000
14	MΩ	500 V	Open	>2000	>2000
15	MΩ	1000 V	Open	>4000	>4000

### **Meg Ohm Voltage Source Accuracy Verification**

To verify MΩ Voltage Source Accuracy complete the following procedure:

#### **⚠ Warning**

**Pushing the TEST button produces a potentially dangerous voltage, at the Meter output terminals, when the Meter is in the MΩ function.**

1. Connect the DMM, listed in Table 2, to the Meter VΩ and COM input terminals. Set the DMM to the VDC function.
2. Turn the Meter Rotary Switch to the MΩ function and range listed in Table 7, step 1.
3. Press and hold the **TEST** button until the Meter reading settles to its final value.
4. Compare the DMM reading with the display reading limits of Table 7.
5. Release the **TEST** button.
6. Repeat the above process for Table 7, Step 2.
7. Disconnect the DMM from the Meter and connect the HV Divider to the DMM.
8. Connect the DMM, with HV Divider, to the Meter VΩ and COM input terminals.
9. Press and hold the **TEST** button until the Meter reading settles to its final value.
10. Compare the DMM display reading with the display reading limits of Table 7, step 3.

**Table 7. Meg Ohm Voltage Source Test**

Step	Function	Range	Measurement Device	Display Reading	
				Lower Limit	Upper Limit
1	MΩ	250 V	Test DMM	250	300
2	MΩ	500 V	Test DMM	500	600
3	MΩ	1000 V	Test DMM with HV Divider	1.000	1.200

## Maintaining the Meter

This section provides basic maintenance information, including fuse and battery replacement instructions.

### Caution

**Do not attempt to repair or service your Meter unless you are qualified to do so and have the relevant calibration, performance test, and service information.**

### Cleaning

Clean only with soap and water. Remove any residue afterwards.  
Periodically wipe the case with a damp cloth and mild detergent.  
Do not use abrasives or solvents.

### Replacing and Disposing of the Batteries

#### Warning

**To avoid electric shock, disconnect the test leads from the inputs before opening the Meter for battery replacement.**

**To avoid false readings, which could lead to possible electric shock or personal injury, replace the batteries as soon as the battery empty indicator  appears.**



*This Meter contains alkaline batteries. Do not dispose of these batteries with other solid waste. Used batteries should be disposed of by a qualified recycler or hazardous materials handler. Contact your authorized Fluke Service center for recycling information.*

The Meter uses four alkaline C cell batteries (supplied). To replace the batteries, do the following (see Figure 2):

1. Turn the rotary switch to the OFF position.
2. Disconnect test leads from any power source.
3. Remove the holster.
4. Place the Meter face down on a nonabrasive surface and loosen the two screws with a flat-blade screwdriver.
5. Lift the battery access lid away from the Meter.
6. Replace the C cells as shown in Figure 2. Observe the battery polarity shown in the battery compartment.
7. Secure the battery access lid back in position with the two screws.

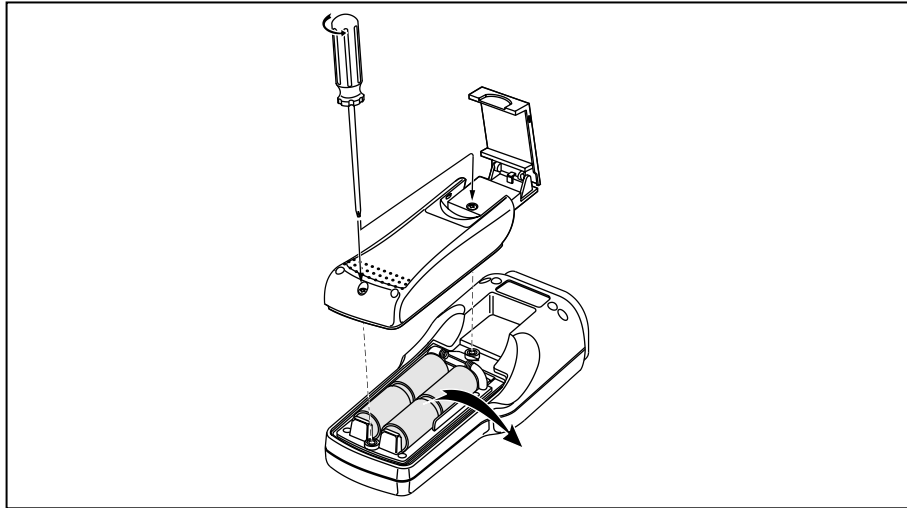

Figure 2. Replacing the Batteries

acf10f.eps

### **Testing and Replacing the Fuse**

#### **⚠ Warning**

To avoid electric shock, disconnect the test leads from the inputs before opening the Meter for fuse replacement.

To prevent personal injury or damage to the Meter, install **ONLY** the Fluke specified fuse identified in the “Replacement Parts and Optional Accessories” section.

Before replacing the fuse, test it as described in the next section.

#### **Testing the Fuse**

Use the following procedure to test the internal fuse of the Meter.

1. Turn the rotary switch to the Lo  $\Omega$  Function.
2. Connect the test leads to the input terminals and short them together. Press **TEST**.
3. The display should indicate approximately 0.5  $\Omega$ . If the display reads **>40  $\Omega$** , replace the fuse as described next and test again.

## Replacing the Fuse

### **⚠ Warning**

**To avoid electric shock, personal injury or damage to the Meter, use ONLY the specified fuse, and in accordance with the following procedure.**

If the previous fuse test indicates that the fuse is defective (resistance > 40  $\Omega$ ), replace the fuse as follows:

1. Turn the rotary switch to the OFF position.
2. Disconnect test leads from any power source.
3. Follow Steps 3 - 5 to remove the battery access lid as described under "Replacing and Disposing of the Batteries".
4. Unscrew the bottom cover as shown in Figure 3.
5. Remove the fuse as shown in Figure 3.
6. Replace with a new fuse.
7. Place the bottom cover on and secure the screws.
8. Insert the batteries. Observe the battery polarity shown in the battery compartment.
9. Secure the battery access lid.
10. Test the fuse as described under "Testing the Fuse".

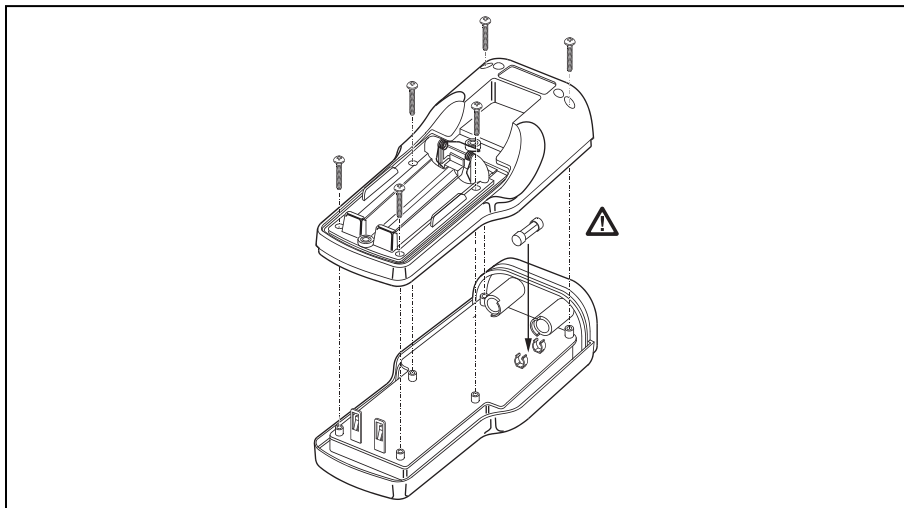

**Figure 3. Replacing the Fuse**

acf11f.eps

## Replacement Parts and Optional Accessories

Replacement Part	Part Number
Battery 1.5 V Alkaline Size C	423582
Test Lead set	669058
Test Probe, 1 kV, lantern tip, red	803459
Test Probe, 1 kV, lantern tip, black	803467
Alligator Clip, red	803434
Alligator Clip, black	803442
Carrying Case	603115
Holster	670643
Hand Strap	669069
Fuse,0.5A,750VAC,Fast Acting,0.25X1.25,Glass Tube	1556096
Battery Spring	936906
Screw	942946
Shock Absorber	948708
Battery Cover (Overmolded)	1274679
Hook, (Pad Transfer)	1270801
User Manual, Multi-Language	1543203
CD Rom (containing Fluke Users Manual)	1558934
Optional Accessories	Part Number
Harness	669074
Tool Pack	669903

